

**SM4M/SM16M STORAGE MODULE
INSTRUCTION MANUAL**

REVISION: 03/00

COPYRIGHT (c) 2000 CAMPBELL SCIENTIFIC, INC.

WARRANTY AND ASSISTANCE

The **SM4M/SM16M STORAGE MODULE** is warranted by CAMPBELL SCIENTIFIC (CANADA) CORP. ("CSC") to be free from defects in materials and workmanship under normal use and service for **thirty-six (36) months** from date of shipment unless specified otherwise. ***** **Batteries are not warranted** ***** CSC's obligation under this warranty is limited to repairing or replacing (at CSC's option) defective products. The customer shall assume all costs of removing, reinstalling, and shipping defective products to CSC. CSC will return such products by surface carrier prepaid. This warranty shall not apply to any CSC products which have been subjected to modification, misuse, neglect, accidents of nature, or shipping damage. This warranty is in lieu of all other warranties, expressed or implied, including warranties of merchantability or fitness for a particular purpose. CSC is not liable for special, indirect, incidental, or consequential damages.

Products may not be returned without prior authorization. To obtain a Return Merchandise Authorization (RMA), contact CAMPBELL SCIENTIFIC (CANADA) CORP., at (780) 454-2505. An RMA number will be issued in order to facilitate Repair Personnel in identifying an instrument upon arrival. Please write this number clearly on the outside of the shipping container. Include description of symptoms and all pertinent details.

CAMPBELL SCIENTIFIC (CANADA) CORP. does not accept collect calls.

Non-warranty products returned for repair should be accompanied by a purchase order to cover repair costs.



campbell scientific (canada) corp.

11564 149 st • edmonton • alberta • T5M 1W7 • (780) 454 2505 • fax (780) 454 2655

SM4M/16M Storage Module

Table of Contents

Section 1. SM4M/SM16M Storage Module Overview. 1-1

| | |
|--|-----|
| 1.1 Specifications..... | 1-1 |
| 1.2 Physical Description | 1-2 |
| 1.3 Power | 1-3 |
| 1.3.1 Primary Power | 1-3 |
| 1.3.2 Backup Power and Data Retention | 1-3 |
| 1.4 Function..... | 1-3 |
| 1.4.1 Operating with Current Dataloggers | 1-3 |
| 1.4.2 Operation with Dataloggers with Older Operating Systems | 1-4 |
| 1.4.3 Data Retrieval/Telecommunication Command State | 1-4 |
| 1.4.4 Memory Configuration | 1-5 |
| 1.4.5 Baud Rates | 1-5 |
| 1.4.6 File Marks | 1-5 |
| 1.4.7 Power-up Status Indication | 1-6 |
| 1.5 Quick Start-Up Procedure..... | 1-6 |
| 1.5.1 Preparation | 1-7 |
| 1.5.2 Programming the Datalogger to Send Data to the Storage Module | 1-7 |
| 1.5.3 Manual Dump | 1-7 |
| 1.5.4 Data Retrieval | 1-7 |

Section 2. Storing Data from Current Dataloggers ... 2-1

| | |
|---|-----|
| 2.1 Instruction 96—Output Data Under Program Control..... | 2-1 |
| 2.1.1 Multiple Storage Modules with the CR500/510, CR10/10X, or CR23X..... | 2-2 |
| 2.1.2 Use of Two Storage Modules with the 21X or CR7 | 2-3 |
| 2.2 *8 and *9 Mode—Keyboard-Initiated Data Transfer | 2-3 |
| 2.2.1 *8 Mode—CR500/510, CR23X, CR10/10X..... | 2-3 |
| 2.2.2 *9 Mode—21X or CR7..... | 2-3 |
| 2.3 Storing Burst Measurement Data from the CR10/10X, CR23X, or 21X..... | 2-4 |
| 2.3.1 Burst Data with CR10/10X, CR23X Dataloggers..... | 2-4 |
| 2.3.2 Burst Data with 21X Dataloggers | 2-4 |

Section 3. The Printer Enable Method of Data Storage 3-1

| | |
|--|-----|
| 3.1 Baud Rates | 3-1 |
| 3.2 Storing Data from the 21X and CR7..... | 3-1 |
| 3.2.1 Instruction 96—Output Under Program Control..... | 3-1 |
| 3.2.2 *4 Mode—Output Device Enable | 3-2 |
| 3.2.3 *9 Mode—Keyboard-Initiated Data Transfer | 3-2 |
| 3.3 Special Data Storage Operations | 3-2 |
| 3.3.1 DSP4 Heads Up Display | 3-2 |
| 3.3.2 Storing Burst Measurement Data from the 21X..... | 3-2 |

| | |
|---|------------|
| Section 4. Storage Module Memory: Details of Data Storage..... | 4-1 |
| 4.1 File Marks..... | 4-1 |
| 4.2 Pointers..... | 4-1 |
| 4.3 Data Formats — Space Requirements..... | 4-2 |
| 4.4 Available Storage..... | 4-2 |
| 4.5 Bad Data..... | 4-3 |
| Section 5. Data Retrieval..... | 5-1 |
| 5.1 Hardware..... | 5-1 |
| 5.1.1 SC532..... | 5-1 |
| 5.1.2 Via Datalogger..... | 5-2 |
| 5.2 SMS..... | 5-3 |
| 5.3 Without SMS..... | 5-3 |
| 5.3.1 Direct Connection..... | 5-3 |
| 5.3.2 Connection Via CR500/510, CR10/10X or CR23X..... | 5-3 |
| Section 6. Storing and Retrieving Datalogger Programs..... | 6-1 |
| 6.1 SMS Storage Module Support Software..... | 6-1 |
| 6.2 *D Mode—with Datalogger..... | 6-1 |
| 6.3 Using DSP4 Heads Up Display to Store and Retrieve Datalogger Programs..... | 6-2 |
| Appendix A. *9 Mode—Storage Module Commands..... | A-1 |
| Appendix B. Telecommunications Commands..... | B-1 |
| Appendix C. Storage Module 9-Pin Connector..... | C-1 |
| Appendix D. Upgrading the Operating System..... | D-1 |

Figures

| | |
|--|-----|
| 1-1 Storage Module and SC12 Cable..... | 1-2 |
| 1-2 Operation with Current Dataloggers..... | 1-4 |
| 1-3 Pin-Enable Operations..... | 1-4 |
| 1-4 Telecommunications Command State | 1-5 |
| 5-1 Storage Module Connected to a Portable PC via an SC532 Interface.. | 5-1 |
| 5-2 Communication Via the CR500/510, CR10/10X or CR23X..... | 5-2 |
| 5-3 Communication Via the CR23X..... | 5-2 |

Tables

| | |
|---|-----|
| 4-1 Ring-Memory Effective Memory Capacity | 4-3 |
| 6-1 *D Mode Keyboard Commands..... | 6-1 |
| A-1 *9 Mode Commands for Storage Module..... | A-2 |

Section 1. SM4M / SM16M Storage Module Overview

Campbell Scientific's SM4M and SM16M storage modules expand on-site data storage for users of Campbell Scientific dataloggers. They also provide the user with a convenient method of transporting data from the field back to the office. The SM4M and SM16M are compatible with the CR500/510, CR10/10X, 21X, CR23X and CR7 dataloggers as well as the DSP4 Heads Up Display.

This manual contains two broad divisions. The Overview surveys the storage modules and their function. It also explains how to quickly begin using a storage module for straightforward data storage operations. The remainder of the manual is a technical reference which describes in detail such operations as: storing data from current dataloggers, storing data from older dataloggers, data retrieval, and datalogger program storage and retrieval.

The Overview should be read by all users, as should Section 5 (Data Retrieval). Users with the CR500/510, CR10/10X, CR23X or with the 21X or CR7 with recent operating systems (i.e., current dataloggers) should read Section 2, while users of Campbell Scientific's older dataloggers should read Section 3. Section 6 (Storing and Retrieving Datalogger Programs) and Appendix B (Telecommunication Commands) may be used as needed.

SMS (storage module software) simplifies communication procedures between dataloggers and storage modules. SMS is part of Campbell Scientific's PC208W Windows-based datalogger support software. Contact Campbell Scientific for further information.

1.1 Specifications

| | |
|------------------------------|---|
| Storage Capacity: | |
| SM4M: | 2 Million low-resolution data values |
| SM16M: | 8 Million low-resolution data values |
| Program storage: | stores to eight programs with a total capacity of 128 kbytes (including labels) |
| Dimensions: | 135 x 75 x 20 mm |
| Weight: | 200 g |
| Canister: | Sealed |
| Processor: | Hitachi H8S |
| Operating system: | 64 kbytes, flash memory based, user downloadable. |
| Operating Temp. Range: | -35°C to +65°C (-55°C to +85°C optional) |
| Baud Rates for data storage: | 9600, 76800 baud |

| | |
|--|---|
| Baud Rates for telecommunications: | 300, 1200, 2400, 4800, 9600, 19200, 38400, 57600, 76800, 115200. |
| Memory Configuration: | User selectable for either ring style (default) or fill and stop. |
| Power Requirements: | 5 ±0.3V DC @ 100mA (max.) |
| Current drain: | |
| Active, processing, (e.g., memory test): | 30–40 mA (avg.) |
| Active, but waiting, (e.g., communications mode): | 10mA (avg.) |
| Typical current during data storage from a datalogger: | 15 mA (avg.) |
| Low Power Standby State: | less than 200µA. |
| Peak current (flash erase): | 60 mA |
| Maintenance: | There are no user-serviceable parts inside the storage module. |

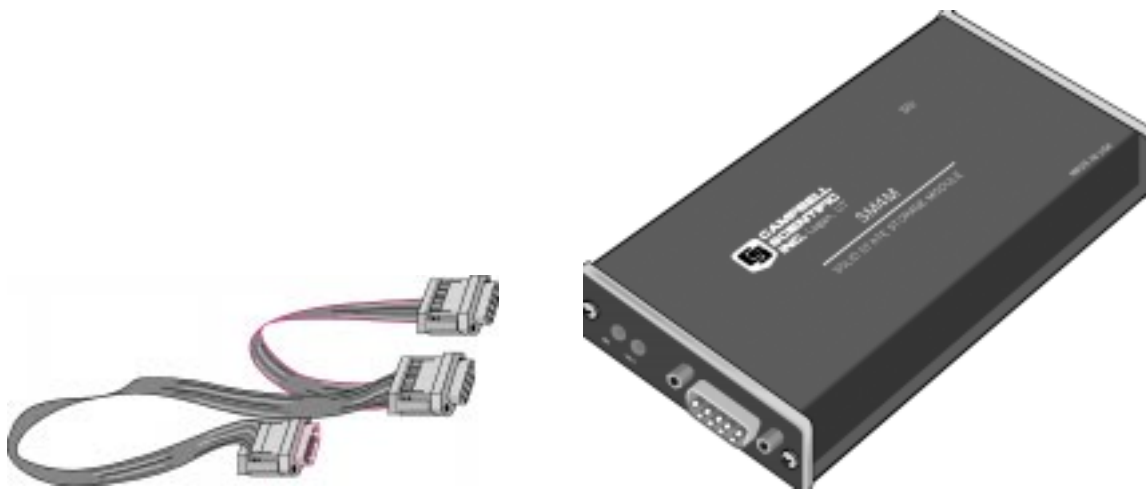

FIGURE 1-1. Storage Module and SC12 Cable

1.2 Physical Description

The storage module is housed in a sealed canister with a single, 9-pin D-connector. The storage module is connected to a datalogger via the SC12 9-conductor ribbon cable.

There are two LEDs (light emitting diodes) adjacent to the connector. A red, status LED indicates the operational status of the module at power-up (see section 1.4.7) and a green LED lights when data are being stored in the module.

The SM4M and SM16M are identical except for the amount of memory they contain. The internal memory is split into 64 kbyte blocks. There are 64 blocks of memory in an SM4M and 256 blocks in an SM16M. This equates to a capacity of more than 2 million low-resolution storage values for the SM4M and more than 8 million low-resolution values for the SM16M (Section 4.4).

1.3 Power

1.3.1 Primary Power

The storage module is powered by 5 VDC received from the datalogger or from data retrieval interfaces such as the SC532 9-pin Peripheral to RS232. Pin 1 of the 9-pin D-connector supplies the 5 VDC. Pin 2 is both the power ground and signal ground.

1.3.2 Backup Power and Data Retention

The modules use non-volatile flash EEPROM memory which does not require power to retain data. There is no internal battery.

The flash memory will retain stored data for approximately 10 years. Typically, the flash memory can be erased and rewritten a minimum of 100,000 times.

1.4 Function

The SM4M and SM16M storage modules supplement the storage capacity in a datalogger. The storage modules can store data from Campbell Scientific dataloggers and from other devices which properly enable them.

All storage module operations occur in one of three basic operational modes:

1. Interactive communication with the datalogger for data and program storage and retrieval.
2. The Printer-Enable Method for data storage with the 21X and CR7, with older operating systems, and also with the DSP4.
3. The Telecommunications Command State for data retrieval and other miscellaneous operations.

1.4.1 Operation with Current Dataloggers

The storage module uses an interactive command structure with handshaking when connected to the CR500/510, the CR10/10X, CR23X, or to the 21X or CR7 fitted with recent software (see Figure 1-2). If the storage module is not connected the datalogger does not send data. The datalogger detects when the storage module is connected and sends the backlogged data the next time it executes Instruction 96.

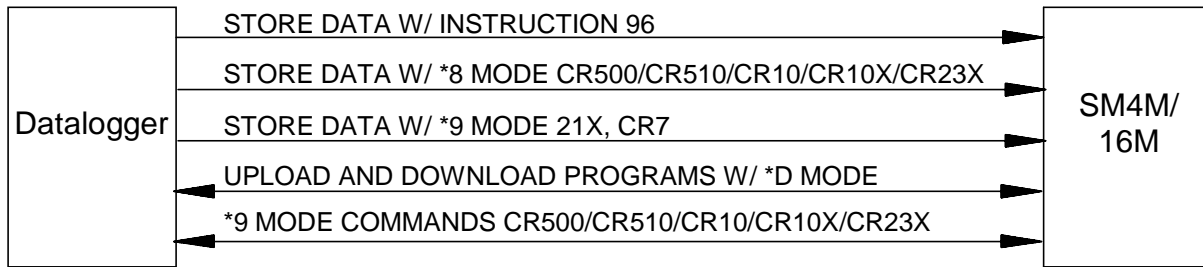

FIGURE 1-2. Operation with Current Dataloggers

The storage module can store data either under program control (Instruction 96) or under user control (*8 Mode with CR500/510/10/10X/23X, *9 Mode with 21X and CR7). Datalogger programs can be stored in and retrieved from the storage module using the *D Mode. The CR500/510/10/10X/23X *9 Mode enables the user to directly execute commands such as: change address, view data, etc. (see your datalogger manual for full details).

1.4.2 Operation with Dataloggers with Older Operating Systems (Printer-Enable Method)

In the Printer-Enable Method (see Figure 1-3), the storage module stores all data received (on pin 9) while the printer enable line (pin 6) is high. The storage module automatically detects the baud rate from the sending device (9600 or 76800 only). The datalogger cannot detect if the storage module is connected. Data are sent whether or not the storage module is connected.

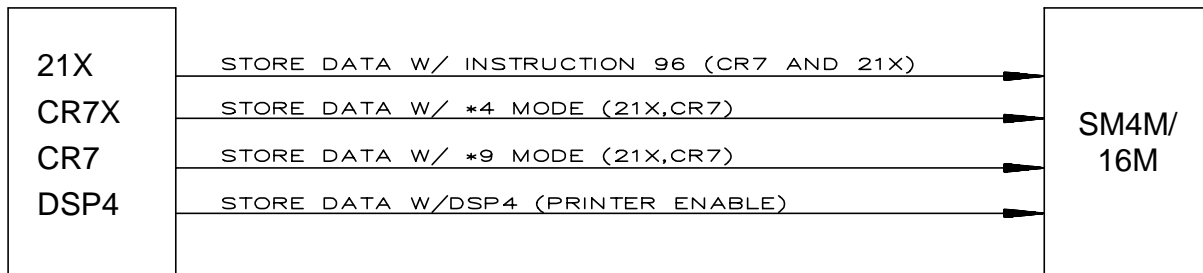

FIGURE 1-3. Pin-Enable Operations

Data can be stored in the storage module under program control (Instruction 96 or *4 Mode) or under user control (*9 Mode). Operations with the DSP4 Heads Up Displays also use the Printer-Enable Method (see Section 3).

1.4.3 Data Retrieval / Telecommunication Command State

Data retrieval and other interactive operations with a computer take place in the Telecommunications command state (see Figure 1-4). PC208W uses the Telecommunications Commands for data retrieval. Direct telecommunication commands can also be sent from SMS (part of PC208W) in the Terminal Emulator mode. A list of direct telecommunication commands is shown in Appendix B.

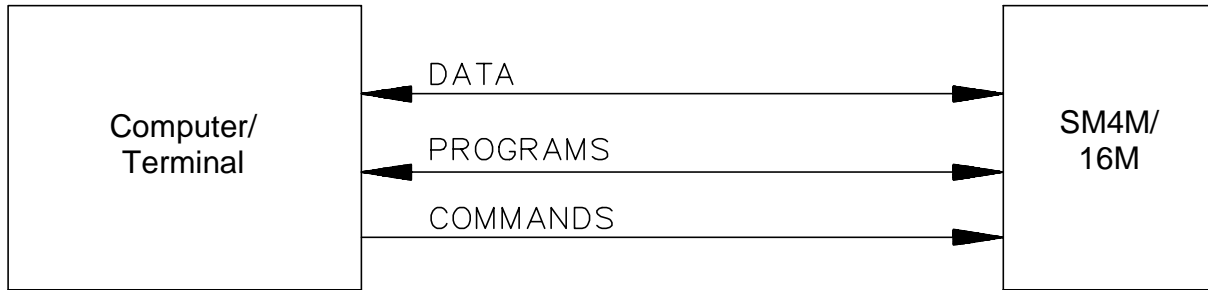

FIGURE 1-4. Telecommunications Command State

1.4.4 Memory Configuration

The storage module's memory can be configured as either Fill and Stop or Ring memory. In the Fill and Stop configuration, the storage module stops accepting data when its memory is full. No data write-over occurs with this configuration. In the Ring Memory configuration (the default setting), new data continues to be stored even after the memory is full. Once full, new data are written over the oldest data. The storage module's memory configuration can be changed using SMS or with command 4 of the CR500/510, CR10/10X, CR23X *9 Mode.

1.4.5 Baud Rates

The storage module automatically detects the baud rate of data sent to it.

When using the telecommunications commands, sending several carriage returns will cause the storage module to match the computer's baud rate (see specifications above).

1.4.6 File Marks

File Marks are used to separate data in the storage module. A File Mark is automatically placed in the storage module's memory when the storage module is connected to a power source (datalogger or retrieval interface), when the datalogger compiles a program containing Instruction 96, or under program control. For example, if the user has retrieved data from one datalogger, disconnects the storage module and then connects it to a second datalogger, a File Mark is placed in the data when the second datalogger is connected. This mark follows the data from the first datalogger and precedes the data from the second.

CAUTION

The storage module must be disconnected from power for 10 seconds to be certain it places a File Mark in the storage module when reconnected.

A File Mark can be placed in the data by using SMS or the CR500/510/10/10X/23X *9 Mode command 3. The storage module will not store back-to-back file marks; if a File Mark is the last thing stored in memory, a second file mark will not be stored.

1.4.7 Power-up Status Indication

When power is applied to the storage module by plugging it into a datalogger or SC532, the red “Status” LED will flash to indicate the status of the module.

CAUTION

The storage module must be disconnected from power for a minimum of 10 seconds to ensure it powers down and performs the status check when reconnected.

After connection there will be a short delay when neither LED is illuminated. The length of the delay is variable and is partly determined by the address of the module. This delay avoids excessive power consumption during power-up, when several modules are connected to the datalogger. For a module at address 1 the initial delay will be up to 2 seconds. The delay increases by approximately one second for each increase in the address number.

The first flash after the delay will last from 1 to 2 seconds, depending on the last use of the module. Further flashes follow with a 0.5 second OFF and 0.5 second ON spacing.

The total number of flashes indicates the status of the module, as follows:

| | |
|--|------------|
| Module OK | 1 flash |
| Module operating system corrupted | 2 flashes |
| OK and Program area full | 3 flashes |
| Flash memory corrupted | 4 flashes |
| Storage module overwriting oldest data (ring mode) | 5 flashes |
| Storage module full | 7 flashes |
| Previous operating system load failed | 10 flashes |

If the module is connected to a datalogger which has data to send, the green “Write” LED may start to flash shortly after the end of the Status flash, as the module becomes available to receive data and store it.

The module will only receive data if the status is OK, or OK and program area full. For any of the other status conditions the module will not accept any further data until the fault has been corrected.

1.5 Quick Start-Up Procedure

This Section describes the basics of storing and retrieving datalogger data. These operations are discussed in detail in Sections 3, 4 and 5 of this manual.

1.5.1 Preparation

Before putting the storage module into service, connect it to a computer and use SMS to reset the storage module and test the memory.

If it is not possible to use a PC and SMS, you must establish communication between the storage module, the available computer or terminal (see Section 5), and reset the storage module using the telecommunications commands (see Appendix B) or use the *9 Mode in the CR500/510, CR10/10X or CR23X.

There are two possible reset mechanisms. A full reset and test (command 1248k), which erases the memory and then carries out a thorough test of the storage memory, and the quick reset (command 1249k). While the 1248k command thoroughly checks the module, it can take some time to perform this test (over 20 minutes for larger modules). A quick reset, resets all the memory pointers and erases the flash chips. It also does a less rigorous test of the flash memory, but the test is adequate for most purposes. An SM16M will take around 3 minutes to perform a quick reset.

1.5.2 Programming the Datalogger to Send Data to the Storage Module

Instruction 96 is used in the datalogger program to send data to the storage module. The storage module is connected to the datalogger with the SC12 cable. Each time Instruction 96 is executed, Final Storage data accumulated since the last transfer is sent to the storage module.

For the CR7 and 21X *without* Instruction 96, the *4 Mode can be used to send data to a storage module. The Output Enable code should be set to X1, Printer Enabled ASCII.

The DSP4 outputs data to a storage module when the storage module function (or, for older versions of software, the printer function) is enabled.

1.5.3 Manual Dump

The *8 Mode in the CR500/510/CR10/CR10X/CR23X or the *9 Mode in the 21X and CR7 can be used to transfer data to the storage module under keyboard control (Section 4).

1.5.4 Data Retrieval

The simplest method of retrieving data from the storage module is to use SMS which is part of the PC208W support package. If you have a computer which cannot run this software, the storage module telecommunications commands can be used to retrieve the data. Data retrieval (including interface devices) is discussed in Section 5.

Section 2. Storing Data from Current Dataloggers

This section covers data storage from the CR500/510, CR10/10X, CR23X and from the 21X and CR7 with current software. See Section 3 for the 21X and CR7 with early operating systems.

2.1 Instruction 96 — Output Data Under Program Control

Instruction 96 is used to send Final Storage data to a storage module or to insert a filemark into data under program control. Instruction 96 should be entered into the program table following the Output Processing Instructions. Instruction 96 should be executed each time the table is executed (i.e., the program should not branch around or skip over Instruction 96).

Instruction: 96

Parameter: 01:

7X — CR500/510, CR10/10X, CR23X uses option 7X to send the data to the storage module with address 'X'. X = 1 – 8

30 — 21X and CR7 use option code 30 to send data to the storage module.

When output to the storage module is enabled with Instruction 96, the storage module(s) may either be left on-site and periodically exchanged, or brought to the site to extract the data from the datalogger.

The datalogger is capable of recognizing whether or not the storage module is connected. Each time Instruction 96 is executed and there are data to output, the datalogger checks for the presence of the storage module. If one is not present, no data are sent; the datalogger continues its other operations without advancing its storage module Pointer.

When you finally connect the storage module to the datalogger, two things happen:

1. Immediately on connection, a File Mark is placed in the storage module memory at the position of the Module's Storage Reference Pointer (SRP). The File Mark allows the operator to distinguish blocks of data from different dataloggers or from different visits to the field.
2. During the next execution of Instruction 96, the datalogger recognizes that the storage module is present, outputs all of the data stored since the previous output, and updates the storage module Pointer to the DSP location. This transfer occurs in binary at 9600 baud.

Under optimum conditions, the datalogger outputs 480 low resolution data points per second. For example, a full 128K CR10 takes over two minutes to complete the data transfer. If the execution interval is less than two minutes, the data transfer will be interrupted and will take longer to complete.

CAUTION

Be sure to complete the data transfer *before* making any changes in the datalogger program. Changing a program and then compiling it will advance the datalogger's Storage Module Pointer to the position of the DSP. If this is done before connecting the storage module to allow the datalogger to transfer the data, the old data will *not* be automatically transferred to the storage module. Also, the Instruction 96 data transfer will not take place while the datalogger is in communication with another device (e.g., a computer or an active CR10KD).

To be certain that the storage module has been connected during an execution of Instruction 96, you can observe the green "WRITE" LED of the SM which indicates data are being stored in the module. The user connects the SM to the datalogger waits for the LED to light. *When the LED goes off*, data transfer is complete and the SM can be disconnected.

To avoid data loss, data must be retrieved before the datalogger's ring memory wraps around and begins to write over the oldest data.

2.1.1 Multiple Storage Modules with the CR500/510, CR10/10X, or CR23X

These dataloggers use synchronous addressing to communicate with multiple peripherals. The CR23X must have OS1.7 or later to work with multiple modules. Up to four SM4M/SM16M storage modules can be connected reliably to a single datalogger. Each is assigned an address, 1 to 8. Addresses are assigned in the *9 Mode (command 10), using SMS or in the Telecommunications Command State (the L command). These are discussed in the datalogger manuals and Appendix B respectively. The default storage module address on reset (as sent from the factory) is #1. This will be sufficient for most users.

CAUTION

While eight storage modules can be addressed, communication may be unreliable if more than four SM4M or SM16M modules are connected to a datalogger at a time. Contact Campbell Scientific if you need to connect more than four modules.

At a given time, only one storage module will accept commands directed to SM #1. If there is no storage module with address #1, the storage module with the lowest numbered address will accept the commands sent to SM #1. Commands directed to addresses other than #1 can be accepted *only* by the SM with the correct address. Do *not* connect storage modules with the same address to a datalogger at the same time.

If only one storage module is used with the datalogger, its address should be #1. When multiple storage modules are used in a datalogger system, each should be assigned its own address and set to Fill and Stop. Instruction 96 is used in the datalogger program to send data to storage module address #1. The lowest numbered storage module will fill up first, followed by the next lowest address, and so on. Alternatively, data can be sent to specific storage modules via direct addressing by the datalogger (using a separate Instruction 96 for each SM).

Instruction 96 can be entered two or more times in a program to sort data to specific storage modules. Three important considerations are:

1. All storage modules to be used must be connected to the datalogger with SC12 cables.
2. Time must be allowed between the execution of multiple instances of Instruction 96 to storage modules. Add 5ms to the time it takes to store the number of bytes to be transmitted (1ms per byte) before executing the next Instruction 96 which addresses a different storage module.
3. Use of the keyboard or telecommunications during the execution of the Instruction 96 may backlog the data to be sent to the storage modules. In this event, during the next execution of Instruction 96 all backlogged data will be sent to the storage module addressed in that instruction.

2.1.2 Use of Two Storage Modules with the 21X or CR7

For large volumes of data, two storage modules can be connected to the 21X or CR7. Use SMS to set one SM as Fill and Stop, and the other as Ring Memory.

2.2 *8 and *9 Mode — Keyboard-Initiated Data Transfer

2.2.1 *8 Mode — CR500/510, CR23X, CR10/10X

The *8 Mode is used to manually initiate a Final Storage data transfer from the datalogger to an external peripheral. Data transfer rate is 9600 baud. Refer to the discussion of the *8 Mode in the datalogger Operator's Manual for full details.

2.2.2 *9 Mode — 21X or CR7

The *9 Mode in the 21X and CR7 dataloggers is used to transfer a specified block of data from Final Storage to the storage module. Consult the appropriate datalogger manual for details.

NOTE

This function is different from the *9 Mode in the CR500/510, CR10/10X or CR23X.

2.3 Storing Burst Measurement Data from the CR10/10X, CR23X or 21X

Burst Measurement (Instruction 23) is a special datalogger instruction used to make fast analog voltage measurements. Two options are available for data retrieval with this instruction:

1. Data are stored in the datalogger Input Storage Locations

or

2. Raw data are output from the datalogger serial port.

In option 2, the storage module can capture the data at 76,800 baud. Burst data are output by the datalogger in a unique format which includes calibration measurements at the beginning and end of the series of measurements. Split (part of the PC208/PC208W software packages) will translate this Burst data.

2.3.1 Burst Data with CR10/10X, CR23X Dataloggers

Entering a '3' for the third digit in parameter 4 of Instruction 23 selects the storage module as the destination of the Burst data. All storage modules connected should be set to Fill and Stop and have consecutive addresses. The Burst data will be sent to the first available (lowest addressed) storage module, followed by the next lowest addressed, and so on.

2.3.2 Burst Data with 21X Dataloggers

To send Burst Measurement (Instruction 23) data to the storage module from the 21X, set the Destination option (parameter 4) to 2 for serial port output at 76,800 baud.

Section 3. The Printer Enable Method of Data Storage

Data from the 21X and CR7 with PROMs older than the OSX and OX7 series PROMs (and from the CR21 and DSP4) are stored in the storage module via the Printer Enable Method; i.e., data on the TD line (pin 9) are stored while the PE line (pin 6) is high. The storage module defaults to the Printer Enable Method each time it is powered up by 5V DC applied to pin 1 of its 9-pin 'D' connector. Up to two storage modules can be connected to the 21X or CR7 dataloggers at one time. If two are connected, one should be set to Fill and Stop and the other configured as Ring Memory. Storage module-to-storage module dumps are not possible with the Printer Enable Method.

CAUTION

If the PE line is high when power is applied, the storage module will not store data until the next time PE goes high. Also, if power to the storage module is interrupted during a transmission, data stored since the last time PE went high will be lost.

3.1 Baud Rates

In the Printer Enable Method, you must ensure that the baud rates of the storage module and the datalogger are matched. The SM4M/SM16M will only accept data at 9600 or 76800 baud. There is no user configuration for this setting in the module it automatically detects the speed of the data sent to it.

Baud rate errors (i.e., baud rate mismatches between the datalogger and the storage module) cause the storage module to increment its error counter and enter a low power standby state.

3.2 Storing Data from the 21X and CR7 (All Versions Prior to OSX and OS7 Release)

Instruction 96 is the recommended method for the CR7 and the 21X with Extended Software. The *4 Mode could also be used to transmit data in ASCII format but Instruction 96 is more efficient as data are transferred in the most compact binary format – therefore it is not recommended.

For large volumes of data two storage modules can be connected to the datalogger. Use SMS to set one as Fill and Stop, and the other as Ring Memory.

3.2.1 Instruction 96 — Output Under Program Control

Instruction 96, available in the CR7X and in the Extended Software PROMs for the earlier versions of the 21X, is used to send Final Storage data to the storage module under program control. Instruction 96 should follow the Output Processing Instructions in the program table. Consult the datalogger manual for

details about using Instruction 96. Do *not* use both the *4 Mode and Instruction 96 to activate a device in a datalogger program.

Instruction: 96

Parameter: 01:22

Explanation: Option 22 selects binary printer output at 9600 baud. The left digit specifies the device option and the right, the baud rate. Refer to the datalogger manual for further details.

3.2.2 *4 Mode — Output Device Enable

The *4 Mode is used to enable the output of Final Storage data to a printer. The storage module will capture this printer output.

Select option 'X1' in window 1, and set the baud rate at 9600 (option 02) in window 2 (to match the storage module's default setting). Data are written to the storage module each time data are sent to Final Storage.

CAUTION

While the module will work with *4, data are stored in the module in ASCII format which requires up to 5 times more memory space than binary format. Consider buying an operating system upgrade for dataloggers that do not allow binary data storage with P96.

3.2.3 *9 Mode — Keyboard-Initiated Data Transfer

The *9 Mode in the 21X and CR7 dataloggers is used to transfer a specified block of data from Final Storage to the storage module. Consult the appropriate datalogger manual for details. This function is different from the *9 Mode in the CR10/10X/CR23X.

3.3 Special Data Storage Operations

3.3.1 DSP4 Heads Up Display

In addition to real-time monitoring of datalogger measurements, the DSP4 Heads Up Display can be used with the CR10/10X, CR23X, 21X and CR7 dataloggers to store and retrieve data and programs. With the DSP4 storage module function enabled, datalogger Final Storage data can be sent to the storage module. Refer to the DSP4 Instruction Manual for more details regarding use with Storage modules.

3.3.2 Storing Burst Measurement Data from the 21X

Burst Measurement (Instruction 23) is a special datalogger instruction available for the 21X which makes fast analog voltage measurements. Two options are available for data retrieval with this instruction:

1. Data are stored in datalogger Input Storage locations

or

2. Raw data are sent out the datalogger serial port. In the second case, the storage module can capture data at 76,800 baud.

When the Burst Measurement (Instruction 23) is used with the 21X, select the destination (parameter 4) option as 2 for serial port output at 76,800 baud to send data to the storage module. Burst data are output by the datalogger in a unique format which includes calibration measurements at the beginning and end of the series of measurements. Split (part of PC208/PC208W) will translate Burst data.

Section 4. Storage Module Memory: Details of Data Storage

Detailed knowledge of the way data are stored in the storage module is not normally necessary for day-to-day use. However, if you ever need to work the exact memory available or try to extract corrupted data it may be helpful to know these details.

4.1 File Marks

File Marks are used to separate data in the storage module. A File Mark is automatically placed in the storage module's memory when the storage module is connected to a power source (datalogger or retrieval interface), when the datalogger compiles a program containing Instruction 96, or under program control. For example, if the user has retrieved data from one datalogger, disconnects the storage module and then connects it to a second datalogger, a File Mark is placed in the data when the second datalogger is connected. This mark follows the data from the first datalogger and precedes the data from the second.

CAUTION

The storage module must be disconnected from power for 10 seconds to be certain it places a File Mark in the storage module when reconnected.

A File Mark can be placed in the data by using SMS, the *9 Mode command 3 (not in 21X or CR7) or from a special P96 command in the datalogger program.

The storage module will not store back-to-back file marks. If a File Mark is the last thing stored in memory, a second File Mark will not be stored.

4.2 Pointers

The storage module has several internal pointers which are used to keep track of data for both storage and retrieval operations.

The **Display Location Pointer (DLP)** is used to display storage module data. Ordinarily, when the storage module is connected to a datalogger, the DLP will be at the beginning of the current file. The DLP can be positioned anywhere within the data, using the nnnnnnG command (see Appendix B). Data can then be 'dumped' to the user device using one of the appropriate commands (nnnnC, nnnnD or nnnnF). The dump will begin at the DLP and continue until it reaches the **Storage Reference Pointer (SRP)** or until the next File Mark.

The **Storage Reference Pointer (SRP)**, indicates the next location to be written to in the storage module. It will always be at the end of data in the storage module.

The **Dump Pointer** is an internal storage module pointer used for keeping track of the current start-of-dump for storage module-to storage module data dumps and for the data retrieval options of the SMS program. The user can move the Dump Pointer with the 4H command (see Appendix B). The Dump Pointer marks the end point of the previous data dump and thus the start-of-dump location for the next dump. Moving this pointer ‘loses’ this reference point, which can cause problems with subsequent dumps.

4.3 Data Formats – Space Requirements

The modules store data in the format it is sent to them. There is no conversion or encoding of the data received before it is stored.

Data can be sent to the module in either the Campbell Scientific Final Storage Format (binary) or in the Printable ASCII format. One low resolution data point requires two bytes in binary format. Storing ASCII data requires 10 bytes per data point, therefore the binary option should be used whenever possible.

Bytes from the storage module input buffer are permanently stored in byte-pairs. The Campbell Scientific datalogger’s Final Storage Format data are always grouped in pairs. Printable ASCII may have a single byte left in the input buffer when the PE line drops. In this case, the byte is left in the input buffer until another transmission occurs. It will be paired with the first byte and stored in permanent storage with the current data.

If a single byte remains in the input buffer when power is disconnected from the storage module, it will be stored with a null character (ASCII Code 0) as the second byte the next time external power is applied. A File Mark is stored at power-up. If there is an added null character, it will be placed before a File Mark.

4.4 Available Storage

The flash memory used within the modules is divided into 64 Kbytes blocks, within the memory chips themselves. One limitation of flash memory is that it must be erased before it is possible to write data to it. It is only possible to erase entire blocks of memory, in this case, 64 Kbytes at a time.

If the module is being used as Fill and Stop, this is of no consequence as the memory will have been entirely erased before use. The module will store data until every memory block has been filled.

However, when used as Ring Memory, once the module has filled it must erase the next block of memory before it can “continue writing around the ring”. Erasing a block takes approximately one second, so if data are still streaming into the module, the erase process must take place in advance of writing to that block.

The consequence of this process is that the module must erase blocks of the oldest data in advance. The modules initiate the erase process 24,000 bytes before the end of the current block. In the worst case the size of the erased section of the module will be 64 Kbytes plus 24,000 bytes. Table 4-1 lists

effective capacity for the SM4M and SM16M configured as ring memory. The effective size of the memory can be calculated by taking the storage module size minus 4 bytes per block (used for internal marking purposes), MINUS the worst case erased data size.

| Table 4-1. Ring-Memory Effective Memory Capacity | | |
|---|--------------|----------------------------|
| Module | Bytes | Low-Res Data Values |
| SM4M | 4104516 | 2052258 |
| SM16M | 16686660 | 8343330 |

The amount of storage available for fill and stop memory is 89524 bytes or 44762 low-resolution data values greater than the above (the last eight bytes of memory cannot be written to).

The module will only store data up to the end of the last complete block of data transmitted before the module becomes full. This means that if data are sent in large blocks and the module becomes full just before receipt of the end of the last block, then the effective capacity will be the above figures minus almost the block size.

4.5 Bad Data

The storage module has mechanisms that detect corrupted data being received from the datalogger. When bad data are received the module will immediately stop storing the data. The datalogger will detect this and retransmit the entire data from the last point that the storage module had confirmed receiving the data.

This process does have some consequence for memory use. Data are stored as received. With flash memory it is not possible to overwrite the previously received data transmission without erasing a complete block of memory. Instead a marker system is used which marks the previously written data as bad. When the data are collected, the “bad” data are skipped so a continuous stream of good data are output. However, the amount of good data that can be stored in the module is reduced by the size of the bad data areas.

“Bad” data can also be stored if the module is unplugged while receiving data from the datalogger or if the module resets due to an electrical transient occurring while data are being stored.

In most cases “bad” data will be rare and the reduction in storage small. The likelihood of significant loss of available storage increases if the length of data transmissions to the module are long, and/or the module is unplugged frequently without taking care to wait until the end of transmission.

The areas with “bad” data are freed for normal storage again either when the module is erased or when the area is erased prior to writing new data.

The only other instances when you might encounter “bad” data are:

Section 4. Storage Module Memory: Details of Data Storage

- The start of dump pointer is manually positioned in the module, prior to requesting data and that position is in the middle of an area of “bad” data.
- A storage module in ring-mode has filled the memory, wrapped around and erased the block containing the start of bad data marker or an area of bad data which straddles flash blocks. The next block containing the remainder of the bad data has not been erased.

In both cases the “bad” data will be collected as normal data and written to a file. However, when the end of bad data marker is encountered it will be treated as if it were a file mark and the data that follows will be written into a new file. In such a case, you will find a small file usually containing some data that is also written to the following file.

Section 5. Data Retrieval

Data retrieval is accomplished on PCs using SMS (part of the PC208W package). Other computers require a software program which makes use of the storage module telecommunications commands (Appendix B). In addition to the software, a hardware interface is required.

5.1 Hardware

There are two interfaces which enable communication between a computer and the storage module:

1. The SC532 Peripheral to RS232 Interface
2. The CR500/510, CR10/10X or CR23X with a suitable cable and interface (not possible with other dataloggers)

The SC532 can function with any computer that has an RS232 port. A software program is required to raise the DTR and RTS (pins 20 and 4, respectively) to activate the storage module (Section 5.2). SMS performs this function automatically.

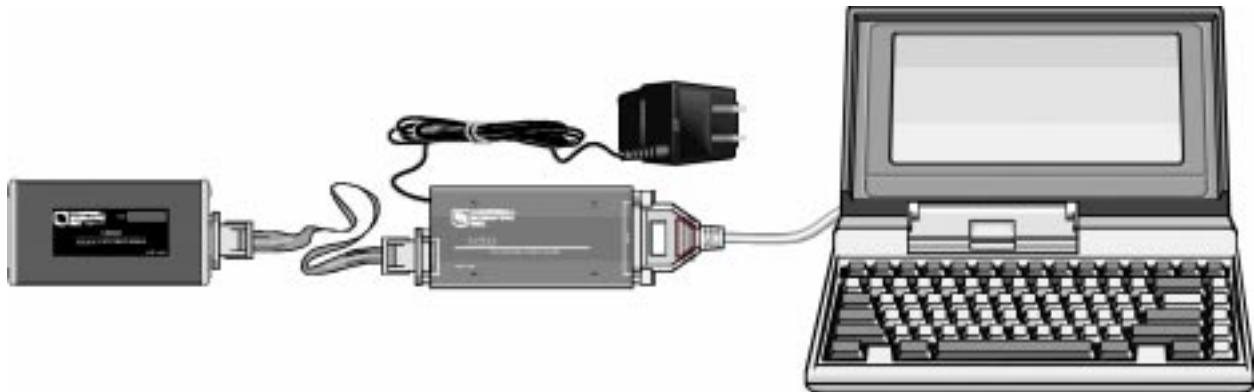

FIGURE 5-1. Storage Module Connected to a Portable PC via an SC532 Interface

5.1.1 SC532

A standard 25-pin ribbon cable (e.g., Campbell Scientific SC25) links the SC532 to the computer's 25-pin serial port. If the computer has a 9-pin serial port, a 9-pin to 25-pin adaptor cable is required. The SC12 9-pin ribbon cable links the storage module to the SC532 (see Figure 5-1).

The SC532 requires 12 VDC (nominal) which is usually provided by plugging the AC/DC adaptor unit into a standard 120 VAC outlet. The use of battery power is possible and is described in the SC532 manual.

5.1.2 Via Datalogger

The storage module is linked to the CR500/510, CR10/10X or CR23X by the SC12 cable. The computer connection is via an SC32A (Figure 5-2), SC929 or SC532/RAD modem interface. With this configuration on the CR23X connect all devices to the 9 pin CS I/O port. Select the “Via Datalogger” option in SMS and select the appropriate datalogger and baud rate.

Please note that communication in this mode is limited to a maximum speed of 9600 baud (19200 on the CR23X), which can make the transfer of large volumes of data a lengthy process, compared to direct connection to a PC, where baud rates up to 115200 are supported.

The SC32A internal SDM blocking jumper should be in place. Without the jumper in place (and sometimes with the SC929/RAD), Windows may report a “framing error” after correctly collecting data with SMS.

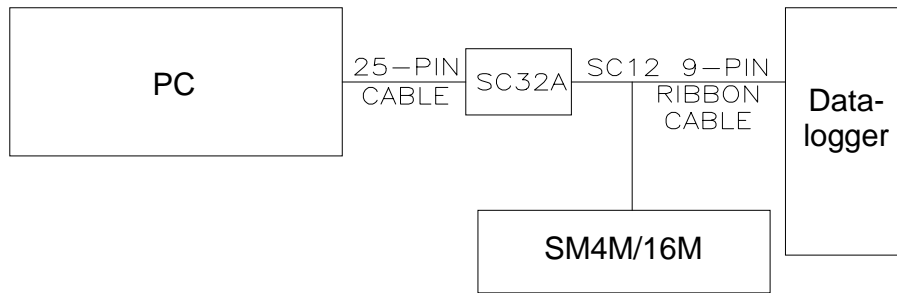

FIGURE 5-2. Communication Via the CR500/510, CR10/10X or CR23X

Communication between a PC and storage module can also take place via the CR23X when the computer RS232 is connected to the CR23X RS232 and the storage module is connected to the CS I/O port (Figure 5-3). This configuration allows baud rates of 19200 and 38400.

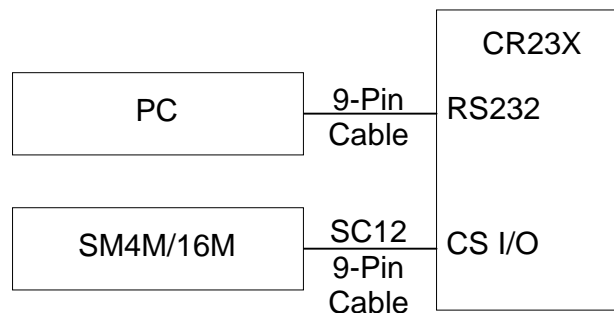

FIGURE 5-3. Communication Via the CR23X

The data can be collected from a module, connected to one of the above dataloggers, via other telecommunication interfaces (e.g., phone lines). Please refer to the PC208W manual for further details.

5.2 SMS

SMS (part of the PC208W software package) is a Windows-based program which provides a simple and efficient way of communicating with the SM4M/SM16M, as well as Campbell Scientific's Card Storage Module (CSM1), Card Reader (MCR1) and PC (PCMCIA) Cards. SMS normally requires the SC532 interface as shown in Figure 5-1 for direct connection. For communication via the CR500/510, CR10/10X or CR23X the setup shown in Figure 5-2 is required. The CR23X can also be used without an SC32A (Figure 5-3). SMS also has a terminal emulator for manual execution of telecommunication commands. See the PC208W manual for more details.

For the most rapid data transfer, use a PC capable of supporting data transfer at 115,200 baud in a Windows environment. This will normally require that the serial ports of the PC are fitted with buffered UARTs, as is the case for most modern machines. Within SMS you should increase the baud rate to 115,200.

5.3 Without SMS

5.3.1 Direct Connection

Connect the storage module to the PC via SC532 as in Figure 5-1. The program or terminal emulator must raise DTR and RTS. Send carriage returns until CR, LF, % is returned. Once the % is returned the storage module is ready to accept the telecommunications commands (Appendix B).

5.3.2 Connection Via CR500/510, CR10/10X or CR23X

Make the connections (Figure 5-2 or 5-3) and establish communications with the datalogger. Send the command 'xM,CR' to the datalogger (where x is the storage module address 1...8). If the connections are correctly made and the storage module is properly addressed, it will send back 'CR, LF, %.' If the attempt to establish communications fails, the datalogger will return '*'.

Once the '%' is received, the storage module telecommunications commands (Appendix B) may be used. SMS can be used when the connection to the datalogger is through the SC32A Optically Isolated RS232 Interface as shown in Figure 5-3.

Section 6. Storing and Retrieving Datalogger Programs

CR500/510, CR10/10X, CR23X, 21X and CR7 programs can be uploaded and downloaded between the datalogger and the storage module in the *D Mode. (OSX and OS7 series PROMs required for 21X and CR7.) Campbell Scientific's SMS software allows programs to be transferred between the computer and the storage module. Using these capabilities, a program can be developed in the computer, stored in the storage module, and then carried to the field and downloaded to the datalogger.

The storage module can store up to eight programs. They are numbered 1 to 8. These are stored in an area of memory separate from that used for data storage.

With the release of the OS series PROMs (OS10, OSX, OS7), the dataloggers were given the capability of automatically loading program 8 if the storage module is connected to the datalogger when the datalogger is powered up. This feature is standard in the CR500/510, CR10/10X and CR23X dataloggers.

21X and CR7 PROMs before the current OSX and OS7 versions do not have the capability to store and directly load programs from the storage module. Programs may be transferred via the DSP4 Heads Up Display (see Section 6.3).

6.1 SMS Storage Module Support Software

Select the Program tab in SMS. See the PC208W manual for more information.

6.2 *D Mode — With Datalogger

The *D Mode is used to transfer programs between the datalogger and storage module. The general commands in Table 6-1 are used to save, retrieve or clear programs from the storage module. See the appropriate datalogger manual for instructions on using the *D Mode.

TABLE 6-1. *D Mode Keyboard Commands

| Key | Display | Description |
|-----|---------|---|
| *D | 13:00 | Enter *D Mode |
| 7XA | 7X:00 | Address Storage Module X |
| 1YA | | Store Program in Storage Module as Y (Y=1..8) |
| 2YA | | Load Program Y from Storage Module |
| 3YA | | Erase Program Y from Storage Module |
| | 13:0000 | command completed |

The program is stored, retrieved, or erased by referring to a program number (1..8) in the storage module. If the program to be retrieved does not exist in the storage module, the error message 'E99' will be displayed.

There are 128 kbytes of memory available for program storage. For example, you can store one 128 kbyte DLD file or 8 x 16kbyte files. Flash memory technology affects the use of memory when storing and erasing programs.

When a program is “erased”, the space it occupied is not freed until the entire program storage area is erased. Thus when you erase a program the amount of free space in the datalogger program area does not increase. However, you can reuse the program number to store another program.

The program storage area can be erased either by issuing one of the module erase/reformat/test commands or by manually deleting all of the programs in the module. In the latter case the module will erase and “tidy-up” the program storage area when the last program is erased.

NOTE

The 21X or CR7 must have only one storage module connected when storing and retrieving programs.

6.3 Using DSP4 Heads Up Display to Store and Retrieve Datalogger Programs

In addition to real-time monitoring of datalogger measurements, the DSP4 Heads Up Display can be used with the CR10/10X, CR23X, 21X (including pre-OSX versions with Extended Software) and the CR7 dataloggers to store and retrieve data and programs. The DSP4 Load and Save program commands allow loading and saving CR10/10X, CR23X, 21X, and CR7 datalogger programs in the storage module.

The DSP4 Flag buttons 1..8 execute the Load or Save command using the storage module as the medium. Up to eight datalogger programs can be saved in the storage module. The program to be saved or loaded is selected by pressing the appropriate push button switch. Refer to the DSP4 Instruction Manual for more details.

Appendix A. *9 Mode — Storage Module Commands

The *9 Mode is used to issue commands to the storage module using the Keyboard/Display or a terminal/computer with all dataloggers except the 21X and CR7. These 'commands' are analogous in many respects to the datalogger functional (*) Modes.

The key sequences for the *9 Mode commands have a generalized format. Using command 1 as an example:

| Key | Display | Explanation |
|-----|---------|--|
| *9 | 09:01 | Enter *9 Mode |
| X | 09:X | Key in the address (x=1 to 8) of the SM to be given the command. |
| A | 9X:00 | Enter the SM address, x; ready to accept a command. |
| 1 | 9X:1 | Key in command 1. Reset SM. |
| A | 01:0000 | Enter command 1. Ready for instruction to effect command 1. |
| 248 | 01:248 | Key in 248 to effect command 1. |
| A | 01: | Execute SM Reset. |

The module then executes the equivalent of the 1249K telecommunications command (Appendix B, note this is not a full 1248K reset as some older modules perform in response to this command which would take too long for field use). After about one minute with the SM4M, or three minutes with the SM16M, the number of megabytes of available data storage is displayed:

01:04 4 for an SM4M
01:16 16 for an SM16M

Most commands have at least one response. Advance through the responses and return to 9X:00 (ready to accept another *9 command) by keying 'A'.

Exit the *9 Mode by keying '*' and the character of the mode you want to switch to (e.g., '*0' to go to the log mode).

TABLE A-1. *9 Mode Commands for Storage Module

| Command | Display | Description |
|----------------|---|--|
| 1 | 01:0000 | RESET: enter 248 to erase all data and programs and reset pointers. While erasing, the SM does a simple check of the memory. The time required to reset an SM4M is approximately 1 minute; SM16M takes nearly 3 minutes. |
| | 01:XX | The number of megabytes of data storage (4 for SM4M, 16 for SM16M). |
| 3 | 03:01 | INSERT FILE MARK at the position of the SRP if a file mark wasn't the last thing placed in the data. 1 indicates that the mark was inserted, 0 indicates that it was not. |
| 4 | 04:XX | DISPLAY/SET MEMORY CONFIGURATION: enter the appropriate code to change configuration 0=ring, 1=fill and stop. |
| 5 | DISPLAY STATUS (A to advance to each window): | |
| | 01:ABCD | Window 1: |
| | AB | Not used |
| | CD | Total number of megabytes |
| | 02:ABCD | Window 2: |
| | ABC | Not used |
| | D | No. of Programs stored (Max=8) |
| | 03:ABCD | Window 3: |
| | A | Errors logged (up to 9) |
| | B | Not Used |
| | C | Memory Config. (0=ring, 1=fill & stop) |
| | D | Memory Status (0=not full, 1=full) |
| | 04:XXXXXX | OS signature (0 if bad OS) |
| 6 | 06:00 | Not used |
| 7 | 07:00 | Not used |
| 8 | 08:00 | Not used |
| 9 | DISPLAY ADDRESSES OF CONNECTED STORAGE MODULES: | |
| | XXXXXXXX | 1 = occupied, 0 = unoccupied |
| | 87654321 | (Addresses 8-1 from left to right) |
| 10 | CHANGE ADDRESS | |
| | 10:0X | X is current address, enter yA to change and then display address where y=1...8. |

Appendix B. Telecommunications Commands

The storage module telecommunications commands can be issued to an storage module either via a direct SC532 connection to the storage module or via a remote connection where the storage module is connected to a datalogger.

Establishing communication between the storage module and a computer/terminal is discussed in Section 5. The commands permit data storage and retrieval, switch setting, status checks and other functions.

If you are making connections through a datalogger, make the connections (Figure 5-4) and establish communications with the datalogger. Send the command 'XM,CR' to the datalogger (where X is the storage module address 1...8). If the connections are correctly made and the storage module is properly addressed, it will send back 'CR, LF, %.' If the attempt to establish communications fails, the datalogger will return '*'.

The storage module is ready for a command when it sends its prompt, '<CR><LF> %'. The successful execution of a command is also indicated by the storage module returning a '<CR><LF> %'. If just a '%' is returned, the command was in error. 'CTRL-S' (XOFF) temporarily halts storage module responses to commands. 'CTRL-C' aborts the response.

The descriptions of some commands refer to the storage module pointers (see Section 4). The **Display Location Pointer (DLP)** is used to display storage module data. The **Storage Reference Pointer (SRP)** indicates the next location to be written to in the storage module. The **Dump Pointer** is an internal storage module pointer used for keeping track of the current start-of-dump for storage module-to-storage module data dumps and for the data retrieval options of the SMS program.

storage module telecommunications commands are similar to datalogger telecommunications commands and consist of numbers and CAPITAL letters. In the following list telecommunications commands are on the left and their descriptions on the right.

A Status

Returns **V**ersion number, **S**witch settings, number of **P**rograms stored, number of good **D**ata **M**emory blocks, number of **E**rrors logged (max. = 255), number of **A**vailable storage locations, number of locations **F**ull, **S**torage **R**eference **P**ointer, **D**isplay **L**ocation **P**ointer, **D**ump **P**ointer and **C**hecksum (sum of all transmitted ASCII characters since last %; wraps around at 8192 bytes).

The number of Errors logged is a count of bad characters received from the datalogger and/or the number of times the module has reset itself as a result of some unknown cause. Contact Campbell Scientific for advice if this counter increments regularly. Unlike previous modules this counter does not increment if corrupted characters are received in telecommunications mode.

Example: V1 S1400 P0 M64 E0 A2052258 F1 R2 L2 D2 C2226 is the expected response to the A command after an SM4M has been reset.

NOTE:- in Ring mode, when data storage has gone around the memory more than once the Number of Locations Full will fluctuate. This is because memory is erased in 64 Kbyte blocks and filled an output array at a time (Section 4).

NOTE

Refer to the L command for a discussion of the switch settings.

**AA
Advanced Status**

Example: B65536 T4194304 U131068 P131072 A00000000 F2097019 W00 C3060 is the expected response to the AA command after a SM4M has been reset.

Data Flash **B**lock size in bytes, **T**otal Data Flash in bytes, **L**argest Unused program space in bytes, **T**otal Program storage area in bytes, **A**ctive programs stored (A10005008 means programs 1,5 and 8 are stored), **F** Number of locations left until oldest data will be overwritten, **W**rap status flag (00 = not wrapped round, 01 = not wrapped around but beginning of oldest data has been erased, 11 = wrapped around and oldest data being erased, and **C**hecksum (sum of all transmitted ASCII characters since last %; wraps around at 8192 bytes).

nnnnB

Move the DLP back nnnn output arrays from its current position. If it is fewer arrays to the beginning of the file (File Mark), the DLP will be placed at the beginning of the file. **B** is the same as 1B. Status is displayed following execution of command. This command may take some time to complete.

**nnnnC
Comma Delineated
ASCII Dump**

Dump nnnn output arrays from the location of the DLP. The dump stops if the next file mark or the Storage Reference Pointer is reached. 'C' is the same as '1C'. '0C' means dump continuously. Status is displayed following execution of command.

**nnnnF
Binary Dump**

Dump nnnn locations (two bytes each) until the next File Mark from the location of the DLP. The dump stops if the Storage Reference Pointer is reached, followed by two bytes displaying the signature of the transmitted data. No data conversion is made. 'F' is the same as '1F'. '0F' means dump continuously. The status is not displayed following command execution.

**nnnnnG
Go To Location nnnnn**

Use this command to position the Display Location Pointer to any location in the storage module. The Status is then displayed.

**01G
Go To Last File**

This command causes the Display Location Pointer (DLP) to move to the beginning of the current file. The status is then displayed.

**08G
Go To Dump Pointer**

The Display Location Pointer (DLP) is advanced to the Dump Pointer position. The Dump Pointer is set to the beginning of memory when the storage module is reset. It is advanced only by the CR10/10X (*9) storage module-to-storage module Dump command, the '4H' command, and by SMS.

**09G
Go To Next File**

The Display Location Pointer (DLP) is advanced to the beginning of the next file. The DLP is advanced as the storage module reads through the data until a File Mark or the Storage Reference Pointer is encountered. For long files, the delay involved could be noticeable. The status is displayed following command execution. This command can be used to locate every file in the storage module.

| | |
|---|---|
| 09GG Go To Next File with Progress Indicator | Like 09G but this command outputs the value of the DLP every second as it moves through memory, as the module searches for the next file mark. |
| 0H Store | The storage module will store all data received on the Transmit Data (TD) line until the storage module is deactivated when the PE (Pin 6) and CLK/HS (Pin 7) lines go low. External power must remain applied for at least 5 ms following deactivation of PE and CLK/HS for 'housekeeping.' The storage module stores two bytes at a time. If the total number of bytes transmitted is an odd number, a NULL character will be added at the end of the transmission. This command is not available in telecommunications via CR500/CR510, CR10/10X or CR23X. |
| 4H Move Dump Pointer To Display Location Pointer | The Dump Pointer is moved to the current position of the Display Location Pointer. Refer to command '08G' regarding the Dump Pointer. This command is not intended for general use. |
| 9H Store File Mark in Data | Used to designate a new area of memory in the storage module. A File Mark is automatically placed in the storage module's memory when the storage module is connected to a power source (datalogger or retrieval interface), when the datalogger compiles a program containing Instruction 96, or under program control. Status is displayed following command execution. |
| nI Dump Program n (n = 1...8) | If program 'n' is found, the storage module dumps it to the user device, otherwise it sends a null program (30 05 05 HEX) followed by a prompt without a carriage return and line feed. |
| nJ Store Program n (n = 1...8) | The storage module responds with '<' after which the storage module stores program data received on its TD line, recording its start position in the program directory. Subsequent data does not write over stored datalogger programs unless the directory entry is cleared or modified. Programs <i>must</i> start with the Start ASCII character (7D HEX) and end with two CTRL-E (05 05 HEX) characters. Status is displayed following command execution. This command is not available when communicating with the storage module using an RF Modem. |
| nJJ Store Program n, with Checksum Signature | Like the nJ command, but the module outputs a 2 byte CSI checksum signature in response to the 05 05 HEX termination characters, which allows easy validation that the program has been received correctly. |
| n0nJ Clear Program n (n = 1...8) | Clears directory entry for program 'n' and frees the memory space for data storage – this only becomes available for further program storage if all programs are deleted. Example: To clear program 7, the command is 707J. Status is displayed following command execution. |
| 1243K Reset Error Counter | This command resets the communications error counter (the number beginning with 'E') to zero, then displays the status line. Neither the programs nor the data stored in the module are affected by this command. |

**1248K
Reset Storage Module**

Erases all data and programs, resets all pointers, tests memory and places a File Mark at the beginning of memory. If a bad flash memory block is encountered, the storage module will use only the good memory up to the bad block. The number of good flash memory blocks is indicated in the Status. During Reset, a plus (+) for each block written to, and a minus (-) for each block successfully read is output by the storage module. An 'X' is output for each RAM which cannot be read successfully. The status is displayed following command execution. If the storage module returns a '%' without a '<cr><lf>,' the memory test failed.

CAUTION

ALL DATA ARE LOST WHEN THE STORAGE MODULE IS RESET. Be sure to collect data before resetting the storage module.

**1249K
Quick Reset**

This command is similar to the 1248K command — it also erases all data and programs. However, it does not test memory, it simply resets the memory pointers and instructs the flash memory to erase itself. This is much faster than the 1248K command and is designed for routine erasure of the card. If the module has been corrupted, use the 1248K command instead. A module with damaged memory requires a memory test to determine how much good memory remains intact.

**abfeL
Switch Settings**

'a' is the storage module Address Switch. When used with a CR500/510, CR10/10X or CR23X, this switch can be set to 1...8. The address has no effect when used with other Campbell Scientific dataloggers. *Following reset, the storage module address defaults to 1.*

'b' is the Baud Rate Switch – this is not currently used in the flash modules. This switch always defaults to a value of 4, for compatibility with older modules.

'f' is the Fill and Stop/Ring Memory Status Switch. If set to '0,' the memory is ring type. If '1,' the memory is set to Fill and Stop and once memory is full, further efforts to write to the storage module are aborted. *The memory status switch defaults to '0' (ring memory) following storage module Reset.*

'e' is the Encode ASCII Switch. This switch is not currently supported in the flash module, it defaults to a value of zero indicating data are stored without any encoding.

Entering 9 for switch settings leaves the switch setting unchanged. Example: 9990L would only disable the Encode ASCII function. Since position is important, the 9's are used to fill the first 3 spaces without changing the settings.

**M or *
Disconnect**

The storage module is deactivated to a low power standby mode. If the communications interface is the CR500/510, CR10/10X, CR23X the datalogger "*" prompt will be returned.

**N
OS Signature**

Returns the storage module operating system signature. If this command returns '0,' the operating system is bad.

Appendix C. Storage Module 9-Pin Connector

The pins on the 9-pin sub-miniature D connector on the storage module are numbered 1 to 9. A general description of the function of each pin follows:

- Pin 1 (Input) 5 VDC Supply provides power to the storage module. 5 ± 0.3 VDC @ 100mA. Processor held in reset when external power falls below 4 VDC. Damage to storage module hardware can occur if input on Pin 1 exceeds 5.5 VDC. Low power standby mode current drain is less than 200 μ A.
- Pin 2 (Input) Power and signal GROUND.
- Pin 3 (Output) RING LINE. Not used.
- Pin 4 (Output) RECEIVE DATA (RD) line. The storage module transmits its responses to Telecommunications commands asynchronously (0 to 5 VDC) on this line. Data format is 8-bit, 1 start bit and 1 stop bit. Refer to Section 3.1 for baud rate options. This line is held high while the storage module is active in the Printer Enable Method (data storage).
- Pin 5 (Input) MODEM ENABLE line. Not used.
- Pin 6 (Input) PRINTER ENABLE (PE) in Printer Enable Method or SYNCHRONOUS DEVICE ENABLE (SDE) line in SDC Method. If the storage module is externally powered, the PE line is high (5 VDC) and Pin 7 (CLK/HS) is low (0 VDC), the processor is set to receive data asynchronously on Pin 9 (TD). When the PE line is dropped, data remaining in the input buffer are stored and the location pointers are saved. The processor then enters an inactive, low power, standby state.

If the processor is still active from a previous transmission of data and the PE line is raised again, the processor will be forced to its inactive state; data from the previous transmission will be lost and the current transmission will be ignored. Normal operation will return with the next low to high PE transition. Switch bounce on the PE line can cause the processor to go inactive after the PE line stabilizes in its high state.
- Pin 7 (Input) CLOCK/HANDSHAKE (CLK/HS) line. For data storage, CLK/HS must be low. For data retrieval using Telecommunications Commands (see Appendix B) CLK/HS must be high when the processor is activated by the PE line going high. CLK/HS must remain high during Telecommunications. To exit the Telecommunications Command State, lower both the PE and CLK/HS lines.
- Pin 8 (Input) TAPE ENABLE / 12V power line. Not used.
- Pin 9 (Input) TRANSMIT DATA (TD) Data are received by the storage module on this line. Data are received asynchronously (0 to 5 VDC) 8-bit, 1 start and 1 stop bit. The idle state (stop bits) on this line is 0 VDC. The first byte transmitted to the storage module should be more than 200 μ s after the PE line has activated the processor.

Appendix D. Upgrading the Operating System

The storage module operating system is stored in flash memory. (It is NOT deleted when the storage module is reset.) It is possible to upgrade the operating system using Campbell Scientific's CSOS download utility. Please contact Campbell Scientific for a copy of this utility compatible with the SM4M and SM16M if you need to change the module operating system.

To load the operating system you will need to connect the module to a PC running Windows, via an SC532 interface. Please follow the instructions supplied with CSOS.

Do not attempt to load any operating system other than that designed for these storage modules. Do not disconnect the power supply to the module during the upgrade process, otherwise the module memory may be corrupted requiring a factory repair.

NOTE

After CSOS indicates the download is complete, wait until the green LED on the storage module goes out before using the storage module. The green LED remains on until the storage module completes the OS upgrade.
