

# Distance Sensor

## Model SR50

The SR50 is a rugged, acoustic distance sensor that is manufactured by Campbell Scientific Canada. It measures the elapsed time between emission and return of an ultrasonic pulse. This measurement can be used to determine snow or water depth. An air temperature measurement is required to correct for variations of the speed of sound in air.

The SR50 was designed to meet the stringent requirements of measuring depths and uses a multiple echo processing algorithm to help ensure measurement reliability. The SR50 is compatible with our CR510, CR10(X), 21X(L), CR23X, CR7, CR1000 and CR5000 dataloggers.

### Specifications

Power Requirements: 9-16 VDC, typically powered by the datalogger's 12 VDC power supply.

Power Consumption: 2 mA quiescent  
250 mA measurement peak

Measurement Time: 0.6 seconds typical  
3.0 seconds max

Output Options (selected by configuring internal jumpers):  
SDI-12, Pulse train, or Serial ASCII

Measurement Range: 1.6 to 32.8 ft (0.5 to 10 m)

Beam Acceptance: Approx. 22°

Accuracy:  $\pm 0.4$ " (1 cm) or 0.4% of distance to target  
whichever is greatest

Operational Accuracy: 1" typical

Resolution: 0.004" (0.1 mm)

Operating Temperature: -45° to +50°C

Maximum Cable Length: 200 ft (60 m) for SDI-12 output;  
984 ft (300 m) for pulse train output

Dimensions: length 12.2" (31 cm)  
diameter 3" (7.5 cm)

Weight: 2.9 lbs (1.3 kg)

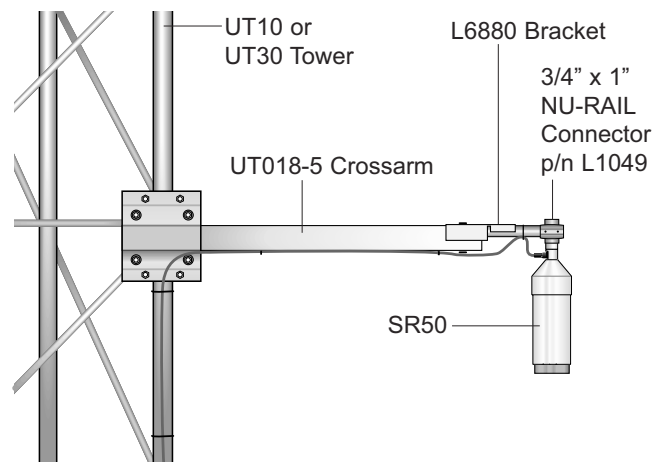
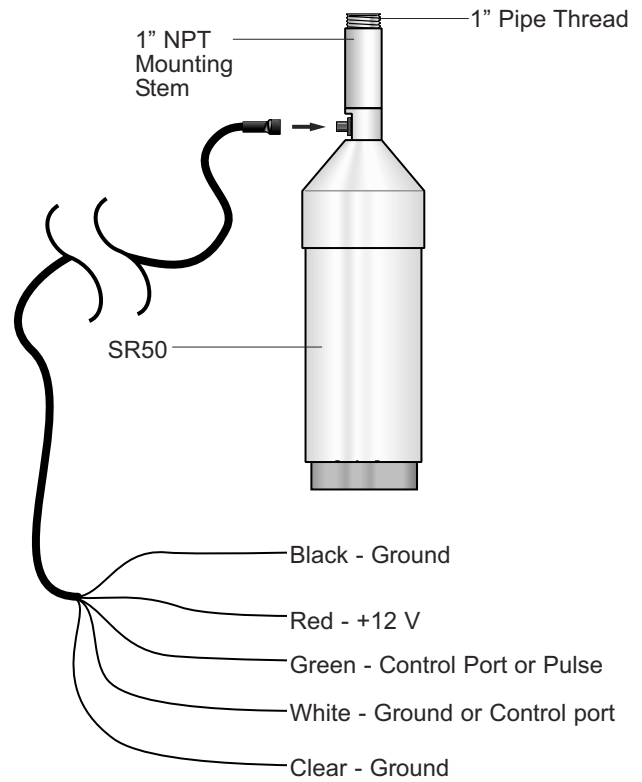

### Ordering Information

SR50-L: User specifies lead length, which is entered in feet after the L.  
For example, an SR50-L10 orders an SR50 with a 10 foot lead length.