

# INSTRUCTION MANUAL



## **SR50A Sonic Ranging Sensor**

---

October 2011



Copyright © 2007  
Campbell Scientific (Canada) Corp.

## WARRANTY AND ASSISTANCE

This equipment is warranted by CAMPBELL SCIENTIFIC (CANADA) CORP. ("CSC") to be free from defects in materials and workmanship under normal use and service for **twelve (12) months** from date of shipment unless specified otherwise. \*\*\*\*\* **Batteries are not warranted.** \*\*\*\*\* CSC's obligation under this warranty is limited to repairing or replacing (at CSC's option) defective products. The customer shall assume all costs of removing, reinstalling, and shipping defective products to CSC. CSC will return such products by surface carrier prepaid. This warranty shall not apply to any CSC products which have been subjected to modification, misuse, neglect, accidents of nature, or shipping damage. This warranty is in lieu of all other warranties, expressed or implied, including warranties of merchantability or fitness for a particular purpose. CSC is not liable for special, indirect, incidental, or consequential damages.

Products may not be returned without prior authorization. To obtain a Return Merchandise Authorization (RMA), contact CAMPBELL SCIENTIFIC (CANADA) CORP., at (780) 454-2505. An RMA number will be issued in order to facilitate Repair Personnel in identifying an instrument upon arrival. Please write this number clearly on the outside of the shipping container. Include description of symptoms and all pertinent details.

CAMPBELL SCIENTIFIC (CANADA) CORP. does not accept collect calls.

Non-warranty products returned for repair should be accompanied by a purchase order to cover repair costs.



**CAMPBELL SCIENTIFIC**  
C A N A D A C O R P .

11564 - 149 street - edmonton - alberta - T5M 1W7  
tel 780.454.2505 fax 780.454.2655

[www.campbellsci.ca](http://www.campbellsci.ca)

**Warning!**

Always disconnect the sensor before opening.

**Avertissement!**

Toujours débrancher le capteur avant de l'ouvrir.

This Device complies with Part 15 of the FCC Rules.

Operation is subject to the following two conditions:

- (1) This device may not cause harmful interference, and
- (2) This device must accept any interference received, including interference that may cause undesirable operation.

## TABLE OF CONTENTS

1	Specifications.....	4
2	Introduction.....	6
3	Operation .....	7
3.1	Quality Numbers.....	8
3.2	Temperature Compensation for SR50A version.....	9
3.3	Temperature Compensation for SR50AT version .....	10
3.4	SDI-12 Operation.....	11
3.4.1	SDI-12 Wiring .....	11
3.4.2	SDI-12 Addresses .....	11
3.4.3	SDI-12 Commands.....	12
3.5	RS-232 Operation .....	14
3.5.1	RS-232 Wiring.....	14
3.6	RS-485 Operation .....	15
3.6.1	RS-485 Wiring.....	15
3.7	RS-232 and RS-485 Settings .....	16
3.7.1	BAUD Rate Setting.....	19
3.7.2	Address .....	19
3.7.3	Operational Mode Setting.....	19
3.7.3.1	Measure in Poll Mode.....	20
3.7.3.2	Auto Measure Auto Output Mode .....	20
3.7.3.3	Auto Measure Polled Output Mode .....	21
3.7.4	Distance to Target or Depth.....	21
3.7.5	Distance to Ground .....	21
3.7.6	Measurement Interval Units.....	22
3.7.7	Measurement Interval Value.....	22
3.7.8	Output Unit .....	22
3.7.9	Quality Output .....	22
3.7.10	Temperature Output.....	23
3.7.11	Diagnostics Output.....	23
3.8	Serial Commands.....	23
3.8.1	Setup command.....	23
3.8.2	Poll command .....	23
3.8.3	Information command.....	23
3.8.4	Temperature Input command.....	24
3.9	RS-232/RS-485 Data Output Format.....	24
3.9.1	Measurement Output.....	24
3.9.2	Information Message Output .....	27
4	Sensor Mounting and Installation.....	29
4.1	Beam Angle .....	29
4.2	Mounting Height.....	30
4.2.1	Reference point .....	30
4.3	Mounting Options .....	30
5	Maintenance.....	33
6	Disassembly/Assembly Procedures .....	34

7	Jumper Settings .....	38
8	SR50A Firmware Updates .....	39
9	Data Interpretation .....	41
10	Datalogger Program examples .....	42
10.1	Programming Example 1 .....	42
	SR50A SDI-12 “M1!” CR10X Datalogger.....	42
10.2	Programming Example 2 .....	44
	SR50AT SDI-12 “M3!” CR10X Datalogger .....	44
10.3	Programming Example 3 .....	46
	SR50A SDI-12 “M1!” CR1000 Datalogger .....	46
10.4	Programming Example 4 .....	47
	SR50AT SDI-12 “M4!” Snow Depth Output CR1000.....	47
10.5	Programming Example 5 .....	49
	SR50A RS-232 Mode CR1000.....	49
10.6	Programming Example 6 .....	51
	SR50AT RS-232 Mode CR1000 .....	51
11	Warnings/Cautions.....	53
<b>Appendix A - SR50AH Heater Option</b>		
1	Heater Introduction .....	54
2	Specifications.....	54
2.1	Heating Cable Requirements .....	54
3	Maintenance.....	55
<b>Appendix B – Optional Open Faced Transducer for Harsh Environments</b>		
1	General.....	60
<b>Appendix C – SR50A-316SS and SR50AT-316SS Options</b>		
1	Introduction.....	61

**TABLE OF FIGURES**

Figure 1	SR50AT-CBL.....	10
Figure 2	SR50A to MD485 wiring .....	16
Figure 3	Beam Angle Clearances .....	29
Figure 4	Distance from edge of transducer housing to grill .....	30
Figure 5	SR50A Mount - mounted parallel to pipe .....	31
Figure 6	SR50A Mount - mounted perpendicular to pipe .....	31
Figure 7	SR50A - mounted using Nurail and C2151 mounting stem.....	32
Figure 8	Disconnect cable from sensor.....	34
Figure 9	Remove 6 screws from the transducer housing.....	35
Figure 10	Remove transducer housing and disconnect wires.....	35
Figure 11	Location of Desiccant in transducer housing assembly .....	36
Figure 12	Remove and Replace Desiccant .....	36
Figure 13	Remove the 2 flat philips screws to expose the PCB .....	37

## 1 Specifications

<b>Power Requirements:</b>	9-18 VOLTS D.C.
<b>Power Consumption:</b>	<b>Quiescent</b> SDI-12 Mode < 1.0mA RS-232/RS485 Mode < 2.25mA <sup>Note1</sup>
	<b>Peak Measurement Current</b> 250 mA typical
<b>Measurement Time:</b>	Less than 1.0 second
<b>Selectable Outputs:</b>	SDI-12 (version 1.3) RS-232 (1200 to 38400 BAUD) RS-485 (1200 to 38400 BAUD)
<b>Measurement Range:</b>	0.5 to 10 meters
<b>Accuracy:</b>	±1 cm or 0.4% of distance to target (whichever is greater) Excludes temperature compensation errors. An external temperature compensation is required for the SR50A..
<b>Resolution:</b>	0.25mm
<b>Required Beam Angle Clearance:</b>	30°
<b>Operating Temperature:</b>	-45°C to +50°C
<b>Maximum Cable Length:</b>	SDI-12 60 meters RS-232 (9600 BAUD or less) 30 meters RS-485 300 meters <sup>Note2</sup>
<b>Cable Type:</b>	4 conductor, 2-twisted pair, 22 AWG, Santoprene jacket
<b>Chassis Types:</b>	Aluminum, or 316 stainless steel
<b>Dimensions:</b>	Length 10.1 cm Diameter 7.6 cm

**Weight:**

Aluminum chassis:	375g (13.2oz)
Stainless steel chassis:	795g (28oz)
Cable (SR50A) 15 feet:	0.25kg (0.55lbs)

**Temperature**

<b>Measurement (SR50AT):</b>	0°C to +50°C $\pm$ 0.2°C
	-45°C to 0°C $\pm$ 0.75°C

Note 1: The quiescent current draw is less than 1.25mA if the BAUD rate is 9600 BAUD or less.

Note 2: Power supply must not drop below 11.0 Volts or heavier gauge wire is required

## **2 Introduction**

The SR50A Sonic Ranging Sensor measures the distance from the sensor to a target. The most common applications are measuring snow depths and water levels. The sensor is based on a 50 kHz (Ultrasonic) electrostatic transducer. The SR50A determines the distance to a target by sending out ultrasonic pulses and listening for the returning echoes that are reflected from the target. The time from transmissions to return of an echo is the basis for obtaining the distance measurement.

Since the speed of sound in air varies with temperature, an independent temperature measurement is required to compensate the distance reading for the SR50A. A simple calculation is applied to initial readings for this purpose.

The SR50AT version of sensor comes with a temperature probe that will allow the SR50AT to output temperature compensated values.

The SR50A is capable of picking up small targets or targets that are highly absorptive to sound, such as low density snow. The SR50A makes use of a unique echo processing algorithm to help ensure measurement reliability. If desired, the SR50A can also output a data value indicative of measurement quality.

The SR50A was designed to meet the stringent requirements of snow depth measurement which makes it well suited for a variety of other applications. The rugged aluminium housing is built to withstand harsh environments and offers several mounting options.

### 3 Operation

The SR50A has several output formats: SDI-12, RS-232 and RS-485. The SR50A is shipped from the factory configured as an SDI-12 sensor (address 0). By moving a set of three jumpers inside the SR50A the output type can be optionally set from SDI-12 to RS-232 or RS-485. Refer to Section 6 for details on opening the SR50A and Figure 7 for the optional jumper settings.

The SR50A performs multiple echo processing regardless of output formats. The SR50A bases every measurement on several readings and applies an algorithm to improve measurement reliability.

The distance to target readings that are obtained from the sensor are referenced from the metal mesh on the face of the transducer. The SR50A projects an ultrasonic beam that can pick up objects in its field of view that is 30° or less. The closest object to the sensor will be detected if it is within this field of view. Unwanted objects must be outside the field of view. If a target is in motion, the SR50A may reject a reading if the target distance changes at a rate of 4 centimetres per second or more.

The SR50A will complete a measurement and output the data typically in 1 second. In RS-232 and RS-485 Serial modes the output data transmission is completed within one second for BAUD rates of 9600 and above. The total time for an SDI-12 Measurements can exceed 1 second due to the long communications times associated with the 1200 BAUD data rate.

If the SR50A rejects a reading or does not detect a target, zero will be output for distance to target or -999 for depth values.

### 3.1 Quality Numbers

Measurement quality numbers are also available with output data; these give an indication of the measurement certainty. The quality numbers have no units of measure but can vary from 152 to 600. Numbers lower than 210 are considered to be measurements of good quality. A value of zero however, indicates a reading was not obtained. Numbers greater than 300 indicate that there is a degree of uncertainty in the measurement. Causes of high numbers include:

- sensor is not perpendicular to the target surface
- target is small and reflects little sound
- target surface is rough or uneven
- target surface is a poor reflector of sound (extremely low density snow)

Quality number range	Quality range description
0	Not able to read distance
152-210	Good measurement quality numbers
210-300	Reduced echo signal strength
300 to 600	High measurement uncertainty

It is not necessary to make use of the quality numbers but they can provide additional information such as an indication of surface density in snow monitoring applications. The quality numbers will increase during snowfall events consisting of low-density snow.

### 3.2 Temperature Compensation for SR50A version

The SR50A version of the sensor does not include a temperature sensor to compensate the speed of sound for variations in air temperature. Temperature corrections for the speed of sound will need to be applied to the readings in either post processing or by the measurement/monitoring device. Campbell Scientific recommends the Model 107 air temperature probe for this purpose. A radiation shield is also recommended. Temperature compensation must be applied to the sensor output using the following formula:

$$DISTANCE = READING_{SR50A} \sqrt{\frac{T^{\circ}KELVIN}{273.15}}$$

**FORMULA 1. Temperature Compensation**

The SR50A calculates a distance reading using the speed of sound at 0°C (331.4 m/s). If the temperature compensation formula is not applied, the distance values will not be accurate for temperatures other than 0°C.

### 3.3 Temperature Compensation for SR50AT version

The SR50AT version of the sensor includes a temperature sensor to compensate the speed of sound for variations in air temperature. The temperature sensor is incorporated into the SR50AT Cable as shown in Figure 1 SR50AT-CBL



Figure 1 SR50AT-CBL

By default the temperature correction will be on for RS-232 and RS-485 modes. For the SDI-12 output mode the datalogger must include a measurement command that has temperature in the output. Otherwise the internal temperature correction will not be applied. The following “M” commands automatically apply the temperature compensation to the readings from the SR50AT:

M2, M3, M4, M7 and M8  
(see section 3..4.3 for the complete list of SDI-12 commands).

Command M9 is used to obtain a temperature measurement without a distance reading. The M9 command makes it possible for the SR50AT to function as an SDI-12 temperature sensor.

If the internal SR50AT temperature correction needs to be bypassed, the temperature output setting will need to be turned off for RS-232 and RS-485 modes. Using measurement commands M, M1, M5 and M6 in SDI-12 mode will not use the SR50AT probe to compensate for the speed of sound. The compensation will then need to be done externally as for the SR50A version.

A radiation shield is required for the SR50AT temperature probe. Without a radiation shield the heating of the sensor from the sun's radiation can cause large errors in the temperature reading and this will be reflected in the distance measurement.

### 3.4 SDI-12 Operation

SDI-12 is a Serial Digital Interface standard that is used for communication between data recorders and sensors. Most Campbell Scientific dataloggers are SDI-12 compatible.

#### 3.4.1 SDI-12 Wiring

It is recommended to power down your system before wiring the SR50A. Never operate the sensor with the shield wire disconnected. The shield wire plays an important role in noise emissions and susceptibility as well as transient protection.

<b>Color</b>	<b>Function</b>	<b>Connection</b>
Black	Power Ground	Power Ground
Red	+12VDC Power	Power Source
Green	SDI-12 I/O	Recorder/Reader SDI-12 Com port or control port
White	Not Used	Ground
Clear	Shield	Shield/Earth Ground

#### 3.4.2 SDI-12 Addresses

The SR50A can be set to one of ten addresses (0 to 9) which allows up to ten sensors to be connected to a single digital I/O channel (control port) of an SDI-12 datalogger.

The SR50A is shipped from the factory with the address set to 0. The address on the SR50A can be changed by sending an

SDI-12 change address command. The change address command can be issued from most SDI-12 recorders. For some Campbell Scientific dataloggers the SDI-12 transparent mode will need to be entered to change the address. When it is necessary to measure more than one SR50A, it is easiest to use a different control port for each SR50A instead of changing the address. If additional control ports are not available, then the address will need to be changed.

To change the address of a sensor that has the default address of 0 to the address of 1 the following command can be sent:

“0A1!”

Only one sensor of the same address should be connected when using the change address command.

### 3.4.3 SDI-12 Commands

The SDI-12 protocol has the ability to support various measurement commands. The SR50A supports the commands that are listed in the following table.

The different commands are entered as options in the SDI-12 recorder instruction. The major difference between the various measurement commands are the data values that are returned. The user has the option to output the distance to target in either meters or feet, or to include the measurement quality numbers or temperature values (SR50AT version only outputs valid temperature values).

If the SR50A is unable to detect a proper echo for a measurement, the sensor will return a zero value for the distance to target value.

In order to obtain the Snow Depth values (aM4! or aM8!) the user must properly set the Distance to Ground value in the SR50AT sensor. This can be done by sending an extended command in SDI-12 mode or by using the setup menu in RS-232 or RS-485 modes.

SDI-12 Command	Command Function/Description	Values Returned
aM!	Distance-Meters	D
aM1!	Distance-Meters, Quality Number	D, Q
aM2!	Distance-Meters, Temperature °C	D, T <sup>Note1</sup>
aM3!	Distance-Meters, Quality Number, Temperature °C	D, Q, T <sup>Note1</sup>
aM4!	Snow Depth Meters, Quality Number, Temperature	SD, Q, T
aM5!	Distance-Inches	D
aM6!	Distance-Inches, Quality Number	D, Q
aM7!	Distance-Inches, Quality Number, Temperature °C	D, Q, T <sup>Note1</sup>
aM8 <sup>†</sup>	Snow Depth Inches, Quality Number, Temperature	SD, Q, T <sup>Note1</sup>
AM9 <sup>†</sup>	Temperature °C	T <sup>Note1</sup>
aMC! aMCn!	Measurement Commands with Checksum See aM and aM1- aM8	Output is the same as aM, aM1-aM8 Checksum is added
aC!	Concurrent Measurement Command Distance-Meters	D
aCn!	Concurrent Measurements Same as M1 – M8	Output is the Same as M1 – M8
aCC! aCCn!	Concurrent Measurement Commands with Checksum. See aM and aM1- aM8	Output is the same as aM, aM1-aM8 Checksum is added
aD0!	Send Data	Dependent upon command Sent
aV!	Verification command	S1,S2,V,WD S1 = Firmware Signature S2 = BootRom Signature V = Supply Voltage <sup>Note1</sup> WD = Watch Dog Errors
aI!	Send Identification	013CAMPBELLSR50A 2.0SN SN = Serial number (5 digits)
?!	Address Query	a
aAb!	Change Address command	b is the new address
aXM;D.DDD! Extended command	Set the distance to ground parameter in the SR50A. The distance must be in meters with no more than 3 decimal places.	a Address is returned
aXI;DDD.DD! Extended command	Set the distance to ground parameter in the SR50A. The distance must be in Inches with no more than 2 decimal places.	a Address is returned
aXT;CC.CC! Extended command	Provide the SR50A with a temperature value to perform on board temperature compensation. The temperature must be in degrees Celsius with a maximum of 7 characters including sign and decimal.	a Address is returned
aR0!	Returns the Distance to Ground Setting in the SR50A. The units returned are in Meters	DG
aR1!	Returns the Distance to Ground Setting in the SR50A. The units returned are in Inches	DG
aR2!	Returns the temperature sent to the SR50A for Internal Temperature compensation. This value remains the same unless power is cycled or a new temperature values is sent.	T

Where a = address of SDI-12 device.

Where n = numbers 1 to 9

NOTE 1: (SR50AT version only)

### 3.5 RS-232 Operation

The SR50A sensor comes from the factory with the internal jumpers set to SDI-12 mode. To use the SR50A in the RS-232 mode of operation the jumpers will need to be set as outlined in Section 7.

#### 3.5.1 RS-232 Wiring

The following table/diagram illustrates the wiring for the SR50A in RS-232 mode.

Color	Function	Connection
Black	Power Ground	System Ground and/or RS-232 Receiver Ground (Pin 5 of a computer (DTE) DB-9 connector)
Red	+12VDC Power	Power Source
Green	RS-232 (SR50A Output)	Recorder/Reader RS-232 Input (Pin 2 of a computer (DTE) DB-9 connector)
White	RS-232 (SR50A Input)	Recorder/Reader RS-232 Output (Pin 3 of a computer (DTE) DB-9 connector)
Clear	Shield	Shield/Earth Ground

The following is an illustration of an SR50A using a DB9M-TERM to provide a DB-9 connection for interfacing to a PC.

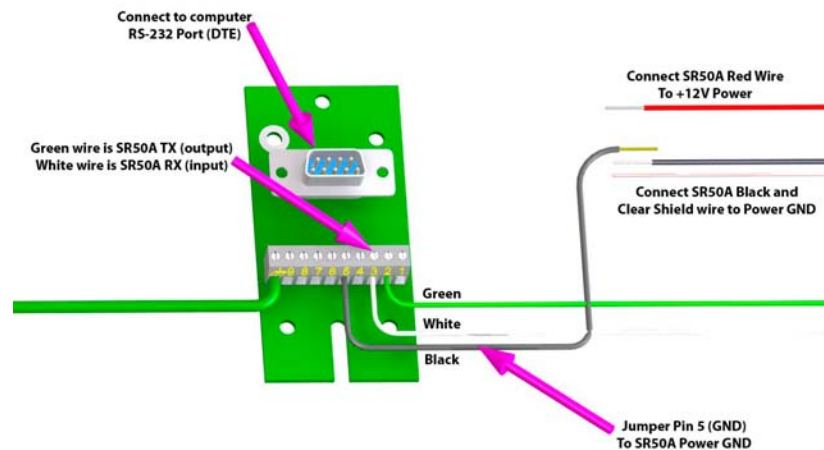

Figure 1 SR50A using a DB9M-TERM

### 3.6 RS-485 Operation

The SR50A sensor comes from the factory with the internal jumpers set to SDI-12 mode. To use the SR50A in the RS-485 mode of operation the jumpers will need to be set as outlined in Section 7.

The RS-485 on the SR50A supports half-duplex communications. This means that the SR50A can receive and transmit but both cannot occur simultaneously. Normally there is a master-slave relationship in most systems to avoid collisions between transmissions. For this reason the Auto Measure Auto Output is not recommended for RS-485 communications. It is much better to have a master initiate the communications by making use of the *Measure On Poll* or the *Auto Measure Polled Output* modes.

Campbell Scientific's MD485 interface can be used to connect one or More SR50A sensors in RS-485 mode to an RS-232 device. This can be useful for sensors that require lead lengths that exceed the limits of either RS-232 or SDI-12 communications.

#### 3.6.1 RS-485 Wiring

The following table/diagram illustrates the wiring for the SR50A in RS-485 mode.

<b>Color</b>	<b>Function</b>	<b>Connection</b>
Black	Power Ground	System Ground and/or RS-232 Receiver Ground (Pin 5 of a computer (DTE) DB-9 connector)
Red	+12VDC Power	Power Source
Green	RS-485 A	To RS-485 A terminal
White	RS-485 B	To RS-485 B terminal
Clear	Shield	Shield/Earth Ground

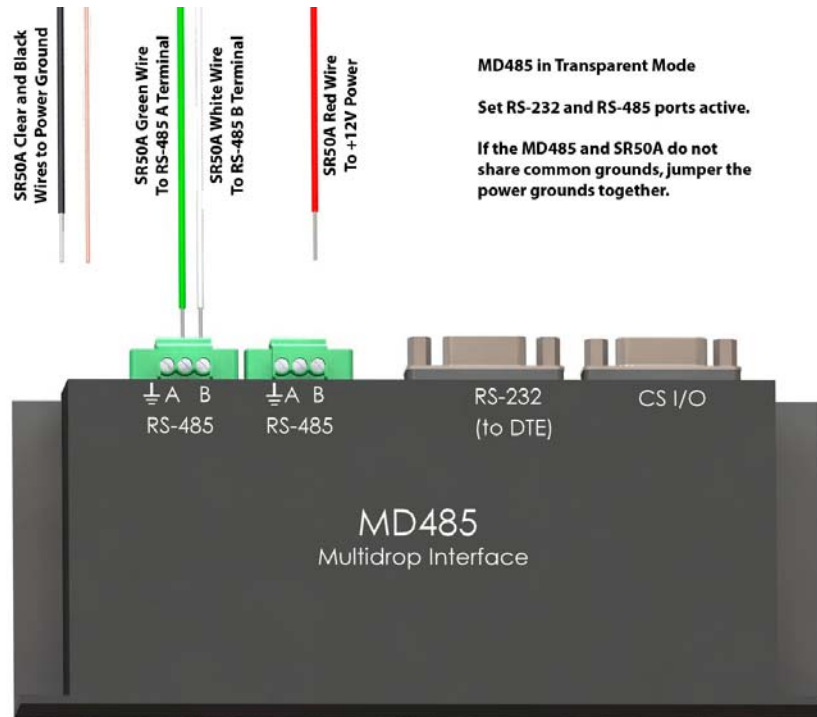

Figure 2 SR50A to MD485 wiring

### 3.7 RS-232 and RS-485 Settings

Once the jumpers are set for RS-232 operation a terminal program such as Hyperterminal can be used to change factory default or existing settings. The following settings apply to Hyperterminal or any other program that is used for communications.

BAUD Rate    Current SR50A Setting<sup>Note</sup>  
Data Bits    8  
Parity        None  
Stop Bits    1  
Flow Control None

**Note** The factory default BAUD rate is 9600 BAUD. Once the BAUD rate is changed the new BAUD rate must be used for further communications to the SR50A. It is important to keep track of the BAUD rate setting on the SR50A. If the BAUD rate setting is unknown, we recommend trying the default value of 9600 BAUD. If that does not work, start at BAUD rate 1200 and go through all the BAUD rate settings until the correct one is found.

When the hyperterminal session is started the command “SETUP” needs to be entered. Hitting the Enter will transmit the CR LF characters which are required after the text “SETUP”. The text “SETUP” is not case sensitive so any combination of upper and lower case letters will work.

The Initial menu will look as follows:

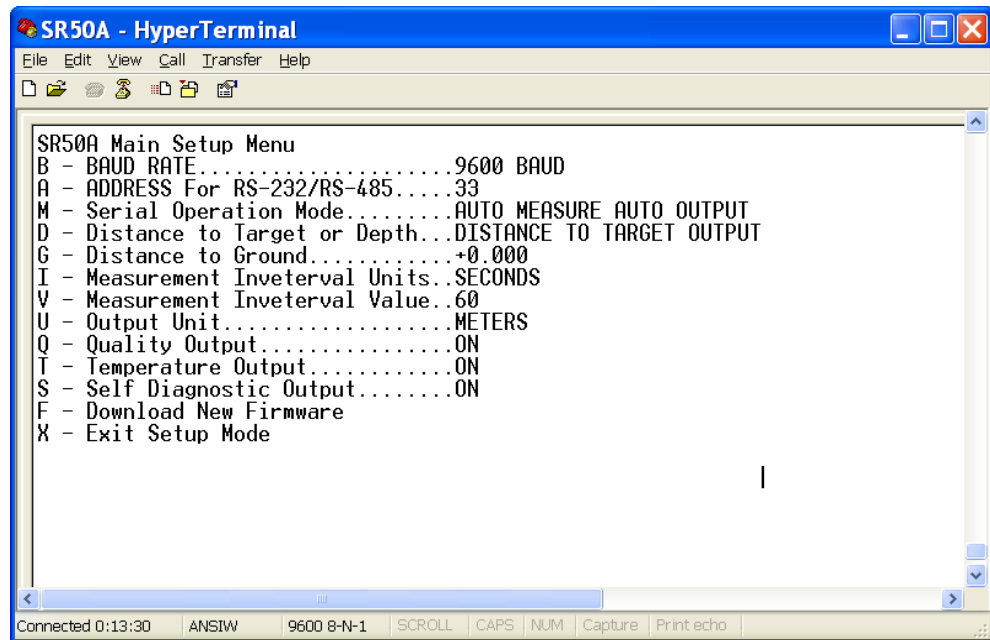

The following is a summary of settings that can be changed on the SR50A RS-232 or RS-485 operating modes.

Setting Description	Options	Default Value
BAUD Rate	1200 4800 9600 19200 38400	9600 BAUD
Address RS-232/RS-485	Any 2 Alphanumeric Characters	33
Serial Operational Mode	Measure on Poll Auto Measure Auto Output Auto Measure Polled Output	Auto Measure Auto Output
Distance to Target or Depth output	Distance to Target Depth	Distance to Target
Distance to Ground	Decimal Value in Meters	0.0
Measurement Interval Units	Seconds Minutes Hours	Seconds
Measurement Interval Value	Integer 1-255	60
Output Unit	Meters Centimeters Millimeters Feet Inches	Meters
Quality Output	On Off	Off
Temperature Output	On Off	Off Output valid only for SR50AT
Diagnostics Output	On Off	Off

### 3.7.1 BAUD Rate Setting

The factory Default BAUD Rate Setting of 9600 BAUD is suitable for most applications. Lower BAUD rates (1200 or 4800) may improve communication reliability or allow for longer cable lengths. Higher BAUD rates (19200 or 38400) may be used where faster communications are required.

The quiescent current draw for the SR50A in serial mode is normally 1.25mA for BAUD rates of 9600 or less. The current draw increases to 1.5 and 2.25 mA for the BAUD rates of 19200 or 38400 respectively.

It is possible to download a firmware update to the SR50A via the RS-232 or RS-485 communication interface. Higher BAUD rates may be desirable to speed up this process.

It may take up to 30 minutes using a speed of 1200 BAUD, 7 minutes using 9600 BAUD, or 3 minutes using 38400 BAUD.

### 3.7.2 Address

The factory Default Address is 33. Normally for RS-232 applications there is no need to change the default address. For RS-485 operation multiple sensors can be polled individually if different addresses are assigned.

### 3.7.3 Operational Mode Setting

There are 3 different operational mode settings available on the SR50A. Overall system design and desired performance determine which mode to select. The SR50A operation for each of the 3 different modes will be described as well as the advantages and disadvantages of each mode.

### 3.7.3.1 Measure in Poll Mode

In this mode the SR50A will remain idle until a measurement command is sent (*p33<CR>*) where 33 is the default serial address. After the measurement command is received, the SR50A will immediately begin a measurement and transmit out the resulting data packet when complete. Typically the SR50A will transmit the data packet within 1 second of receiving the command packet.

- The SR50A only performs a measurement when requested.
- The data output will lag the measurement command by 1 second.
- This configuration is conducive to a multidrop RS-485 system where individual sensors do not transmit data until they are addressed.

### 3.7.3.2 Auto Measure Auto Output Mode

In this mode the SR50A will automatically exit its low power mode, initiate a measurement and output the data. The frequency by which the SR50A will perform this is set by adjusting the *Measurement Interval Units* and the *Measurement Interval Value* parameters.

- No command is required from an external device to obtain a measurement.
- The data recorder or equipment simply needs to read the incoming serial data from the SR50A.

### 3.7.3.3 Auto Measure Polled Output Mode

In this mode the SR50A will automatically exit its low power mode, initiating a measurement. The output data string will not be sent until a poll command is received. When a poll command is received by the SR50A the output data will typically commence 100ms after the poll command is sent.

The frequency by which the SR50A will perform the measurement is set by adjusting the *Measurement Interval Units* and the *Measurement Interval Value* parameters.

- The main advantage of this operating mode is that the receiving device will only have to wait 100ms for the data as opposed to 1 second.
- This configuration is also more conducive to a multidrop RS-485 system where individual sensors do not transmit until they are addressed.

### 3.7.4 Distance to Target or Depth

The SR50A can output either distance to target values or calculate snow depth values. To obtain a valid snow depth value the parameter distance to ground must be entered in.

The SR50AT will compensate the readings for temperature.

Do not use this option on the SR50A sensor unless the SR50A is sent valid temperature reading via the Temperature Input command.

### 3.7.5 Distance to Ground

A valid distance to ground must be entered when the SR50A is configured to output snow depth values. The value must be in Meters regardless of the output units that are selected.

If the exact value cannot be obtained it is better to slightly overestimate the value rather than underestimating it. If a Distance to Ground value is too small, the SR50A will output an error value as the snow surface should not be below the ground surface.

### 3.7.6 Measurement Interval Units

This setting is only applicable if either the *Auto Measure Polled Output* or the *Auto Measure Auto Output* Modes are used. The options for the Measurement Interval Units are:

Seconds  
Minutes  
Hours

Once a unit type is selected the number of units for the interval is set by changing the *Measurement Interval Value* parameter. A 60 second interval can be set by setting the units to seconds and the *Measurement Interval Value* to 60. Alternately, the *Measurement Interval Unit* could be set to Minutes and the Value could be set to 1. The Value setting can only range from 1 to 255.

### 3.7.7 Measurement Interval Value

This setting is only applicable if either the *Auto Measure Polled Output* or the *Auto Measure Auto Output* Modes are used. The *Measurement Interval Value* can range from 1 to 255. The units used for the value is set by the *Measurement Interval Units*.

### 3.7.8 Output Unit

The SR50A always outputs the distance to the target. The units for the distance value can be set to any of the following values:

Meters  
Centimeters  
Millimeters  
Feet  
Inches

### 3.7.9 Quality Output

The SR50A quality numbers can be optionally included in the data output string. The *Quality Output* setting can be set to *ON* or *OFF*.

### 3.7.10 Temperature Output

The SR50AT temperature reading can be optionally included in the data output string. The *Temperature Output* setting can be set to *ON* or *OFF*. This setting should only be enabled for the SR50AT version of the sensor.

### 3.7.11 Diagnostics Output

The SR50A diagnostics numbers can be optionally included in the data output string. The *Diagnostics Output* setting can be set to *ON* or *OFF*.

## 3.8 Serial Commands

### 3.8.1 Setup command

The setup command places the SR50A in the serial setup mode. This command should only be sent to customize a sensor's settings. Upper and lower case letters are accepted and a carriage return character must also terminate the string (Enter key for Hyperterminal).

“setup<CR>”

### 3.8.2 Poll command

The poll command is used to obtain the sensor's output values. The poll command consists of the upper or lower case letter “p” followed by the SR50A address (default 33). The command must also terminate with a carriage return character (Enter for hyperterminal).

“pAA<CR>” – where AA is a two character address and set from the factory to 33

“p33<CR>” – Poll command with factory address of 33

### 3.8.3 Information command

The information command is used to query information from the sensor that is not associated with the sensor's output. For detailed information on the output refer to section 3.9.2.

The information command consists of the upper or lower case letter “i” followed by the SR50A address (default 33). The command must also terminate with a carriage return character (Enter for Hyperterminal).

“iAA<CR>” – where AA is a two character address and set from the factory to 33

“i33<CR>” – information command with factory address of 33

### 3.8.4 Temperature Input command

The temperature input command is used to send the SR50A version of the sensor a temperature value that is to be used for temperature compensation. The value sent must be in degrees Celsius and should not exceed 8 characters.

The command consists of the upper or lower case letter “t” followed by the SR50A address (default 33) a semicolon and the temperature value. The command must also terminate with a carriage return character (Enter for Hyperterminal).

“tAA;-5.5<CR>” – where AA is a two character address and set from the factory to 33 and –5.5 is the temperature in degrees C

“t33;tt.ttt<CR>” – Temperature command with factory address of 33 and a temperature value in Celsius.

## 3.9 RS-232/RS-485 Data Output Format

### 3.9.1 Measurement Output

The measurement output string for the SR50A is as follows:

<STX>aa;D.DDD;QQQ;TT.TT;VVVVV;CC<CR><LF><ETX>

<STX> is the hex character 0x02 (2 in decimal)

aa

These two characters are the serial address of the sensor. The default is 33. Note this is two ASCII characters of 0x33 in Hexidecimal or 51 in decimal.

#### D.DDD

This is the distance to target reading. The units depend on the **Output Units** setting. The number of digits and decimal places do depend on the output unit that is selected. The decimal digits are as follows:

Meters:        D.DDD(One Decimal) 0.000 for no valid reading  
                  DD.DDD possible for values past 9.999 Meters

Centimeters: DDD.DD (2 decimal places)  
                  DDDD.DD possible for values past 999.99 cm  
                  000.00 output for no valid reading

Milimeters:  DDDD (4 digits with no decimal)  
                  -999 output for no valid reading  
                  9999 Maximum value

Feet:        DD.DDD (2 digits with 3 decimal places)  
                  00.000 output for no valid reading

Inches:      DDD.DD (3 digits with Two decimals)  
                  000.00 output for no valid reading

#### QQQ

This data value is the optional quality value output. The quality value is always a 3 digit integer and varies from 162 to 600 (poorest).

#### TT.TT

This is the temperature value in Degrees Celsius read by the SR50AT sensor. This value is optionally output by setting the **Temperature Output** option to **ON**. Only the SR50AT sensor will output a valid temperature. The SR50A will output a – 999.00 if the **Temperature Output** option is set to **ON**. The temperature is displayed with 2 decimal points of precision.

#### VVVVV

This is the diagnostic output value. Each digit represents a pass or a fail on a diagnostic test.

#### XVVVV

If X is a 1, then the ROM Memory has passed the signature test.

VXVVV

If X is a 1, then no watchdog errors have occurred.

VVXXX

The 3 digits XXX are for factory use and should always read 111.

CC

This is a 2 character checksum of the data packet. The checksum is the two's complement of the data packet sum including control characters.

The Least significant byte is used resulting in a 2 character checksum.

<STX> = 0X02 (Hexadecimal)

<CR> = 0X0D (Hexadecimal)

<LF> = 0X0A (Hexadecimal)

<ETX> = 0X03 (Hexadecimal)

The following is a sample packet with proper checksum:

<STX>33;1838;194;11011;2C<CR><LF><ETX>

SUM =

02+33+33+3B+31+38+33+38+3B+31+39+34+3B+31+31+30+31+31

+3B+0D+0A+03

=0x3D4

Use Last byte only (D4) and calculate two's complement

= 100 - D4 = 2C

<CR>

Carriage return character. 0x0d in hexadecimal or 13 in decimal

<LF>

Line feed character. 0x0a in hexadecimal or 10 in decimal

<ETX>

End of transmission character. 0x03 in hexadecimal or 3 in decimal

### 3.9.2 Information Message Output

The measurement output string for the SR50A is as follows:

<STX>aa;SSSSS;H.H;F.F;BBBBB;WWWWW<CR><LF><ETX>

<STX> is the hex character 0x02 (2 in decimal)

aa

These two characters are the serial address of the sensor. The default is 33. Note this is two ASCII characters of 0x33 in Hexidecimal or 51 in decimal.

SSSSS

This is the serial number of the sensor

H.H

This is the hardware version of the sensor

F.F

This is the firmware version of the sensor

BBBBB

This is the checksum of the boot code.

WWWWW

This is the checksum of the firmware.

CC

This is a 2 character checksum of the data packet. The checksum is the two's complement of the data packet sum including control characters.

The least significant byte is used resulting in a 2 character checksum.

<STX> = 0X02 (Hexadecimal)

<CR> = 0X0D (Hexadecimal)

<LF> = 0X0A (Hexadecimal)

<ETX> = 0X03 (Hexadecimal)

The following is a sample packet with proper checksum:

<STX>33;1838;194;11011;2C<CR><LF><ETX>

SUM =

02+33+33+3B+31+38+33+38+3B+31+39+34+3B+31+31+30+31+31

+3B+0D+0A+03

=0x3D4

Use Last byte only (D4) and calculate two's complement =

100 - D4 = 2C

<CR>

Carriage return character. 0x0d in hexadecimal or 13 in decimal

<LF>

Line feed character. 0x0a in hexadecimal or 10 in decimal

<ETX>

End of transmission character. 0x03 in hexadecimal or 3 in decimal

## 4 Sensor Mounting and Installation

### 4.1 Beam Angle

When mounting the SR50A, the sensor's beam angle needs to be considered (see Figure 3 Beam Angle Clearance). It is always best to mount the SR50A perpendicular to the intended target surface. The SR50A has a beam angle of approximately 30 degrees. This means that objects outside this 30 degree beam will not be detected nor interfere with the intended target. Any unwanted target must be outside the 30 degree beam angle.

The following formula is used to determine the required clearance for the beam angle. By inserting a height value in the Formula, a Clearance Radius in the same measurement units as the height can be obtained.

**Clearance Radius formula:**

$$CONE_{radius} = 0.268(CONE_{height})$$

*FORMULA1. Beam angle clearance Radius*

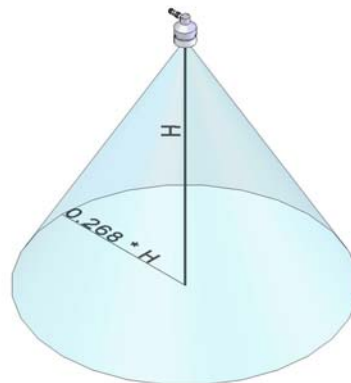

**Figure 3 Beam Angle Clearance**

## 4.2 Mounting Height

Any target to the SR50A should be at least 50cm or more from the face of the transducer. An attempt should also be made to not mount the sensor too far from the target surface. The further the sensor is from the target the more the absolute error increases. If your application is measuring snow depth in an area that will likely not exceed 1.25 meters of snow then a good height to mount the sensor would be 1.75 to 2.0 meters. Mounting the sensor 4 meters above the ground will result in the potential for larger snow depth errors.

### 4.2.1 Reference point

The front grill on the ultrasonic transducer is used for the reference for the distance values. Because it is difficult to measure from the grill one can use the outer edge of the plastic transducer housing see Figure 4. If this edge is used, simply add 8mm to the measured distance.



Figure 4 Distance from edge of transducer housing to grill

## 4.3 Mounting Options

There are two standard mounting options supplied for the SR50A sensor.

The first is the SR50A Mount. This bracket is designed to mount the SR50A parallel or perpendicular to a pipe. Figure 5 demonstrates the parallel mounting method uses 2 band clamps to secure the bracket to the pipe. The minimum pipe diameter is 1.0" (25.4mm) and the maximum diameter is 2.25" (57mm).

Larger band clamps can be used to accommodate larger diameter pipes.

The perpendicular mounting shown in Figure 6 uses a U-bolt to clamp to the pipe. The U-bolt is suitable for pipes ranging from 1" OD to 1-7/8" OD.

Another mounting option show in Figure 7 utilizes a mounting stem (part# C2151) and a Nurail. The mounting stem is sized to fit a 1" Nurail (L1049). This mounting method was used for the SR50 (predecessor to the SR50A ) and the stem can be used to fit the SR50A into existing SR50 mounts.

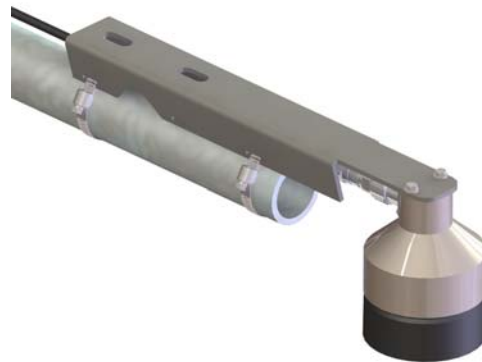

**Figure 5 SR50A Mount (part #C2169) - mounted parallel to pipe**



**Figure 6 SR50A Mount (part #C2169) - mounted perpendicular to pipe**

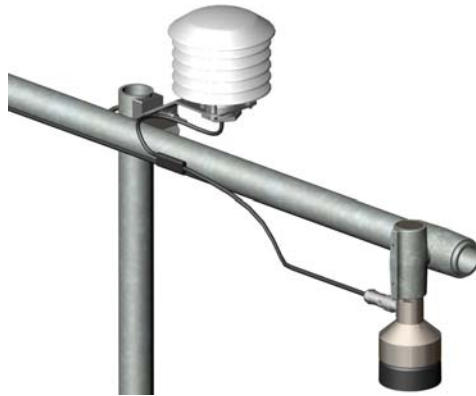

**Figure 7 SR50A - mounted using Nurail and C2151 mounting stem**

***SR50A with 6-plate gill radiation shield – the picture below shows the SR50A stem attachment***



## 5 Maintenance

The SR50A's electrostatic transducer requires equal pressure on both sides. Vent holes in the transducer housing are used to equalize pressure. Desiccant is placed inside the transducer housing to prevent the possibility of condensing humidity. The desiccant must be inspected and, if required, replaced on a regular basis. The desiccant supplied with the SR50A uses an indicating silica gel and will remain blue if it is still capable of absorbing moisture. Once the desiccant becomes saturated the color will change from blue to pink. If the SR50A is used in humid environments, the desiccant should be replaced more frequently. To inspect or replace the desiccant, follow the procedures outlined in Section 7 under disassembly.

The 5 small desiccant packets used in the transducer housing are part number L4091, which are included with C2158 or can be purchased individually or in bulk (DSC 20/M).

It is recommended that the transducer housing assembly (part # C2158 – Transducer Maintenance Kit) be replaced every 3 years.

If the SR50A is used in an environment with high humidity, it is recommended that the transducer housing assembly be replaced every year.

## 6 Disassembly/Assembly Procedures

It is important to follow these instructions to disassemble the SR50A. Disassembly is required to change the transducer and the Option jumpers, and to inspect or replace the desiccant. Before proceeding with any maintenance on a data acquisition system, always retrieve the data first. It is also recommended that the datalogger program be saved.

If the sensor is in operation, always disconnect the SR50A from the datalogger or the connector before disassembling. Refer to Section 3.4.1 or Section 3.5.1, Wiring for further information on your specific wiring connection and disconnection.

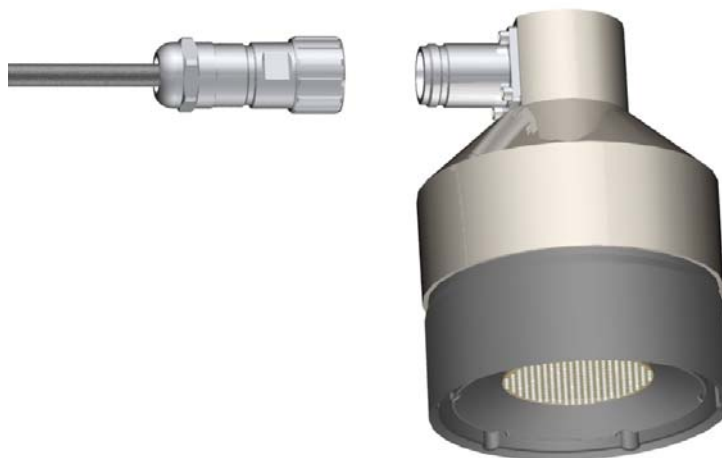

**Figure 8 Disconnect cable from sensor**



**Figure 9 Remove 6 screws from the transducer housing**

**Note:** The screws used on the SR50A have changed from the slotted type to Philips.



**Figure 10 Remove transducer housing and disconnect wires**



**Figure 11 Location of Desiccant in transducer housing assembly**

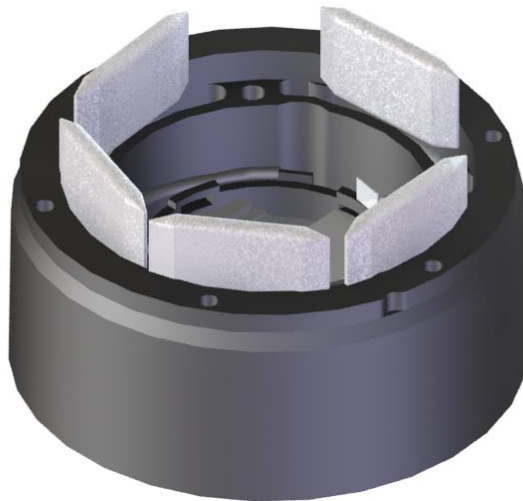

**Figure 12 Remove and Replace Desiccant**

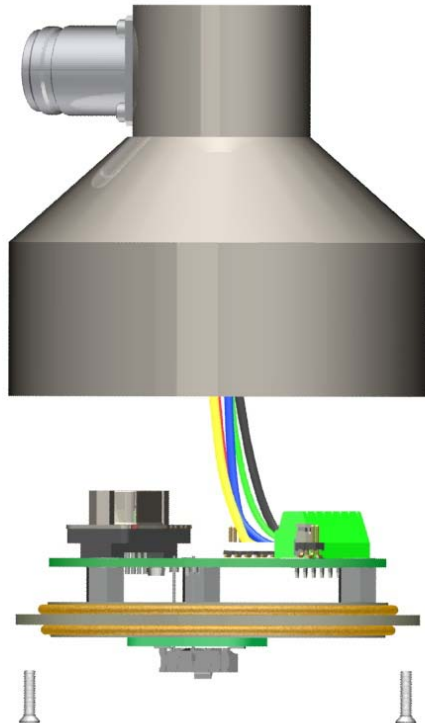
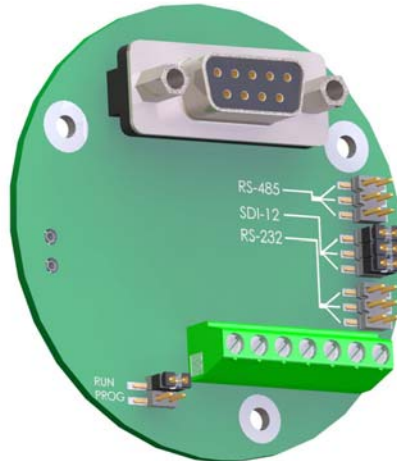

**Figure 13 Remove the 2 flat philips screws to expose the PCB**

Carefully reassemble in reverse order.

## 7 Jumper Settings

The following diagram illustrates how the Jumpers are located on the SR50A sensor.



### **Jumper Settings**

The SR50A can be configured with either SDI-12, RS-232 or RS-485 communications. Shunt jumpers can be located on any of the 3 sets of communication selection headers. All 3 jumpers should be placed only on one group at a time. Never install more than 3 jumpers and never mix the jumpers amongst the SDI-12, RS-232 or RS-485 locations.

The other jumper located on the SR50A places the sensor in either the normal operation mode or in the Program update mode. The program mode is only used for updating the internal firmware of the sensor. For operation the jumper must be left in the RUN position.

Refer to Section 8 for SR50A Firmware Updates.

## 8 SR50A Firmware Updates

The firmware on the SR50A can be updated by using a terminal program such as Hyperterminal. If your SR50A is configured for RS-232 communications, the SR50A can be programmed from the I/O cable. The SR50A also contains an internal female DB-9 connector.

Firmware updates should only be performed at an appropriate workstation with static control procedures in place. Failure to follow the procedures may cause damage to the sensor.

- Ensure that the SR50A is completely disconnected.
- Open the SR50A as follows:
  - Remove the 6 Philips head screws that are located on the bottom side of the transducer housing.  
**Note: The screws used on the SR50A have changed from the slotted type to Philips.**
  - The transducer housing will separate from the main housing.
  - Ensure that the screws and o-rings are kept and set aside.
  - Disconnect the transducer housing assembly from the main body assembly by pressing the tab on the connector and separating the connector.
  - Remove the 2 phillips screws from the bottom disk assembly.
  - The bottom disk assembly should now separate from the main housing.
  - The circuit board will still remain connected to the housing via the signal wires.
  - Place the bottom disk/ circuit assembly on the work bench with the circuit board and DB-9 connector facing up. Ensure that no part of the PCB is in contact with the lid or other conductive objects.
- Move the jumper on the Run/Program Header from the Run position to the Program position.
- Connect to the DB9 connector on the SR50A

- Power can now be applied to the SR50A by connecting the connector and applying power to the sensor. The Green LED should remain on when powered up properly.
- Setup Hyperterminal or the communications program that you are using as follows:
  - BAUD rate: 38400
  - Data Bits: 8
  - Parity: None
  - Stop Bits: 1
  - Flow control: XON/XOFF
  - 25ms line delay (under ASCII setup)
- From the Hyperterminal menu select *Transfer -> Send Text File*
- Select the new download text file and the transfer should begin.
- Initially the LED should remain constantly on. When data transfer begins the LED will flash rapidly with each line that is reprogrammed.
- Upon completion the LED will remain steadily on again. If there are any errors the LED will flash to indicate that an error occurred.
- If the LED does flash attempt the reprogram process again.
- After the reprogramming is successful, disconnect the sensor from the power supply.
- Move the jumper back from the Program position to the Run position.
- Re-assemble the sensor.
- Verify operation of the sensor by obtaining a measurement.

## 9 Data Interpretation

Although not common the SR50A can occasionally output invalid reading indicators if it was unable to obtain a measurement. For distance to target values a 0.0 reading is usually output. For snow depth outputs a -999 is output as an error indicator value. An invalid temperature reading is also indicated by a -999 reading. For snow depth applications these can be easily filtered out when analysing the data.

Consideration should be taken in a control type application to deal with invalid readings. For example if the sensor is used to initiate a water level alarm then multiple readings should be used to ensure that a single invalid reading does not trigger the alarm condition.

## 10 Datalogger Program examples

In the following datalogger program examples only the CR1000 and the CR10X dataloggers are used. The programming of CR800, CR850 and the CR3000 dataloggers are effectively the same as the CR1000. Also for a CR23X datalogger refer to the CR10X programming examples.

### 10.1 Programming Example 1

#### SR50A SDI-12 "M1!" CR10X Datalogger

```

;{CR10X}
;
;In this example, the SR50A is mounted 2.5 meters above the ground.
;The CR10X sends an SDI-12 command to the SR50A, which outputs a
;non-temperature compensated distance value (Raw_Dist) and signal quality value.
;Two input locations are used to store incoming data.

*Table 1 Program
01: 60      Execution Interval (seconds)

;Measure the 107 temperature probe:
1: Temp (107) (P11)
1: 1      Reps
2: 1      SE Channel          ;SE channel 1 used for this example
3: 1      Excite all reps w/E1 ;Excite channel 1 used for this example
4: 1      Loc [ T_Kelvin ]
5: 1.0    Multiplier
6: 273.15 Offset             ;This converts the value to degrees Kelvin

;Use SDI-12 command "M1!" to receive Distance and Signal Quality from the SR50A
2: SDI-12 Recorder (P105)
1: 0      SDI-12 Address
2: 1      Start Measurement (aM1!)
3: 1      Port                ;Use Ports 5-8 for CR23X
4: 3      Loc [ Raw_Dist ]
5: 1.0    Multiplier
6: 0.0    Offset

;Apply air temperature compensation to distance:
3: Z=F x 10^n (P30)
1: 273.15 F
2: 0      n, Exponent of 10
3: 5      Z Loc [ Ref_Temp ]

4: Z=X/Y (P38)
1: 9      X Loc [ T_Kelvin ]
2: 5      Y Loc [ Ref_Temp ]
3: 6      Z Loc [ Mult1 ]

5: Z=SQRT(X) (P39)
1: 6      X Loc [ Mult1 ]
2: 6      Z Loc [ Mult1 ]

```

;Distance to the Snow Surface is obtained by multiplying the temperature correction  
;to the Raw Distance value

6: Z=X\*Y (P36)

1: 3 X Loc [ Raw\_Dist ]

2: 6 Y Loc [ Mult1 ]

3: 7 Z Loc [ DistToSnw ]

;Set the initial distance from the SR50A to the ground in meters:

: Z=F x 10^n (P30)

1: 2.5 F

2: 00 n, Exponent of 10

3: 2 Z Loc [ DisToGnd ]

8: Z=X-Y (P35)

1: 2 X Loc [ DisToGnd ]

2: 7 Y Loc [ DistToSnw ]

3: 8 Z Loc [ SnowDepth ]

;Hourly Data Output

9: If time is (P92)

1: 0 Minutes (Seconds --) into a

2: 60 Interval (same units as above)

3: 1 Set Output Flag High (Flag 0)

10: Set Active Storage Area (P80)

1: 1 Final Storage Area 1

2: 60 Array ID

11: Real Time (P77)

1: 1220 Year,Day,Hour/Minute (midnight = 2400)

12: Sample (P70)

1: 1 Reps

2: 8 Loc [ SnowDepth ]

;The SR50A signal quality value can optionally be stored as well

13: Sample (P70)

1: 1 Reps

2: 4 Loc [ Sig\_Qual ]

\*Table 2 Program

02: 0.0000 Execution Interval (seconds)

\*Table 3 Subroutines

End Program

## 10.2 Programming Example 2

### SR50AT SDI-12 "M3!" CR10X Datalogger

```

;{CR10X}
;
;In this example, the SR50AT is mounted 2.5 meters above the ground.
;
;The CR10X sends an SDI-12 command to the SR50AT, which outputs the
;temperature compensated distance value (Meters),
;the signal quality value and the temperature.
;
;Three input locations are used to store incoming data.

*Table 1 Program
01: 60      Execution Interval (seconds)

;Use SDI-12 command "M3!" to receive Distance, Signal Quality and Temperature
1: SDI-12 Recorder (P105)
1: 0      SDI-12 Address
2: 3      Start Measurement (aM3!)
3: 1      Port          ;Use Ports 5-8 for CR23X
4: 3      Loc [ SR50ATDIS ]
5: 1.0    Multiplier
6: 0.0    Offset

;Set the initial distance from the SR50A to the ground in meters:
2: Z=F x 10^n (P30)
1: 2.5    F
2: 00     n, Exponent of 10
3: 2      Z Loc [ DisToGnd ]

;Subtract the Distance to the snow surface from the Distance to Ground
;to obtain snow depth
3: Z=X-Y (P35)
1: 2      X Loc [ DisToGnd ]
2: 3      Y Loc [ SR50ATDIS ]
3: 6      Z Loc [ SnowDepth ]

;Hourly Data Output
4: If time is (P92)
1: 0      Minutes (Seconds --) into a
2: 60     Interval (same units as above)
3: 10     Set Output Flag High (Flag 0)

5: Set Active Storage Area (P80)
1: 1      Final Storage Area 1
2: 60     Array ID

6: Real Time (P77)
1: 1220   Year,Day,Hour/Minute (midnight = 2400)

7: Sample (P70)
1: 1      Reps
2: 6      Loc [ SnowDepth ]

```

```
;Store the Signal quality value
8: Sample (P70)
1: 1    Reps
2: 4    Loc [ Sig_Qual ]

;Store the Temperature reading from the SR50AT
9: Sample (P70)
1: 1    Reps
2: 5    Loc [ SR50AT_T ]

*Table 2 Program
02: 0.0000 Execution Interval (seconds)

*Table 3 Subroutines

End Program
```

### 10.3 Programming Example 3

#### SR50A SDI-12 "M1!" CR1000 Datalogger

'CR1000 Series Datalogger

'In this example, the SR50A is mounted 2.5 meters above the ground.

'The CR1000 sends an 'SDI12 command to the SR50A,  
'which outputs a raw distance value and a signal quality.

'Declare Public Variables:

Public SR50(2)

Alias SR50(1)=Raw\_Dist

Alias SR50(2)=SignalQuality

Public Temp\_Corr\_Distance

Public Air\_Temp

Public Snow\_Depth

'Declare the initial distance of the SR50A from the ground in meters:

Const Initial\_Distance = 2.5

'Define Data Tables:

DataTable (Table1,True,-1)

    DataInterval (0,60,Min,10)

    Sample (1,Snow\_Depth,FP2)

EndTable

'Main Program:

BeginProg

    Scan (60,Sec,0,0)

        'Measure the SR50A:

        'Use SDI12 command "M1!" to receive Distance

        'and Signal quality from the SR50A

        SDI12Recorder (SR50(),1,0,"M1!",1,0)

        'Measure the 107 temperature sensor:

        Therm107 (Air\_Temp,1,1,Vx1,0,250,1.0,0)

        'Use Air\_Temp to calculate corrected distance:

        Temp\_Corr\_Distance=Raw\_Dist\*(SQR((Air\_Temp+273.15)/273.15))

        'Subtract the corrected distance from the initial distance of the SR50A to the ground:

        Snow\_Depth=Initial\_Distance-Temp\_Corr\_Distance

        'Call Data Table and Store Data:

        CallTable (Table1)

    NextScan

EndProg

## 10.4 Programming Example 4

### SR50AT SDI-12 “M4!” Snow Depth Output CR1000

```

'CR1000 Series Datalogger
'The following sample program obtains the Snow depth output
'directly from an SR50AT sensor.
'This program is written for the SR50AT version only. For an SR50A
'sensor a valid depth can not be output unless a temperature value
'is passed from the datalogger to the SR50A via the extended SDI-12 command

'Declare Public Variables
Public PTemp, batt_volt

Public SR50ADistanceToGround

'Once the SR50AT is installed the Distance from the SR50AT to the
'Ground must be placed into this parameter. Once successfully transferred
'to the SR50AT the SR50AT will store the parameter in EE memory and retain
'the value even when power is removed.
Public NewDistanceToGround

Public SR50AReturnValues(3) as FLOAT

Public XtendedDistValStr as STRING * 16

Public ExtendedCMDResult as FLOAT

Alias SR50AReturnValues(1) = SR50A_SnowDepth_Meters
Alias SR50AReturnValues(2) = SR50A_QualityVal
Alias SR50AReturnValues(3) = SR50A_AirTempC

'Declare Other Variables
'Example:
'Dim Counter
Dim SDI12commandstring as STRING * 16

'Declare Constants
'Example:
'CONST PI = 3.141592654

'Define Data Tables
DataTable (Test,1,-1)
  DataInterval (0,60,Sec,10)
  Minimum (1,batt_volt,FP2,0,False)
  Sample (1,PTemp,FP2)
  Sample (1,SR50A_SnowDepth_Meters,IEEE4)
  Sample (1,SR50A_QualityVal,FP2)
  Sample (1,SR50A_AirTempC,IEEE4)

EndTable

'Main Program

```

BeginProg

Scan (60,Sec,0,0)

PanelTemp (PTemp,250)

Battery (Batt\_volt)

*'Once installed enter the actual distance from the SR50AT to the Ground with  
'no snow present. If in doubt it is better to use a slightly larger value  
'than a smaller value. Errors in the value will show up as an offset error  
'in the snow depth values*

*'If a new value for the variable NewDistanceToGround is entered (non zero)  
'The following code will send that value to the SR50AT.*

If NewDistanceToGround > 0.0 then

*'Convert the floating point value to a text string for the SDI-12 command*  
XtendedDistValStr = FormatFloat (NewDistanceToGround,"%4.3f")

*'To send the Distance to ground (in meters) value to the SR50A the  
'SDI-12 extended command is as follows:*

*'aXDM.MMM!- where M.MMM is the value such as 2.345 Meters*

SDI12commandstring = "XM;" + XtendedDistValStr + "!"

*'Send out the SDI-12 command to the sensor*

SDI12Recorder (ExtendedCMDResult,1,0,SDI12commandstring,1.0,0)

*'Read back the Distance to Ground value in the SR50A to confirm*

SDI12Recorder (SR50ADistanceToGround,1,0,"R0!",1.0,0)

*'If the Sensor is present confirm the value was sent correctly*

*'Never use more than 3 decimal places of precision for the new value*

If ExtendedCMDResult = 1.0 then

*'Reset the value so that no more attempts will be made to update the  
'Distance to Ground value.*

NewDistanceToGround = 0.0

*'Read back the Distance to Ground value from the SR50A to confirm.*

*'This is not necessary but recommended.*

SDI12Recorder (SR50ADistanceToGround,1,0,"R0!",1.0,0)

EndIf

EndIf

*'Read the Snow depth from the SR50A "M4!" command returns depth with  
'quality and temperature*

SDI12Recorder (SR50AReturnValues,1,0,"M4!",1.0,0)

*'Call Output Tables*

*'Example:*

CallTable Test

NextScan

EndProg

## 10.5 Programming Example 5

### SR50A RS-232 Mode CR1000

```
'CR1000 Series Datalogger

'In this example, the SR50A is mounted 2.5 meters above the ground.
'The SR50A is used in RS-232 mode (internal jumpers are set).
'The CR1000 sends a serial string to the SR50A, which is in "Measure on Poll Mode",
'and then receives a serial string in return which is parsed into different values.

'Wiring:  Black: Power Ground
'          clear: Power Ground
'          Red:  +12V,
'          White:C1
'          Green:  C2

'Declare Variables
'Declare SR50AData as a dimensioned string of maximum 50 chrs
Dim SR50AData as STRING * 50

Public ParseVals(5) as FLOAT

Alias ParseVals(1)=SerialAddress
Alias ParseVals(2)=Raw_Distance
Alias ParseVals(3)=SignalQuality
Alias ParseVals(4)=Diagnostics
Alias ParseVals(5)=Chcksum

Public Temp_Corr_Distance
Public Air_Temp
Public Snow_Depth

'Declare the initial distance of the SR50A from the ground in meters:
Const Initial_Distance=2.5

'Define Data Tables
DataTable (Table1,True,-1)
  DataInterval (0,60,Min,10)
  Sample (1,Snow_Depth,FP2)
EndTable

'Main Program
BeginProg
'Open RS232 port for communications 9600 BAUD is the default:
SerialOpen (Com1,9600,0,0,2000)

Scan (60,Sec,0,0)
'Measure the SR50A:
'Transmit serial command "p33<CR>"
SerialOut (Com1,"p33"+chr(13),"",0,0)
```

```
'Flush the serial buffer
SerialFlush (Com1)

'Recieve serial string from SR50A
SerialIn (SR50AData,Com1,200,13,50)
SplitStr (ParseVals,SR50AData,"",5,0)

'Measure the 107 temperature sensor:
Therm107 (Air_Temp,1,1,Vx1,0,250,1.0,0)

'Use Air_Temp to calculate corrected distance:
Temp_Corr_Distance=Raw_Distance*(SQR((Air_Temp+273.15)/273.15))

'Subtract the corrected distance from the initial distance of the SR50A to the ground:
Snow_Depth=Initial_Distance - Temp_Corr_Distance

'Call Data Table and Store Data:
CallTable (Table1)
NextScan
EndProg
```

## 10.6 Programming Example 6

### SR50AT RS-232 Mode CR1000

```
'CR1000 Series Datalogger

'In this example, the SR50AT is mounted 2.5 meters above the ground.
'The SR50AT is used in RS-232 mode (internal jumpers are set).
'The CR1000 sends a serial string to the SR50AT, which is in "Measure on Poll Mode",
'and then receives a serial string in return which is parsed into different values.

'Wiring:  Black: Power Ground
'          clear: Power Ground
'          Red: +12V,
'          White:C1
'          Green: C2

'Declare Variables
'Declare SR50AData as a dimensioned string of maximum 50 chrs
Dim SR50AData as STRING * 50

Public ParseVals(6) as FLOAT

Alias ParseVals(1)=SerialAddress
Alias ParseVals(2)=Dist_To_Snow
Alias ParseVals(3)=SignalQuality
Alias ParseVals(4)=SR50AT_Temp
Alias ParseVals(5)=Diagnostics
Alias ParseVals(6)=Chcksum

Public Snow_Depth

'Declare the initial distance of the SR50AT from the ground in meters:
Const Initial_Distance=2.5

'Define Data Tables
DataTable (Table1,True,-1)
  DataInterval (0,60,Min,10)
  Sample (1,Snow_Depth,FP2)
EndTable

'Main Program
BeginProg
'Open RS232 port for communications 9600 BAUD is the default:
SerialOpen (Com1,9600,0,0,2000)

Scan (10,Sec,0,0)
'Measure the SR50A:
'Transmit serial command "p33<CR>"
SerialOut (Com1,"p33"+chr(13),"",0,0)

'Flush the serial buffer
SerialFlush (Com1)

'Recieve serial string from SR50A
```

```
SerialIn (SR50AData,Com1,200,13,50)
```

```
SplitStr (ParseVals,SR50AData,"",6,0)
```

```
'Subtract the corrected distance from the initial distance of the SR50A to the ground:
```

```
Snow_Depth=Initial_Distance - Dist_To_Snow
```

```
'Call Data Table and Store Data:
```

```
CallTable (Table1)
```

```
NextScan
```

```
EndProg
```

## **11 Warnings/Cautions**

Never open the SR50A while the sensor is connected to power or any other device. Always disconnect the SR50A via the connector or disconnect the cable wires from their termination points.

## APPENDIX A

### SR50AH Heater Option

#### 1 Heater Introduction

The heater option on the SR50AH is intended for installations where rime ice is problematic. The heater will help to prevent the ice from forming on the transducer, which can impair proper operation of the sensor.

The heater option is easily identifiable as the transducer housing contains a cable port for the heater supply cable.

For battery operated solar powered sites it is recommended that the power to the heater be turned off when icing conditions are not occurring to reduce power requirements. The heater power must be turned off when operating at temperatures of 25°C or more.

#### 2 Specifications

Heater Resistance:	75 Ohms
Nominal Operating Voltage	12 Volts (AC or DC) <sup>Note1</sup>
Maximum Rated Wattage:	3 Watts
Maximum Rated Voltage:	15 Volts (AC or DC)
Maximum Operating Temperature:	25°C <sup>Note2</sup>

##### 2.1 Heating Cable Requirements

Type:	2 conductor (twisted pair), Shielded
Diameter:	4-6mm (0.16 - 0.24 inches)
Recommended Gauge:	22 AWG for Lengths Less than 30 Meters (100 feet)

Note 1: It is important to use a properly conditioned low noise power source. A noisy power source will affect operation of the sensor.

Note 2: It is recommended that some form of control be used to turn the heater power off at warmer temperatures. Damage to the sensor may result from operation at elevated temperatures.



**Figure 14 SR50AH Heater option**

### **3 Maintenance**

The same maintenance procedures apply to the SR50AH as the regular SR50A sensor. Please refer to the SR50A manual for maintenance information.

The transducer and desiccant replacement is slightly different for the SR50AH as it is for the SR50A. When ordering replacement transducers ensure that the SR50AH part# C2370 is ordered.

The procedure to disassemble the SR50AH for desiccant replacement or transducer replacement is as follows:

1. Remove the 6 Philips screws on the outermost hole pattern.  
**Note: The screws used on the SR50A have changed from the slotted type to Philips.**

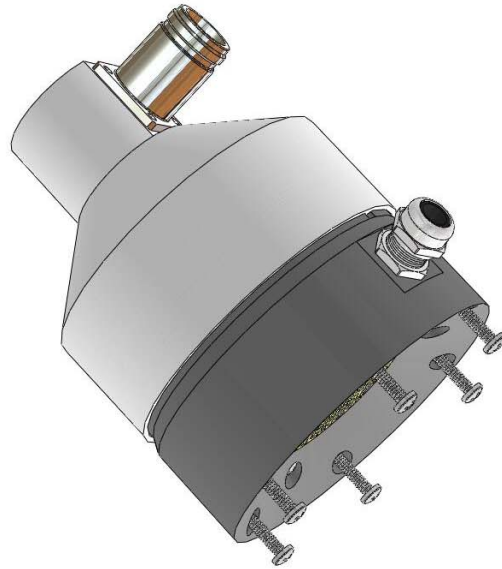

2. Separate the housing from the sensor body and disconnect the connector from the transducer to the main sensor body.

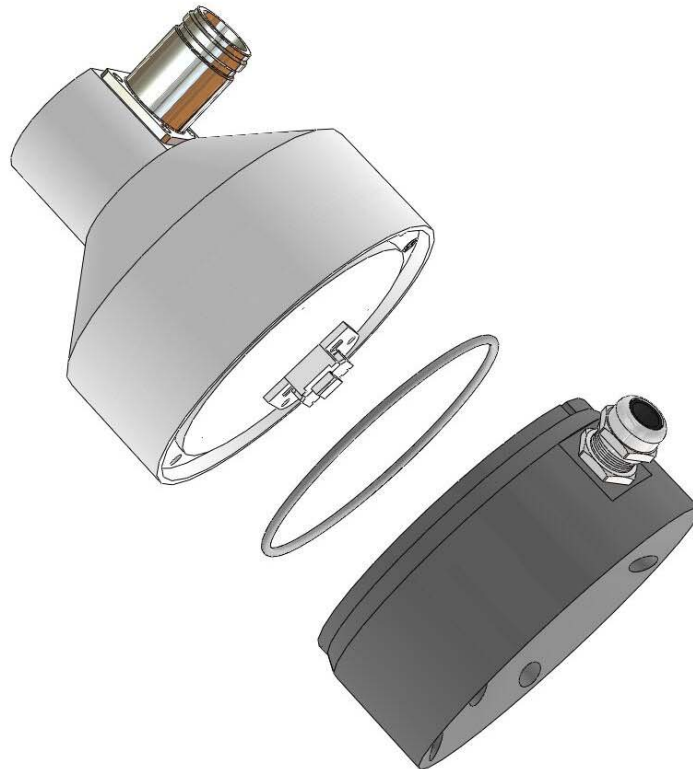

3. To replace the desiccant remove the desiccant holder plate with the Philips 4-40 screw. Cutting the tie strap and will allow the old packets to be removed for replacement. During reassembly ensure that the desiccant does not come in contact with the metal backing

of the transducer. If only the desiccant is being inspected or replaced, step 4 and 5 are not required. Steps 4 to 6 are required to replace the transducer only.

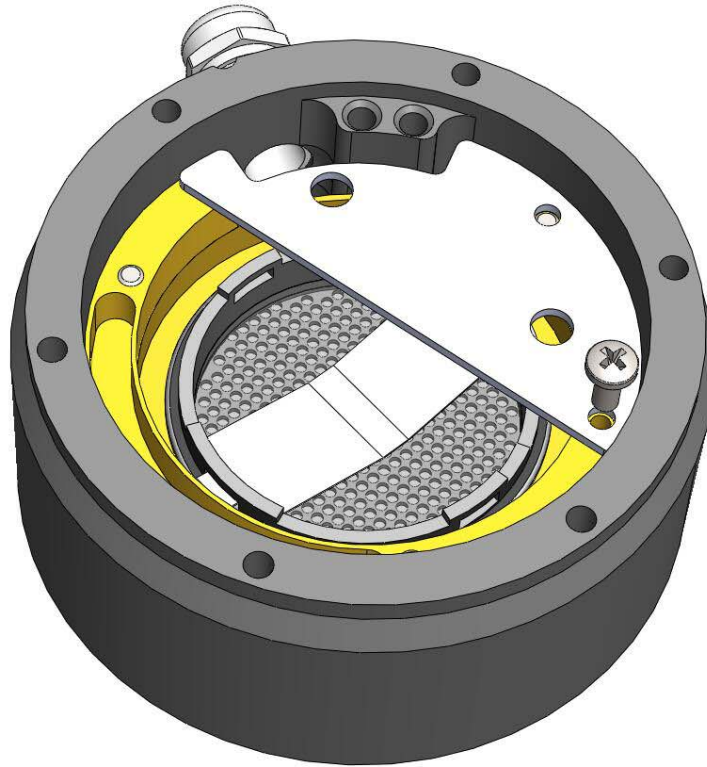

4. Your transducer kit comes with a replacement for the o-ring that seats between the main sensor body and the plastic transducer housing. Ensure that the new o-ring is used when reassembled.
  
5. Remove the 3 screws from the innermost hole pattern as shown.

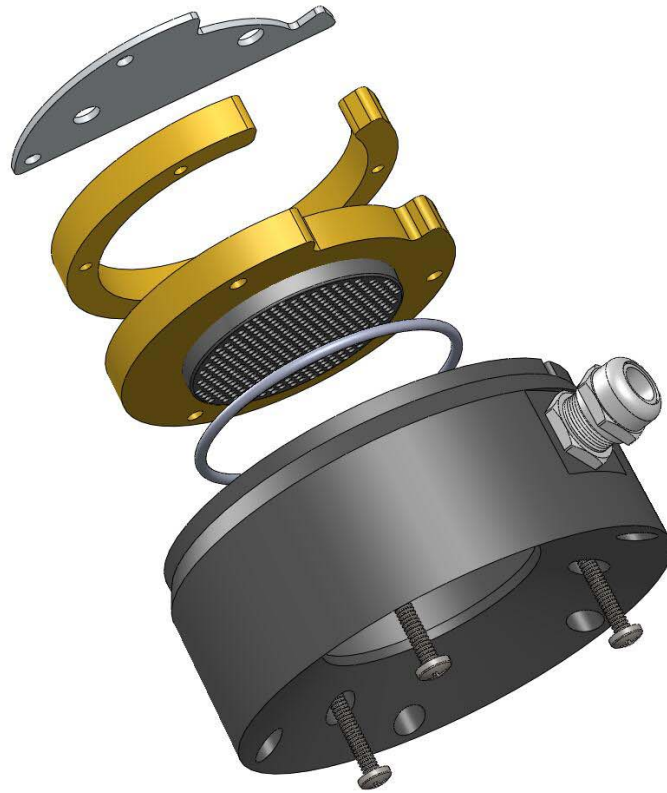

6. Replace the transducer assembly and the second o-ring that seats under the transducer assembly.
7. Reassemble the sensor in the reverse order. Please observe the orientation of the parts, wiring and desiccant.



**Figure 15 Complete transducer assembly with power connection**

## Appendix B

### Optional Open Faced Transducer for Harsh Environments

#### 1 General



*Part # C2257 – Open Faced Transducer*

The Open Faced transducer provides extra corrosion protection (from various chemicals) to the gold coating of the foil.

The outer face of the transducer is coated with parylene which will help prevent the gold from being chemically attacked. The wire mesh is removed from this transducer to counter the decrease in sensitivity due to the coating.

The open faced transducer will help to extend the transducer replacement interval in some environments. Regular desiccant replacement is still necessary with this transducer as well.

## **Appendix C**

### **SR50A-316SS and SR50AT-316SS Options**

#### **1 Introduction**

The 316 Stainless Steel option is recommended for installations where corrosion is problematic. This is typically a marine environment, but it is not limited to this environment. The Stainless Steel option will help prevent damage to the chassis of the sensor.

Two model options are available, either the SR50A-316SS or the SR50AT-316SS. Both models are identical in operational aspects to their aluminum chassis equivalent.