

INSTRUCTION MANUAL



SP Lite2 Silicon Pyranometer

March 2010



*Copyright © 2010
Campbell Scientific (Canada) Corp.*

WARRANTY AND ASSISTANCE

This equipment is warranted by CAMPBELL SCIENTIFIC (CANADA) CORP. ("CSC") to be free from defects in materials and workmanship under normal use and service for **twelve (12) months** from date of shipment unless specified otherwise. ***** **Batteries are not warranted.** ***** CSC's obligation under this warranty is limited to repairing or replacing (at CSC's option) defective products. The customer shall assume all costs of removing, reinstalling, and shipping defective products to CSC. CSC will return such products by surface carrier prepaid. This warranty shall not apply to any CSC products which have been subjected to modification, misuse, neglect, accidents of nature, or shipping damage. This warranty is in lieu of all other warranties, expressed or implied, including warranties of merchantability or fitness for a particular purpose. CSC is not liable for special, indirect, incidental, or consequential damages.

Products may not be returned without prior authorization. To obtain a Return Merchandise Authorization (RMA), contact CAMPBELL SCIENTIFIC (CANADA) CORP., at (780) 454-2505. An RMA number will be issued in order to facilitate Repair Personnel in identifying an instrument upon arrival. Please write this number clearly on the outside of the shipping container. Include description of symptoms and all pertinent details.

CAMPBELL SCIENTIFIC (CANADA) CORP. does not accept collect calls.

Non-warranty products returned for repair should be accompanied by a purchase order to cover repair costs.



CAMPBELL SCIENTIFIC
C A N A D A C O R P .

11564 - 149 street - edmonton - alberta - T5M 1W7
tel 780.454.2505 fax 780.454.2655

www.campbellsci.ca

SP Lite2 Silicon Pyranometer

Table of Contents

1. General Description	1
1.1 Electrical Properties	1
1.2 Spectral Properties	2
1.3 Directional/Cosine Response	3
2. Sensor Specifications	4
3. Installing the SP Lite2	5
4. Wiring	6
5. Datalogger Programming	6
5.1 Datalogger Input Range Codes	7
5.2 Calibration Factor and Multiplier	7
5.3 Program Examples for Average Solar Radiation	7
5.4 Program Examples for Total Solar Radiation	9
5.4.1 Output Format Considerations	9
6. Maintenance	12
6.1 Calibration	12
7. Troubleshooting	12
7.1 Pyranometer produces no apparent output.....	12
7.2 Readings are not as expected	12

SP Lite2 Silicon Pyranometer

The SP Lite2 measures incoming solar radiation (sun plus sky radiation) with a photodiode detector. Output from the photodiode is a current, which is converted to voltage by an internal shunt resistor. The SP Lite2 can be used in solar energy applications such as plant growth, thermal convection and evapotranspiration.

1. General Description



FIGURE 1. SP Lite2 Sensor with Leveling Instrument

The SP Lite2 is used for measuring solar radiation. It measures the solar energy received from the entire hemisphere – i.e. 180° field of view. The output is expressed in Watts per square meter ($W m^{-2}$).

The SP Lite2 is designed for continuous outside use, and its calibration is valid only for unshaded natural daylight – not for artificial light. It is most usually used to measure solar radiation being received on the horizontal plane. However, the SP Lite2 can, if required, be used in an inverted or tilted position.

1.1 Electrical Properties

The SP Lite2 consists of a photodiode complete with housing and cable. The circuit includes a shunt resistor for the photodiode in order to generate a voltage output. The electrical specification of the sensor is determined by the characteristics of the photodiode and resistor. The electrical circuit of the pyranometer is shown in Figure 2, below.

The electrical sensitivity of the photodiode changes with temperature. A nominal value for this change is 0.15% change per °C. Calibration is carried out at 20 °C.

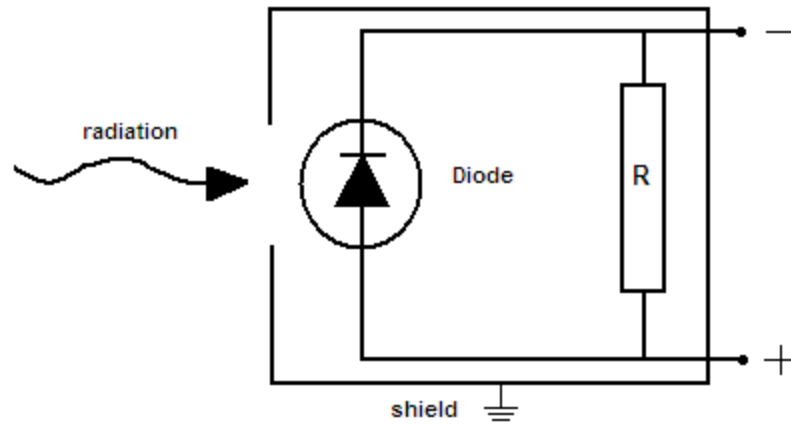

FIGURE 2. SP Lite2 Electrical Circuit

1.2 Spectral Properties

The spectral properties of the SP Lite2 are mainly determined by the spectral response of the photodiode, which is shown in Figure 3, below.

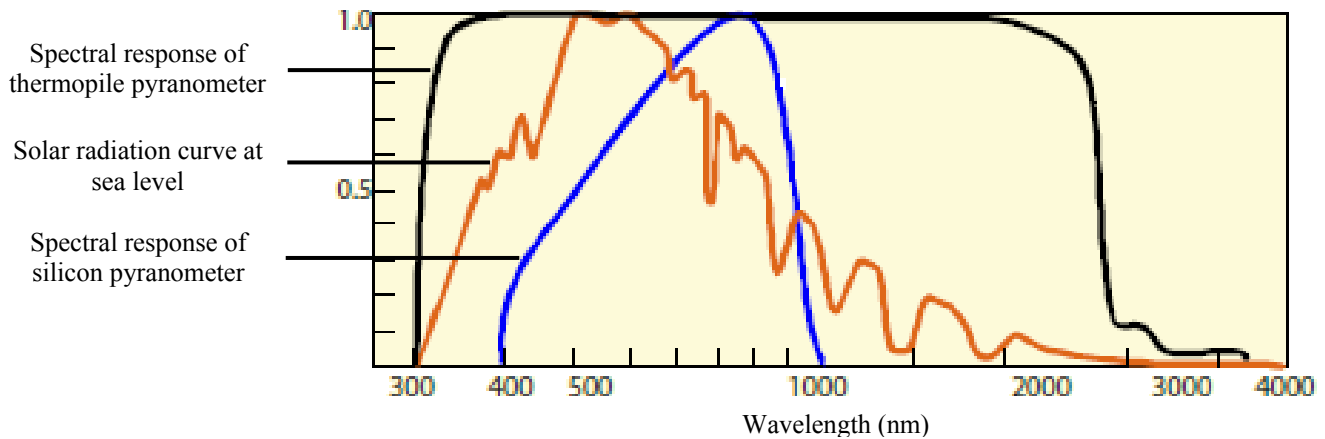

FIGURE 3. Spectral Sensitivity of Pyranometers Compared with Solar Radiation

The SP Lite2 is calibrated for solar radiation under clear sky conditions. The spectrum for these conditions, at sea level, is also shown in Figure 3.

Unfortunately, however, the actual solar spectrum varies as a function of cloud cover, season and solar elevation. Since the pyranometer does not have a flat sensitivity across the whole solar spectrum, the accuracy of its response will vary. However, the error range across the whole spectrum has been proven to be small. The maximum total estimated error will only be in the region of $\pm 5\%$ when compared to the calibration conditions.

Both the spectral sensitivity and the photodiode sensitivity of the SP Lite2 will change with temperature, and the separate effect of each of these changes cannot be easily determined.

1.3 Directional/Cosine Response

A perfect cosine response will show maximum sensitivity at an angle of incidence of zero degrees (perpendicular to the sensor surface) and zero sensitivity at an angle of incidence of 90 degrees (radiation passing over the sensor surface). At any angle between 0 and 90 degrees the sensitivity should be proportional to the cosine of the angle of incidence.

Figure 4 shows the behavior of a typical SP Lite2. The vertical axis shows the deviation from ideal behavior, expressed in percentage deviation from the ideal value.

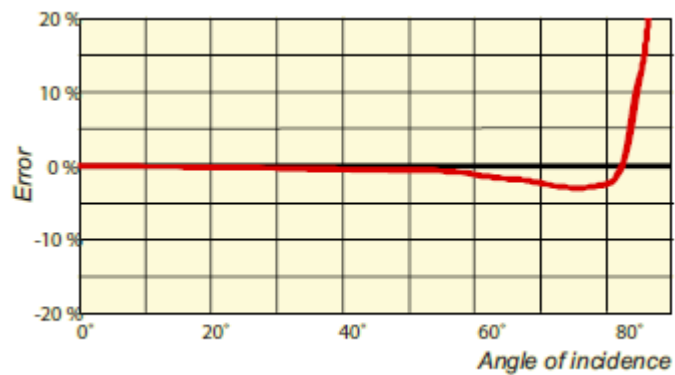

FIGURE 4. Cosine Response of a Typical SP Lite2 Pyranometer

In Figure 4, 0 degrees zenith angle equals 90 degrees angle of incidence. The vertical axis shows the percentage deviation from ideal cosine behavior.

2. Sensor Specifications

Electrical

Nominal Impedance:	> 1 M Ω
Response Time:	<1 second (at 95%)
Sensitivity:	(see Certificate of Calibration that was shipped with sensor)
Expected signal range: (under atmospheric conditions)	0 – 120 mV
Sensitivity:	< \pm 2% shift per year
Non-linearity:	< \pm 1% between 0 to 1000 W m ⁻²
Temperature dependence of sensitivity:	< \pm 0.15% / $^{\circ}$ C

Spectral

Spectral range:	400 to 1100 nm
Detector type:	BPW 34

Directional

Cosine corrected between 80 $^{\circ}$ angle of incidence, error:	within \pm 5%
Cosine errors averaged over opposite azimuth error (at 60 $^{\circ}$ angle of incidence):	within \pm 5%
Tilt response:	zero error

Mechanical

Housing material:	Anodized aluminum
Cable material:	Polyurethane
Weight:	110 g
Cable length:	5 m (can be extended up to 100 m)
Physical Dimensions:	See Figure 5

Environmental

Working temperature:	-30 to +70 $^{\circ}$ C
----------------------	-------------------------

Dimensions

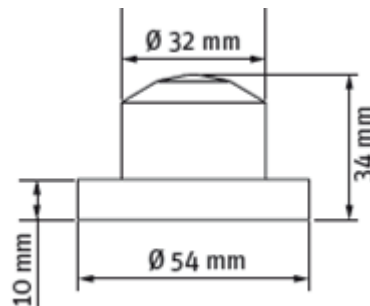

FIGURE 5. Dimensions of SP Lite2 with Leveling Device

3. Installing the SP Lite2

The SP Lite2 with leveling instrument are attached to a tripod or tower using one of two mounting configurations (see Figures 6).

Mount the sensor on the mounting arm so that no shadow will be cast on it at any time of day, at any time of year, from obstructions such as trees, buildings or the mast or structure on which it is mounted. In the northern hemisphere the instrument is normally oriented towards the South to avoid potential problems from shading.

NOTE

The SP Lite2 will only perform to specification under clear-sky conditions. It must not be mounted where it is subject to shade, beneath structures or beneath a plant canopy.

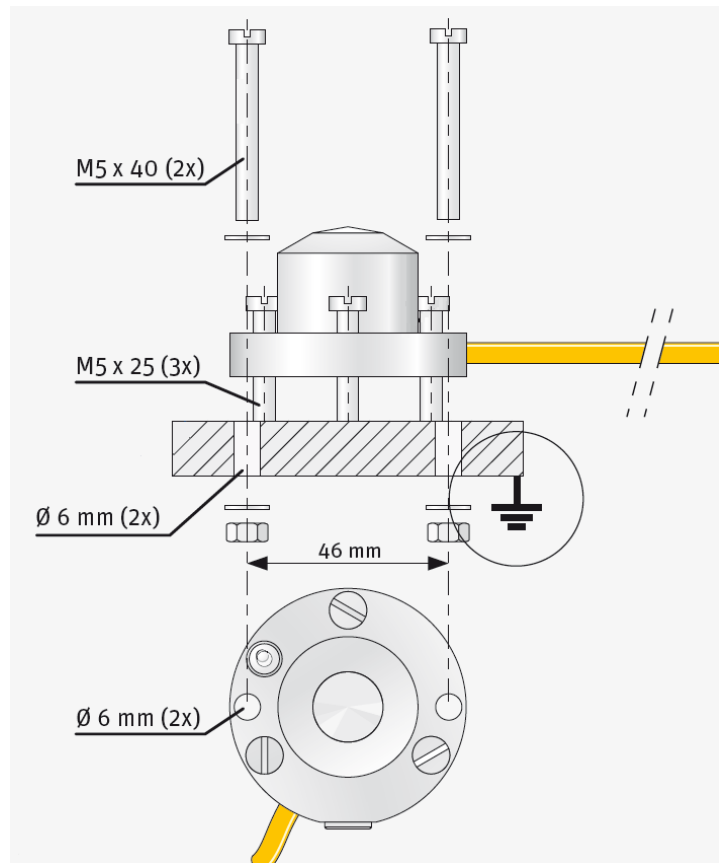

FIGURE 6: SP Lite2 Mounting Configuration

Mount the sensor on the mounting arm at a height of at least 1.5 m above the ground surface to minimize shading effects. The SP Lite2 has a built-in bubble level should be used to level the SP Lite2 once mounted to the 015 ARM. Mount and adjust the SP Lite2 as follows:

1. Attach the mounting arm to the tripod or tower at the required height.
2. Loosely attach the SP Lite2 to the mounting arm using the two bolts (M5 x 40), washers and nuts. Mounting screws are provided with the SP Lite2.
3. Thread the three M5 x 25 leveling bolts into the base of the SP Lite2. Adjust the three leveling bolts as required to center the bubble in the level. Tighten the two mounting bolts.

4. Wiring

The SP Lite2 can be measured with a differential or single-ended channel on the datalogger; a differential channel is recommended and does require a user supplied jumper between the signal reference wire and a ground terminal. Please review Tables 1 & 2 for sensor wiring.

TABLE 1. Datalogger Connections for Differential Measurement					
Function	Colour	CR800, CR1000, CR3000	CR10X, CR510	CR23X	21X/CR7
Radiation Signal	Red	Differential H	Differential H	Differential H	Differential H
Signal Reference	Blue	Differential L	Differential L	Differential L	Differential L
	Jumper to	⊕	AG	⊕	⊕
Shield	Black	G	G	⊕	⊕

TABLE 2. Datalogger Connections for Single-Ended Measurement					
Function	Colour	CR800, CR1000, CR3000	CR10X, CR510	CR23X	21X/CR7
Radiation Signal	Red	S.E. Channel	S.E. Channel	S.E. Channel	S.E. Channel
Signal Reference	Blue	⊕	AG	⊕	⊕
Shield	Black	G	G	⊕	⊕

5. Datalogger Programming

The SP Lite2 outputs a low-level voltage ranging from 0 to a maximum of about 120mV. A differential voltage measurement (VoltDiff, or Instruction 2) is recommended because it has better noise rejection than a single-ended measurement. If a differential channel is not available, a single-ended measurement (VoltSE, or Instruction 1) can be used. The acceptability of a single-ended measurement can be determined by simply comparing the results of single-ended and differential measurements made under the same conditions.

5.1 Datalogger Input Range Codes

Normally the 500 mV range for the 21X and CR7, the 250 mV range for the CR800, CR1000, CR10(X) and CR500/CR510, and the 200 mV range for the CR3000 and CR23X are suitable.

The parameter code for the input range also specifies the measurement integration time. The slow or 60 Hz rejection integration gives a more noise-free reading. A fast integration takes less power and allows for faster throughput.

5.2 Calibration Factor and Multiplier

All SP Lite2 sensors have a sensitivity (calibration factor) listed on the sensor and the calibration sheet (see Appendix A for example). Solar radiation can be reported as an average flux density ($W\ m^{-2}$) or daily total flux density ($MJ\ m^{-2}$). The appropriate multipliers for the measurement instruction are listed in Table 3. Programming examples are given for both average and daily total solar radiation.

Units	Multipliers	Output Processing
MJ m-2	$t*[1/(1000*C)]$	(P72 total fluxes)
KJ m-2	$t*(1/C)$	(P72 total fluxes)
W m-2	$1000/C$	(P71 flux density)
KW m-2	$1/C$	(P71 flux density)
cal cm-2	$t*0.0239*(1/C)$	(P72 total fluxes)
cal cm-2 min-1	$1.434*(1/C)$	(P71 flux density)
t = the datalogger program execution interval in seconds		
C = Sensitivity (calibration factor with units of $\mu V/W/m2$)		

5.3 Program Examples for Average Solar Radiation

The examples below give the appropriate datalogger code for the CR1000 and CR10X dataloggers, using the differential voltage measurement instruction.

Examples 1 (CR1000) and 2 (CR10X) show the program instructions used to measure the signal from the SP Lite2. A thirty-minute average is calculated and stored in final storage.

Wiring for Examples 1 and 2

Colour	Function	CR1000 Channels	CR10X Channels
Red	Radiation Signal	1H	1H
Blue	Signal Reference	1L	1L
	Jumper to	\neq	AG
Black	Shield	G	G

EXAMPLE 1. Sample Instructions used to Measure an Average Flux with a CR1000

```
{CR1000}

'////////// DECLARATIONS //////////
Public W_m2

'////////// OUTPUT SECTION //////////
DataTable(Average_Flux,true,-1)
  OpenInterval
  DataInterval(0,30,Min,10)
  Average(1, W_m2, FP2, 0)
EndTable

'////////// PROGRAM //////////
BeginProg

  Scan(5,Sec, 3, 0)

  VoltDiff(W_m2, 1, mV250, 1, True, 0, _60Hz, 12.3457, 0)

' Set negative values to zero
  If (W_m2 < 0) Then
    W_m2 = 0
  EndIf

  CallTable Average_Flux
  NextScan
EndProg
```

EXAMPLE 2. Sample Instructions used to Measure an Average Flux with a CR10X

```
;{CR10X}
;
*Table 1 Program
  01: 5          Execution Interval (seconds)

1: Volt (Diff) (P2)
1: 1          Reps
2: 24         250 mV 60 Hz Rejection Range ; **
3: 1          DIFF Channel ; *
4: 1          Loc [ W_m2    ] ; *
5: 12.3457    Multiplier ; ***
6: 0          Offset

; Set negative values to zero
2: If (X<=>F) (P89)
1: 1          X Loc [ W_m2    ]
2: 4          <
3: 0          F
4: 30         Then Do

  3: Z=F x 10^n (P30)
  1: 0          F
  2: 0          n, Exponent of 10
  3: 1          Z Loc [ W_m2    ]

4: End (P95)
```

```

5: If time is (P92)
1: 0   Minutes (Seconds --) into a
2: 30   Interval (same units as above)
3: 10   Set Output Flag High (Flag 0)

6: Real Time (P77)^20296
1: 0220   Day,Hour/Minute (midnight = 2400)

7: Average (P71)^26841
1: 1   Reps
2: 1   Loc [ W_m2   ]

; * Proper entries will vary with program and input channel assignments.
; ** The 250 mV range for CR10(X) and CR500/CR510, the 200 mV range for the CR23X,
; and the 500 mV range for the 21X and CR7.
; *** See Table 3 for alternative multipliers.

```

5.4 Program Examples for Total Solar Radiation

In Examples 3 and 4 a daily total flux density is found. This total flux density is in $\text{MJ m}^{-2} \text{day}^{-1}$. Negative values are set to zero before they are added to the running total.

5.4.1 Output Format Considerations

If the solar radiation is totalized in units of kJ m^{-2} , there is a possibility of overranging the output limits. The largest number that the CR10X datalogger can output to final storage is 6999 in low resolution and 99999 in high resolution (Instruction 78, Set Resolution). This is not a concern with the CR1000 default floating point data value. However, in the following examples the output units will be the same.

Assume that the daily total flux density is desired in kJ m^{-2} . Assume an irradiance of 0.5 kW m^{-2} , the maximum low resolution output limit will be exceeded in just under four hours. This value was found by taking the maximum flux density the datalogger can record in low resolution and dividing by the total hourly flux density.

$$3.9 \text{ hr} = \frac{6999 \text{ kJ m}^{-2}}{(0.5 \text{ kJ m}^{-2} \text{ s}^{-1})(3600 \text{ s hr}^{-1})} \quad (1)$$

To circumvent this limitation, record an average flux (see Examples 1 or 2). Then, during post processing, multiply the average flux by the number of seconds in the output interval to arrive at an output interval flux density. Sum the output interval totals over a day to find a daily total flux density.

Another alternative is to record total flux using the high resolution format (Instruction 78, see CR10X Datalogger manuals for details). The disadvantage of the high resolution format is that it requires four bytes of memory per data point, consuming twice as much memory as low resolution.

Wiring for Examples 3 and 4

Colour	Function	CR1000 Channels	CR10X Channels
Red	Radiation Signal	S.E. Channel 1	S.E. Channel 1
Blue	Signal Reference	⊕	AG
Black	Shield	G	G

EXAMPLE 3. Sample Instructions used to Measure a Daily Total Flux Density with a CR1000

```
{CR1000}

\//////////////////////////////////// DECLARATIONS ///////////////////////////////////
Public MJ_m2 As Long

\//////////////////////////////////// OUTPUT SECTION ///////////////////////////////////
DataTable(Total_Flux_Density,true,-1)
  OpenInterval
  DataInterval(0,1440,Min,10)
  Totalize(1, MJ_m2, FP2, 0)
EndTable

\//////////////////////////////////// PROGRAM ///////////////////////////////////
BeginProg

  Scan(5,Sec, 3, 0)

  VoltSe(MJ_m2, 1, mV250, 1, False, 0, _60Hz, 0.00012, 0)

' Set negative values to zero
  If (MJ_m2 < 0) Then
    MJ_m2 = 0
  EndIf

  CallTable Total_Flux_Density
  NextScan
EndProg
```

EXAMPLE 4. Sample Instructions used to Measure a Daily Total Flux Density with a CR10X

```
};{CR10X}
;
*Table 1 Program
  01: 5          Execution Interval (seconds)

1: Volt (SE) (P1)
1: 1    Reps
2: 24   250 mV 60 Hz Rejection Range ; **
3: 1    SE Channel ; *
4: 1    Loc [ MJ_m2    ] ; *
5: .00012 Multiplier ; ***
6: 0    Offset
```

```
; Set negative values to zero

2: If (X<=>F) (P89)
1: 1    X Loc [ MJ_m2  ]
2: 4    <
3: 0    F
4: 30   Then Do

      3: Z=F x 10^n (P30)
      1: 0    F
      2: 0    n, Exponent of 10
      3: 1    Z Loc [ MJ_m2  ]

4: End (P95)

5: If time is (P92)
1: 0    Minutes (Seconds --) into a
2: 1440 Interval (same units as above)
3: 10   Set Output Flag High (Flag 0)

6: Real Time (P77)^23
1: 1220 Year,Day,Hour/Minute (midnight = 2400)

7: Totalize (P72)^23429
1: 1    Reps
2: 1    Loc [ MJ_m2  ]

; -Input Locations-
; 1 MJ_m2

; * Proper entries will vary with program and input channel assignments.
; ** The 250 mV range for CR10(X) and CR500/CR510, the 200 mV range for the CR23X,
; and the 500 mV range for the 21X and CR7.
; *** See Table 3 for alternative multipliers.
```

6. Maintenance

The SP Lite2 is an ‘all weather’ instrument and is very stable, but should be handled with care. It requires little periodic maintenance, apart from cleaning the sensor surfaces carefully with a soft cloth using water or alcohol.

6.1 Calibration

It is recommended that the SP Lite2 is checked, and re-calibrated if necessary, every two years. The calibration can be checked by running the SP Lite2 in parallel with a reference sensor for at least two sunny days, and then comparing the daily readings. The reference sensor should either be a higher standard pyranometer, or an SP Lite2 that is kept stored and used solely for this purpose. If results differ by more than 5 percent, the sensor should be returned for re-calibration. Please contact Campbell Scientific for further details.

7. Troubleshooting

7.1 Pyranometer produces no apparent output

If your pyranometer does not appear to be working at all, do the following checks:

- With the SP Lite2 disconnected from the datalogger, connect a volt meter to the Red (+) and Blue (-) wires. The voltage range should be ~ 0-120 mV for 0-1100 W m⁻² radiation.
- If this appears to produce no results, measure the impedance of the sensor across the Red and Blue wires. The impedance reading should be less than 1M Ω . If it is less than 5 Ω , a short circuit is indicated. If it is ‘infinite’, the sensor is damaged, or the cable is broken.

7.2 Readings are not as expected

- Under full sunlight the expected radiation value is about 1000 W m⁻².
- Verify that the multiplier parameter in the measurement instruction is correct for the desired units (e.g., W m⁻², see Section 5 above).
- Check the datalogger program for errors.

If you cannot resolve your problems, please contact Campbell Scientific for further advice.