

INSTRUCTION MANUAL



SDM-IO16 16 Channel Input/Output Expansion Module

Revision: 4/09



Copyright © 2002-2009
Campbell Scientific, Inc.

PLEASE READ FIRST

About this manual

Please note that this manual was originally produced by Campbell Scientific Inc. (CSI) primarily for the US market. Some spellings, weights and measures may reflect this origin.

Some useful conversion factors:

Area: 1 in² (square inch) = 645 mm²

Length: 1 in. (inch) = 25.4 mm
1 ft (foot) = 304.8 mm
1 yard = 0.914 m
1 mile = 1.609 km

Mass: 1 oz. (ounce) = 28.35 g
1 lb (pound weight) = 0.454 kg

Pressure: 1 psi (lb/in²) = 68.95 mb

Volume: 1 US gallon = 3.785 litres

In addition, part ordering numbers may vary. For example, the CABLE5CBL is a CSI part number and known as a FIN5COND at Campbell Scientific Canada (CSC). CSC Technical Support will be pleased to assist with any questions.

WARRANTY AND ASSISTANCE

This equipment is warranted by CAMPBELL SCIENTIFIC (CANADA) CORP. ("CSC") to be free from defects in materials and workmanship under normal use and service for **twelve (12) months** from date of shipment unless specified otherwise. ***** **Batteries are not warranted.** ***** CSC's obligation under this warranty is limited to repairing or replacing (at CSC's option) defective products. The customer shall assume all costs of removing, reinstalling, and shipping defective products to CSC. CSC will return such products by surface carrier prepaid. This warranty shall not apply to any CSC products which have been subjected to modification, misuse, neglect, accidents of nature, or shipping damage. This warranty is in lieu of all other warranties, expressed or implied, including warranties of merchantability or fitness for a particular purpose. CSC is not liable for special, indirect, incidental, or consequential damages.

Products may not be returned without prior authorization. To obtain a Return Merchandise Authorization (RMA), contact CAMPBELL SCIENTIFIC (CANADA) CORP., at (780) 454-2505. An RMA number will be issued in order to facilitate Repair Personnel in identifying an instrument upon arrival. Please write this number clearly on the outside of the shipping container. Include description of symptoms and all pertinent details.

CAMPBELL SCIENTIFIC (CANADA) CORP. does not accept collect calls.

Non-warranty products returned for repair should be accompanied by a purchase order to cover repair costs.



CAMPBELL SCIENTIFIC
C A N A D A C O R P .

11564 - 149 street - edmonton - alberta - T5M 1W7
tel 780.454.2505 fax 780.454.2655

www.campbellsci.ca

IMPORTANT – Please Read First

Datalogger Instruction 188 – Software Requirements

1. PC208W Datalogger Support Software

NOTE PC208W support of SDM-IO16 Instruction 188 requires replacement of some PC208W files

Datalogger Instruction 188 for the SDM-IO16 was developed after the release of PC208W version 3.3. Campbell Scientific will not release another version of PC208W but instead will offer the next generation datalogger support software which is LoggerNet. Instruction 188 is supported in LoggerNet version 2.1 and later.

A special patch to PC208W version 3.3 is available from our website to give support for Instruction P188. If you do not already have version 3.3, follow steps 1 to 3 below, otherwise start at step 4. You must have PC208W version 3.0 or later to complete this upgrade.

1. Go to Campbell Scientific website www.campbellsci.com/resource.html.
2. In section “Product Upgrades”, click on link [3.3](#) to link to the patch for PC208W/P.
3. Follow instructions for On-line Upgrades. An email will be sent to you with a link to the required files for the patch. The patch will upgrade PC208W to version 3.3.
4. Next, download file `ed16update.exe` from our ftp site, <ftp://ftp.campbellsci.com/pub/csl/outgoing/> to a location of your choice. Open the self-extracting file. The default directory is **C:\PC208W\BIN** which will be correct for almost all PC208W installations. (If your original installation was to some different disk or directory, amend the path as required, and install to the appropriate \BIN directory.) Select other options using the radio buttons.

NOTE This upgrade also includes support for Campbell Scientific’s CS616 sensor.

5. Follow the instructions below to upgrade your Datalogger Operating System.

2. CR23X and CR10X Operating System Requirements

NOTE

Use of SDM-IO16 Instruction 188 requires newer datalogger operating systems for the CR23X and CR10X.

The following table lists the datalogger operating systems required for support of Instruction 188. To determine which operating system is presently installed in a datalogger, use the *B mode. See your datalogger manual for a detailed description.

| Campbell Scientific Datalogger | Required Operating System Version --Listed version or later-- |
|--------------------------------|--|
| CR10X | 1.17 |
| CR23X | 1.14 |

Campbell Scientific datalogger operating systems are easily downloaded from our website page, www.campbellsci.com/resource.html. Go to section Product Upgrades and click on the link for the appropriate datalogger.

SDM-IO16 Table of Contents

PDF viewers note: These page numbers refer to the printed version of this document. Use the Adobe Acrobat® bookmarks tab for links to specific sections.

| | |
|--|-----------|
| 1. Introduction | 1 |
| 2. Specifications | 2 |
| 2.1 General | 2 |
| 2.2 Port Specifications (Output Mode) | 3 |
| 2.3 Port Specifications (Input Mode) | 3 |
| 2.4 Pulse Counting Specifications | 3 |
| 3. Power Considerations | 5 |
| 4. Installation | 6 |
| 4.1 Terminal Connections | 7 |
| 5. Address Selection Switches | 8 |
| 6. Programming the Datalogger | 9 |
| 6.1 General Principles | 9 |
| 6.2 CRBasic Programming | 10 |
| 6.2.1 SDMIO16 Instruction | 10 |
| 6.2.2 SDMCD16AC Instruction | 11 |
| 6.2.3 SDMSpeed Instruction | 11 |
| 6.3 Edlog Programming | 12 |
| 6.3.1 Instruction 188 (CR10X and CR23X) | 12 |
| 6.3.2 Instructions 104 and 29 (CR10, CR7, 21X) | 14 |
| 6.4 Command Codes for SDMIO16 Instruction and Instruction 188 | 15 |
| 7. Program Examples | 18 |
| 7.1 SDMIO16 Example | 18 |
| 7.2 A CR10X Program Using the Outputs for Control of a Greenhouse Heating and Cooling System | 18 |
| 7.3 A CR10X Program which Measures Four Frequency Inputs (Anemometers) and Four Switch Closure Inputs (Rain Gauges) ... | 24 |
| 7.4 A CR10X Program that uses the Interrupt Subroutine in the Datalogger to Record the Time of Change of any one of the Ports on an SDM-IO16 | 26 |

Appendices

| | |
|--|------------|
| A. General Principles of Pulse and Frequency Measurements | A-1 |
| A.1 Introduction..... | A-1 |
| A.2 Frequency and Duty Cycle Measurement Range..... | A-1 |
| A.3 Resolution of Frequency Measurements..... | A-2 |
| A.4 Resolution of Duty Cycle Measurements..... | A-2 |
| A.5 Debounce Filtering..... | A-3 |
| B. Command Code Listing | B-1 |

Figures

| | |
|--|---|
| 1. SDM-IO16 (with mounting brackets)..... | 1 |
| 2. Simplified Equivalent Port Circuits | 5 |
| 3. Connection Block Diagrams | 6 |
| 4. Use of Terminal Blocks | 7 |
| 5. Address Selection Switch | 8 |

Tables

| | |
|--|----|
| 1. Datalogger to SDM-IO16 Connections..... | 6 |
| 2. Bit Period Value..... | 12 |
| 3. Summary of the Common Command Codes relative to Port Number and Function | 17 |

SDM-IO16 16 Channel Input/Output Expansion Module

The SDM-IO16 (see Figure 1) is a synchronously addressed peripheral. It has 16 ports that can be configured for input or output which expand the number of control ports of the datalogger. It is fully compatible with Campbell Scientific's CR800, CR850, CR1000, CR3000, CR5000, CR10X, and CR23X dataloggers.



FIGURE 1. SDM-IO16 (with mounting brackets)

1. Introduction

The SDM-IO16 expands the digital input and/or output capability of Campbell Scientific dataloggers. It offers similar functionality to the control ports of the majority of Campbell Scientific dataloggers.

When a port is configured as an input it can measure the logical state of the port, count pulses, measure the frequency of and determine the duty cycle of signals applied to the port. In pulse counting mode there is also an option to enable switch debounce filtering so the unit can accurately count switch closure events. The SDM-IO16 measures the frequency of signals by measuring the time between pulses, thereby giving relatively high-resolution measurements even for low frequency signals.

The module can also be programmed to generate an interrupt signal to the datalogger when one or more input signals change state.

When configured as an output, each port can be set to 0 or 5 V by the datalogger. In addition to being able to drive normal logic level inputs, when an output is set HI a 'boost' circuit allows it to source a current of up to 100 mA, allowing direct control of low voltage valves, relays etc.

The SDM-IO16 is a synchronously addressed datalogger peripheral. Datalogger control ports 1, 2 and 3 are used to address the SDM-IO16 and exchange digital data with it. This module utilizes advanced error checking techniques to ensure correct transmission of data to and from the module. Up

to sixteen SDM-IO16s may be addressed, making it possible to control a maximum of 256 ports from the first three datalogger control ports.

The SDM-IO16 is supplied with two removable mounting brackets that attach to the ends of the unit, as shown in Figure 1.

NOTE

The full functions and support for the error checked communications protocol require an operating system for the datalogger and Edlog template files that post-dates March 2002. The CR10X and CR23X with older operating systems and the CR10, CR7 and 21X dataloggers can use I/O Instruction 104 to set and use the ports for output only.

2. Specifications

2.1 General

| | |
|---------------------------------|---|
| Compatible dataloggers: | CR800, CR850, CR1000, CR3000, CR5000, CR10X, and CR23X. (CR10, 21X, and CR7 output modes only.) |
| Operating voltage: | 12 VDC nominal (9 to 18 V). |
| Current drain at 12V DC: | 600 μ A typical standby (All ports HI, no load, not pulse counting). Maximum (no output load): 3 mA active with all 16 ports counting pulses at 2 KHz. Above the quiescent level, power consumption is roughly proportional to input signal frequency and number of ports used. Current drawn from any output must be added to the quiescent level to give the total current drain. |
| SDM and I/O port: | 0/5 V logic level ports compliant with the requirements of the CS SDM protocol — these are designed for connection to the datalogger's control/SDM ports. |
| Operating temperature: | -25°C to +50°C standard |
| Size: | 235 mm over mounting brackets x 100 mm x 24 mm |

| | |
|--------------------------------|---|
| Mounting: | Mounting brackets have two holes at 225 mm nominal spacing. Mounting screws and plastic inserts suitable for use with Campbell Scientific enclosures are also supplied. |
| Weight: | 350 g (including brackets) |
| EMC status: | Complies with EN61326:1997 |
| Total SDM cable length: | 6 m maximum recommended |

2.2 Port Specifications (Output Mode)

| | |
|---|---|
| Output voltage (no load): | Output ON/HI, Nominal 5 V (Minimum 4.5 V) Output OFF/LO, Nominal 0 V (Maximum 0.1 V) |
| Output sink current: | Output will sink 8.6 mA from a 5 V source ¹ |
| Output source current: | Output will source 42 mA @ 3 V, 133 mA short-circuited to ground ¹ |
| Max. output current: (total for all outputs) | Limited by the 12 V supply. |

2.3 Port Specifications (Input Mode)

| | |
|--------------------------|--|
| Input voltage: | Input high, 4.0 V minimum threshold Input low, 1.0 V maximum threshold All inputs feature Schmitt triggered detectors. |
| Input protection: | The input is clamped at -0.6 V and +5.6 V relative to ground via a 33 Ω resistor ¹ . This will withstand a continuous current flow of 200 mA (including that which might be caused by accidentally connecting directly to a 12 V supply). To limit power dissipation and damage at higher voltages than 12 V, an external series current limiting resistor is recommended. |
| Input impedance: | The input is biased to +5 V relative to ground by a 100 kohm resistor. |

2.4 Pulse Counting Specifications

| | |
|---------------------------|--|
| Maximum frequency: | 2.048 KHz on all channels simultaneously with switch debounce-mode set off, with a 50/50 duty cycle. 150 Hz on all channels with default switch debounce timing enabled and a 50/50 duty cycle ² . |
|---------------------------|--|

| | |
|----------------------------------|---|
| Minimum frequency: | a frequency of 0 Hz is measured if there are less than two high-to-low signal transitions in the measurement interval. |
| Minimum pulse width: | a pulse must stay high or low for a minimum of 244 μ sec for a change of state or pulse to be counted. |
| Switch debounce timing: | with the default settings a switch between the input and G must remain closed for 3.17 msec and then remain open for 3.17 msec, to be counted as a closure ² . The debounce time can be changed from the user program. |
| Accuracy: | internal clock accuracy $\pm 0.01\%$ (worst case) over the standard temperature range of -25 to +50°C. See also Appendix A for a discussion on frequency resolution. |
| Duty cycle resolution: | this depends on frequency and measurement interval - See Appendix A. The average duty cycle can be measured for signals up to 4 kHz. |
| Max measurement interval: | for frequency or duty cycle measurements the datalogger must request a measurement at an interval no longer than 15.9375 seconds. Each channel can be measured at different intervals, both for frequency and duty cycle. |

¹If more detailed input/output characteristics are required, experienced users should consult the equivalent circuit diagrams shown in Figure 2.

²See Appendix A for a more detailed discussion of switch debounce, resolution and accuracy.

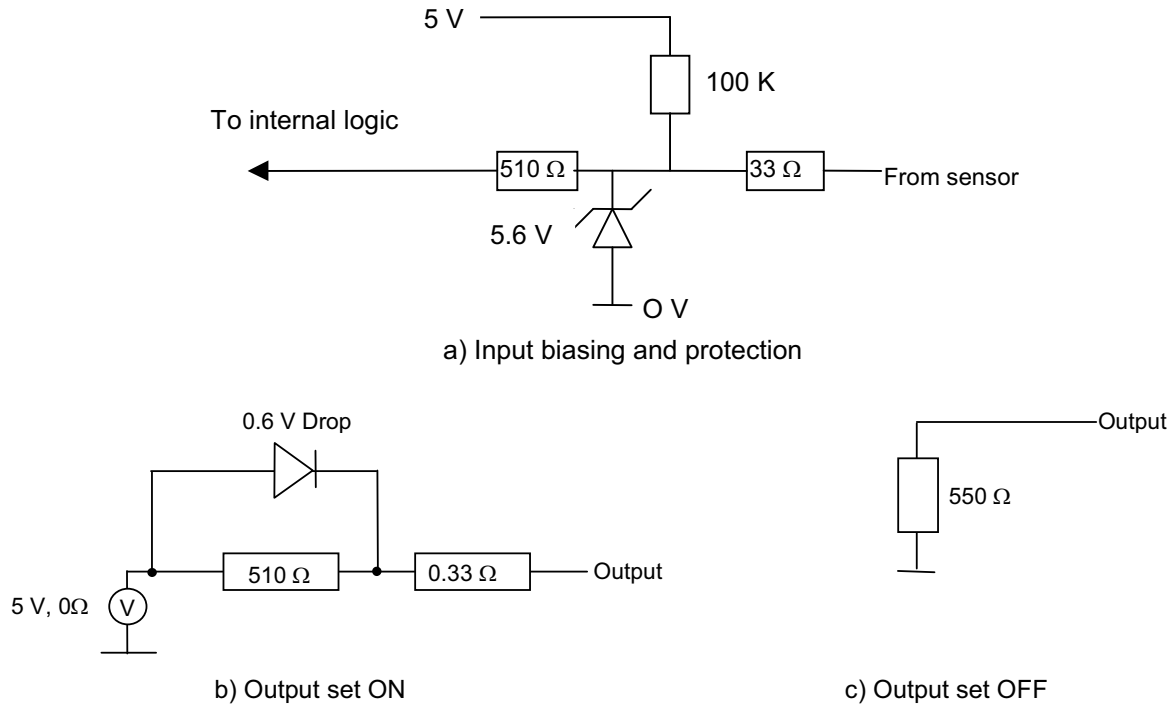
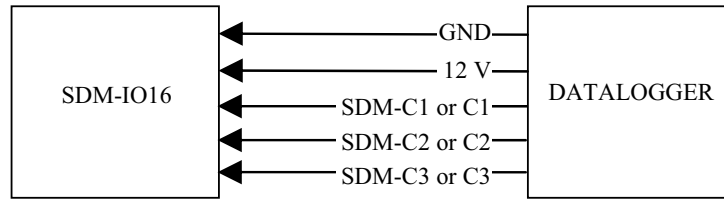

FIGURE 2. Simplified Equivalent Port Circuits

3. Power Considerations

For most applications, especially for pulse counting or status inputs, it is more normal to use the datalogger supply to power the SDM-IO16, as shown in Figure 3(a).

When being used for control and outputting current the SDM-IO16 power requirements can be large compared to most Campbell Scientific products when driving significant loads. For this type of application an external power supply, as shown in Figure 3(b), is recommended to power the SDM-IO16.



a) Connection with Datalogger Supply

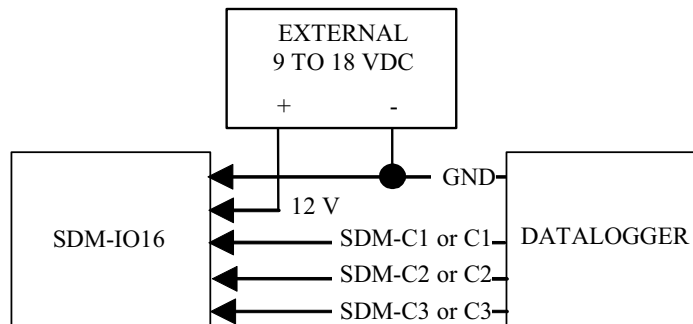

(b) Connection with External Supply

FIGURE 3. Connection Block Diagrams

4. Installation

For correct operation the SDM-IO16 must be installed where there is no risk of water ingress or condensation.

CAUTION

The order in which connections are made is critical. *Always connect 12 V first*, followed by ground, then the control ports.

The CABLE5CBL-L or a similar cable connects the datalogger to the SDM-IO16. For datalogger connections, see Table 1, below. Please refer to Figure 4 for details of how to use the spring-loaded terminals.

| TABLE 1. Datalogger to SDM-IO16 Connections | | | |
|---|----------|---|---------------------------------------|
| | | Datalogger | |
| Connection Order | SDM-IO16 | CR800, CR850, CR1000, CR10(X), 21X, CR7 | CR3000, CR5000 |
| First | 12 V | 12 V on datalogger or external supply | 12 V on datalogger or external supply |
| Second | ⏏ | ⏏ or G | G |
| | C1 | C1 | SDM-C1 |
| | C2 | C2 | SDM-C2 |
| | C3 | C3 | SDM-C3 |

Multiple SDM-IO16s can be wired in parallel by connecting the datalogger connections of one SDM-IO16 to the next.

The transient protection of the SDM-IO16 relies on a low resistance path to earth. Ensure that the ground return wire has as low a resistance as possible. Where very long cable runs are likely, or where lightning damage is a possibility, the SDM-IO16 can be fitted with optional gas discharge tubes. Please contact Campbell Scientific for details.

NOTE

The total cable length should be as short as possible and typically should not exceed 6 m. For CRBasic dataloggers, longer cable lengths may be possible if the SDMSpeed instruction is used (see Section 6.2.3). Too long of cable length will adversely affect communication performance between the module and datalogger.

4.1 Terminal Connections

The SDM-IO16 uses spring-loaded terminal blocks, which provide quick, vibration resistant, connections. The output terminals are labeled 1 to 16. A common ground connector is provided between each pair of terminals

Use a screwdriver in either the top or front slot, as appropriate, to open the terminal spring. Strip any insulation from the wire to give 7 to 9 mm bare wire. Push the wire into the opening, and, while holding it in position, withdraw the screwdriver to release the spring. The wire will now be firmly held in place. See Figure 4, below.

NOTE

You cannot reliably insert more than one solid-core wire into one terminal connector unless the wires are soldered or clamped together. When inserting more than one stranded wire, twist the bare ends together before insertion.

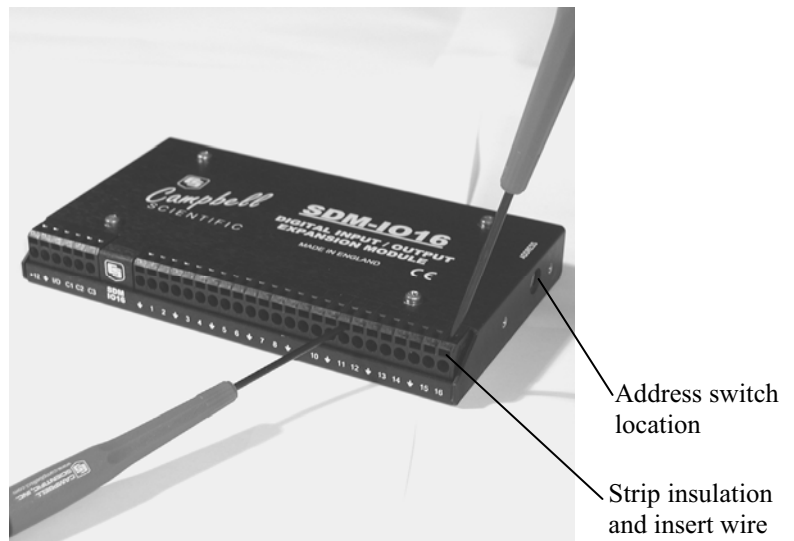

FIGURE 4. Use of Terminal Blocks

5. Address Selection Switches

Each SDM-IO16 can have 1 of 16 addresses. The factory-set address is 00. Table 3 shows switch position and the corresponding address. Figures 4 and 5 show the position of the switch. Note that you will have to remove the mounting bracket to gain access to this switch.

| Switch Setting | Decimal Address | Base 4 Address |
|----------------|-----------------|----------------|
| 0 | 0 | 00 |
| 1 | 1 | 01 |
| 2 | 2 | 02 |
| 3 | 3 | 03 |
| 4 | 4 | 10 |
| 5 | 5 | 11 |
| 6 | 6 | 12 |
| 7 | 7 | 13 |
| 8 | 8 | 20 |
| 9 | 9 | 21 |
| A | 10 | 22 |
| B | 11 | 23 |
| C | 12 | 30 |
| D | 13 | 31 |
| E | 14 | 32 |
| F | 15 | 33 |



FIGURE 5. Address Selection Switch

Each SDM-IO16 needs to be set to a unique address on the SDM bus, so that no two SDM peripherals share the same address.

6. Programming the Datalogger

6.1 General Principles

For recent dataloggers, there is a specific program instruction that is used to control operation of the SDM-IO16. The different variants of this command are described in Section 6.2.1 and Section 6.3.1 below. Older dataloggers can use different commands to control the output functions only; if you have such a datalogger please go to Section 6.3.2 now as the remainder of this section will not be relevant.

The general form of the command specific to the SDM-IO16 includes:

- parameters to specify which module to address,
- a command code to specify what the module is to do, and
- a number of control parameters and pointers to input locations /variables which can hold data (either read by the module or which are used to control the outputs of the module).

The instruction differs from many others in that, rather than addressing a variable number of ports (using a 'reps' parameter), ports are dealt with in blocks of 1, 4, 8 or 16 ports at a time. The specific port(s) and number to be controlled is implicit in the command code used. This approach has been taken to improve the efficiency of programming and also to reduce the amount of data transferred between the module and datalogger via the SDM port.

The module can be reconfigured quite extensively from the controlling program to allow for more demanding applications. In most cases, though, operation is quite simple as on power-up the input/output ports of the SDM-IO16 default to input mode, with no switch debounce filtering and measurement of frequency and duty-cycle automatically starts for all ports.

For many input measurements, the controlling program in the datalogger can then simply be written to ask the SDM-IO16 for measurements of status, duty-cycle or frequency from any channel. The only constraint is that it must ask for duty cycle or frequency measurements more frequently than once every 15.9375 seconds (see Appendix A).

Where one or more channels will be used for output, one call of the instruction can be within the normal program structure to set those ports to either a fixed state, or a state dependent upon a variable in an input location.

Where ports will be used as switch closure inputs, where a change of state of a port will be used to toggle the I/O line (normally to generate an interrupt to the datalogger) or where the port is to be used as a fixed output, then it would be usual to include code that sends a command to the SDM-IO16 to configure the ports before they are used. See the program examples in Section 7.

The configuration of individual ports can also be changed during normal program operation, if required.

6.2 CRBasic Programming

Dataloggers that use CRBasic include our CR800, CR850, CR1000, CR3000, and CR5000.

6.2.1 SDMIO16 Instruction

The SDMIO16 instruction in CRBasic supports all of the functions of the SDM-IO16. The SDMIO16 instruction is described below; refer to section 7 for an example.

Syntax

SDMIO16 (Dest, Status, Address, Command, Mode Ports 16-13, Mode Ports 12-9, Mode Ports 8-5, Mode Ports 4-1, Mult, Offset)

Remarks

The ports on the SDM-IO16 can be configured for either input or output. When configured as input, the SDM-IO16 can measure the logical state of each port, count pulses, and measure the frequency of and determine the duty cycle of applied signals. The module can also be programmed to generate an interrupt signal to the datalogger when one or more input signals change state. When configured as an output, each port can be set to 0 or 5 V by the datalogger. In addition to being able to drive normal logic level inputs, when an output is set high a 'boost' circuit allows it to source a current of up to 100 mA, allowing direct control of low voltage valves, relays, etc.

| | |
|------------|---|
| Dest | The Dest parameter is a variable or variable array in which to store the results of the measurement (Command codes 1 - 69, 91, 92, 99) or the Source value for the Command Codes (70 - 85, 93 - 98). The variable array for this parameter must be dimensioned to accommodate the number of values returned (or sent) by the instruction. |
| Status | The Status parameter is used to hold the result of the command issued by the instruction. If the command is successful a 0 is returned; otherwise, the value is incremented by 1 with each failure. |
| SDMAddress | The SDMAddress parameter defines the address of the SDM-IO16 with which to communicate. Valid SDM addresses are 0 through 14. Address 15 is reserved for the SDMTrigger instruction. If the Repts parameter is greater than 1, the datalogger will increment the SDM address for each subsequent SDM-IO16 that it communicates with. |
| Command | The Command parameter is used to set up the SDM-IO16. Please read section 6.4 for detailed description of the controlling command codes. |
| Mode | Each Mode parameter is used to configure a bank of four ports when a Command code 86 through 90 is used (if any other Command Code is used, enter 0 for the Mode parameters). |

Mode is entered as a four digit parameter, where each parameter indicates the setting for a port. Ports are represented from the highest port number to the lowest, from left to right (e.g., 16 15 14 13; 12 11 10 9; 8 7 6 5; 4 3 2 1). There is a Mode for Ports 16 - 13, 12 - 9, 8 - 5, and 4 - 1. The valid codes are:

| Code | Description |
|------|---|
| 0 | Output logic low |
| 1 | Output logic high |
| 2 | Input digital, no debounce filter |
| 3 | Input switch closure 3.17 msec debounce filter |
| 4 | Input digital interrupt enabled, no debounce filter |
| 5 | Input switch closure interrupt enabled 3.17 msec, debounce filter |
| 6 | Undefined |
| 7 | Undefined |
| 8 | Undefined |
| 9 | No change |

Mult, Offset The Mult and Offset parameters are each a constant, variable, array, or expression by which to scale the results of the measurement.

6.2.2 SDMCD16AC Instruction

All but the oldest versions of the CR5000 operating system also support the SDMCD16AC instruction that can be used to control the SDM-IO16 for output mode only. This instruction should only be used if backward compatibility is required, as only the IO16 instruction supports error detection on communication between the peripheral and the datalogger.

6.2.3 SDMSpeed Instruction

The SDMSpeed instruction is used to change the bit period that the datalogger uses to clock the SDM data. Slowing down the clock rate may be necessary when long cable lengths are used to connect the datalogger and SDM devices.

The syntax of this instruction is as follows:

SDMSpeed ([BitPeriod](#))

The BitPeriod argument can be an integer or a variable. If the SDMSpeed instruction is not in the program, a default bit period is used. If 0 is used for the argument, the minimum allowable bit period is used. Table 2 shows the default, minimum allowable, and maximum bit period for each of our CRBasic dataloggers.

| Datalogger | Default Bit Period | Minimum Allowable Bit Period | Maximum Bit Period |
|-------------------|---------------------------|-------------------------------------|---------------------------|
| CR800, CR850 | 26.04 μ sec | 8.68 μ sec | 2.2 msec |
| CR1000 | 26.04 μ sec | 8.68 μ sec | 2.2 msec |
| CR3000 | 26.04 μ sec | 8.68 μ sec | 2.2 msec |
| CR5000 | 30 μ sec | 8 μ sec | 3 msec |

The equation used to calculate the bit rate depends on the datalogger used. The datalogger will round down to the next faster bit rate.

Equation for CR800, CR850, and CR1000:

$$\text{bit_rate} = \text{INT}((k * 72) / 625) * \text{Resolution}$$

Where:

k= the value entered in BitPeriod

Resolution=8.68 microseconds

Equation for CR3000:

$$\text{bit_rate} = \text{INT}((k * 144) / 625) * \text{Resolution}$$

Where:

k= the value entered in BitPeriod

Resolution= 4.34 μ sec.

Equation for CR5000:

$$\text{bit_rate} = \text{INT}(k * 20) * \text{Resolution}$$

Where:

k= the value entered in BitPeriod

Resolution=50 nsec.

6.3 Edlog Programming

Dataloggers that use Edlog include our CR10(X), CR23X, 21X, and CR7.

6.3.1 Instruction 188 (CR10X and CR23X)

Edlog Instruction 188, 'SDM-IO16', supports control of the SDM-IO16. This instruction is included in the latest versions of the operating systems for the CR10X and CR23X dataloggers. Instruction 188 is specifically designed to control the SDM-IO16, and takes the following form:

| | |
|---------|-----------------------------------|
| P188 | SDM-IO16 instruction |
| 01:99 | SDM address 0-15. |
| 02:9999 | Command number 0-255. |
| 03:FP | Ports 16-13 Mode 0-9999. |
| 04:FP | Ports 12-9 Mode 0-9999. |
| 05:FP | Ports 8-5 Mode 0-9999. |
| 06:FP | Ports 4-1 Mode 0-9999. |
| 07:9999 | Location number for return code. |
| 08:9999 | Start location number for values. |
| 09:FP | Multiplier. |
| 10:FP | Offset. |

The codes after the parameter number indicate the entry type, where 99 and 9999 signify two or four digit integer entries and FP indicates a floating point number entry, e.g. 1.234. The range of values you would enter with the SDM-IO16 is shown after the description of some parameters. A detailed description of the individual parameters follows.

Parameter 01 sets the SDM address number (see figure 5). This instruction accepts the address in decimal form. The factory setting is 0.

Parameter 02 specifies the command number, which is the main way of controlling what the SDM-IO16 does in response to a specific call of P188. The range of commands is described in Section 6.4.

Parameters 03...06 allows the entry of four digit numbers which allow a simple method of setting up the state or method of operation of each I/O port on the module. These parameters are only functional with commands 86...90, otherwise they can be left at zero. Each digit relates to one I/O port on the module in the order shown above; for example 03 relates to Ports 16-13, 06 relates to Ports 4-1 etc. Ports are read in descending numerical order from left to right.

Available modes are:

- 0 = Output logic low
- 1 = Output logic high
- 2 = Input digital, no debounce filter
- 3 = Input switch closure 3.17msec debounce filter
- 4 = Input digital interrupt enabled, no debounce filter
- 5 = Input switch closure interrupt enabled 3.17msec, debounce filter
- 6 = Undefined.
- 7 = Undefined.
- 8 = Undefined.
- 9 = No change.

For example parameter 3 for ports 16-13 could be 9213 which from the list below would set port 16 = no change in operation, port 15 = digital input, port 14 = output logic 1 and port 13 = switch closure input.

Parameter 07 specifies the input location number to hold a counter to indicate errors in communicating with the SDM-IO16. All communication between the SDM-IO16 and the datalogger is error checked. If, for any reason, there is an error then the datalogger will retry the instruction 3 times before continuing with the next instruction. If, after 3 retries, the communication was not successful, then the number in this location will increment. If later communication is successful then this location will be reset to zero. This counter is used normally only to diagnose problems with SDM communications which may require more careful wiring of the SDM bus or

reduction of the SDM-bus speed if the cables are long (see details of P115 in the datalogger manual).

Parameter 08 specifies the number of the input location where data is either read from or written to, depending on the command being used. This may be the first location in a series of locations.

Parameter 09 is a multiplier that is applied to data read to and from input locations. Normally you would set this to 1.000, unless applying a calibration factor to data being read from the SDM-IO16.

Parameter 10 is an offset that is applied to data read to and from input locations. Normally you would set this to 0.000, unless applying a calibration factor to data being read from the SDM-IO16.

See programming examples in Section 7.

6.3.2 Instructions 104 and 29 (CR10, CR7, 21X)

Instruction 104 is normally used by the CR10/10X, CR23X, CR7 and 21X to control the SDM-CD16(AC/D) digital output interfaces. Older CR7s used a similar instruction (P29). These instructions can be used to control the output status only of the SDM-IO16, as it emulates a SDM-CD16 if it receives commands from the datalogger sent by this instruction and if the SDM address of the module also matches that sent by the datalogger.

This can be useful if you need to use the SDM-IO16 in place of an SDM-CD16 or any of its later variants, or if you need to use one for output expansion only, using a datalogger that has an old operating system that does not support instruction P188 mentioned above.

If your datalogger does support P188 though, it is best to use that instruction as commands sent to the SDM-IO16 are checked for corruption and resent if a corruption is detected. This technique ensures more reliable operation, especially in electronically noisy environments.

The Instruction descriptions are shown below.

| Instruction 104 – SDM-CD16 used with CR10/10X, CR23X, CR7 and 21X Dataloggers | | |
|--|-------------|--|
| Parameter | Type | Description |
| 1 | 2 | Reps (No. of modules sequentially addressed) |
| 2 | 2 | Starting Address (base 4: 00..33) |
| 3 | 4 | Starting Input Location |
| Execution Time = 2 ms per Rep for the CR10/10X and CR23X 3.5 ms per Rep for the 21X and CR7 | | |

| Instruction 29 –used with older CR7s | | |
|---|-------------|--|
| Parameter | Type | Description |
| 1 | 2 | Reps (No. of modules sequentially addressed) |
| 2 | 2 | Device (2 = SDM-CD16/SDM-IO16) |
| 3 | 2 | Starting Address (base 4: 00..33) |
| 4 | 2 | Card (Excitation card No.) |
| 5 | 4 | Starting Input Location |
| Execution Time = 150ms to 190ms per Rep | | |

Please note that these instructions use base 4 addressing. See the table with Figure 5 to see the matching setting of the address switch on the SDM-IO16 that equates to any base 4 address.

The number of SDM-IO16s to be addressed is defined by the Reps (repetitions) parameter. Each Rep sequentially addresses (00, 01, 02,...32, 33) SDM-IO16s, starting with the address specified in parameter 2 (parameter 3 for Instruction 29).

For each repetition, the 16 ports of the addressed SDM-IO16 are set according to 16 sequential input locations starting at the input location specified in parameter 3 (parameter 5 for Instruction 29). Any non-zero value stored in an input location activates (sets HI 5V) the associated SDM-IO16 port. A value of zero (0) de-activates the port (sets LO 0V). For example, assuming two repetitions and a starting input location of 33, outputs 1 to 16 of the first SDM-IO16 are set according to input locations 33 to 48, and outputs 1 to 16 of the second SDM-IO16 are set according to input locations 49 to 64.

For older CR7s with Instruction 29, the Device (parameter 2) specifies what type of synchronously addressed peripheral is to be addressed. The Device code for an SDM-CD16/IO16 is 2.

For Instruction 29 only (older CR7s), the Card parameter (parameter 4) specifies which 725 Excitation Card is being used for the control port signals. The Reps parameter does not advance beyond the specified Card, requiring another Instruction 29 for each 725 Excitation Card used.

6.4 Command Codes for SDMIO16 Instruction and Instruction 188

The same command codes are used for all datalogger types that support the SDM-IO16 instruction, therefore this section applies to both forms of instruction.

There are approximately 100 command codes; the full list is tabulated in Appendix B. The reason there are so many codes is that each type of action is generally possible for either a single or block of ports of various sizes, as discussed in section 6.1 above. A summary table of common command codes is shown in Table 3, below. There are only a relatively small number of different types of action that allows the commands to be grouped, as follows:

Pulse counting (1..23): these read the counts accumulated on the specified ports since they were last read. The maximum number of counts possible is 65535. If the count has not been read before this maximum is reached, this figure will roll over (from 65535 back to 0) at this point. The count is incremented when there is a low to high transition on the port.

Frequency measurement (24..46): these read the average frequency on specified ports since the last time a frequency command was called. See Appendix A for a full discussion of the effects of sample rate on frequency of measurement. Generally, the longer the sample rate the higher the resolution. However, the interval between frequency commands for any one port must be less than 15.9375 seconds.

Duty cycle measurement (47..69): Read the average duty cycle on the specified ports since the last duty cycle command for that port. See Appendix A for a full discussion of the effects of sample rate on duty cycle measurement. Generally, the longer the sample rate the higher the resolution. However, the interval between duty cycle commands for any one port must be less than 15.9375 seconds. The value output is a number between 0 and 100 that indicates the percentage of time the port was high.

Set the port debounce time (70..85): sets the debounce filtering time in multiples of 244 μ sec from 0 to 255 on the specified port. On power-up, the default time parameter is set to 0, i.e. no debounce filtering. If debounce filtering is enabled using one of the command codes 86..90, this parameter is set to 12, equivalent to a filter time of 3.17msec. See Appendix A for full details of the operation of this filter and the timing.

Configure the ports (86..90): these let you set the configuration of each port using parameters (3..6) that form part of the instruction. The options allow setting of output state or input filtering and whether a port will cause the I/O line to generate an interrupt pulse to the datalogger.

Read the port states (91..92): reads the state of all the ports into either one or 16 sequential input locations. For normal logic input a value of 0 is returned for the low state and a value of 1 is returned for the high state, while for switch closures 0 and 1 relate to closed and open. The current state of all ports is read, even if some are being used for outputs or frequency inputs.

Set the port states (93..94): sets the pattern of the state of the port outputs either from a single location or 16 sequential locations. These commands will only change the state of ports already set to output (using one of the command codes 86..90, 95 or 96). The pattern is stored internally, and so if a port is subsequently changed from input to output (using command code 95 or 96) the port will then change to match that set by an earlier call with command code 93 or 94.

Set the direction (input or output) of the ports (95..96): sets the direction of the ports either from a single location or 16 sequential locations. A value of 1 for a port sets it to input and a value of 0 sets it to output. On power-up, ports default to being inputs. If the direction is set to be an output immediately after power-up the state will be low.

Set the interrupt mask (97..98): these commands set a binary mask across the ports to define whether a change of state on the port (which must also be configured as an input) will generate an interrupt signal to the datalogger. When the appropriate mask bit representing the port is set to 1 an interrupt will be generated whenever the port changes state. The interrupt is generated by pulsing the I/O line on the SDM-IO16 until the datalogger responds by reading the port states of the SDM-IO16 in question using the SDM-IO16 command. The I/O line would normally be connected to a control port on the datalogger that activates an interrupt subroutine. When the I/O line is not pulsing, it switches to a high impedance state, which means that several similar I/O lines can be connected in parallel to the same control port on the datalogger.

Read module status (99): reads back the module operating system signature (which is calculated once at power-up), a number which identifies the operating system version plus two counters. These are a watchdog error counter which is incremented if the module crashes because of a software or hardware failure that required the SDM-IO16 to be reset and a communication error counter which represents the number of times SDM communication between the datalogger and SDM-IO16 failed. Both counters have a maximum limit of 255 counts and are reset to zero when this command code is used to read them. This command is only normally used when trying to diagnose problems with the datalogging system.

TABLE 3. Summary of the Common Command Codes (in *italics*) relative to port number and function.

| | | Port Number | | | | | | | | | | | | | | | |
|-----------------|----------------|-----------------|-----------|-----------|-----------|-----------|-----------|-----------|-----------|-----------|-----------|-----------|-----------|-----------|-----------|-----------|-----------|
| Action | Port Blocksize | 1 | 2 | 3 | 4 | 5 | 6 | 7 | 8 | 9 | 10 | 11 | 12 | 13 | 14 | 15 | 16 |
| Read Counts | 1 Port | <i>1</i> | <i>2</i> | <i>3</i> | <i>4</i> | <i>5</i> | <i>6</i> | <i>7</i> | <i>8</i> | <i>9</i> | <i>10</i> | <i>11</i> | <i>12</i> | <i>13</i> | <i>14</i> | <i>15</i> | <i>16</i> |
| | 4 Ports | <i>17</i> | | | | <i>18</i> | | | | <i>19</i> | | | | <i>20</i> | | | |
| | 8 Ports | <i>21</i> | | | | | | | | <i>22</i> | | | | | | | |
| | 16 Ports | <i>23</i> | | | | | | | | | | | | | | | |
| Read Frequency | 1 Port | <i>24</i> | <i>25</i> | <i>26</i> | <i>27</i> | <i>28</i> | <i>29</i> | <i>30</i> | <i>31</i> | <i>32</i> | <i>33</i> | <i>34</i> | <i>35</i> | <i>36</i> | <i>37</i> | <i>38</i> | <i>39</i> |
| | 4 Ports | <i>40</i> | | | | <i>41</i> | | | | <i>42</i> | | | | <i>43</i> | | | |
| | 8 Ports | <i>44</i> | | | | | | | | <i>45</i> | | | | | | | |
| | 16 Ports | <i>46</i> | | | | | | | | | | | | | | | |
| Read Duty Cycle | 1 Port | <i>47</i> | <i>48</i> | <i>49</i> | <i>50</i> | <i>51</i> | <i>52</i> | <i>53</i> | <i>54</i> | <i>55</i> | <i>56</i> | <i>57</i> | <i>58</i> | <i>59</i> | <i>60</i> | <i>61</i> | <i>62</i> |
| | 4 Ports | <i>63</i> | | | | <i>64</i> | | | | <i>65</i> | | | | <i>66</i> | | | |
| | 8 Ports | <i>67</i> | | | | | | | | <i>68</i> | | | | | | | |
| | 16 Ports | <i>69</i> | | | | | | | | | | | | | | | |
| Set Debounce | 1 Port | <i>70</i> | <i>71</i> | <i>72</i> | <i>73</i> | <i>74</i> | <i>75</i> | <i>76</i> | <i>77</i> | <i>78</i> | <i>79</i> | <i>80</i> | <i>81</i> | <i>82</i> | <i>83</i> | <i>84</i> | <i>85</i> |
| Set-up ports | 4 Ports | <i>89</i> | | | | <i>88</i> | | | | <i>87</i> | | | | <i>86</i> | | | |
| | 16 Ports | <i>90</i> | | | | | | | | | | | | | | | |
| Read State | 16 ports | <i>91 or 92</i> | | | | | | | | | | | | | | | |
| Set state | 16 ports | <i>93 or 94</i> | | | | | | | | | | | | | | | |
| Set Direct. | 16 ports | <i>95 or 96</i> | | | | | | | | | | | | | | | |
| Set Int Mask | 16 ports | <i>97 or 98</i> | | | | | | | | | | | | | | | |

7. Program Examples

7.1 SDMIO16 Example

The following program sets up and measures an SDM-IO16.

```

Public Version(4)
Public ComsStat(3)
Public Freq(16)
Public Setup(1)

Alias version(1)=OS_Ver
Alias version(2)=OS_Sig
Alias version(3)=WatchDog
Alias version(4)=ComErr

BeginProg

'Set up the SDM-IO16.
  Scan(1,sec,0,2)
  'Set IO ports 1-16 to input switch closure.
  SDMIO16(Setup,ComsStat(1),0,90,3333,3333,3333,1,0)
  NextScan

'Measure.
  Scan(1,sec,0,0)
  'get signature from io16
  SDMIO16(Version,ComsStat(2),0,99,0,0,0,1,0)
  'read frequency of all 16 channels
  SDMIO16(Freq(),ComsStat(3),0,46,0,0,0,1,0)
  NextScan

EndProg

```

7.2 A CR10X Program Using the Outputs for Control of a Greenhouse Heating and Cooling System.

The example is written for the CR10X Measurement and Control Module. The program concepts presented are the same for the CR23X, 21X and CR7 dataloggers with minor changes in the program code or use of different instructions as indicated.

In this example, the SDM-IO16 is used to control the temperature between 23°C and 28°C in each of five greenhouses. In each greenhouse the SDM-IO16 controls a heating unit, a refrigerating unit and an air mixing fan. Solid state relays might be used as the interface to these units. The rules for control are:

Heating unit:

Activate when temperature <23.5°C.

Deactivate when temperature >25.5°C.

Cooling unit:

Activate when temperature $>27.5^{\circ}\text{C}$.

Deactivate when temperature $<24.5^{\circ}\text{C}$.

Mixing fan:

Activate whenever the heating or cooling units are activated.

Activate for 5 minutes out of every 15 minutes.

The program assumes that the temperature measurements have been made, and that the average temperature for each greenhouse is computed and stored in input locations 1 to 5. For further information on loops and input location indexing, please refer to your datalogger manual.

Input location assignments are as follows:

| Input Location | Input Location Label | Description |
|-----------------------|-----------------------------|--|
| 1..5 | Temp #1..#5 | Avg. temp. greenhouse 1..5 |
| 10..14 | Heat #1..#5 | Heater control, greenhouse 1..5 SDM-IO16 Port 1..5 |
| 15..19 | Cool #1..#5 | Cooler control, greenhouse 1..5 SDM-IO16 Port 6..10 |
| 20..24 | Fan #1..#5 | Fan control, greenhouse 1..5 SDM-IO16 Port 11..15 |

```

;{CR10X}
;
*Table 1 Program
  01: 5           Execution Interval (seconds)

;First configure the IO16 if not already done
;If flag 1 is not set, i.e. the program has just
;been compiled or datalogger powered up.

;Omit the following four instructions if using
;an older datalogger with P104 instead of P188

1: If Flag/Port (P91)
  1: 21           Do if Flag 1 is Low
  2: 30           Then Do

```

```

;Call instruction 188 to set the ports as outputs
;with the outputs set low.
2: SDM-IO16 (P188)
  1: 00      SDM Address
  2: 90      Command Code Option      ;configure the ports
  3: 0000    Ports 16-13              ;Set all ports as output and low
  4: 0000    Ports 12-9
  5: 0000    Ports 8-5
  6: 0000    Ports 4-1
  7: 27      Return Code Loc [ ErrCount ] ;for return code
  8: 10      First Loc [ Heat_1 ]      ;for control values
  9: 1.0     Mult
  10: 0.0    Offset

;Set flag 1 high to indicate we have run the setup code
3: Do (P86)
  1: 11      Set Flag 1 High

4: End (P95)                                ;of IF block

;Measure the five temperatures, with 5 107 probes in this example
5: Temp (107) (P11)
  1: 5       Reps
  2: 1       SE Channel
  3: 1       Excite all reps w/E1
  4: 1       Loc [ Temp_1 ]
  5: 1.0     Mult
  6: 0.0     Offset

6: Beginning of Loop (P87)                  ;Master loop: end
  1: 0       Delay                       ;loop at step 30
  2: 5       Loop Count

;Start heater control logic
7: If (X<=>F) (P89)                         ;if temperature is below
  1: 1       -- X Loc [ Temp_1 ]          ;heater threshold
  2: 4       <
  3: 23.5    F
  4: 30      Then Do                     ;then

8: Z=F (P30)                                ;put a '1' into heater control
  1: 1       F                            ;location
  2: 0       Exponent of 10
  3: 10      -- Z Loc [ Heat_1 ]

9: End (P95)                                ;end 'then do'

10: If (X<=>F) (P89)                        ;if the heater is on (heater
  1: 10      -- X Loc [ Heat_1 ]         ;control location <>0)
  2: 2       <>
  3: 0       F
  4: 30      Then Do                     ;then

```

```

11: If (X<=>F) (P89)                                ;check upper threshold
1: 1          -- X Loc [ Temp_1 ]                   ;to see if heater should
2: 3          >=                                     ;be turned off
3: 25.5       F
4: 30         Then Do

12: Z=F (P30)                                        ;if heater should be turned
1: 0          F                                      ;off, enter a '0' into
2: 0          Exponent of 10                        ;heater control location
3: 10         -- Z Loc [ Heat_1 ]

13: End (P95)                                       ;end 'then do'

14: Else (P94)                                       ;else, if the heater is off

15: Z=F (P30)                                        ;enter a '0' into heater
1: 0          F                                      ;control location
2: 0          Exponent of 10
3: 10         -- Z Loc [ Heat_1 ]

16: End (P95)                                       ;end 'then do/else'

;End heater control logic
;Start cooler control logic

17: If (X<=>F) (P89)                                ;if 'cooler on' threshold
1: 1          -- X Loc [ Temp_1 ]                   ;is exceeded
2: 3          >=
3: 27.5       F
4: 30         Then Do                               ;then

18: Z=F (P30)                                        ;put a '1' into cooler
1: 1          F                                      ;control location
2: 0          Exponent of 10
3: 15         -- Z Loc [ Cool_1 ]

19: End (P95)                                       ;end 'then do'

20: If (X<=>F) (P89)                                ;if cooler is on (cooler
1: 15         -- X Loc [ Cool_1 ]                   ;control location <>0)
2: 2          <>
3: 0          F
4: 30         Then Do                               ;then

21: If (X<=>F) (P89)                                ;check lower threshold to
1: 1          -- X Loc [ Temp_1 ]                   ;see if cooler should be
2: 4          <                                     ;turned off
3: 24.5       F
4: 30         Then Do

22: Z=F (P30)                                        ;if cooler should be turned off
1: 0          F                                      ;put a '0' into cooler control
2: 0          Exponent of 10                        ;location
3: 15         -- Z Loc [ Cool_1 ]

```

```

23: End (P95) ;end 'then do'

24: Else (P94) ;else, if cooler is off

25: Z=F (P30) ;put a '0' into cooler
1: 0 F ;control location
2: 0 Exponent of 10
3: 15 -- Z Loc [ Cool_1 ]

26: End (P95) ;end 'then do/else'

;End cooler control logic
;Start fan control logic based on heater/cooler
27: If (X<=>F) (P89) ;if heater is on
1: 10 -- X Loc [ Heat_1 ]
2: 2 <>
3: 0 F
4: 11 Set Flag 1 High ;set flag 1

28: If (X<=>F) (P89) ;if cooler is on
1: 15 -- X Loc [ Cool_1 ]
2: 2 <>
3: 0 F
4: 11 Set Flag 1 High ;set flag 1

29: If Flag/Port (P91) ;if flag 1 is set
1: 11 Do if Flag 1 is High
2: 30 Then Do ;then

30: Z=F (P30) ;put a '1' into fan control
1: 1 F ;location
2: 0 Exponent of 10
3: 20 -- Z Loc [ Fan_1 ]

31: Else (P94) ;else, if flag 1 is reset

32: Z=F (P30) ;put a '0' into fan control
1: 0 F ;location
2: 0 Exponent of 10
3: 20 -- Z Loc [ Fan_1 ]

33: End (P95) ;end 'then do/else'

34: Do (P86) ;reset flag 1
1: 21 Set Flag 1 Low

35: End (P95) ;end master loop

;End fan control logic based on heater/cooler
;Start fan control logic based on time

```

```

36: If time is (P92)                                     ;if 5 minutes remain
   1: 10          Minutes (Seconds --) into a          ;out of 15 minute
   2: 15          Interval (same units as above)      ;interval
   3: 12          Set Flag 2 High                     ;set flag 2

37: If Flag/Port (P91)                                   ;if flag 2 is set
   1: 12          Do if Flag 2 is High
   2: 30          Then Do                             ;then

38: Beginning of Loop (P87)                             ;start fan loop
   1: 0          Delay
   2: 5          Loop Count

39: Z=F (P30)                                           ;put a '1' into fan control
   1: 1          F                                     ;location
   2: 0          Exponent of 10
   3: 20         -- Z Loc [ Fan_1 ]

40: End (P95)                                           ;end fan loop

41: End (P95)                                           ;end 'then do'

42: If time is (P92)                                   ;reset flag 2 at the
   1: 0          Minutes (Seconds --) into a          ;end of the 15 minutes
   2: 15          Interval (same units as above)
   3: 22          Set Flag 2 Low

;End fan control logic based on time
;Input locations 10 to 24 are now loaded
;with a '1' or '0' to set ports on the SDM-IO16

;Omit this instruction if using an older datalogger
;see below
43: SDM-IO16 (P188)
   1: 00          SDM Address
   2: 94          Command Code Option                 ;set the ports from locations
   3: 0000        Ports 16-13                         ;port settings not used for 94
   4: 0000        Ports 12-9
   5: 0000        Ports 8-5
   6: 0000        Ports 4-1
   7: 27          Return Code Loc [ ErrCount ]        ;for return code
   8: 10          First Loc [ Heat_1 ]                ;for control values
   9: 1.0         Mult
  10: 0.0         Offset

;Alternatively for older dataloggers P104 could be used
;Remove the above and uncomment this instruction
;43: SDM-CD16 (P104)                                   ;send instructions to the
;1: 1            Reps                                  ;SDM-IO16 with address 00
;2: 00          Address
;3: 10          Loc [ Heat_1 ]

```

```

*Table 2 Program
  02: 0.0000      Execution Interval (seconds)

*Table 3 Subroutines

End Program

```

7.3 A CR10X Program which Measures Four Frequency Inputs (Anemometers) and Four Switch Closure Inputs (Rain Gauges)

This program can also be used with a CR23X datalogger.

```

;{CR10X}
;An example that shows initial setup with frequency measurement
;on four ports and pulse counting, with switch closure, on the next
;four. In this example the four frequencies are anemometers and
;the switch closures are raingauges that need to be totalised
;
*Table 1 Program
  01: 5           Execution Interval (seconds)

;First configure the IO16 if not already done
;If flag 1 is not set, i.e. the program has just
;been compiled or datalogger powered up.
;This code is needed primarily to enable switch debounce filtering
;on channels 4..8

1: If Flag/Port (P91)
  1: 21           Do if Flag 1 is Low
  2: 30           Then Do

; Call instruction 188 to set the ports up
2: SDM-IO16 (P188)
  1: 0           SDM Address
  2: 90          Command Code Option      ;configure the ports
  3: 9999        Ports 16-13             ;Leave the last 8 ports as they are
  4: 9999        Ports 12-9
  5: 3333        Ports 8-5               ;Set ports 5..8 as switch closure
  6: 2222        Ports 4-1               ;Set ports 1..4 as normal inputs
  7: 1           Return Code Loc [ ErrCount ]
  8: 2           First Loc [ Windspd_1 ]
  9: 1.0         Mult
  10: 0.0        Offset

;Set flag 1 high to indicate we have run the setup code
3: Do (P86)
  1: 11          Set Flag 1 High

4: End (P95)                                         ; of IF block

```

```

;Measure the four frequencies and write to four input locations
;applying a scaling to m/s
5: SDM-IO16 (P188)
  1: 00          SDM Address
  2: 40          Command Code Option      ;read the freq of the signals on ports 1..4
  3: 0           Ports 16-13             ;port settings not used for 40
  4: 0           Ports 12-9
  5: 0           Ports 8-5
  6: 0           Ports 4-1
  7: 1           Return Code Loc [ ErrCount ] ;for return code
  8: 2           First Loc [ Windspd_1 ]   ;for first windspeed data
  9: .05148      Mult                    ;Calibration to give m/s for A100L2
 10: 0.0         Offset

;Measure the four pulses counts and write to four locations
;as equivalent rainfall in mm
6: SDM-IO16 (P188)
  1: 00          SDM Address
  2: 18          Command Code Option      ;Count the pulses on ports 5..8
  3: 0           Ports 16-13             ;port settings not used for 18
  4: 0           Ports 12-9
  5: 0           Ports 8-5
  6: 0           Ports 4-1
  7: 1           Return Code Loc [ ErrCount ] ;for return code
  8: 6           First Loc [ Rain_1 ]     ;for rain values
  9: 0.2         Mult                    ;Typical calib for mm per tip
 10: 0.0         Offset

;Example of output instructions
;Every hour
7: If time is (P92)
  1: 0           Minutes (Seconds --) into a
  2: 60          Interval (same units as above)
  3: 10          Set Output Flag High (Flag 0)

;Fix the array ID to 100
8: Set Active Storage Area (P80)
  1: 1           Final Storage Area 1
  2: 100         Array ID

;Store a time stamp first
9: Real Time (P77)
  1: 1110        Year,Day,Hour/Minute (midnight = 0000)

;Store average windspeeds
10: Average (P71)
  1: 4           Reps
  2: 2           Loc [ Windspd_1 ]

```

```

;Maximum windspeeds with time of maximum
11: Maximum (P73)
  1: 4          Reps
  2: 10         Value with Hr-Min
  3: 2          Loc [ Windspd_1 ]

;Totalize the rainfall over the previous hour
12: Totalize (P72)
  1: 4          Reps
  2: 6          Loc [ Rain_1 ]

*Table 2 Program
  02: 0.0000    Execution Interval (seconds)

*Table 3 Subroutines

End Program

```

7.4 A CR10X Program that uses the Interrupt Subroutine in the Datalogger to Record the Time of Change of any one of the Ports on an SDM-IO16

This program can also be used with a CR23X datalogger.

```

;{CR10X}
;An example that shows the use of the IO16 to detect the change
;of state of one of the 16 ports and indicate this to the
;datalogger using the I/O line (which should be connected to C8).
;The datalogger in turn reads the status and captures the
;current port status and writes this with a time stamp to memory
;
*Table 1 Program
  01: 5          Execution Interval (seconds)

;First configure the IO16 if not already done
;If flag 1 is not set, i.e. the program has just
;been compiled or datalogger powered up.
;This code is needed to set the IO16 to pulse its I/O line
;if any port changes state.
1: If Flag/Port (P91)
  1: 21          Do if Flag 1 is Low
  2: 30          Then Do

```

```

; Call instruction 188 to set the ports up
2: SDM-IO16 (P188)
  1: 00      SDM Address
  2: 90      Command Code Option
  3: 4444    Ports 16-13      ;configure the ports
  4: 4444    Ports 12-9      ;Set so all ports will cause an interrupt
  5: 4444    Ports 8-5
  6: 4444    Ports 4-1
  7: 1       Return Code Loc [ Errcount ] ;for return code
  8: 2       First Loc [ Portstat_]
  9: 1.0     Mult
 10: 0.0     Offset

;Set flag 1 high to indicate we have run the setup code
3: Do (P86)
  1: 11      Set Flag 1 High

4: End (P95) ; of IF block

;Now the rest of the other normal measurements would follow

*Table 2 Program
  02: 0.0000 Execution Interval (seconds)

*Table 3 Subroutines

;Subroutine 98 will be run when a signal is generated by the I/O line
;from the IO16 connected to C8 on the datalogger.
1: Beginning of Subroutine (P85)
  1: 98      Subroutine 98

;First read the port status from the IO16 as quickly as possible
;The speed at which the datalogger can respond to the I/O signal will
;determine the minimum pulse width that you can guarantee to capture
;as a change of state of a port. Typically this will be 10 ms but will
;vary with the datalogger and other activity.
;Reading the port status will cancel further polling
;until the next change of state.

  2: SDM-IO16 (P188)
    1: 00      SDM Address
    2: 91      Command Code Option      ;read the port status into one location
    3: 0       Ports 16-13      ;port settings not used for code 91
    4: 0       Ports 12-9
    5: 0       Ports 8-5
    6: 0       Ports 4-1
    7: 1       Return Code Loc [Errcount ] ;for return code
    8: 2       First Loc [Portstat ]
    9: 1.0     Mult
   10: 0.0     Offset

```

```
;Set the output flag to force immediate storage of data
3: Do (P86)
  1: 10          Set Output Flag High (Flag 0)

;Fix the array ID at 2000
4: Set Active Storage Area (P80)
  1: 1          Final Storage Area 1
  2: 200       Array ID

;Store the time now
5: Real Time (P77)
  1: 1111      Year,Day,Hour/Minute,Seconds (midnight = 0000)

;Switch to high resolution to ensure we can store the maximum value with
;full resolution, i.e. 5 digits for 65536
6: Resolution (P78)
  1: 1          High Resolution

;Sample the port status as a single binary value
7: Sample (P70)
  1: 1          Reps
  2: 2          Loc [ Portstat_ ]

8: End (P95)

End Program
```

Appendix A. General Principles of Pulse and Frequency Measurements

A.1 Introduction

It is necessary to understand the general method of input measurements of the SDM-IO16 to be able to easily comprehend the limits of frequency and duty cycle resolution.

The microprocessor in the module runs an internal task that reads the status of all 16 ports at a fixed frequency of 4096 Hz. Changes of state of each port from one sample to the next are used to determine the start and end of pulses. This sampling frequency determines the resolution and range of the pulse measurements.

A.2 Frequency and Duty Cycle Measurement Range

To guarantee that a pulse is detected it must last longer than the time between samples which is 244 μ s. This sets the upper limit of signal frequency for which pulses can be counted or frequencies measured. By implication, the maximum frequency that can be measured is with a 50/50 duty cycle signal. If the duty cycle is different from this, the maximum frequency measurable is lower. This maximum frequency, measurable for a signal with a range of duty cycles, can be expressed as the minimum of two functions:

$$f_{\max} = \%min * 4096 / 100 \quad (1)$$

$$f_{\max} = (100 - \%max) * 4096 / 100 \quad (2)$$

Where:

f_{\max} = maximum frequency at a specific duty cycle (Hz)

$\%min$ = minimum duty cycle in %

$\%max$ = maximum duty cycle in %

It also follows that for any given frequency (f) there will be a limit to the maximum and minimum duty cycle that can be measured due to the restriction of the minimum detectable pulse width. Using the same variables defined above,

$$\%min = f * 100 / 4096$$

$$\%max = 100 - \%min$$

It can be seen that the lower the frequency, the larger the measurable range of duty cycle.

A.3 Resolution of Frequency Measurements

The module measures frequency by counting the number of full signal cycles between requests for measurements by the datalogger and measuring the time between the start of the first and end of the last of these cycles. The resolution of a frequency measurement will be dependent on the number of pulses and the resolution of the internal timer (244 μ s). The resultant resolution can be calculated with the following equation:

$$f_{\text{res}} = f^2 / (4096 * \text{Int} (t * f))$$

Where:

f_{res} = resolution in (Hz).

f = actual frequency measured in (Hz).

t = time between frequency measurement commands in (seconds).

Int = a function which returns the truncated integer value.

For example, reading 1000 Hz at a 0.25 sec frequency measurement interval will give a resolution of 0.97 Hz, whilst at 1 sec between measurements the resolution would be 0.25 Hz.

The resolution improves with longer times between frequency measurement commands. However, the maximum time between measurements is 15.9375 seconds which is limited by the range of internal counters.

A.4 Resolution of Duty Cycle Measurements

Duty cycle measurements are made by calculating the proportion of time that a signal is high for all full signal cycles that occur in between two measurement requests by the datalogger. The resolution can be calculated using the following equation:

$$\%r = 100 * f / (4096 * \text{Int}(t * f))$$

Where:

$\%r$ = duty cycle resolution in (%)

f = frequency of the signal in (Hz)

t = time between duty cycle measurement commands in (seconds)

Int = a function which returns the truncated integer value.

For example reading the duty cycle of a 1000 Hz signal at 0.25 sec intervals will give a resolution of 0.097%, whilst at 1 second intervals the resolution would be 0.025%.

It can be seen that duty cycle resolution improves with longer times between duty cycle measurement commands. However, the maximum time between measurements is 15.9375 seconds which is limited by the range of internal counters.

Although the duty cycle measurement uses the same sampling frequency as the frequency measurement technique, it is not dependent on counting or timing a known number of cycles. For this reason, it is capable of sampling and giving

accurate duty cycle readings for higher frequency signals. Signals up to 4.000 kHz can be measured without error. Signals of higher frequency will also appear to give accurate measurements. Care should be taken as signals that are exact multiples of the sampler frequency, e.g. 4096, 8192 Hz will give completely spurious readings.

A.5 Debounce Filtering

The module is able to digitally filter input signals to prevent false counting of pulses or inaccurate measurement of frequency for signals sources that do not have "clean" digital signals. Such signals are often generated by mechanical switch closures where the contacts often bounce on changeover resulting in a signal that, for instance, goes low as the switch closes but then goes high for an instant as the contact bounces, before finally going low again when the switch finally closes properly.

The method of filtering switch bounce is also based on the 4096 Hz sampler. The principle of operation is that when the debounce time parameter is non-zero an integrator function is enabled for that port. Then when the signal is sampled, a counter is either increased or decreased depending on whether the signal is high or low. The counter value can range between two limits that represent the high or low input states. Only when the counter reaches the opposite extreme limit will a change of state be recognized. This action emulates a traditional 'RC' type of filter, except that the integrator changes in a linear fashion. The amount by which the counter is changed decreases with increasing size of the debounce timer parameter; i.e. the larger the parameter the slower the integration counter will change and the longer it will take for a change of state to be recognized.

This debounce time is the time a signal must stay in the new state before it will be recognized as having changed state. This is the minimum time it takes the internal counter to ramp from one limit to the other, providing the input signal switches cleanly from one state to the other. As with a traditional 'RC' filter, if the signal 'bounces' back to its old state, the integrator will ramp in the opposite direction during the bounce. This means that a new change of state will not be recognized until the filter time has passed plus twice the time period that the signal 'bounces' back to its original state.

As an example, a switch that changes state but bounces to its original state for a total of 0.5ms whilst changing will, with the default debounce time of 3.17ms, not be recognized as changing state until 4.17ms after the initial change. Only one pulse will be counted, though, even if the switch opened and closed several times within that 4.17ms period.

One consequence of this method of filtering is that the maximum frequency that can be measured is affected by the amount of switch bounce. In the example above, it takes 4.17ms to detect the initial changeover. The next change back to the original state cannot start until the end of this period otherwise the original changeover may not be counted. Assuming the same amount of bounce for all changeovers, the maximum frequency in this example would be $1/(0.00417*2)$, which equates to 120Hz, rather than 158 Hz if there is no bounce.

The relationship between the minimum debounce time in milliseconds (t_d) and the debounce parameter (n) is:

$$t_d = 0.244 + n * 0.244$$

The relationship between maximum frequency (f_{max}), debounce time and total switch bounce time (t_b) in milliseconds is:

$$f_{max} = 1000 / (2 * (t_d + 2 * t_b))$$

Appendix B. Command Code Listing

| Command | Action |
|---------|--|
| 1 | Read port 1 accumulated counts into 1 location |
| 2 | Read port 2 accumulated counts into 1 location |
| 3 | Read port 3 accumulated counts into 1 location |
| 4 | Read port 4 accumulated counts into 1 location |
| 5 | Read port 5 accumulated counts into 1 location |
| 6 | Read port 6 accumulated counts into 1 location |
| 7 | Read port 7 accumulated counts into 1 location |
| 8 | Read port 8 accumulated counts into 1 location |
| 9 | Read port 9 accumulated counts into 1 location |
| 10 | Read port 10 accumulated counts into 1 location |
| 11 | Read port 11 accumulated counts into 1 location |
| 12 | Read port 12 accumulated counts into 1 location |
| 13 | Read port 13 accumulated counts into 1 location |
| 14 | Read port 14 accumulated counts into 1 location |
| 15 | Read port 15 accumulated counts into 1 location |
| 16 | Read port 16 accumulated counts into 1 location |
| 17 | Read ports 1-4 accumulated counts into 4 locations |
| 18 | Read ports 5-8 accumulated counts into 4 locations |
| 19 | Read ports 9-12 accumulated counts into 4 locations |
| 20 | Read ports 13-16 accumulated counts into 4 locations |
| 21 | Read ports 1-8 accumulated counts into 8 locations |
| 22 | Read ports 9-16 accumulated counts into 8 locations |
| 23 | Read ports 1-16 accumulated counts into 16 locations |
| 24 | Read port 1 frequency into 1 location |
| 25 | Read port 2 frequency into 1 location |
| 26 | Read port 3 frequency into 1 location |
| 27 | Read port 4 frequency into 1 location |
| 28 | Read port 5 frequency into 1 location |
| 29 | Read port 6 frequency into 1 location |
| 30 | Read port 7 frequency into 1 location |
| 31 | Read port 8 frequency into 1 location |
| 32 | Read port 9 frequency into 1 location |
| 33 | Read port 10 frequency into 1 location |
| 34 | Read port 11 frequency into 1 location |
| 35 | Read port 12 frequency into 1 location |
| 36 | Read port 13 frequency into 1 location |
| 37 | Read port 14 frequency into 1 location |
| 38 | Read port 15 frequency into 1 location |
| 39 | Read port 16 frequency into 1 location |
| 40 | Read ports 1-4 frequency into 4 locations |
| 41 | Read ports 5-8 frequency into 4 locations |
| 42 | Read ports 9-12 frequency into 4 locations |
| 43 | Read ports 13-16 frequency into 4 locations |
| 44 | Read ports 1-8 frequency into 8 locations |
| 45 | Read ports 9-16 frequency into 8 locations |
| 46 | Read ports 1-16 frequency into 16 locations |
| 47 | Read port 1 duty cycle into 1 location |
| 48 | Read port 2 duty cycle into 1 location |
| 49 | Read port 3 duty cycle into 1 location |

Appendix B. Command Code Listing

| Command | Action |
|---------|---|
| 50 | Read port 4 duty cycle into 1 location |
| 51 | Read port 5 duty cycle into 1 location |
| 52 | Read port 6 duty cycle into 1 location |
| 53 | Read port 7 duty cycle into 1 location |
| 54 | Read port 8 duty cycle into 1 location |
| 55 | Read port 9 duty cycle into 1 location |
| 56 | Read port 10 duty cycle into 1 location |
| 57 | Read port 11 duty cycle into 1 location |
| 58 | Read port 12 duty cycle into 1 location |
| 59 | Read port 13 duty cycle into 1 location |
| 60 | Read port 14 duty cycle into 1 location |
| 61 | Read port 15 duty cycle into 1 location |
| 62 | Read port 16 duty cycle into 1 location |
| 63 | Read ports 1-4 duty cycle into 4 locations |
| 64 | Read ports 5-8 duty cycle into 4 locations |
| 65 | Read ports 9-12 duty cycle into 4 locations |
| 66 | Read ports 13-16 duty cycle into 4 locations |
| 67 | Read ports 1-8 duty cycle into 8 locations |
| 68 | Read ports 9-16 duty cycle into 8 locations |
| 69 | Read ports 1-16 duty cycle into 16 locations |
| 70 | Set port 1 debounce time from 1 location |
| 71 | Set port 2 debounce time from 1 location |
| 72 | Set port 3 debounce time from 1 location |
| 73 | Set port 4 debounce time from 1 location |
| 74 | Set port 5 debounce time from 1 location |
| 75 | Set port 6 debounce time from 1 location |
| 76 | Set port 7 debounce time from 1 location |
| 77 | Set port 8 debounce time from 1 location |
| 78 | Set port 9 debounce time from 1 location |
| 79 | Set port 10 debounce time from 1 location |
| 80 | Set port 11 debounce time from 1 location |
| 81 | Set port 12 debounce time from 1 location |
| 82 | Set port 13 debounce time from 1 location |
| 83 | Set port 14 debounce time from 1 location |
| 84 | Set port 15 debounce time from 1 location |
| 85 | Set port 16 debounce time from 1 location |
| 86 | Set port 16-13 from parameter 4 |
| 87 | Set port 12-9 from parameter 5 |
| 88 | Set port 8-5 from parameter 6 |
| 89 | Set port 4-1 from parameter 7 |
| 90 | Set port 16-1 from parameters 4-7 |
| 91 | Read state of ports 1-16 into 1 location. The location is a 16 bit decimal representation from 0-65535 |
| 92 | Read state of ports 1-16 into 16 locations. The first location is port 1 and the state is represented by 0 or 1 |
| 93 | Set state of ports 1-16 from 1 location. The location is a 16 bit decimal representation from 0-65535 |
| 94 | Set state of ports 1-16 from 16 locations. The first location is port 1 and the state is represented by 0 or 1 |
| 95 | Set direction of ports 1-16 from 1 location. The location is a 16 bit decimal representation from 0-65535 |
| 96 | Set direction of ports 1-16 from 16 locations. The first location is port 1 and the direction is represented by 0 or 1. |

| Command | Action |
|---------|--|
| 97 | Set interrupt mask of ports 1-16 from 1 location. The location is a 16 bit decimal representation from 0-65535 |
| 98 | Set interrupt mask of ports 1-16 from 16 locations. The first location is port 1 and the mask is represented by 0 or 1 |
| 99 | Read the OS signature, OS version and counters for watchdog resets and communication errors into 4 locations. Using this command also resets the counters. |

Campbell Scientific Companies

Campbell Scientific, Inc. (CSI)

815 West 1800 North
Logan, Utah 84321
UNITED STATES
www.campbellsci.com • info@campbellsci.com

Campbell Scientific Africa Pty. Ltd. (CSAf)

PO Box 2450
Somerset West 7129
SOUTH AFRICA
www.csafrica.co.za • cleroux@csafrica.co.za

Campbell Scientific Australia Pty. Ltd. (CSA)

PO Box 444
Thuringowa Central
QLD 4812 AUSTRALIA
www.campbellsci.com.au • info@campbellsci.com.au

Campbell Scientific do Brazil Ltda. (CSB)

Rua Luisa Crapsi Orsi, 15 Butantã
CEP: 005543-000 São Paulo SP BRAZIL
www.campbellsci.com.br • suporte@campbellsci.com.br

Campbell Scientific Canada Corp. (CSC)

11564 - 149th Street NW
Edmonton, Alberta T5M 1W7
CANADA
www.campbellsci.ca • dataloggers@campbellsci.ca

Campbell Scientific Centro Caribe S.A. (CSCC)

300 N Cementerio, Edificio Breller
Santo Domingo, Heredia 40305
COSTA RICA
www.campbellsci.cc • info@campbellsci.cc

Campbell Scientific Ltd. (CSL)

Campbell Park
80 Hathern Road
Shepshed, Loughborough LE12 9GX
UNITED KINGDOM
www.campbellsci.co.uk • sales@campbellsci.co.uk

Campbell Scientific Ltd. (France)

Miniparc du Verger - Bat. H
1, rue de Terre Neuve - Les Ulis
91967 COURTABOEUF CEDEX
FRANCE
www.campbellsci.fr • info@campbellsci.fr

Campbell Scientific Spain, S. L.

Psg. Font 14, local 8
08013 Barcelona
SPAIN
www.campbellsci.es • info@campbellsci.es

Please visit www.campbellsci.com to obtain contact information for your local US or International representative.