

**SC932 9-PIN TO RS-232-DCE INTERFACE
INSTRUCTION MANUAL**

REVISION: 01/04/03

COPYRIGHT (c) 1987-2003 CAMPBELL SCIENTIFIC, INC.

WARRANTY AND ASSISTANCE

The **SC932 9-PIN TO RS-232-DCE INTERFACE** is warranted by CAMPBELL SCIENTIFIC (CANADA) CORP. ("CSC") to be free from defects in materials and workmanship under normal use and service for **twelve (12) months** from date of shipment unless specified otherwise. CSC's obligation under this warranty is limited to repairing or replacing (at CSC's option) defective products. The customer shall assume all costs of removing, reinstalling, and shipping defective products to CSC. CSC will return such products by surface carrier prepaid. This warranty shall not apply to any CSC products which have been subjected to modification, misuse, neglect, accidents of nature, or shipping damage. This warranty is in lieu of all other warranties, expressed or implied, including warranties of merchantability or fitness for a particular purpose. CSC is not liable for special, indirect, incidental, or consequential damages.

Products may not be returned without prior authorization. To obtain a Return Merchandise Authorization (RMA), contact CAMPBELL SCIENTIFIC (CANADA) CORP., at (780) 454-2505. An RMA number will be issued in order to facilitate Repair Personnel in identifying an instrument upon arrival. Please write this number clearly on the outside of the shipping container. Include description of symptoms and all pertinent details.

CAMPBELL SCIENTIFIC (CANADA) CORP. does not accept collect calls.

Non-warranty products returned for repair should be accompanied by a purchase order to cover repair costs.



CAMPBELL SCIENTIFIC
C A N A D A C O R P .

11564 - 149 street - edmonton - alberta - T5M 1W7
tel 780.454.2505 fax 780.454.2655

www.campbellsci.ca

SC932 9-Pin to RS-232-DCE Interface

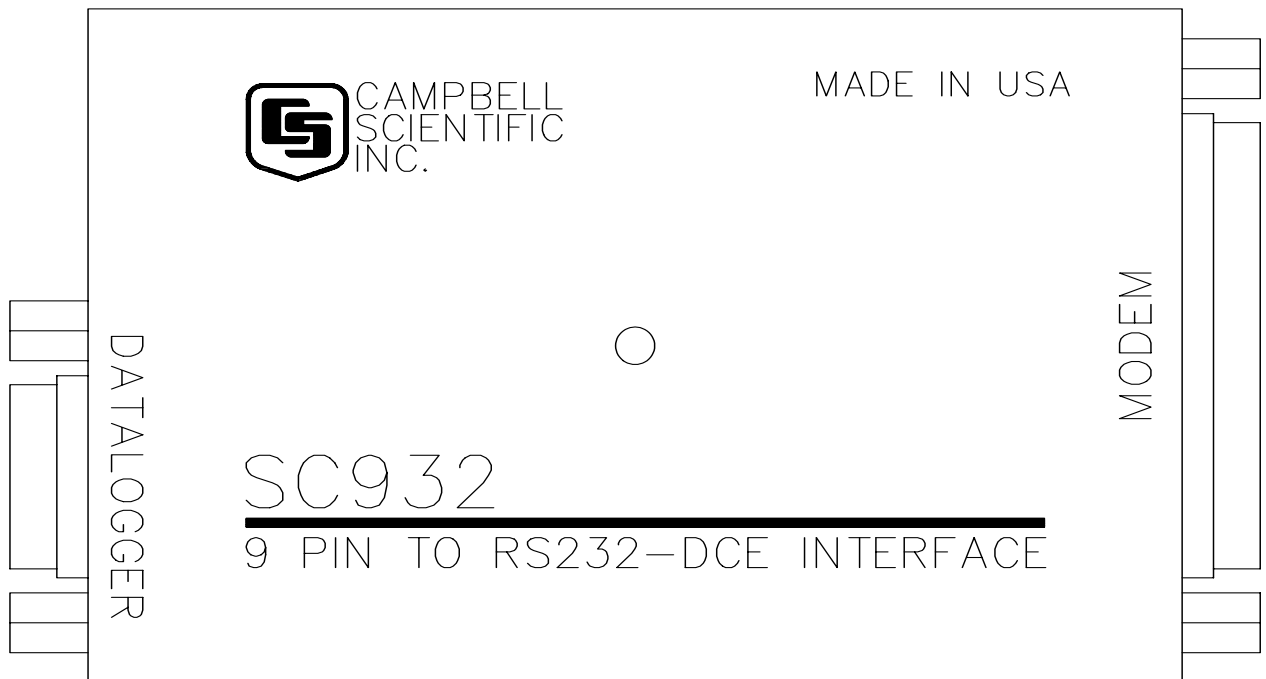

FIGURE 1. SC932 9-Pin to RS-232-DCE Interface

1. General Description

The SC932 (Figure 1) is used to interface a Campbell Scientific datalogger to any modem that is configured with an RS-232 DCE (Data Communications Equipment) serial port. Features include:

- True RS-232 signal levels.
- Power for the SC932 is supplied from the 5 V supply on pin 1 of the datalogger's I/O port. The SC932 will use the 5 V supply to power the RS-232 modem if needed.
- Power usage is jumper configurable for certain hardware configurations.
- Jumper selectable for two way (interactive) communication, one way (output or printer) communication, or both.

The SC932 is most frequently used with a short haul modem to communicate across a dedicated line made of 2 pairs of twisted wire with a shield. Section 3 describes the details of this application using a short haul modem built by RAD.

The SC932 is also commonly used with the satellite transmitters and spread spectrum radios.

2. Specifications

25 Pin Male Connector Pin-out:

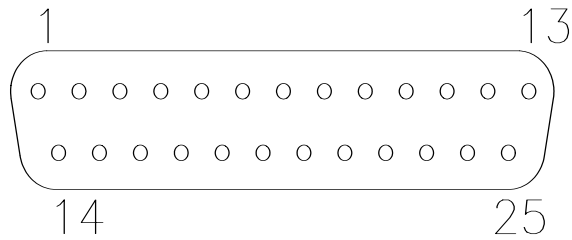

<u>Pin No.</u>	<u>I/O</u>	<u>Name</u>	<u>Description</u>
1		GND	Chassis Ground
2	out	TXD	SC932 transmits data on this line
3	in	RXD	SC932 receives data on this line
4	out	RTS	Held active by SC932 (see jumper description)
7		GND	Signal Ground
20	out	DTR	Held active by SC932 (see jumper description)
22	in	RING	Rings datalogger

9 Pin Male Connector Pin-out:

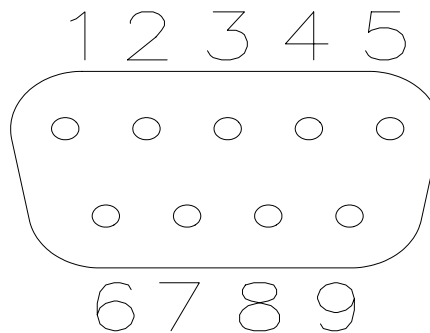

<u>Pin No.</u>	<u>I/O</u>	<u>Name</u>	<u>Description</u>
1	in	+5V	Regulated 5 Volt supply
2		GND	Ground
3	out	RING	Ring signal to datalogger
4	out	RXD	SC932 transmits on this line
5	in	ME	Modem Enable
6	in	SDE	Synchronous Device Enable
9	in	TXD	SC932 receives on this line

Data Rates

The SC932 will support baud rates up to 19,200 bps

Electrical

The SC932 uses power from the +5 V line on the 9 pin interface connected to the datalogger. The SC932 uses only a few microamps while inactive and about 5 mA when active from the 5 V supply. Additional current (up to 10 mA) from the 5 V supply may be used by the RS-232 device connected to the SC932.

Physical

Height: 1.0 in (25 mm)
Width: 3.5 in (90 mm)
Length: 4.1 in (103 mm)
Weight: 4.3 oz (123 g)
Mounting: 3 in by 3 in centered holes

Environmental

Temperature: -25 to +50°C
Humidity: up to 95% non-condensing

3. Installation

Proper transient protection should be installed to protect the computer and datalogger in areas where damage due to lightning is possible. If this is a RAD modem application, see Section 4.

3.1 Two Way Communication:

1. Remove the SC932 lid by removing the screw from the top of the box.
2. Jumper P3 between pins 1-2 (activated by Modem Enable) to set the SC932 for two way communication. See Figures 2 and 3.
3. Select the jumper configuration of P2 and P4 that will minimize power requirements and yet still allow the SC932 to function. There are three valid configurations of these jumpers. Having both P2 and P4 open will require the least power. Jumpering P4 only is the middle power level. Jumpering P2 only requires the most power. Modem devices which draw power from the SC932 interface usually require one of the higher power levels. If the RAD modem is being used, Section 4 describes the jumper settings to use.
4. Replace the lid.
5. Connect the SC932 to the RS-232 device and to the datalogger with the SC12 9 pin cable (included).

3.2 One Way Communication

1. Remove the SC932 lid by removing the screw from the top of the box.
2. Jumper P3 between pins 3-4 to set the SC932 to one way data only. The SC932 is activated by pin 6 synchronous device enable (SDE) on the datalogger's serial I/O port. See Figures 2 and 3.
3. Select the jumper configuration of P2 and P4 that will minimize power requirements and yet still allow the SC932 to function. There are three valid configurations of these jumpers. Having both P2 and P4 open will require the least power. Jumpering P4 only is the middle power level. Jumpering P2 only requires the most power. Modem devices which draw power from the SC932 interface usually require one of the higher power levels. If the RAD modem is being used, Section 4 describes the jumper settings to use.
4. Replace the lid.
5. Connect the SC932 to the RS-232 device and to the datalogger with the SC12 9 pin cable (included).

3.3 Two Way or One Way Communication

1. Remove the SC932 lid by removing the screw from the top of the box.
2. Jumper P3 between pins 1-2 and between pins 3-4 to set the SC932 for two way or one way telecommunications. See Figures 2 and 3.
3. Select the jumper configuration of P2 and P4 that will minimize power requirements and yet still allow the SC932 to function. There are three valid configurations of these jumpers. Having both P2 and P4 open will require the least power. Jumpering P4 only is the middle power level. Jumpering P2 only requires the most power. Modem devices which draw power from the SC932 interface usually require one of the higher power levels. If the RAD modem is being used, Section 4 describes the jumper settings to use.
4. Replace the lid.
5. Connect the SC932 to the RS-232 device and to the datalogger with the SC12 9 pin cable (included).

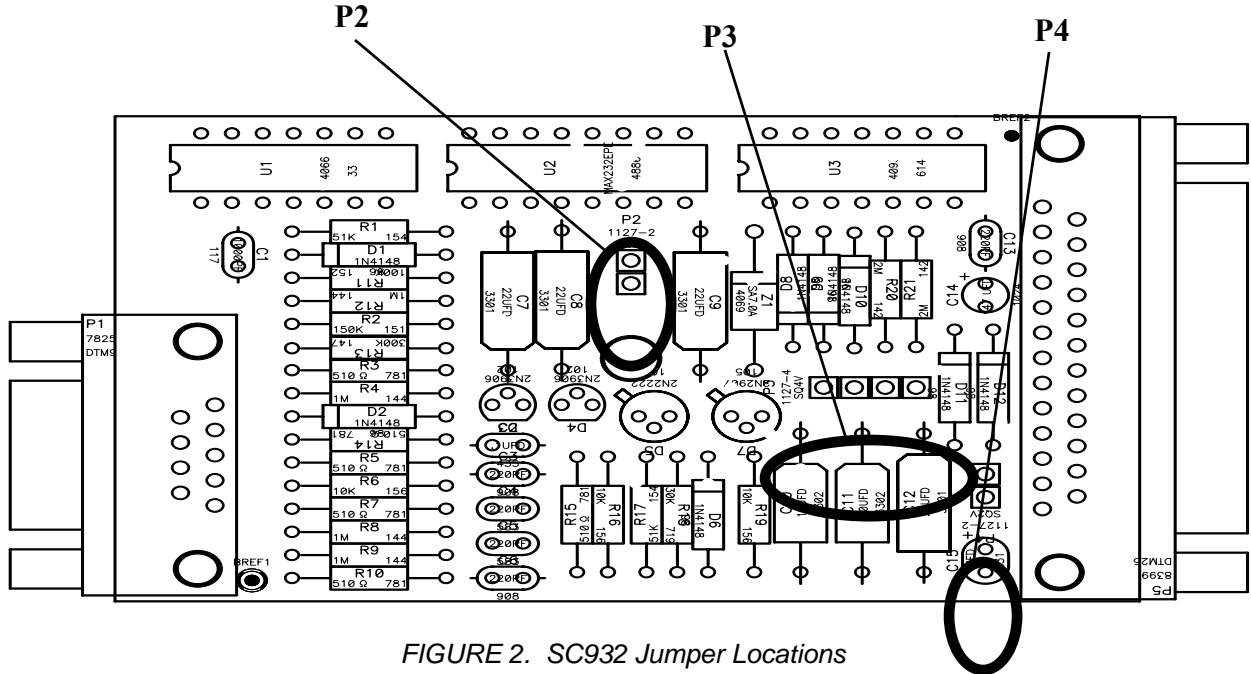

FIGURE 2. SC932 Jumper Locations

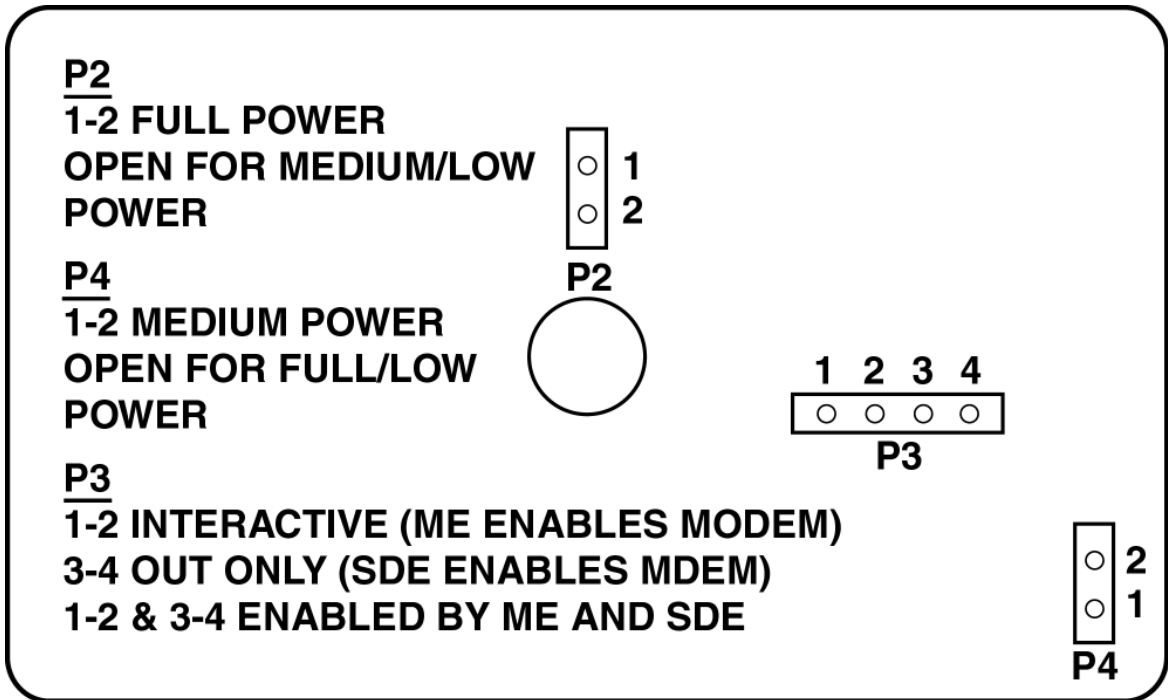

FIGURE 3. SC932 Jumper Descriptions

3.4 Jumper Descriptions

The following guidelines are used to determine the proper jumper configuration for the modem being used. When selecting a jumper configuration always try to keep current drain to a minimum.

<u>Current Drain</u>	<u>Jumper</u>	<u>Position</u>	<u>Description</u>
	P3	1-2	Allows SC932 to act as a Datalogger Modem device (two way communication). SC932 is activated by modem enable (ME) line.
		3-4	Allows SC932 to act as a Datalogger Printer device (one way). SC932 is activated by pin 6 synchronous device enable (SDE) on the datalogger's Serial I/O port.
		1-2 3-4	Allows SC932 to act as both of the above. The one way data mode resumes once the modem enable (ME) is dropped. The ME line is dropped when the two way communication is shut down or after 40 seconds of inactivity.
LO	P2	Open	
	P4	Open	DTR and RTS are held at 9V while the SC932 is active. They are not driven while the SC932 is not active. This jumper selection should be used when the SC932 is being used for Printer data or when the RS-232 device connected to the SC932 can produce a ring or RXD signal while DTR, RTS, and TXD are not powered (e.g. Hayes Modem).
MEDIUM	P2	Open	
	P4	Installed	DTR and RTS are held at 4.3V while the SC932 is not active and 9V while active. This jumper selection should be used when the RS-232 device connected to the SC932 can produce a ring or RXD signal when DTR and RTS are at 4.3V and TXD is not driven. This configuration will take more power than when both P2 and P4 are open depending on the RS-232 device (e.g. RAD modems).
HIGH	P2	Installed	
	P4	Open	DTR and RTS are held at 9V all the time. This configuration takes the most power, and provides fully active RS-232 signals on the DTR, RTS, and TXD lines all the time. Any RS-232 compatible device should work with this jumper selection.

4. RAD Modem Application

The SC932 is most frequently used with a short range modem to communicate across a 4-wire, unconditioned dedicated line. This section describes the details of this application using a short range asynchronous modem built by RAD*.

* SRM - 5A RAD Modem
 RAD Data Communications Inc.
 900 Corporate Drive
 Mahwah, NJ 07430
 Tel: (201) 529-1100
 Fax: (201) 529-5777
 Email: market@radusa.com
 http://www.rad.com

For transmission, the RAD modem uses a cable made of 2 pairs of twisted wires with a shield. Data rates up to 9600 bps are possible. The low voltage transmission levels minimize cross-talk between adjacent lines within the same cable. Data are transmitted and received at a balanced impedance, providing excellent immunity to circuit noise. Table 1 gives the data rate possible for several gauge cables across several distances.

Data Rate bps	19 Gauge (0.9 mm)		24 Gauge (0.5 mm)		26 Gauge (0.4 mm)	
	miles	km	miles	km	miles	km
9,600	6.2	10.0	2.8	4.5	2.0	3.3
1,200	7.6	12.2	3.4	5.5	2.5	4.0

Figures 4, 5, and 6 show specific jumper settings for three applications with the RAD Modem. Figure 4 is an example of two way communication with a computer, Figure 5 shows one way communication to a printer or display, and Figure 6 shows both. Note the differences in jumper settings.

4.1 RAD Modem - Two Way

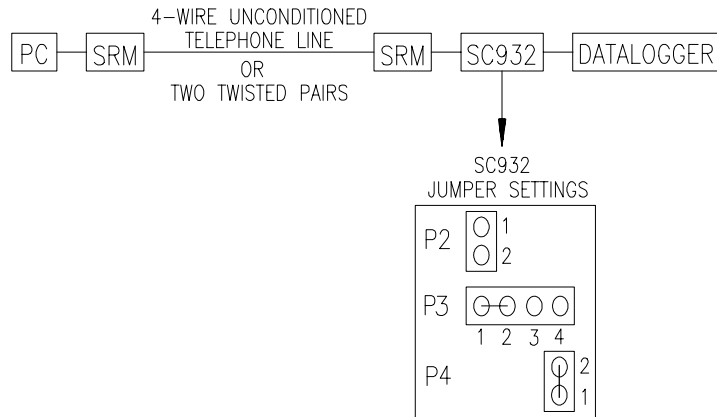

FIGURE 4. Two Way Communication

The SC932 leaves the factory with the jumpers set as shown in Figure 4. In this mode, the SC932 and RAD modem combined will require about 2 mA while inactive and less than 20 mA while active. When using Campbell Scientific's PC208W telecommunications software to communicate through the SC932/RAD modem, "Setup" the link as a direct connect between the datalogger and the desired COM port. Start two way communication using the "Connect" button on the Tool bar and the "Connect" button in the "Connect" window.

4.2 RAD Modem - One Way

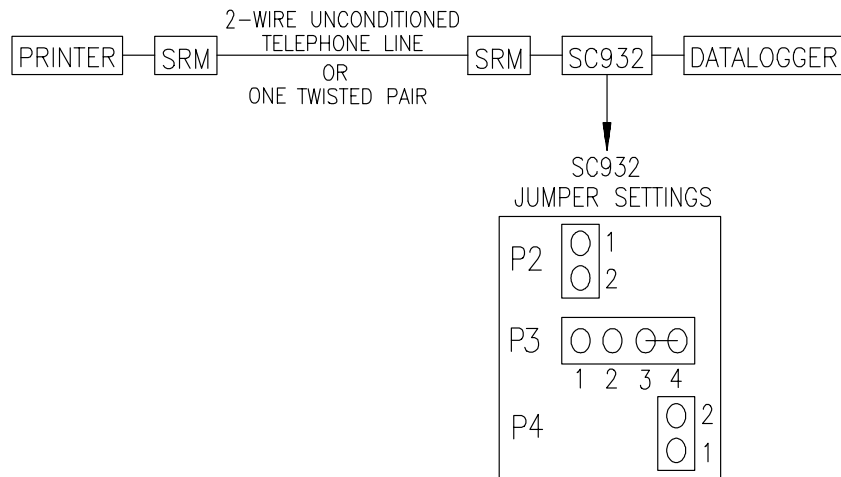

FIGURE 5. One Way Communication

In this mode, the SC932 and RAD modem combined will require about 2 mA while inactive and less than 20 mA while active.

Use Instruction 96 in the datalogger to output data to a printer or display. The bit rate, parity, start and stop bits must be the same in the datalogger and the display/printer. The datalogger sends the data as 8 data bits, no parity, 1 start bit and 1 stop bit. When using Campbell Scientific's PC208W telecommunications software to display "printer" data sent by the datalogger "Setup" the link as a direct connect between the datalogger and the desired COM port. Start one way communication using the "Connect" button on the Tool bar, the "Terminal" tab, and the "Open Port" button in the "Terminal" tab. Wait for the data to be displayed.

NOTE

Only one twisted pair is required for one way communication. Refer to RAD manual for wire connections.

4.3 RAD Modem - Two Way or One Way

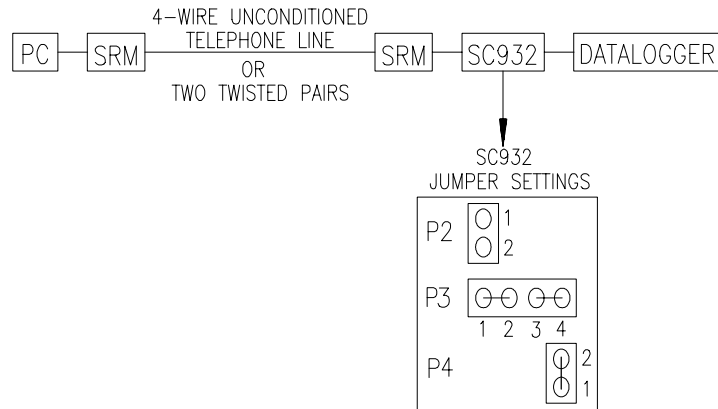

FIGURE 6. Two Way or One Way Communication

In the jumper configuration shown in Figure 6, the communication mode, two way or one way is determined by the modem enable line. Communication is two way if the modem enable line is high, one way if modem enable is low. In this mode, the SC932 and RAD modem combined will require about 2 mA while inactive and less than 20 mA while active.

Two way setup and connect: same as two way only. One way setup and connect: same as one way only.

4.4 RAD Modem Wiring and Grounding

Figure 7 shows a typical setup of the RAD modems. Installation is as follows:

1. Set the DCE/DTE switch on the back of the RAD modem connected to the SC932 to DCE. For a RAD modem connected to a PC, set the DCE/DTE switch to DCE. For a RAD modem connected to a serial printer, set the DCE/DTE switch to DTE.
2. Select a cable with two or more twisted pairs that will meet the demands of the environment where the system is to be installed.
3. Wiring connections are made as shown in Figure 7. Note wires labeled A and B are one twisted pair of the cable. Wires labeled C and D are the other twisted pair.
4. Transients induced on the communication line may damage any electronics connected at either end of the line. To decrease the chances for damage, spark gaps should be installed as shown in Figure 7. The transient protection shown may be purchased from Campbell Scientific (PN L6536-10 shown in Figure 7, PN L6536 includes a plastic case). Model SRM-C is a cable assembly that simplifies the connections between the RAD modems and the transient protection. Spark gap wiring is straight through such that pin to pin continuity exists between the two

modems. If the modems are installed entirely within a building, the transient spark gap protection is probably not needed.

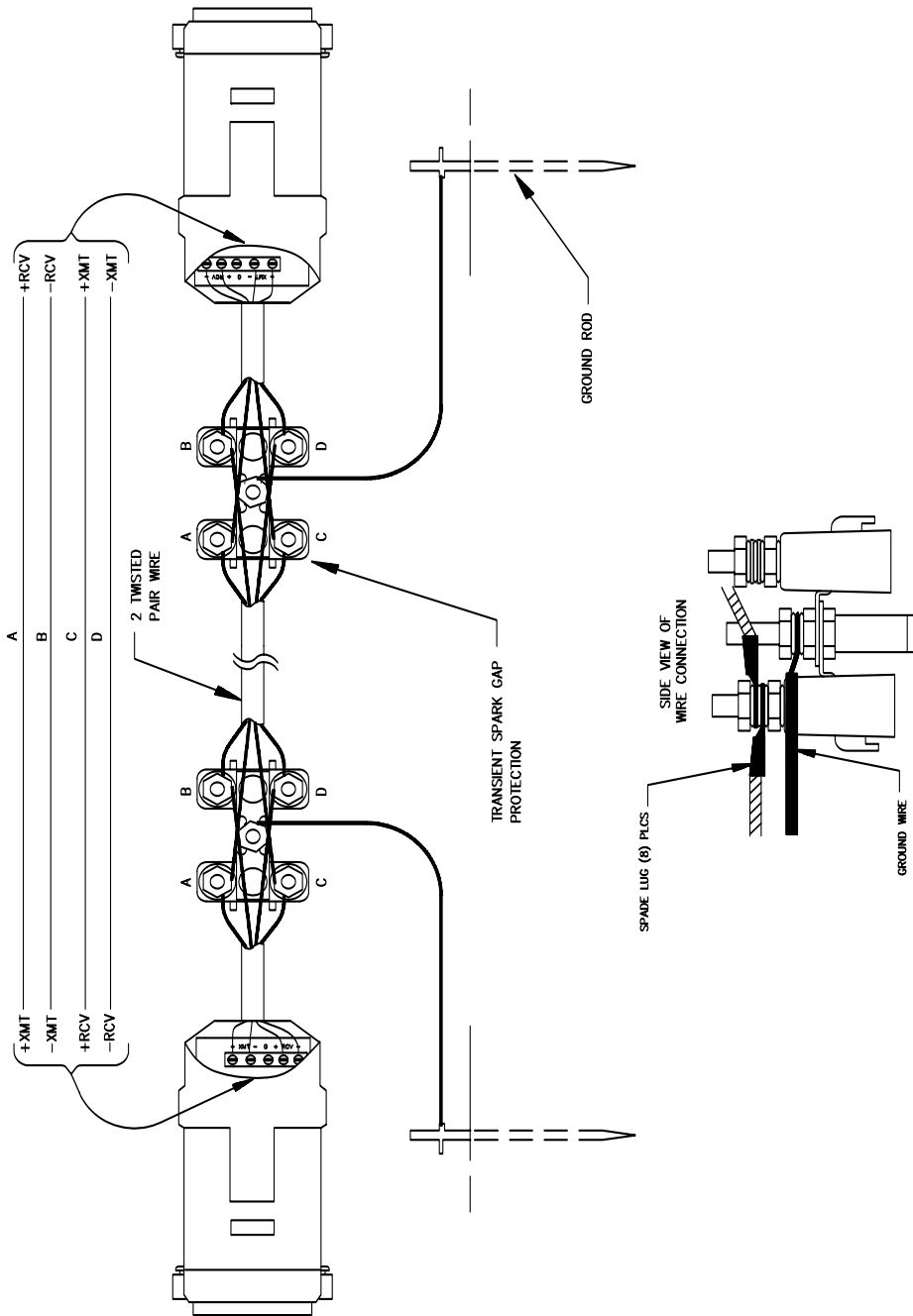

FIGURE 7. Installation of Spark Gap Protection

Occasionally a customer needs to transmit data across longer or smaller gauge wires or at higher speeds than can be done with the RAD modem powered by the SC932. RAD does sell a 9 volt power supply that will boost the signals enough to meet some of these more demanding applications. Please contact RAD for more information.

4.5 Testing RAD Modem Communication

The modem communication link is divided into the following three sections: 1) RAD modem computer end, 2) cable from computer modem to datalogger modem, 3) RAD modem datalogger end. When unable to establish communication with the datalogger, test each of the three sections.

Before proceeding through the testing procedures, a terminal emulator software program such as "KERMIT", "PROCOMM", or Campbell Scientific's PC208W (Remote Keyboard Display Terminal) must be used to communicate through the COM port of the computer. Once the emulator program is set up, testing can proceed as follows:

1. Disconnect the 4 conductor cables from the SRM-6A RAD modem at the computer end. Jumper the XMT + to RCV + and jumper the XMT - to RCV -. This creates a transmit loop which allows any key pressed at the computer keyboard to be seen on the screen. If the key pressed is not seen, check the following: COM port configuration, 25 pin cable from the computer to the modem and the RAD modem.
2. Reconnect the 4 conductor cables to the modem at the computer end and disconnect the cable from the modem at the datalogger end. Twist together the XMT + wire and RCV + wire, twist together the XMT - wire and the RCV - wire. Repeat the process of step 1 by pressing a key on the computer keyboard. If the key pressed is not returned, then the cable from the modem at the computer to the datalogger modem is defective and will need to be repaired or replaced.
3. If steps 1 and 2 pass, the modem at the datalogger is suspect. Disconnect the modem from the SC932 and bring the modem to the computer site. Attach the modem to the computer, and repeat step 1 by jumpering the terminals of the modem and pressing a key on the computer keyboard.

If the above tests pass and communication to the datalogger still has not been established, perform tests 4, 5, and 6.

4. A 12 V lead acid battery supply should not be discharged below 11.76 V. If this occurs, the batteries will go into a deep discharge state and will need to be replaced. The CR10 will function properly on a battery voltage of 10 to 15 volts. Check the 12 V supply with a volt meter.
5. On the wiring panel of most Campbell Scientific dataloggers there is a terminal marked 5 V. Check the 5 V supply with a volt meter. This 5 V supply should be within a tenth of a volt. If not, it would indicate a problem.

6. To verify that the datalogger and its serial I/O port are working, try to access input memory locations using a laptop PC with the SC32B or the CR10KD Keyboard Display.

If the datalogger passes tests 4, 5, and 6, then the SC932 is suspect and will need to be repaired or replaced.