

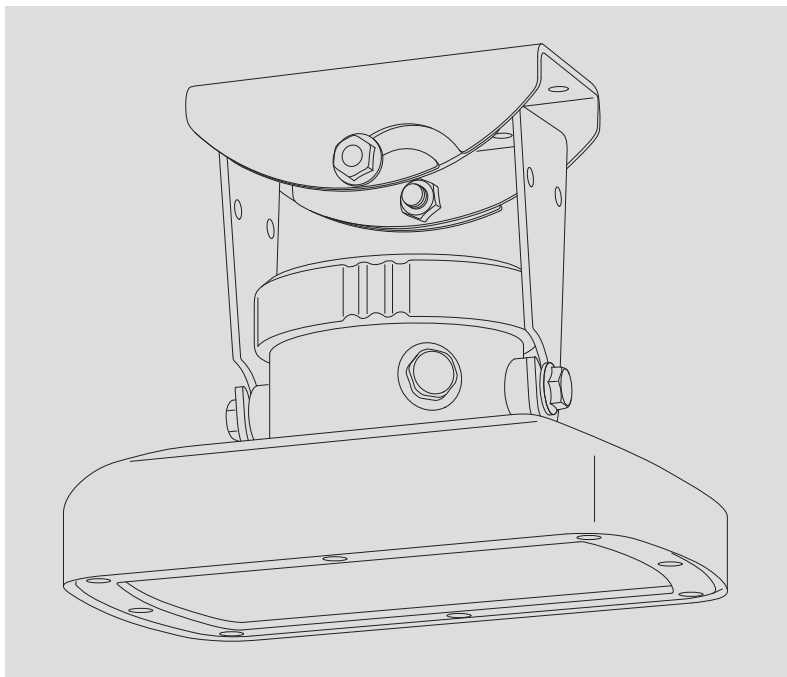

Operating instructions  
**Radar Level Sensor**  
**OTT RLS**



English

These operating instructions, version *04-0309*, cover the OTT RLS firmware from V 1.11.0 (production date: as of July 2009).

The current firmware version can be determined with the SDI-12 command `a00v!`. If the OTT RLS is in its delivered state, the firmware version can also be found in the factory acceptance test certificate supplied.

**Caution:** firmware version V 1.11.0 introduced new SDI-12 commands and existing commands were changed. If an OTT RLS with firmware V 1.11.0 or newer is exchanged for an older device, the configuration of the datalogger must be checked, and changed if necessary. Please take note of Chapter 6!

We reserve the right to make technical changes and improvements without notice.

## WARRANTY AND ASSISTANCE

This equipment is warranted by CAMPBELL SCIENTIFIC (CANADA) CORP. ("CSC") to be free from defects in materials and workmanship under normal use and service for **twelve (12) months** from date of shipment unless specified otherwise. \*\*\*\*\* **Batteries are not warranted.** \*\*\*\*\* CSC's obligation under this warranty is limited to repairing or replacing (at CSC's option) defective products. The customer shall assume all costs of removing, reinstalling, and shipping defective products to CSC. CSC will return such products by surface carrier prepaid. This warranty shall not apply to any CSC products which have been subjected to modification, misuse, neglect, accidents of nature, or shipping damage. This warranty is in lieu of all other warranties, expressed or implied, including warranties of merchantability or fitness for a particular purpose. CSC is not liable for special, indirect, incidental, or consequential damages.

Products may not be returned without prior authorization. To obtain a Return Merchandise Authorization (RMA), contact CAMPBELL SCIENTIFIC (CANADA) CORP., at (780) 454-2505. An RMA number will be issued in order to facilitate Repair Personnel in identifying an instrument upon arrival. Please write this number clearly on the outside of the shipping container. Include description of symptoms and all pertinent details.

CAMPBELL SCIENTIFIC (CANADA) CORP. does not accept collect calls.

Non-warranty products returned for repair should be accompanied by a purchase order to cover repair costs.



**CAMPBELL SCIENTIFIC**  
C A N A D A C O R P .

11564 - 149 street - edmonton - alberta - T5M 1W7  
tel 780.454.2505 fax 780.454.2655

[www.campbellsci.ca](http://www.campbellsci.ca)

## Table of contents

<b>1 Scope of supply</b> .....	4
<b>2 Order numbers</b> .....	4
<b>3 Basic safety information</b> .....	5
<b>4 Introduction</b> .....	6
<b>5 Installing the OTT RLS</b> .....	8
5.1 Criteria for selecting a suitable mounting location .....	8
5.2 Notes on power supply .....	9
5.3 Suitable cable types when using the RS-485 interface .....	9
5.4 Mounting the OTT RLS .....	9
5.5 Connecting the OTT RLS to any datalogger using an SDI-12 interface .....	11
5.6 Connecting the OTT RLS to any datalogger using a 4 ... 20 mA interface .....	12
5.7 Determining the maximum load resistance at the 4 ... 20 mA interface .....	12
5.8 Notes on using the 4 ... 20 mA interface .....	13
5.9 Note on using the RS-485 interface .....	13
<b>6 SDI-12 commands and responses</b> .....	14
6.1 Standard commands .....	14
6.2 Advanced SDI-12 commands .....	15
<b>7 Carrying out maintenance work</b> .....	20
<b>8 Repair</b> .....	20
<b>9 Troubleshooting</b> .....	21
<b>10 Note about the disposal of old units</b> .....	22
<b>11 Technical Data</b> .....	23
<b>Annex A – Connecting the OTT RLS to LogoSens 2 or DuoSens     using an SDI-12 or RS-485 interface</b> .....	25
<b>Annex B – Connecting the OTT RLS to LogoSens 2 or DuoSens     using a 4 ... 20 mA interface</b> .....	28
<b>Annex C – Dimensions of wall bracket/position of fixing bores</b> .....	30
<b>Annex D – Declaration of Conformity</b> .....	31
<b>Annex E – Radio Approval USA: <i>Grant of Equipment Authorization</i></b> .....	32
<b>Annex F – Radio Approval Canada: <i>Technical Approval Certificate</i></b> .....	33
Annex G - RLS Sensor Wiring Terminal Connections to Datalogger using FIN4COND-L .....	34

## 1 Scope of supply

- ▶ **OTT RLS**
  - 1 Radar sensor OTT RLS, two part swivel mount (consisting of device and wall brackets with 4 M8 Allen bolts)
  - 1 Installation kit (4 x wood screws 6 x 40 mm; 4 x plastic plugs S8)
  - 2 Double open-ended wrenches size 10 x 13
  - 1 Operating instructions
  - 1 Factory acceptance test certificate (FAT)

## 2 Order numbers

- ▶ **OTT RLS**
  - Radar sensor OTT RLS** 63.105.001.9.2
    - Version 4: RS-485 + 4 ... 20 mA interface
    - Version S: SDI-12 + 4 ... 20 mA interface
- ▶ **Accessories**
  - Connection cable** 97.000.039.9.5
    - twisted-pair design
    - PVC, black
    - 2 x 2 x 0,5 mm<sup>2</sup>
    - approx. AWG 22 (7 x AWG 30)
  - Connection cable** 97.000.040.9.5
    - twisted-pair design
    - PVC, black
    - 2 x 2 x 0,75 mm<sup>2</sup>
    - AWG 20 (7 x AWG 28)
  - OTT RLS bridge mounting** 63.105.025.3.2
    - Mounting aid for attaching the OTT RLS to a bridge
    - For side mounting
    - Height according to customer requirements
    - Distance to bridge according to customer requirements
  - Angle bracket** 63.105.026.3.2
    - For attaching the OTT RLS bridge mounting from above
  - OTT USB/SDI-12 Interface** 65.050.001.9.2
    - For temporarily connecting OTT sensors to a PC with SDI-12 or RS-485 interface
    - Including 1 USB connection cable. USB connector type A to USB type B; 3 m

### 3 Basic safety information



- ▶ Read these operating instructions before using the OTT RLS for the first time! Make yourself completely familiar with the installation and operation of the OTT RLS! Retain these operating instructions for later reference.
- ▶ The OTT RLS is used for contactless level measurement of surface waters. Only use the OTT RLS in the manner described in these operating instructions! For further information → see Chapter 4, *Introduction*.
- ▶ Note all the detailed safety information given within the individual work steps. All safety information in these operating instructions are identified with the warning symbol shown here.
- ▶ Never use the OTT RLS in areas where there is a danger of explosion. For further information → see Chapter 5, *Installing the OTT RLS*.
- ▶ Note that the electric installation of the OTT RLS may only be done by a professional. For further information → see Chapter 5, *Installing the OTT RLS*.
- ▶ Protect the power supply connection with a fuse (2.5 ampere, blowing speed: fast). For further information → see Chapter 5, *Installing the OTT RLS*.
- ▶ It is essential to comply with the electrical, mechanical and climatic specifications given in the Technical Data section. For further information → see Chapter 11, *Technical data*.
- ▶ Do not make any changes or retrofits to the OTT RLS. If changes or retrofits are made, all guarantee claims are voided. Furthermore, the radio approval required for its operation is void!
- ▶ Have a faulty OTT RLS inspected and repaired by our repair center. Never make any repairs yourself under any circumstances. For further information → see Chapter 8, *Repair*.
- ▶ Dispose of the OTT RLS properly after taking out of service. Never put the OTT RLS into the normal household waste. For further information → see Chapter 10, *Note about the disposal of old units*.

#### **Federal Communications Commission (FCC) Approval**

Note: This equipment has been tested and found to comply with the limits for a Class A digital device, pursuant to part 15 of the FCC Rules. These limits are designed to provide reasonable protection against harmful interference when the equipment is operated in a commercial environment. This equipment generates, uses, and can radiate radio frequency energy and, if not installed and used in accordance with the instruction manual, may cause harmful interference to radio communications. Operation of this equipment in a residential area is likely to cause harmful interference in which case the user will be required to correct the interference at his own expense.

#### **Industry Canada Approval**

This Class A digital apparatus complies with Canadian ICES-003.  
Cet appareil numérique de la classe A est conforme à la norme NMB-003 du Canada.

## 4 Introduction

The OTT RLS radar sensor is used for contactless measurement of the levels of surface water.

The OTT RLS is based on impulse radar technology. The transmitting antenna transmits short radar pulses in the 24 GHz ISM band. The separate receiver antenna receives the pulses reflected from the water and uses them to determine the distance between sensor and water surface: the time taken by the radar pulses from transmission to reception is proportional to the distance between sensor and water surface. The actual water level of the waterway is then calculated automatically, if required, by the radar sensor. To do this, on initial startup there is the possibility of inputting the relevant measurement mode and a reference value.

Three standardized electrical interfaces are available for connecting the OTT RLS to a datalogger or peripheral devices (depending on the version of the device): 4 ... 20 mA, SDI-12 and RS-485 (SDI-12 protocol).

The radar sensor can be configured via the SDI-12 transparent mode of a datalogger or via the OTT USB/SDI-12 interface (accessory - SDI-12/RS-485 interface). When using the 4 ... 20 mA interface, it is possible to scale the measurement output to a smaller measuring range.

The transmission antenna has a beam width of approx. 12°. The resulting sensor beam can be seen in the depiction in Figures 2 and 3 and the table in Chapter 5.1.

The OTT RLS includes a swivel mount that allows the sensor housing to be mounted parallel (longitudinal and lateral axis) with the water surface, even when the sensor is mounted on a slanted surface. A waterproof terminal area can be found under a removable screw cover for attaching the sensor cable.

If the RS-485 interface is used, the length of cable between radar sensor and datalogger can amount up to 1000 meters · 3,300 ft. Using the SDI-12 interface, the maximum length of cable is 100 m · 330 ft.

Provided that the unit has been mounted correctly according to the operating instructions, the complete radar sensor is flooding proof with IP 67 rating (diving bell principle).

Fig. 1: Overview of radar sensor OTT RLS.

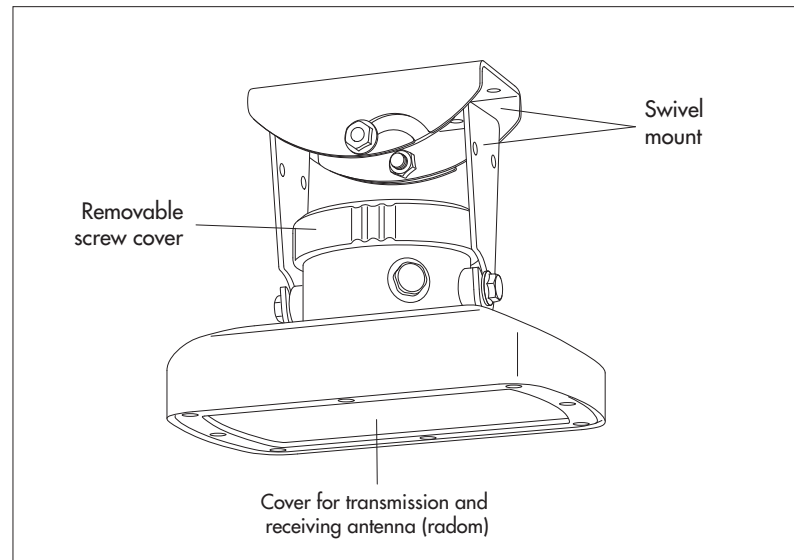

Fig. 2: Application example 1:  
Mounting the OTT RLS on a bridge.  
The projection of the sensor beam onto  
the water surface is virtually round.

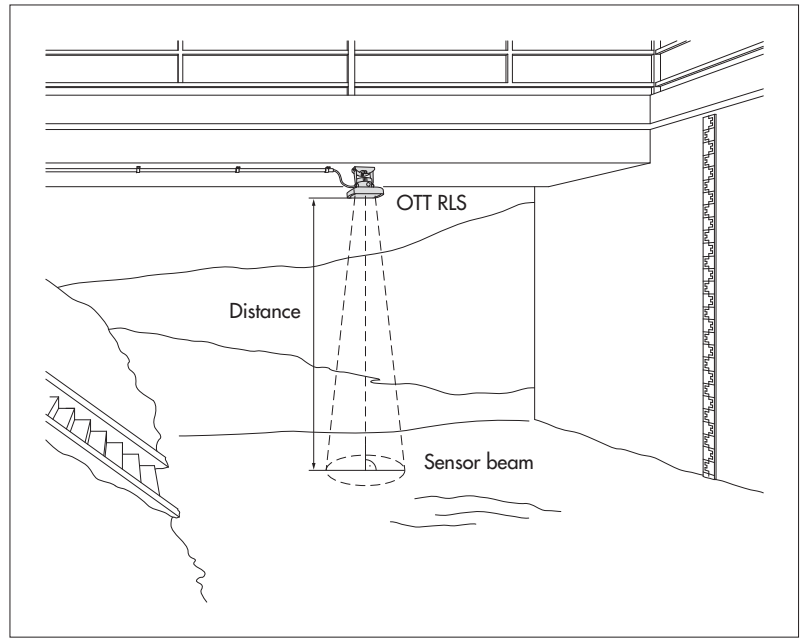
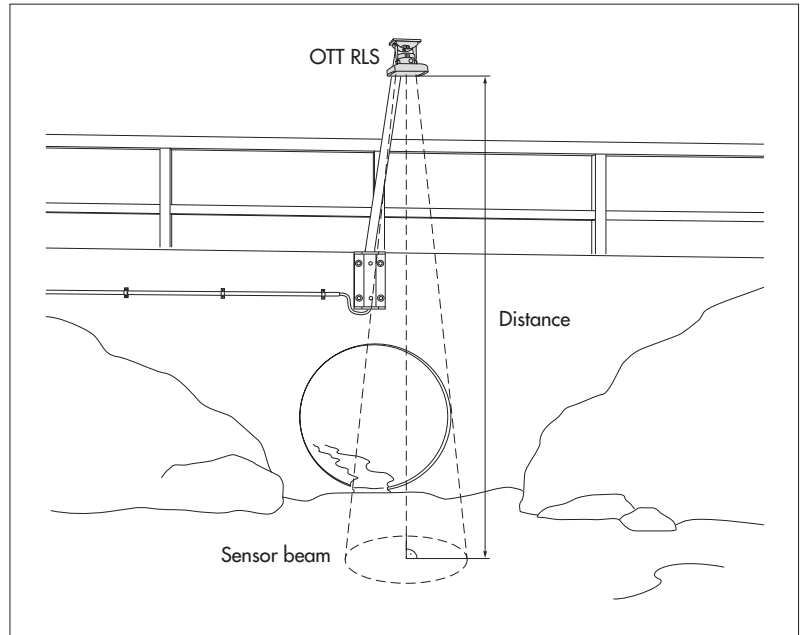

Fig. 3: Application example 2:  
Mounting the OTT RLS on an  
auxiliary construction, e.g. metal  
stand with mounting plate.



## 5 Installing the OTT RLS

**Caution:** The electrical installation of the OTT RLS may only be undertaken by qualified persons (e.g. a specially trained electrician)!

### 5.1 Criteria for selecting a suitable mounting location

- ▶ Possible mounting locations are, for example, bridges and auxiliary constructions directly above the waterway section to be measured.
- ▶ The minimum distance between lower edge of the sensor and water surface must be 0.8 m · 2.6 ft (dead area in which no useable measurement is possible).
- ▶ Select a mounting point high enough so that measurement is possible even with high water levels.
- ▶ The mounting point must be steady. Vibrations and movement of the mounting point must be avoided. Bridges are affected by movements of several centimeters as a result of load changes and temperature movements. If pillars are available, the sensor can be mounted to a stable positioned pillar with a suitable spacer.
- ▶ The water surface must be as smooth as possible in the area of the sensor beam. Avoid turbulent areas, areas where foam is created, surge areas and waterway sections where obstructions or bridge piers cause changes in the water level. The measurement result cannot be used if there is ice or snow on the water surface!
- ▶ Choose a mounting location that does not become dry at low water levels.
- ▶ Stations subject to very rapid changes in water level are not suitable. The OTT RLS averages its measurement result over a measuring time of approx. 20 seconds.
- ▶ The area within the sensor beam (see Figures 2 and 3) must be completely free of obstructions. Table for approximating the size of the sensor beam:

Distance OTT RLS – water surface		Diameter sensor beam	
5 m	16.5 ft	1.06 m	3.5 ft
10 m	33.0 ft	2.12 m	7.0 ft
15 m	49.0 ft	3.19 m	10.5 ft
20 m	66.0 ft	4.25 m	14.0 ft
25 m	82.0 ft	5.31 m	17.5 ft
30 m	98.0 ft	6.38 m	21.0 ft
35 m	115.0 ft	7.44 m	24.5 ft

The diameters given are minimum sizes. Where possible, select an area free of obstruction that is clearly larger.

- ▶ Avoid large metal surfaces near the sensor beam (reflections from these surfaces can distort the measurement result).
- ▶ The climate specifications in the technical data must be kept to at the mounting location.
- ▶ Stilling wells are unsuitable as a mounting location.
- ▶ The OTT RLS cannot be used to measure wave height.

---

#### WARNING



#### Danger of explosion due to spark formation and electrostatic discharge

The use of the OTT RLS in explosive atmospheres can lead to the danger of ignition of this atmosphere. An explosion resulting from this involves the risk of very severe material and personal damage.

- ▶ **Never** operate the OTT RLS in explosive areas (e.g. in sewers). The OTT RLS is not equipped with EX-protection (EXplosion protection)!
-

## 5.2 Notes on power supply

The OTT RLS requires a power supply of 9.6 ... 28 V direct current of type 12/24 V DC (e. g. a battery or mains connection with galvanically isolated low safety voltage).

The OTT RLS is immediately ready for operation after connecting the power supply.

### Warning:

- ▶ Secure the power supply cable (terminal 1 of the screw terminal strip) with a fuse (2.5 ampere, reaction time: fast)!
- ▶ When using solar panels, we recommend the use of an overvoltage protection device.

## 5.3 Suitable cable types when using the RS-485 interface

The maximum length of the connecting cable is 1,000 m · 3,300 ft. Recommended cable type: Twisted-pair cable; unshielded (alternatively: shielded). The wires intended for the power supply can be twisted pair, but do not have to be.

Types of OTT cable which can be used (see accessories)

- ▶ up to 500 m · 1,650 ft length of connecting cable: 2 x 2 x 0,5 mm<sup>2</sup>; approx. AWG 22 (flexible wires; 7 x AWG 30)
- ▶ 500 to 1000 m · 1,650 to 3,300 ft length of connecting cable: 2 x 2 x 0,75 mm<sup>2</sup>; AWG 20 (flexible wires; 7 x AWG 28)

## 5.4 Mounting the OTT RLS

**Warning:** Ensure no moisture enters the connection area when the screw cover is open! If the connection area gets moist there is increased danger of corrosion of the electric contacts.

### Assembling the swivel mount (see also Annex C)

Mounting surface: concrete or masonry

- Make four holes (Ø 8 mm · 5/16" / 43 mm · 1.7 ft deep) using a hammer drill (use wall bracket as a template).
- Insert the four plastic plugs supplied into the holes.
- Attach the wall bracket using the four wood screws supplied.
- Insert housing bracket (without sensor) into wall bracket and lightly tighten the hex bolts A (see fig. 5).

Mounting surface: auxiliary construction, e. g. metal stand with mounting plate

- Drill four holes (Ø 7 mm · 9/32") in the mounting plate (use wall bracket as a template).
- Attach the wall bracket e. g. using four hex bolts (M6) and nuts.
- Insert housing bracket (without sensor) into wall bracket and lightly tighten the hex bolts A (see fig. 5).

### Preparing the cable gland

- With a cable diameter of 7.0 ... 11.0 mm, remove inlet: Insert screwdriver vertically into the seam and lever out the inlet. See Figure 4.
- Insert the connecting cable.

### Mounting the radar sensor

- Remove screw cover.
- Insert connecting cable from OTT RLS to datalogger through cable gland.
- Remove insulation from connecting cable.
- With flexible wires: put end caps on the wires.
- Connect the connecting cable to the terminal block. Take note of Chapters 5.5 and 5.6 and Appendices A and B. If required, the terminal strip can be pulled out for connecting.
- Retighten connecting cable as necessary.
- Tighten the tightening nut of the cable gland (torque for tightening nut: 6 Nm).
- Screw on the screw cover and tighten firmly by hand.
- Insert sensor into housing bracket and lightly tighten the hex bolts B (see fig. 5).
- Align the housing parallel (longitudinal and lateral axis) with the water surface using a bubble level.
- Tighten the hex bolts B (housing shell) carefully (see fig. 5).
- Tighten the hex bolts A (wall/housing brackets) carefully (see fig. 5).
- Check alignment of the OTT RLS once more.

Fig. 4: OTT RLS – connection area.  
Clamping range of the cable gland:  
**with** inlet → 4.0 to 7.0 mm  
**without** inlet → 7.0 to 11.0 mm

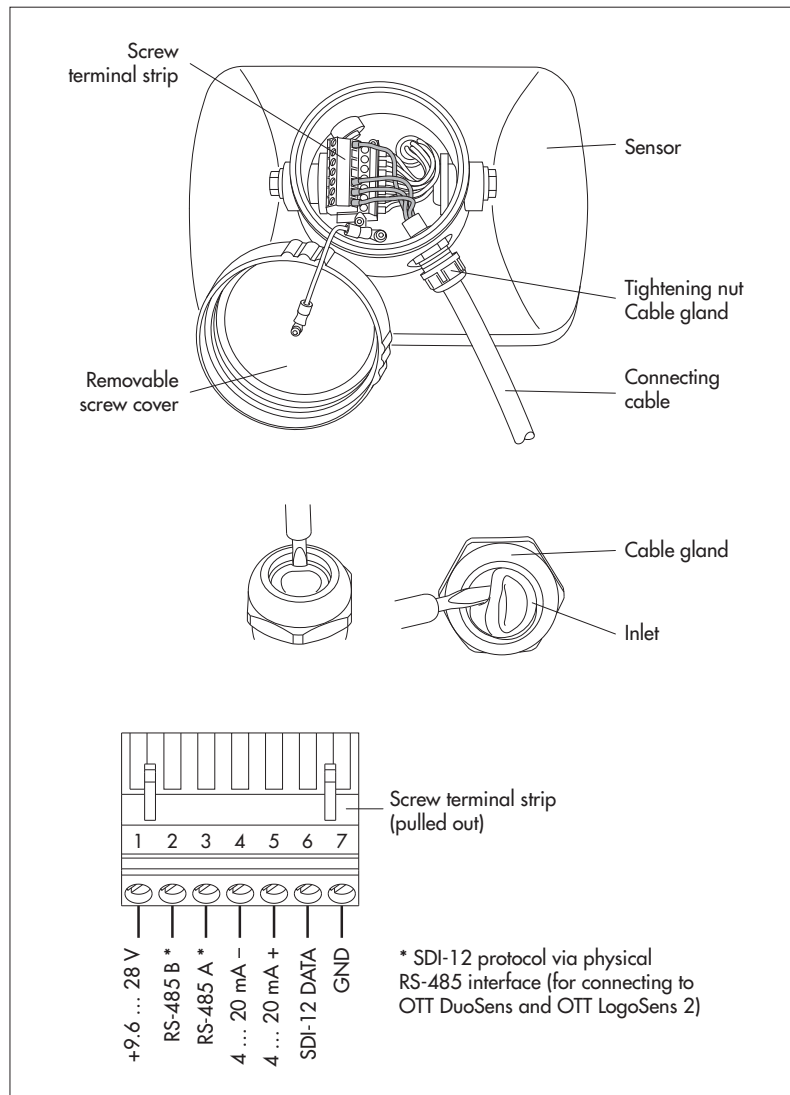

**Warning:** The alignment of the sensor parallel to the water surface must be carried out as accurately as possible!

- Deviation from the parallel alignment leads to a linearity error.
- Incorrect alignment of  $> 4^\circ$  can lead to a function failure of the OTT RLS (depending on the other operating parameters such as distance between lower sensor edge and water surface).

Fig. 5: OTT RLS – rotation range of swivel mount.

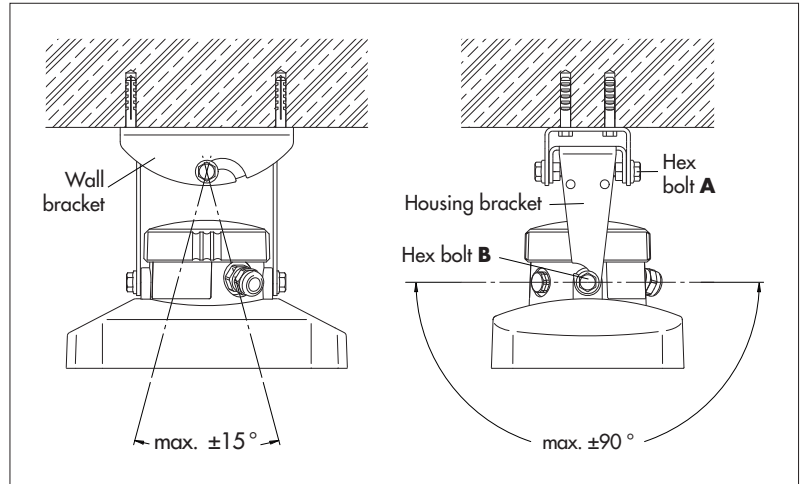

### 5.5 Connecting the OTT RLS to any datalogger using an SDI-12 interface

- Connect the OTT RLS to an SDI-12 input of the datalogger. Follow the datalogger handbook as you do this. Refer to Figure 6 for the connection assignments of the OTT RLS. The maximum length of the connecting cable is 100 m · 330 ft. Recommended wire cross-section:  $0.5 \text{ mm}^2$  · AWG 21. With separate voltage supply and point-to-point connection (no SDI-12 bus operation) a cable length of up to 300 m · 985 ft is possible.

Fig. 6: Connecting the OTT RLS to any datalogger using an SDI-12 interface. (Standard SDI-12 wiring via three-wire connecting cable).

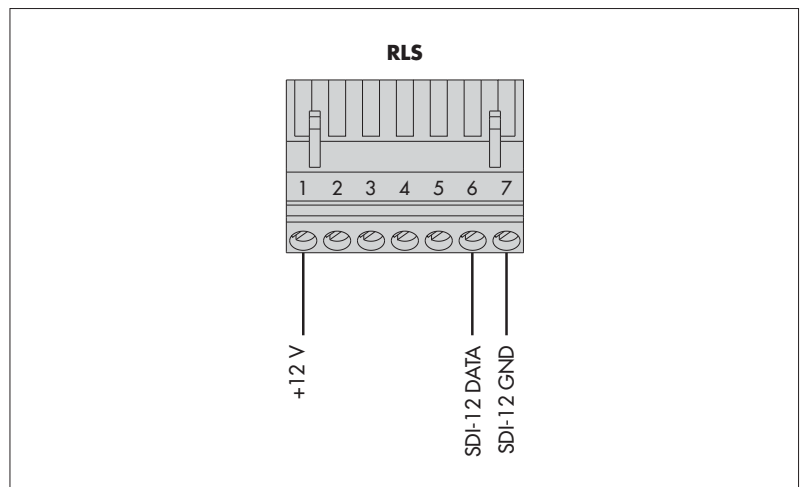

You will find the SDI-12 commands for the OTT RLS in Chapter 6, *SDI-12 commands and responses*.

## 5.6 Connecting the OTT RLS to any datalogger using a 4 ... 20 mA interface

- Connect the OTT RLS to a 4 ... 20 mA input of the datalogger. Follow the datalogger handbook when doing this. Refer to Figure 7 for the connection assignments of the OTT RLS. The maximum connecting cable length/recommended wire cross-section: depending on the amount of voltage supply and the size of the burden (load resistor). Please note that the ohmic resistance of the connecting cable together with the eventually existing burden do not exceed the max. allowed load resistance (see Chapter 5.7)!

**Caution:** the 4 ... 20 mA interface of the OTT RLS is passive. If needed the supply for the current loop must be injected by wire-linking the supply voltage.

**Tip:** To connect the OTT RLS using the 4 ... 20 mA interface, a 4-wire cable is required. If the OTT RLS is also to be configurable via SDI-12 commands, → use 5-wire (cable length up to 100 m) or 6-wire cable (cable length up to 1000 m).

Fig. 7: Examples for connecting the OTT RLS to any datalogger via the 4 ... 20 mA interface.

Left: supplying the loop current from the datalogger.  
Right: supplying the loop current to the OTT RLS supply voltage using wire bridges.

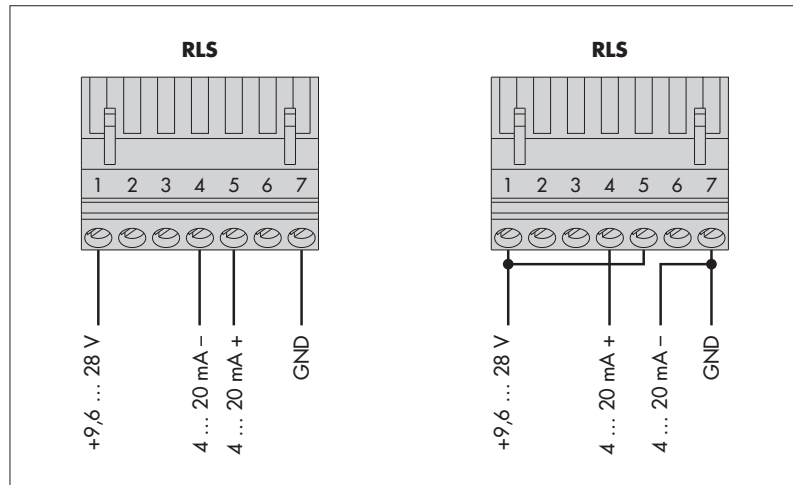

## 5.7 Determining the maximum load resistance at the 4 ... 20 mA interface

The load resistance (burden + ohmic resistance of the connection cable) connected to the OTT RLS must not exceed a specific maximum value. This value depends on the level of the supply voltage of the OTT RLS. If the load resistance is greater, the output current can no longer be evaluated. Smaller load resistances are allowed.

- Read off the maximum load resistance for your power supply from the following diagram.

**Example:** Power supply 18 volt → max. load resistance 450 ohm.

The OTT RLS delivers an output current corresponding to the measured value for a load resistance of up to 450 ohm.

- Dimension the connected electrical circuit accordingly. Check the input resistance of the connected peripheral device for this purpose.

Figure 8: Diagram to determine the maximum load resistance as a function of the power supply.

Minimum power supply: 9.6 V  
 Maximum power supply: 28 V

Resistor tolerance: 0.1 %/15 ppm  
 (burden = load resistor).

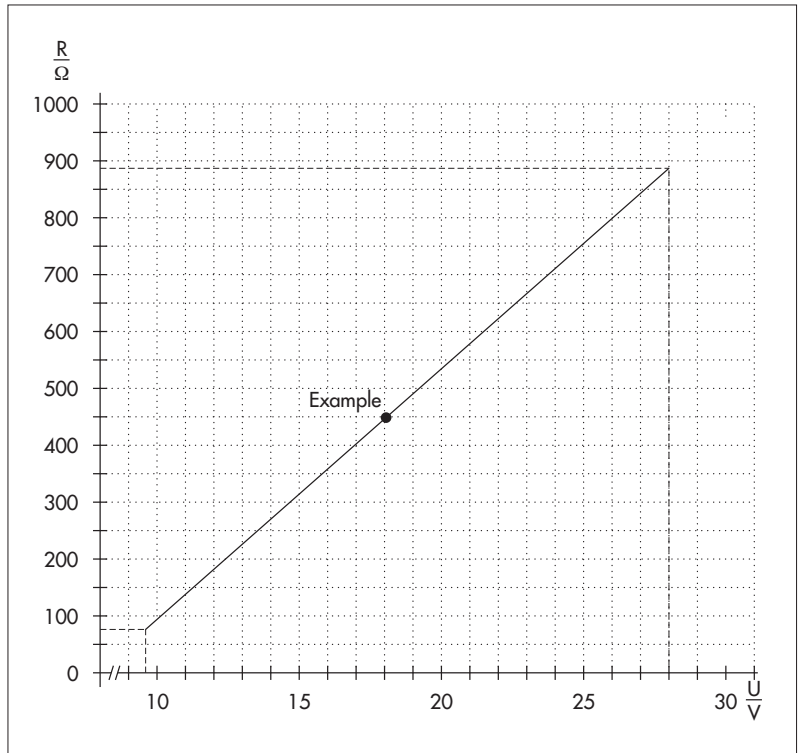

### 5.8 Notes on using the 4 ... 20 mA interface

- ▶ Switching behaviour of the 4 ... 20 mA interface  
 After switching on the supply voltage, it takes approx. 20 seconds until the loop current takes on a value proportional to the water level. (In the first 20 seconds, the loop current is between 3 and 4 mA.) Afterwards, the radar sensor updates the loop current every 20 seconds.
- ▶ **Caution:** The 4 ... 20 mA interface cannot be used parallel to the SDI-12 or RS-485 interfaces. (Exception: temporary configuration of the OTT RLS with SDI-12 commands.)

### 5.9 Note on using the RS-485 interface

The RS-485 interface can only be used with an OTT datalogger. In this case, the transmission protocol via the physical RS-485 interface is the SDI-12 protocol. Connect OTT RLS via the RS-485 interface to the OTT LogoSens/DuoSens → see Appendix A, version B.

## 6 SDI-12 commands and responses

### 6.1 Standard commands

All SDI-12 standard commands (SDI-12 version 1.1) are implemented in the OTT RLS: The following SDI-12 standard commands are relevant for the operation of the OTT RLS:

Command	Response	Description
<b>a!</b>	<b>a&lt;CR&gt;&lt;LF&gt;</b>	Confirmation active a – sensor address; factory setting = 0
<b>aI!</b>	<b>allccccccmmmmmm... ...vvvxxxxxx&lt;CR&gt;&lt;LF&gt;</b>	Send identification a – sensor address 11 – SDI-12 protocol version ccccccc – manufacturer's identification (company name) mmmmmm – sensor identification vvv – sensor version (here firmware version) xxxxxx – additional identification (here serial number) OTT RLS response = 011OTT HACH RLS110xxxxxx
<b>aAb!</b>	<b>b&lt;CR&gt;&lt;LF&gt;</b>	Change sensor address a – old sensor address b – new sensor address
<b>?!</b>	<b>a&lt;CR&gt;&lt;LF&gt;</b>	Query sensor address a – sensor address
<b>aM!</b> <sup>1)</sup>	<b>atttn&lt;CR&gt;&lt;LF&gt;</b> and after a max. of 25 seconds <b>a&lt;CR&gt;&lt;LF&gt;</b>	Start measurement a – sensor address ttt – time in seconds until the sensor has determined the measurement result OTT RLS response = 025 seconds n – number of measured values OTT RLS response = 2 <b>a&lt;CR&gt;&lt;LF&gt;</b> – service request
<b>aD0!</b>	<b>a&lt;value1&gt;&lt;value2&gt;&lt;CR&gt;&lt;LF&gt;</b>	Send data (after <b>aM!</b> ) a – sensor address <value1> – level/distance value: pbbbb.eee [m] <sup>2)</sup> pbbbb [cm] <sup>2)</sup> pbbbb.ee [ft] <sup>2)</sup> p – sign (+,-) b – digit (before the decimal point); output without leading zeroes! e – digit after the decimal point; output in the case of invalid measurement value: +99999999 (can be changed with advanced command <b>aOSI!</b> ) <value2> – status of the last measurement; for details, see response to command <b>aM!</b>
<b>aMC!</b> <sup>1)</sup>	<b>atttn&lt;CR&gt;&lt;LF&gt;</b> and after a max. of 25 seconds <b>a&lt;CR&gt;&lt;LF&gt;</b>	Start measurement and request CRC (Cyclic Redundancy Check). For details, see command <b>aM!</b> . The response to the following <b>aD0!</b> command is extended by a CRC value: <b>a&lt;value1&gt;&lt;value2&gt;&lt;CRC&gt;&lt;CR&gt;&lt;LF&gt;</b>
<b>aM1!</b> <sup>1)</sup>	<b>atttn&lt;CR&gt;&lt;LF&gt;</b> and immediately afterwards <b>a&lt;CR&gt;&lt;LF&gt;</b>	Query status of the last measurement a – sensor address ttt – time in seconds until the sensor makes the status available; OTT RLS response = 000 n – number of measured values OTT RLS response = 2 <b>a&lt;CR&gt;&lt;LF&gt;</b> – service request

<sup>1)</sup> do not use this command if OTT RLS is connected to a datalogger via the 4 ... 20 mA interface! OTT RLS would consequently interrupt the continuous measuring operation which is needed for the 4 ... 20 mA interface.

<sup>2)</sup> Dependent on the units set (advanced command **aOSU<value>!**)

Command	Response	Description
aD0!	a<value1><value2><CR><LF>	Send data (after aM1!) a – sensor address <value1> – status of the last measurement +0 = measured value O.K. +2 = no target recognised +4 = internal error → device fault. See Chapter 8, <i>Repair</i> +8 = variance of individual measurements too large +16 = SDI-12 interface interruption (breach of the SDI-12 interface protocol, e.g. communication with the SDI-12 interface between commands aM! and aD0!) +32 = internal error (temperature calibration values missing) → device fault. See Chapter 8, <i>Repair</i> <value2> – signal-to-noise ratio in dB. Value ≥ 15 dB = good signal quality (well-chosen mounting location and parallel alignment)
aMC1!	attn<CR><LF> and immediately afterwards a<CR><LF>	Query the status of the last measurement and request CRC (Cyclic Redundancy Check). For details, see command aM!. The response to the following aD0! command is extended by a CRC value: a<value1><value2><CRC><CR><LF>

More information on the SDI-12 standard commands can be found in the document *SDI-12; A Serial-Digital Interface Standard for Microprocessor-Based Sensors; Version 1.1* (see Internet page [www.sdi-12.org](http://www.sdi-12.org)).

## 6.2 Advanced SDI-12 commands

All advanced SDI-12 commands begin with an "o" for OTT. With these commands, it is possible to configure the OTT RLS using the transparent mode of a datalogger or with the OTT USB/SDI-12 interface (accessory).

Command	Response	Description
▶ Query firmware version		
a00V!	accccc<CR><LF>	Query the firmware version of the OTT RLS. a – sensor address cccccc – firmware version. Example: V1.10.0
▶ 4 ... 20 mA interface – set/read units for measurements		
aOPF<value>!	a<value><CR><LF>	Set units for commands aOPA<value>! and aOPB<value>!. Read unit for commands aOPA<value>! and aOPB<value>!. a – sensor address <value> – +0 = m +1 = cm +2 = ft
aOPF	a<value><CR><LF>	
▶ SDI-12-/RS-485 interface – set/read units for measurements		
aOSU<value>!	a<value><CR><LF>	Set units for commands aM!; aMC!; aOAB<value>! and aOAC<value>!. Read unit for commands aM!; aMC!; aOAB<value>! and aOAC<value>!. a – sensor address <value> – +0 = m +1 = cm +2 = ft
aOSU!	a<value><CR><LF>	

### Caution

Changing the unit deletes any set reference or offset value!

Command	Response	Description
▶ Set/read measuring mode level or distance measurement		
aOAA<value>! aOAA!	a<value><CR><LF> a<value><CR><LF>	Set measuring mode Read out measuring mode <b>a</b> – sensor address <value> – +0 = measuring mode <i>Level measurement</i> activated (water level related to a level zero) +1 = measuring mode <i>Distance measurement</i> activated (distance of OTT RLS ↔ water surface) Factory setting = +1
<b>Caution</b> If entries have been made before changing the measuring mode for the parameters aOAB<value>!, aOAC<value>!, aOPA<value>! or aOPB<value>!, these must be input again! There is no automatic conversion of the parameters entered.		
▶ Set/read error indicator		
aOSI<value>! aOSI!	a<value><CR><LF> a<value><CR><LF>	Set error indicator Read error indicator <b>a</b> – sensor address <value> – error indicator that the OTT RLS outputs an invalid measurement <b>p</b> – sign (+,-) <b>b</b> – digit Value range: -99999999 ... +99999999 Factory setting = +99999999
▶ Set/read 4 ... 20 mA interface – operating status (activated/deactivated)		
aOPC<value> aOPC!	a<value><CR><LF> a<value><CR><LF>	Set operating status Read operating status <b>a</b> – sensor address <value> – <b>pb</b> ; factory setting = +1 <b>p</b> – sign (+) <b>b</b> – digit +0 = interface deactivated +1 = interface activated
Use: the command aOPC+1! is helpful, if e.g. an aM! command unintended has interrupted the continuous operation which is needed for the 4 ... 20 mA interface.		
▶ 4 ... 20 mA interface – setting/reading the lower limit		
aOPA<value>! aOPA!	a<value><CR><LF> a<value><CR><LF>	Set lower limit Read lower limit <b>a</b> – sensor address <value> – <b>pbbbb.eee</b> [m] * – <b>pbbbb</b> [cm] * – <b>pbbbb.ee</b> [ft] * <b>p</b> – sign (+,-) <b>b</b> – digit (before the decimal point) <b>e</b> – digit after the decimal point Input/output without leading zeroes! Value range: -9999.999 ... +9999.999 * Factory setting = +0.000 * Dependent on the units set (aOPF<value>!)
<b>Note</b> If the units are subsequently changed (aOPF<value>!), the OTT RLS resets the set limit to the factory setting.		

Command	Response	Description
▶ 4 ... 20 mA interface – setting/reading the upper limit		
aOPB<value>!	a<value><CR><LF>	Set upper limit
aOPB!	a<value><CR><LF>	Read upper limit
		<b>a</b> – sensor address
		<value> – pbbbb.eee [m] *
		– pbbbb [cm] *
		– pbbbb.ee [ft] *
		<b>p</b> – sign (+,-)
		<b>b</b> – digit (before the decimal point)
		<b>e</b> – digit after the decimal point
		Input/output without leading zeroes!
		Value range: -9999.999 ... +9999.999 *
		Factory setting = +0.000
		* Dependent on the units set (aOPF<value>!)
		<b>Note</b>
		If the units are subsequently changed (aOPF<value>!), the OTT RLS resets the set limit to the factory setting.

With the commands *setting/reading the lower/upper limit* you can scale the available measuring range of an OTT RLS to a smaller range. Where you do not require the whole measuring range, this has the advantage that a higher resolution for the 4 ... 20 mA interface can be achieved. Example: 16 mA measurement span stands for 5 m · 16 ft of water level change available (e.g. lower limit = +10,000 m · +33,00 ft; upper limit = +15,000 m · +49.00 ft; see Fig. 9).

Fig. 9: Scale the measured value output of the 4 ... 20 mA interface down to a smaller range.

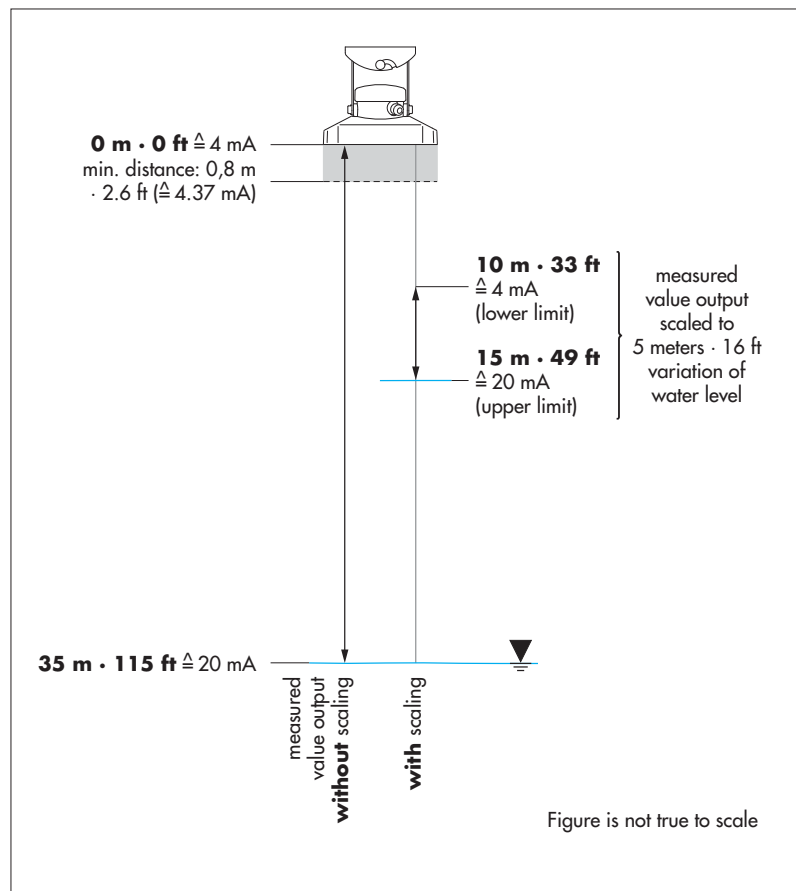

Command	Response	Description
▶ SDI-12-/RS-485 interface – set/read offset for level/distance measurement		
aOAB<value>!	a0251<CR><LF> and after a max. of 25 seconds a<CR><LF>	Set offset value
aOAB!	a<value><CR><LF>	Read offset value <b>a</b> – sensor address <b>&lt;value&gt;</b> – pbbbb.eee [m] * – pbbbb [cm] * – pbbbb.ee [ft] * <b>p</b> – sign (+,-) <b>b</b> – digit (before the decimal point) <b>e</b> – digit after the decimal point <b>a&lt;CR&gt;&lt;LF&gt;</b> – service request Input/output without leading zeroes! Value range: -9999.999 ... +9999.999 * Factory setting = +0.000  With this command, you can add a linear offset (positive/negative) to a level/distance measurement. After setting the offset value, the OTT RLS automatically starts a measurement. After receiving the service request, check the measured value with command aD0!. If input is unsuccessful, the radar sensor replies with a new service request.
<b>Caution</b> This command overwrites any set reference value.		
<b>Example</b> Measurement = +10,040 m Offset = -0,200 m Output = +9,840 m		
<b>Note</b> If the units are subsequently changed (aOSU<value>!), the OTT RLS resets the set offset value to the factory setting.		
▶ SDI-12-/RS-485 interface – set/read reference value for the offset for level/distance measurement		
aOAC<value>!	a0251<CR><LF> and after a max. of 25 seconds a<CR><LF>	Set reference value
aOAC!	a<value><CR><LF>	Read reference value <b>a</b> – sensor address <b>&lt;value&gt;</b> – pbbbb.eee [m] * – pbbbb [cm] * – pbbbb.ee [ft] * <b>p</b> – sign (+,-) <b>b</b> – digit (before the decimal point) <b>e</b> – digit after the decimal point <b>a&lt;CR&gt;&lt;LF&gt;</b> – service request Input/output without leading zeroes! Value range: -9999.999 ... +9999.999 * Factory setting = +0.000  With this command, you can establish a reference to a level zero, for example, by entering a reference value for level/distance measurement. * Dependent on the units set (aOSU<value>!)

**Command****Response****Description**

After setting the reference value, the OTT RLS automatically starts a measurement. After receiving the service request, check the measured value with command `aD0!`. After an unsuccessful entry, the radar sensor replies with a new service request.

**Caution**

This command overwrites any set offset value.

**Example**

Measurement = +2,100 m

Reference value = +1,500 m

Output = +1,500 m

(offset calculated by the OTT RLS and applied to all other measured values = +0.600 m)

**Note**

If the units are subsequently changed (`aOSU<value>!`), the OTT RLS resets the set reference value to the factory setting.

## 7 Carrying out maintenance work

The OTT RLS radar sensor is almost maintenance free. No setting or calibration work is necessary. There are likewise no parts that need replacing regularly.

Carry out the following maintenance work at regular frequencies based on the local circumstances:

- Check the OTT RLS for dirt (e.g. thick, dewy spider's webs or insect nests can lead to impairment of the measured results). In this case, carefully clean the sensor (if necessary use commercial, gentle and non-erasing cleaners and a soft sponge). At the same time, ensure that the setting of the swivel mount does not change.
- Check for obstructions in the measurement beam (for example, for flotsam or branches of trees and bushes growing into this area). In this case, remove all obstructions.
- Check the plausibility of the measured values by comparing with a second sensor or with a staff gauge.

**Warning:** Never open the housing of the OTT RLS (exception: connection area)! There are no adjustment or operating elements inside the housing.

## 8 Repair

- With a device defect, use Chapter 9, *Troubleshooting* to see if you can resolve the problem yourself.
- In case of device defects, please contact the repair center of OTT:

OTT MESSTECHNIK GmbH & Co. KG  
Repaircenter  
Ludwigstrasse 16  
87437 Kempten · Germany  
Telephone +49 831 5617-433  
Fax +49 831 5617-439  
repair@ott.com

**Warning:** Only have a defective OTT RLS checked and repaired by the OTT repair center. Never make any repairs yourself under any circumstances. Any repairs or attempted repairs carried out by the customer will result in the loss of any guarantee rights.

## 9 Troubleshooting

### Sensor does not respond to the SDI-12 interface

- ▶ Fuse in the power supply input side defective?  
→ Replace fuse.
- ▶ Sensor correctly connected to a datalogger with SDI-12 input (master)?  
→ Correct connection assignment.
- ▶ Polarity of the power supply reversed?  
→ Correct connection assignment.
- ▶ Power supply < 9.6 V or > 28 V?  
→ Correct level of voltage supplied (check the length and cross-section of the connection cable).
- ▶ Is the power supply direct current?  
→ Only operate sensor with direct current.

### 4 ... 20 mA signal not present

- ▶ Sensor correctly connected to a datalogger or peripheral device to 4 ... 20 mA input (check polarity)?  
→ Correct connection assignment.
- ▶ 4 ... 20 mA current loop correctly supplied through datalogger or OTT RLS (internal/external supply)?  
→ Correct connection assignment.

### Measured value varies or is not present

- ▶ Sensor (front plate) dirty?  
→ Carefully clean the sensor; see Chapter 7, *Carrying out maintenance work*
- ▶ Obstruction in the measurement beam?  
→ Remove obstructions.
- ▶ Sensor aligned at right angles to the water surface?  
→ Correct sensor alignment.
- ▶ Mounting location of the sensor steady (e.g. bridge movement)?  
→ Optimize mounting location.
- ▶ Large metal surfaces near the sensor beam (e.g. piling)?  
→ Optimize mounting location.

### Status messages/output of interfaces

SDI-12 <sup>1)</sup>	4 ... 20 mA	Status message/output
+0	measured value	measured value OK
+2	3.0 mA	no target recognized
+4	3.1 mA	internal error → device defect; see Chapter 8, <i>Repair</i>
+8	3.2 mA	variance of individual measurements too large
+16	3.3 mA	SDI-12 interface break (infringement of SDI-12 interface protocol, e.g. communication via SDI-12 interface between the commands <b>aM!</b> and <b>aD0!</b> )
-	3.4 mA	value below or above measuring range
+32	3.5 mA	internal error → device defect; see Chapter 8, <i>Repair</i>

<sup>1)</sup> response to commands **aM!**, **aM1!** and **aD0!**

## 10 Note about the disposal of old units



### Within the member countries of the European Union

In accordance with the European Union guideline 2002/96/EC, OTT takes back old devices within the member countries of the European Union and disposes of them in an appropriate way. The devices concerned by this are marked with the symbol shown aside.

- For further information on the return procedure, please contact your local sales contact. You will find the addresses of all sales partners in the internet on [www.ott.com](http://www.ott.com). Please take into consideration also the national implementation of the EU guideline 2002/96/EC of your country.

### For all other countries

- Dispose of the OTT RLS properly after taking out of service.
- Observe the regulations valid in your country for the disposal of electronic devices.
- Never put the OTT RLS into the normal household waste.

### Used materials

see Chapter 11, *Technical Data*

## 11 Technical Data

Measuring range	0.8 ... 35 m	80 ... 3500 cm	2.6 ... 115 ft
Resolution SDI-12 interface	0.001 m	1 cm	0.01 ft
Accuracy (SDI-12) <sup>1)</sup>			
0.8 ... 1.5 m	±10 mm · ±0.03 ft		
1.5 ... 30 m	±3 mm · ±0.01 ft		
30 ... 35 m	±10 mm · ±0.03 ft		
Average temperature coefficient (range: -20 ... +60 °C · -4 ... +140 °F)	0.01 % of full scale/10 K		
Accuracy (4 ... 20 mA) <sup>1)</sup>	±0.1% of full scale		
Average temperature coefficient (at +20 °C · +68 °F)	10 ppm of full scale/K		
Measuring time	20 seconds		
Power supply	9.6 ... 28 V DC, typ. 12/24 V DC		
Power consumption <sup>2)</sup>			
Measurement operation	< 140 mW (< 12 mA at 12 V)		
Rest mode	< 1 mW (< 0.05 mA at 12 V)		
Interfaces	4 ... 20 mA (measurement update every 20 seconds); SDI-12; RS-485, two-wire (SDI-12 protocol)		
Beam angle of antenna	12 ° (±6 °)		
Transmission frequency	24 GHz (puls radar)		
Transmission power	< 5 mW		
Materials			
Housing	ASA (UV-stabilized ABS)		
Radom (front plate)	TFM PTFE		
Mounting	1.4301 (V2A)		
Weight (including mounting)	approx. 2.1 kg · 4.63 lb		
Cable gland sealing range			
with inlet (min. Ø ... max. Ø)	4.0 ... 7.0 mm · 0.16 ... 0.28"		
without inlet (min. Ø ... max. Ø)	7.0 ... 11.0 mm · 0.28 ... 0.43"		
Connection capacity of screw terminal strip			
Solid conductor	0.25 ... 2.5 mm <sup>2</sup> · AWG 24 to 12		
Wire with end cap and plastic collar	0.25 ... 1.5 mm <sup>2</sup> · AWG 24 to 16		
Terminal assignment screw terminal strip			
Terminal 1	power supply		
Terminal 2	RS-485 B		
Terminal 3	RS-485 A		
Terminal 4	4 ... 20 mA -		
Terminal 5	4 ... 20 mA +		
Terminal 6	SDI-12 DATA		
Terminal 7	GND		
Rotation range of swivel mount			
Lateral axis	±90 °		
Longitudinal axis	±15 °		
Type of protection at horizontal installation	IP 67 (submersion depth max. 1 m · 3.3 ft; Submersion duration max. 48 h)		
Dimensions L x W x H	222 mm x 152 mm x 190 mm · 8.74" x 5.98" x 7.48"		
Temperature range			
Operation	-40 ... +60 °C · -40 ... +140 °F		
Storage	-40 ... +85 °C · -40 ... +185 °F		
Relative humidity	0 ... 100 % <sup>3)</sup>		

<sup>1)</sup> at +20 °C · +68 °F ambient temperature: 1013 mbar · 29.9 inHg air pressure; 45 % to 65 % relative humidity; ideal reflector; without interfering reflector in the sensor beam

<sup>2)</sup> Power consumption of OTT RLS with SDI-12, RS-485 or externally supplied 4 ... 20 mA interface

<sup>3)</sup> Condensation on the front plate of the antenna (Radom) can disturb measuring accuracy

Performance classification in accordance with DIN EN ISO 4373

Measurement reliability

Temperature range

Relative humidity

Performance class 1

Temperature class 1

Class 1

EMC limits and radio approvals

EMV for Short Range Device

Safety of equipment of low voltage device

Approval for Short Range Device; Europe

Approval for Short Range Device; USA

Approval for Short Range Device; Canada

ETSI EN 301 489-3

EN 60950-1

ETSI EN 300 440

FCC 47 CFR Part 15

RSS 210 Issue 7



## Annex A – Connecting the OTT RLS via SDI-12 or RS-485 interface to LogoSens 2 or DuoSens

There are two ways to connect the OTT RLS:

- ▶ Method A: using the SDI-12 interface (protocol and physical interface: SDI-12).
- ▶ Method B: using the RS-485 interface (SDI-12 protocol via physical RS-485 interface).

Recommendation: method B (longer range, more resistant to faults)

**Method A:** Connecting the OTT RLS via the SDI-12 interface (protocol and physical interface: SDI-12). The maximum length of the connecting cable is 100 m · 330 ft. Recommended wire cross-section: 0.5 mm<sup>2</sup> · AWG 21:

- Connect the OTT RLS to the LogoSens 2 Station Manager or to the DuoSens Compact Datalogger as shown in Figure 10. Take note of the operating instructions for the LogoSens 2/DuoSens.

Fig. 10: Connecting the OTT RLS to LogoSens 2 or DuoSens using an SDI-12 interface.

The letters above the screw terminal strip identify the possible connections on the LogoSens 2/DuoSens.

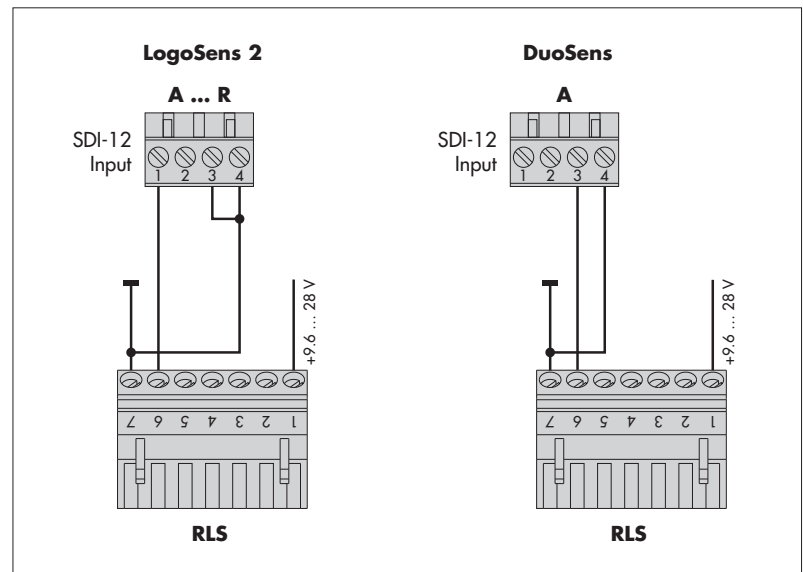

**Method B:** Connect OTT RLS using the physical RS-485 interface (SDI-12 protocol via physical RS-485 interface). Refer to Chapter 5.3 for the maximum connecting cable length and the recommended wire cross-section:

- Connect the OTT RLS to the LogoSens 2 Station Manager or to the DuoSens Compact Datalogger as shown in Figure 11. Take note of the operating instructions for the LogoSens 2/DuoSens.

Fig. 11: Connecting the OTT RLS to LogoSens 2 or DuoSens using an RS-485 interface (SDI-12 protocol).

The letters above the screw terminal strip identify the possible connections on the LogoSens 2/DuoSens.

When connecting the OTT RLS to the LogoSens 2, use a 120 Ohm terminator (order number: 96.300.205.9.5).

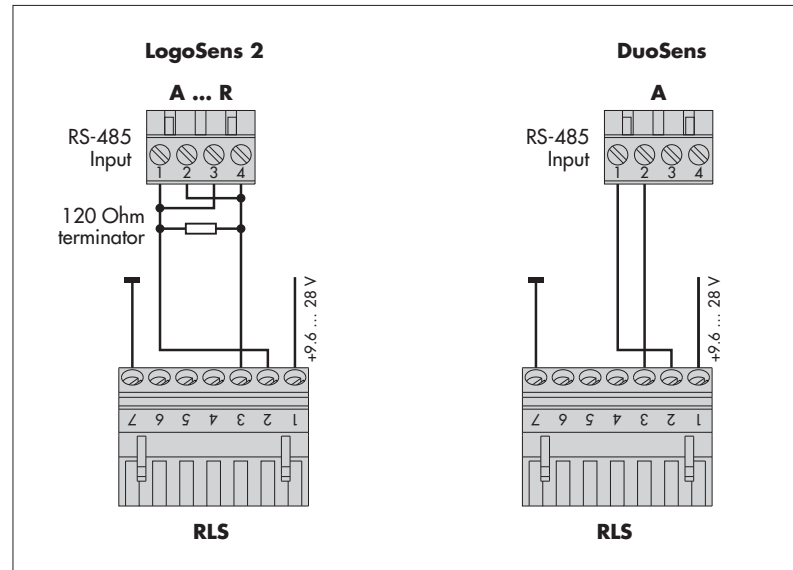

## Configuring the LogoSens 2/DuoSens for the OTT RLS with SDI-12 interface

- Create a LogoSens 2/DuoSens channel with *SDI-12 Master* or *OTT SDI RS485* function block (*serial sensors* tab).
- Apply the following settings:

Fig. 12: Adjusting the operating parameters of the LogoSens 2/DuoSens *SDI-12 Master* function block. The function block *OTT SDI RS485* is set in the same way.

- ▶ Terminal block  
LogoSens 2: A ... R  
DuoSens *SDI-12 Master*: A 3-4 (specified)  
DuoSens *OTT SDI RS485*: A 1-2 (specified)  
terminal block used (screw terminal strip) of the LogoSens 2/DuoSens.
- ▶ Slave address  
SDI-12 bus address. Each address may only be allocated once to an SDI-12 bus feed! (Checking/setting: see operating instructions LogoSens 2/DuoSens, Chapter *SDI-12 transparent mode*; alternatively with OTT USB/SDI-12 interface)  
Factory setting of the OTT RLS: 0
- ▶ Value no.  
1  
Identifies which value from the OTT RLS is recorded in this channel. (The OTT RLS determines two values with the command **am!**: measurement and status information.)
- ▶ Measurement mode  
*M!* (SDI-12 measurement command for this channel)
- ▶ Value no./  
Virtual terminal ID  
Allocation of the status information to a virtual terminal.
- In the relevant *Channel* function blocks, adjust the required units and number of digits after the decimal place (m: 3; cm: 0; ft: 2; status information: 0).

### Note:

- ▶ To record the measurements and status information of an OTT RLS, two channels in the LogoSens 2/DuoSens are thus necessary. The first channel contains the function block *SDI-12 Master* or *OTT SDI RS485* as the input signal. The second channel contains a function block *Virtual Sensor (V02)* as the input signal. If the recording of status information is not required, no entry is necessary in the *Value no./Virtual terminal ID* field.
- ▶ The measuring mode *M1!* supplies extended status information. If required, this can also be recorded in an additional channel with function block *SDI-12 Master/OTT SDI RS485*.
- ▶ You will find further information on the used SDI-12 commands and responses in Chapter 6, *SDI-12 commands and responses*.

**Please note:** The OTT PLS makes the measurement results available a maximum of 25 seconds after the SDI-12 command **am!**!

## Annex B – Connecting the OTT RLS to LogoSens 2 or DuoSens using a 4 ... 20 mA interface

- Connect the OTT RLS to the LogoSens 2 Station Manager or to the DuoSens Compact Datalogger as shown in Figure 13 and 14. Take note of the operating instructions for the LogoSens 2/DuoSens. Maximum connecting cable length/recommended wire cross-section: depending on the amount of voltage supply and the size of the burden (load resistor). Please note that the ohmic resistance of the connecting cable together with the eventually existing burden do not exceed the max. allowed load resistance (see Chapter 5.7)!

Fig. 13: Connecting the OTT RLS to LogoSens 2 using a 4 ... 20 mA interface

Use the 100 Ohm OTT resistor (order number: 55.550.800.9.5).

The letters above the screw terminal strip identify the possible connections on the LogoSens 2.

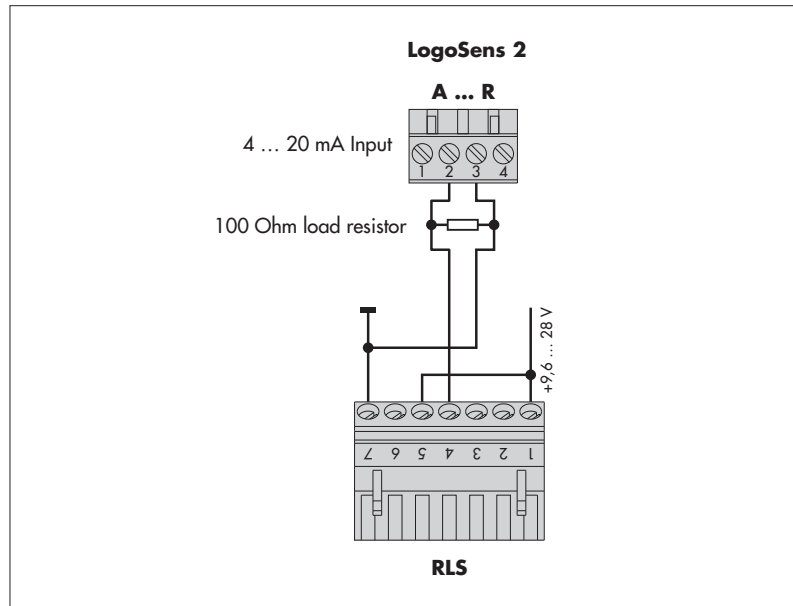
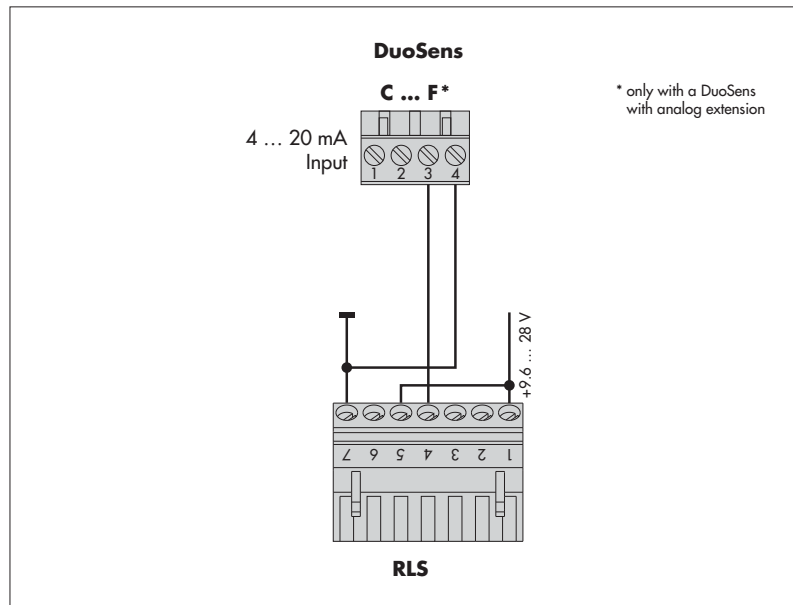

Fig. 14: Connecting the OTT RLS to DuoSens using a 4 ... 20 mA interface.

The letters above the screw terminal strip identify the possible connections on the DuoSens.



## Configuring the LogoSens 2/DuoSens for OTT RLS with 4 ... 20 mA interface

- Create a LogoSens 2/DuoSens channel with function block *I 4-20 mA* (LogoSens 2) or *U/I/Pt100/...* (DuoSens) (*Analog sensors* tab).
- Apply the following settings:

Fig. 15: Setting operating parameters of the LogoSens 2 *I 4-20 mA* function block.

The DuoSens function block *U/I/Pt100/...* is set in the same way.

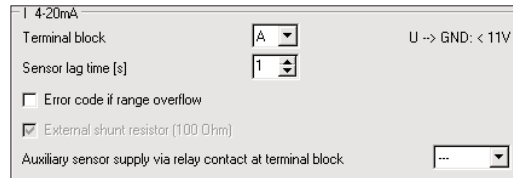

- ▶ Terminal block
  - LogoSens 2: A ... R
  - DuoSens: C ... F
  - terminal block used (screw terminal strip) of the LogoSens 2/DuoSens.
  - Set to *I 4-20 mA ext.*
- ▶ Measurement mode (only with DuoSens)
- ▶ Sensor lag time (s)
  - switches on the LogoSens 2/DuoSens input 1 second before the actual measurement process
- ▶  Error code if range overflow
  - if required: record error codes on range overflow
- ▶ Auxiliary sensor supply via relay contact at terminal block (only for LogoSens 2)
  - not required with an OTT RLS
- Insert a *2-point scaling* function block into this channel and adjust the relating distance values for the outputed current values (e. g. Point 1: 4 → 0; Point 2: 20 → 35 m · 115 ft). This function also enables the referencing to a level zero.
- In the *Channel* function block, set the unit and number of digits after the decimal place (m: 3; cm: 0; ft: 2)..





**Konformitätserklärung  
Declaration of Conformity  
Declaration de Conformité**

Wir/ We/ Nous  
Anschrift/ Address/ Adresse

OTT Messtechnik GmbH & Co. KG  
Ludwigstraße 16  
D-87437 Kempten

erklären, daß das Produkt/ declare, that the product/ déclarons, que le produit

Bezeichnung/ Name/ Nom **OTT RLS**

Artikel- Nr./ Article No./ No. d' Article **63.105.001.9.2**

mit den Anforderungen der Normen/ fulfills the requirements of the standard/ satisfait aux exigences des normes

EG (2004/108/EG):

Electromagnetic compatibility and Radio Spectrum Matters (ERM)  
ElectroMagnetic Compatibility (EMC)  
for Short Range Devices (9kHz to 40GHz)  
ETSI EN 301 489-3 V1.4.1 (2002-08)  
EN 61000-4-5 (4kV); IEC 61000-4-5 (4kV)

Electromagnetic compatibility and Radio Spectrum Matters (ERM)  
for Short Range Devices (1GHz to 40GHz)  
ETSI EN 300 440-2 V1.1.1 (2001-09)

Safety of Electrical Equipment and Industrial Low-Voltage Devices  
EN 60950-1:2001; IEC 60950-1:2001

Radio Standards Specification (RSS)  
RSS-210 Issue 7

Radio Frequency Devices  
FCC 47 CFR Part 15

und den hinterlegten Prüfberichten übereinstimmt und damit den Bestimmungen entspricht/  
and the taken test reports and therefore corresponds to the regulations of the Directive/  
et les rapports d'essais notifiés et, ainsi, correspondent aux réglement de la Directive.

Ort und Datum der Ausstellung/  
Place and Date of Issue/  
Lieu et date d' établissement

Kempten, den 2007-09-20

Name und Unterschrift des Befugten/  
Name and Signature of authorized person/  
Nom et signature de la personne autorisée

*i.v. Peter Fend*

Peter Fend  
( Director R&D )

OTT MESSTECHNIK GmbH & Co. KG  
Postfach 21 40 · 87411 Kempten  
Ludwigstraße 16 · 87437 Kempten  
Tel.: +49 (0) 831 / 56 17-0  
Fax: +49 (0) 831 / 56 17-209  
info@ott-hydrometry.de  
[www.ott-hydrometry.de](http://www.ott-hydrometry.de)

Geschäftsführer: Dr.-Ing. Anton Felder · Persönlich haftende Gesellschafterin: OTT MESSTECHNIK Verwaltungs GmbH  
Sitz der Ges.: Kempten · Registergericht Kempten HRB 7687 und HRA 3807 · USt.-ID.-Nr. DE 128 780 710 · Steuer-Nr. 127/171/51206

Deutsche Bank AG · BLZ 700 700 10 · Kto.Nr. 409 0304 00 · BIC: DEUTDE33 · IBAN: DE96 7007 0010 0409 0304 00  
Commerzbank AG München · BLZ 733 400 46 · Kto.Nr. 775 0649 00 · BIC: COBADE33 · IBAN: DE13 7334 0046 0775 0649 00  
Sparkasse Allgäu · BLZ 733 500 00 · Kto.Nr. 18 861 · BIC: BYLADEM1ALG · IBAN: DE24 7335 0000 0000 0188 61

**TCB**

**GRANT OF EQUIPMENT  
AUTHORIZATION**

**TCB**

**Certification  
Issued Under the Authority of the  
Federal Communications Commission  
By:**

**PHOENIX TESTLAB GmbH  
Koenigswinkel 10  
D-32825 Blomberg,  
Germany**

**Date of Grant: 08/29/2007  
Application Dated: 08/29/2007**

**Ott Messtechnik GmbH & Co. KG  
Ludwigstrasse 16  
PO Box 21 40  
Kempten D-87437,  
Germany**

**Attention: Mr. Kay Zircher , Manager**

**NOT TRANSFERABLE**

EQUIPMENT AUTHORIZATION is hereby issued to the named GRANTEE, and is VALID ONLY for the equipment identified hereon for use under the Commission's Rules and Regulations listed below.

**FCC IDENTIFIER: OA6OTTRLs**  
**Name of Grantee: Ott Messtechnik GmbH & Co. KG**  
**Equipment Class: Part 15 Low Power Communication Device  
Transmitter**  
**Notes: Radar Level Sensor**

<u>Grant Notes</u>	<u>FCC Rule Parts</u>	<u>Frequency Range (MHZ)</u>	<u>Output Watts</u>	<u>Frequency Tolerance</u>	<u>Emission Designator</u>
	15C	24150.0 - 24150.0			

This device must be professionally installed.

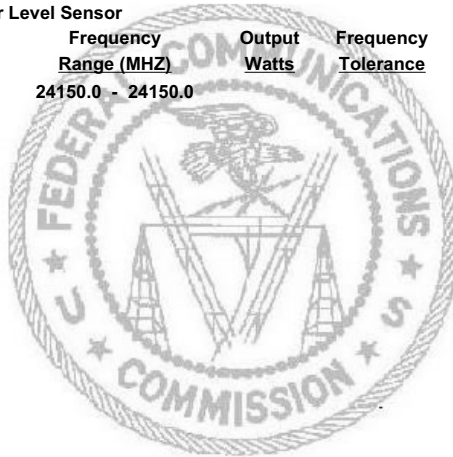



**TECHNICAL APPROVAL  
CERTIFICATE**

based on the Agreement on Mutual Recognition  
between the European Community and Canada

**CERTIFICAT D'APPROBATION  
TECHNIQUE**

en se basant l'accord de reconnaissance mutuelle  
entre la Communauté Européenne et le Canada

CERTIFICATION NUMBER  
NUMÉRO DE CERTIFICATION

7253A-OTTRLS

TYPE OF SERVICE  
TYPE DE SERVICE

New Single Certification

CERTIFICATE HOLDER  
TITULAIRE DU CERTIFICAT

OTT MESSTECHNIK GmbH & Co. KG  
Ludwigstrasse 16  
87411 Kempten  
Germany

TYPE OF EQUIPMENT  
GENRE DE MATÉRIEL

RADAR LEVEL SENSOR

TRADE NAME AND MODEL  
MARQUE ET MODELE

OTT / RLS

FREQUENCY RANGE  
BANDE DE FRÉQUENCES

24.15 GHz

EMISSION DESIGNATION (TRC-43)  
DÉSIGNATION D'ÉMISSION (CRT-43)

1G33P0N

CONDUCTED POWER RATING (WATT)  
PUISSANCE NOMINALE (WATT)

—

ANTENNA INFORMATION  
INFORMATION D'ANTENNE

Integral Radom-Antenna

ACCESSORIES  
ACCESSOIRES

—

CONTACT INFORMATION OF TESTING LABORATORY  
COORDONNÉES DU LABORATOIRE D'ESSAI

PHOENIX TESTLAB GMBH  
Koenigswinkel 10  
32825 Blomberg  
Germany

CERTIFIED TO SPECIFICATION / ISSUE  
CERTIFIÉ SELON LE CAHIER DES CHARGES / ÉDITION

RSS-210 Issue 7, RSS-GEN Issue 2  
RSS-102 Issue 2

Certification of equipment means only that the equipment has met the requirements of the above noted specification. License applications, where applicable to use certified equipment, are acted on accordingly by the issuing office and will depend on the existing radio environment, service and location of operation. This certificate is issued on condition that the holder complies and will continue to comply with the requirements of the radio standards specifications and procedures issued by the Department.

*La certification du matériel signifie seulement que le matériel a satisfait aux exigences de la spécification indiquée ci-dessus. Les demandes de licences nécessaires pour utiliser du matériel certifié sont traitées en conséquence par le bureau de délivrance et dépendront de l'environnement radio existant, du service et du lieu d'exploitation. Le présent certificat est délivré à la condition que le titulaire satisfasse et continue de satisfaire aux exigences de les cahiers des charges sur les normes radioélectriques et aux procédures du Ministère.*

Labelling of Certified Radio Equipment:

Certified radio equipment must be labelled with a unique certification/registration number, which consists of the Company Number (CN), assigned by the Bureau, followed by the Unique Product Number (UPN) assigned by the certificate holder **IC: 7253A-OTTRLS**

**A radio equipment that is issued a TAC or a Certificate but is not properly labelled is not considered certified.**

Étiquetage du matériel radio homologué:

Le matériel radio homologué doit porter une étiquette sur laquelle figure un seul et unique numéro d'homologation/enregistrement qui est formé du numéro de compagnie (NC), attribué par le Bureau, et du numéro de produit unique (NPU), attribué par le titulaire du certificat. **IC: 7253A-OTTRLS**  
**N'est pas considéré homologué tout matériel radio mal étiqueté et pour lequel un CAT ou un certificat a été délivré.**

PTL NO.: DE0003

Signed by / Signataire Dirk Brandhorst

Blomberg, 29 August 2007

Foreign Certification Body (FCB)

## Annex G

### RLS Sensor Wiring Terminal Connections to Datalogger using FIN4COND-L

```
'CR1000 12V (FIN4COND-L Red) - RLS 12V Power (1)
'CR1000 G (FIN4COND-L Black) - RLS Ground Reference (7)
'CR1000 C1 (FIN4COND-L White) - RLS SDI-12 Data (6)
'CR1000 G (FIN4COND-L Green) - RLS Ground Reference (7)

'Declare Public Variables
Public RLS(2)
Public Water_Level
Public Trigger_Measurement As Boolean 'Flag_1 can used to trigger an RLS measurement.
Public Distance_to_Ground
Public Radar_Status As String *30 'Output RLS status as a description (see manual).

'Declare Alias' for the RLS() Public Variables
Alias RLS(1) = Radar_Distance

'Declare Units for RLS Variables.
Units Radar_Distance = Meters 'default. Other units can be configured via SDI-12.
Units Distance_to_Ground = Centimeters
Units Water_Level = Centimeters

'Define Data Tables
DataTable (RLS_Data,1,-1)
  DataInterval (0,15,Min,10)
  Sample(1,Water_Level,IEEEE4)
  Sample (1,Radar_Distance,FP2)
  Sample (1,Radar_Status,String)
EndTable

'Main Program
BeginProg

'The Distance to Ground variable will need to determined manually on site. The
'Distance_to_Ground variable consists of both the distance to water surface, and
'the water depth. The distance to water surface can be measured by the RLS once
'it is properly installed. The distance to water surface is equal to Radar_Distance.
'The water depth value is equal to the distance between the riverbed and the water
'surface. This should be manually measured directly under the RLS sensor.

Distance_to_Ground = 152.50

Scan (5,Sec,0,0)

'The measurement interval of the RLS can be altered. Please be sure that the related
'data table reflects the measurement interval. Use concurrent measurement for the RLS.
If TimeIntoInterval(0,15,Min) OR Trigger_Measurement = True Then
  SDI12Recorder (RLS(),1,0,"MC!",1,0,0) 'Other Port options include C3, C5, and C7

'Calculations to determine Water Level
Radar_Distance = Radar_Distance * 100 'Convert from meters to centimeters
Water_Level = Distance_to_Ground - Radar_Distance
Trigger_Measurement = False
```

```
'Convert Numeric RLS Status Codes
```

```
If RLS(2) = 0 Then Radar_Status = "OK"
```

```
If RLS(2) = 2 Then Radar_Status = "No Target Recognized"
```

```
If RLS(2) = 4 Then Radar_Status = "Internal Error 4"
```

```
If RLS(2) = 8 Then Radar_Status = "Measurement Variance"
```

```
If RLS(2) = 16 Then Radar_Status = "SDI12 Interruption"
```

```
If RLS(2) = 32 Then Radar_Status = "Internal Error 32"
```

```
    CallTable RLS_Data
```

```
EndIf
```

```
NextScan
```

```
EndProg
```