

INSTRUCTION MANUAL



PS100 and CH100 Power Supply and Charging Regulators, A100 Null Modem Adapter, and A105 Additional 12 V Terminals Adapter

Revision: 4/09



Copyright © 2000-2009
Campbell Scientific, Inc.

WARRANTY AND ASSISTANCE

This equipment is warranted by CAMPBELL SCIENTIFIC (CANADA) CORP. ("CSC") to be free from defects in materials and workmanship under normal use and service for **twelve (12) months** from date of shipment unless specified otherwise. ***** **Batteries are not warranted.** ***** CSC's obligation under this warranty is limited to repairing or replacing (at CSC's option) defective products. The customer shall assume all costs of removing, reinstalling, and shipping defective products to CSC. CSC will return such products by surface carrier prepaid. This warranty shall not apply to any CSC products which have been subjected to modification, misuse, neglect, accidents of nature, or shipping damage. This warranty is in lieu of all other warranties, expressed or implied, including warranties of merchantability or fitness for a particular purpose. CSC is not liable for special, indirect, incidental, or consequential damages.

Products may not be returned without prior authorization. To obtain a Return Merchandise Authorization (RMA), contact CAMPBELL SCIENTIFIC (CANADA) CORP., at (780) 454-2505. An RMA number will be issued in order to facilitate Repair Personnel in identifying an instrument upon arrival. Please write this number clearly on the outside of the shipping container. Include description of symptoms and all pertinent details.

CAMPBELL SCIENTIFIC (CANADA) CORP. does not accept collect calls.

Non-warranty products returned for repair should be accompanied by a purchase order to cover repair costs.



CAMPBELL SCIENTIFIC
C A N A D A C O R P .

11564 - 149 street - edmonton - alberta - T5M 1W7
tel 780.454.2505 fax 780.454.2655

www.campbellsci.ca

PLEASE READ FIRST

About this manual

Please note that this manual was originally produced by Campbell Scientific Inc. (CSI) primarily for the US market. Some spellings, weights and measures may reflect this origin.

Some useful conversion factors:

Area: 1 in² (square inch) = 645 mm²

Length: 1 in. (inch) = 25.4 mm
1 ft (foot) = 304.8 mm
1 yard = 0.914 m
1 mile = 1.609 km

Mass: 1 oz. (ounce) = 28.35 g
1 lb (pound weight) = 0.454 kg

Pressure: 1 psi (lb/in²) = 68.95 mb

Volume: 1 US gallon = 3.785 litres

In addition, part ordering numbers may vary. For example, the CABLE5CBL is a CSI part number and known as a FIN5COND at Campbell Scientific Canada (CSC). CSC Technical Support will be pleased to assist with any questions.

PS100 Table of Contents

PDF viewers note: These page numbers refer to the printed version of this document. Use the Adobe Acrobat® bookmarks tab for links to specific sections.

1. General Description	1
2. Specifications	1
3. Wiring	2
4. A100 Null Modem Adapter	4
5. A105 12V Terminal Expansion Adapter	5

Figures

1. Wiring to Charger	3
2. Simplified Charging Circuit Schematic	4
3. Null Modem Connections	5
4. A105 Adapter	5

PS100 and CH100 Power Supply and Charging Regulators, A100 Null Modem Adapter, and A105 Additional 12 V Terminals Adapter

1. General Description

The PS100 is a 12-volt power supply that includes a charging regulator and a 7 amp hour battery. The CH100 is a charging regulator that is used with a Campbell Scientific battery pack such as the BP12 or BP24 or with a user-supplied battery. Charging power is typically supplied by an AC transformer or an unregulated solar panel.

The PS100 and CH100 each have one adapter connector that will allow connecting one of the following adapters.

The A100 Null Modem Adapter has two 9-pin connectors that provide a null modem for use in a site, without a datalogger. The A100 connects and powers two Campbell Scientific peripherals that would normally be connected to a datalogger. These peripherals are typically modems linking different communications technologies; e.g., telephone to radio.

The A105 Additional 12 V Terminals Adapter may be used to provide additional 12 V and ground terminals where the power supply is used to power several devices.

NOTE

To prevent people from getting burned, an ABS plastic cover [CSI #18688] sits on the heatsink of a PS100 or CH100. The cover is fastened to the heatsink via a #4-40 x .250 Pan Phillips screw [#395]. The cover must be removed to attach an A100 or A105 adapter. Some early models of the PS100 and CH100 did not include the cover and do not have a place to attach it.

2. Specifications

Input Voltage (CHG terminals)	15 to 28 VDC or 18 VAC RMS
Battery Connections	
Charging Output Voltage:	Temperature compensated float charge for 12 V Battery
Temperature Compensation Range:	-40 to +60°C
Charging Current Limit:	1.2 Amps typical

Power Out (+12 terminals)

Voltage: Unregulated 12 V from Battery
Current Limited w / 3 A Thermal Fuse: > 3 A @ < 20°C
3 A @ 20°C
2.1A @ 50°C
1.8 A @ 60°C

Battery Packs

Operating Temperature Range: -40 to +60°C
Capacity:
PS100 7 Amp hours
BP12 12 Amp hours
BP24 24 Amp hours

WARNING

These batteries are designed to be float charged. Permanent damage occurs and battery life is shortened if the battery is allowed to discharge below 10.5 volts.

AC Transformer: CSI Model No. 9591

Input Voltage: 120 VAC
Output Voltage: 18 VAC RMS
Output Current (max): 1.2 Amps RMS
Protection (automatic reset): 85°C thermal reset breaker
UL Approval: UL-1950

AC Transformer: CSI Model No. 14014

Input Voltage: 90 - 264 VAC; 47 - 63 Hz
Output Voltage: 18 VDC
Output Current (max): 1.3 Amps
UL Approved, File No.: E137895

PS100

Physical Specifications: 10.5 cm tall, 19 cm long,
7 cm wide

3. Wiring

An internal or external battery is connected to the charger by means of the INT (Internal) or EXT (External) connectors, as shown in Figure 1. An “external battery” cable is available for the charger. This cable connects another battery with the charger to provide power if the main battery is removed. The red lead connects to the positive battery terminal and the black lead connects to the negative terminal.

WARNING

Reversal of polarity of external battery will damage the PS100 or CH100.

It is possible to leave two batteries connected. The battery connections are diode isolated (Figure 2); however, if one of the batteries fail, it could draw all the charging current and the other battery will be discharged.

CAUTION

A battery **must** be attached for the charger to function correctly as a power supply.

The leads from the transformer or solar panel are connected to the CHG terminals. Polarity does not matter; either lead can be connected to either terminal.

The wires that connect power to the datalogger and/or peripherals are connected to the +12 and ground (\ominus) terminals.

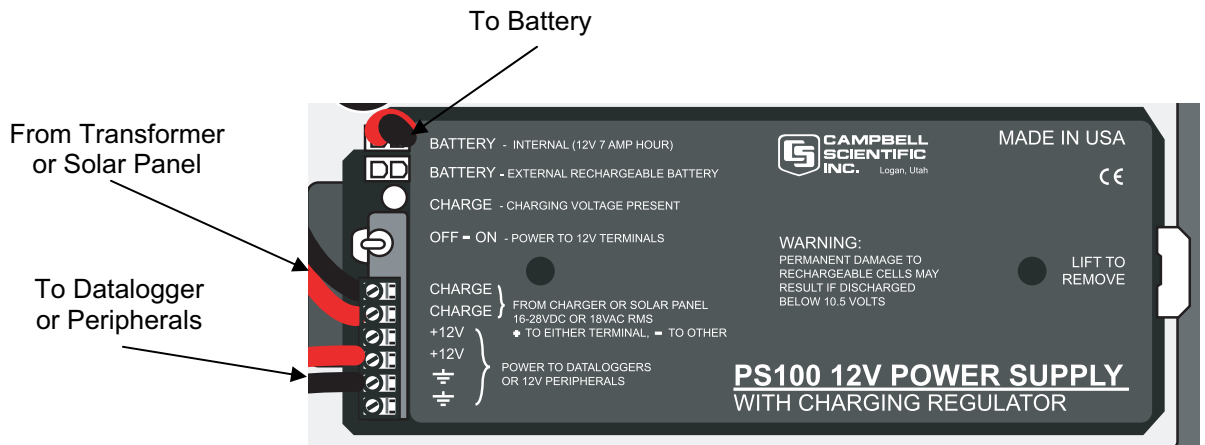

FIGURE 1. Wiring to Charger

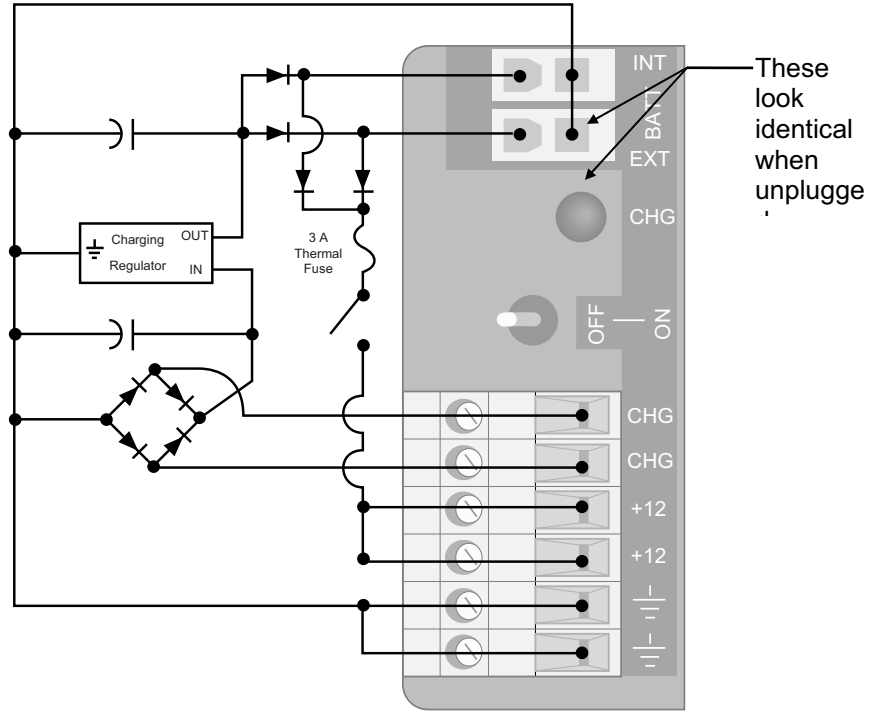

FIGURE 2. Simplified Charging Circuit Schematic

4. A100 Null Modem Adapter

The A100 has two 9-pin CS I/O ports with a null modem between them. The ports are used to connect two 9-pin devices that would normally be connected to the CS I/O port on a Campbell datalogger. The charger supplies 12 volts and 5 volts to the appropriate pins on the connector for powering the connected devices.

CAUTION

This cannot be used as a null modem between two RS-232 devices.

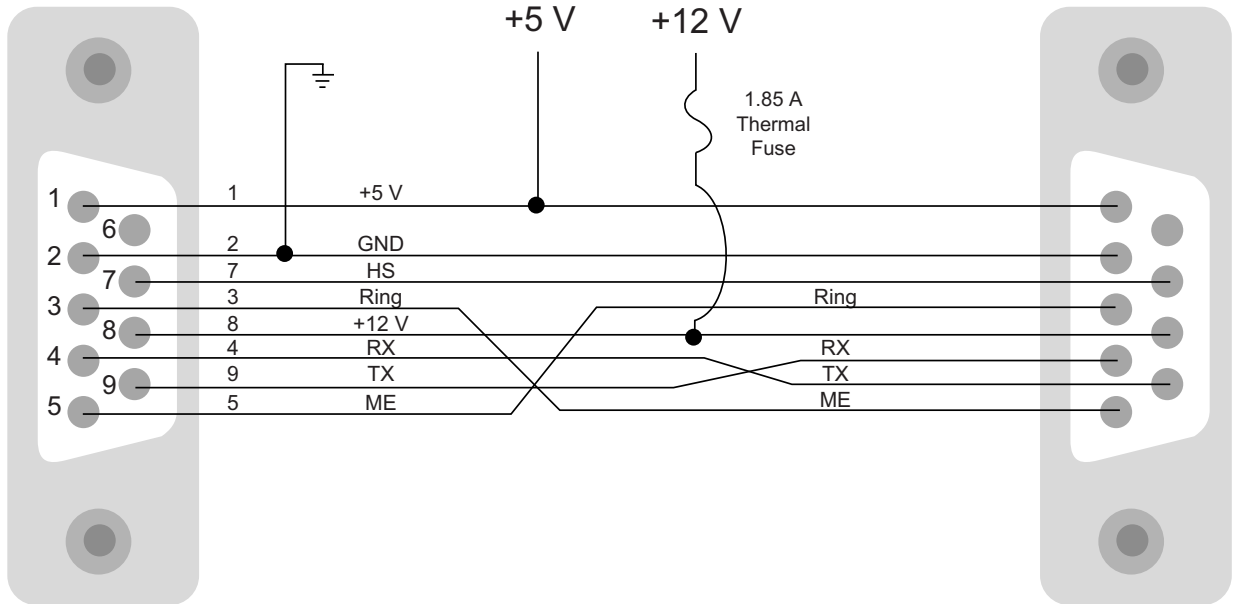

FIGURE 3. Null Modem Connections

5. A105 12V Terminal Expansion Adapter

The A105 adapter adds four 12-V terminals and four ground terminals to a CH100 or PS100 (see Figure 4). The extra terminals make it easier to wire multiple continuously powered 12-Vdc devices to the power supply.



FIGURE 4. A105 Adapter

Campbell Scientific Companies

Campbell Scientific, Inc. (CSI)

815 West 1800 North
Logan, Utah 84321
UNITED STATES
www.campbellsci.com • info@campbellsci.com

Campbell Scientific Africa Pty. Ltd. (CSAf)

PO Box 2450
Somerset West 7129
SOUTH AFRICA
www.csafrica.co.za • cleroux@csafrica.co.za

Campbell Scientific Australia Pty. Ltd. (CSA)

PO Box 444
Thuringowa Central
QLD 4812 AUSTRALIA
www.campbellsci.com.au • info@campbellsci.com.au

Campbell Scientific do Brazil Ltda. (CSB)

Rua Luisa Crapsi Orsi, 15 Butantã
CEP: 005543-000 São Paulo SP BRAZIL
www.campbellsci.com.br • suporte@campbellsci.com.br

Campbell Scientific Canada Corp. (CSC)

11564 - 149th Street NW
Edmonton, Alberta T5M 1W7
CANADA
www.campbellsci.ca • dataloggers@campbellsci.ca

Campbell Scientific Centro Caribe S.A. (CSCC)

300 N Cementerio, Edificio Breller
Santo Domingo, Heredia 40305
COSTA RICA
www.campbellsci.cc • info@campbellsci.cc

Campbell Scientific Ltd. (CSL)

Campbell Park
80 Hathern Road
Shepshed, Loughborough LE12 9GX
UNITED KINGDOM
www.campbellsci.co.uk • sales@campbellsci.co.uk

Campbell Scientific Ltd. (France)

Miniparc du Verger - Bat. H
1, rue de Terre Neuve - Les Ulis
91967 COURTABOEUF CEDEX
FRANCE
www.campbellsci.fr • info@campbellsci.fr

Campbell Scientific Spain, S. L.

Psg. Font 14, local 8
08013 Barcelona
SPAIN
www.campbellsci.es • info@campbellsci.es

Please visit www.campbellsci.com to obtain contact information for your local US or International representative.