

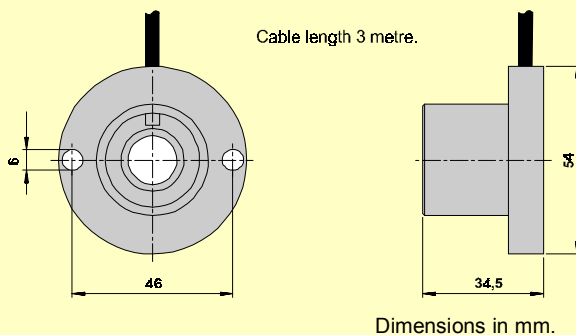

Specifications

Range	0 - 10.000 $\mu\text{mol}/\text{m}^2.\text{s}$
Sensitivity (nominal)	4 - 6 $\mu\text{V}/\mu\text{mol}/\text{m}^2.\text{s}$
Spectral range	400 - 700 nm
cut on	400 \pm 15 nm
cut off	700 \pm 15 nm
quantum response matching error (450 - 650 nm)	< 10%
Directional error (up to 80 degrees)	< 10%
Response time	less than 0.1 sec
Operating temperature	-30 $^{\circ}\text{C}$ to +70 $^{\circ}\text{C}$
Temperature dependence	< \pm 0.1 % / $^{\circ}\text{C}$

Dimensions



Recommended use:

PAR LITE is designed for outdoor measurement of photosynthetically active radiation (PAR) in natural daylight.

It has been specifically designed for:

- Agricultural meteorology
- Studies of crop growth

PAR LITE can be used under all weather conditions. The sensor measures the PAR received from the entire hemisphere.

PAR LITE uses a specially designed optical filter to provide a quantum response between 400 and 700 nm.

PAR LITE uses a photodiode sensor, which creates a voltage output that is proportional to the incoming radiation. Due to the unique design of the diffuser, its sensitivity is proportional to the cosine of the angle of incidence of the incoming radiation, allowing for accurate and consistent measurements.

PAR LITE is easy to use. It can be directly connected to voltmeter or data logger. By using the sensitivity a direct readout in $\mu\text{mol}/\text{m}^2.\text{s}$ can be derived. For each sensor the individual sensitivity is indicated on the instrument.

Spectral response

