



CAMPBELLSCIENTIFIC
CANADA CORP

11564 - 149 street - edmonton - alberta - T5M 1W7
tel 780.454.2505 fax 780.454.2655
www.campbellsci.ca



OBS-3+ and OBS300

Turbidity Sensors



OBS-3+ and OBS300 Turbidity Sensors



The OBS-3+ and OBS300 use OBS® technology to measure suspended solids and turbidity for up to 4000 NTUs. They are submersible sensors. With the stainless steel body, these turbidity sensors can be submerged in fresh water to a depth of 500 meters. With the titanium body, the sensors can be submerged in both fresh and salt water to a maximum depth of 1500 meters.

Applications

- Gage rivers and streams
- Monitor dredging and mining operations
- Control water quality in settling ponds and tanks
- Support sediment transport research
- Provide laboratory measurements

Features

- Provides a compact, low-power probe that is field proven
- Supports fresh water and salt water applications (salt water submersion requires titanium body)
- Compatible with all of our contemporary dataloggers as well as many retired dataloggers
- Contains an integral voltage clamp and optional 4–20 mA current loop
- Fitted with MCBH-5-FS, wet-pluggable connector—multiple mating cable length options available
- Offers an optional 5-point sedimentation calibration (must send Campbell Scientific a dry sample of sedimentation from the water that will be monitored)

OBS Technology and Model Description

The OBS3+ and the OBS300 use the innovative OBS method for monitoring suspended sediment and turbidity. With this method, the probe uses its optics to emit a near-infrared light into the water. It then measures the light that bounces back from the water's suspended particles. If an obstruction is in the emitted light's range, the light will scatter back and the turbidity reading will be too high.

The OBS-3+ has optics on the side of its body, which allows you to avoid obstructions above or below the probe (see graphic). The OBS300 has optics on the end of its body, which allows you to avoid obstructions around the sides of the probe.

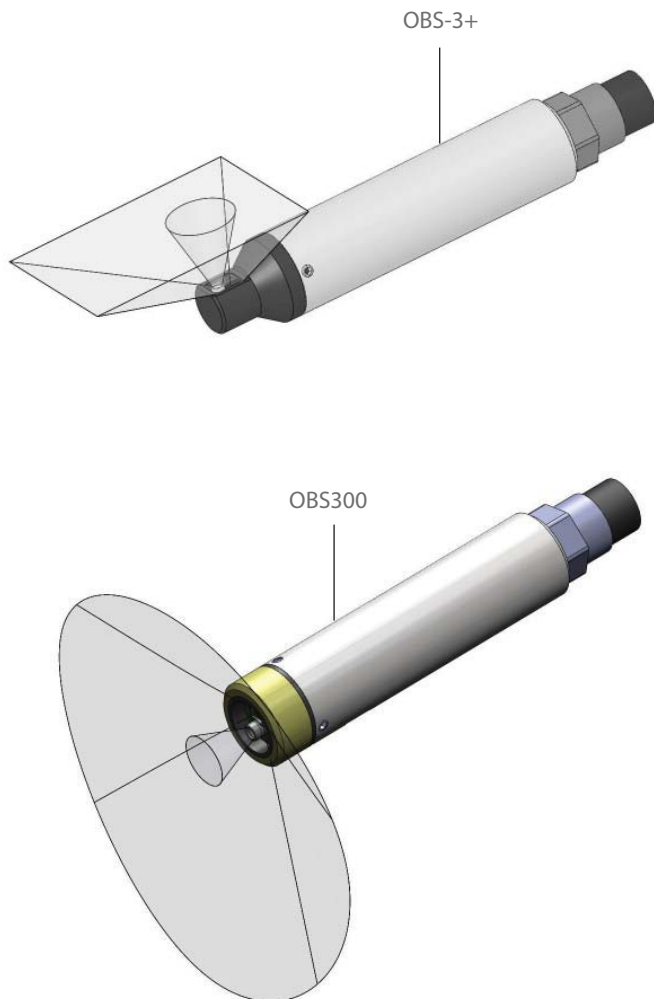

The emitted light and detector cones of the OBS-3+ and OBS300 are shown above.

Ordering Information

Turbidity Sensors

When ordering an OBS-3+ or OBS300, you must choose a body option, output option, and turbidity option. You will also need a cable to connect the sensor to a datalogger (see page 4). Mechanical wipers and other accessories are also listed on page 4.

OBS-3+ Turbidity Sensor with optics on side of its body.

OBS300 Turbidity Sensor with optics at the end of its body.

Body Options (choose one)

- SB** Stainless Steel Body (fresh water only; maximum submersion depth of 500 m)
- TB** Titanium Body (fresh or salt water; maximum submersion depth of 1500 m)

Output Options (choose one)

Each OBS sensor has two channels—one channel measures the lower turbidity range and the other channel measures the higher turbidity range. You must also choose a turbidity range (see below).

- 2.5** Supports our CR200(X)-series, CR510, or CR10(X) dataloggers; both channels have an output range of 0 to 2.5 V.
- 5** Supports our CR800, CR850, CR1000, CR3000, CR5000, and CR9000(X) dataloggers; both channels have an output range of 0 to 5 V.
- 20** Low channel has an output range of 4-20 mA, and the high channel has an output range of 0 to 5 V. A CURS100 is required for our dataloggers to read the 4-20 mA output.

Turbidity Range Options (choose one)

When the output option is -2.5 or -5, you should order a range where the high channel will capture all high readings and the low range will capture most readings. When the output option is -20, the channel with the 4-20 mA output measures the lower turbidity range, and the channel with the 0 to 5 V output measures the upper turbidity range.

- T1** Measures the lower range of 0 to 250 NTUs or higher range of 0 to 1000 NTUs.
- T2** Measures the lower range of 0 to 500 NTUs or higher range of 0 to 2000 NTUs.
- T3** Measures the lower range of 0 to 1000 NTUs or higher range of 0 to 4000 NTUs.
- T4** Measures the lower range of 0 to 2000 NTUs or higher range of 0 to 4000 NTUs.
- T5** Measures the range of 0 to 4000 NTUs on both channels. When the low channel has a 4-20 mA output (i.e., OBS-3+-20 or OBS300-20), the turbidity sensor can measure up to 4000 NTUs.

Ordering Information Continued

Cables for Datalogger Attachment

Several cable choices are offered for attaching the OBS sensor to the datalogger. The cables differ in their length.

21094	Cable with 5-m (16 ft) length
21307	Cable with 10-m (32 ft) length
21308	Cable with 15-m (49 ft) length.
21309	Cable with 20-m (66 ft) length.
21310	Cable with 25-m (82 ft) length.
21311	Cable with 30-m (98 ft) length.

Mechanical Wipers for the OBS-3+

A wiper can help ensure accurate measurements by preventing algae and other fouling from covering the lens of the OBS-3+.

HYDRO-WIPER-C	Battery-powered, mechanical wiper with integrated timer and 1 m (3 ft) cable. This wiper is intended for stand-alone operation.
HYDRO-WIPER-D	Datalogger-controlled wiper with a 5-m (16 ft) cable. It uses the datalogger's power supply. This wiper is recommended when using a datalogger.
HYDRO-WIPER-D-L	Datalogger-controlled wiper with user-specified cable length; enter length, in meters, after the -L. A user-specified cable length takes more time to manufacture; delivery time is 4 to 6 weeks. This wiper uses the datalogger's power supply.

Other Accessories

21098	OBS-3+ or OBS300 Carrying Case (holds 2)
20915	5-Point Sedimentation Calibration (must send Campbell Scientific a dry sample of sedimentation from the water that will be monitored)
CURS100	Current Shunt Module is required for our dataloggers to read a 4-20 mA signal (output option -20)

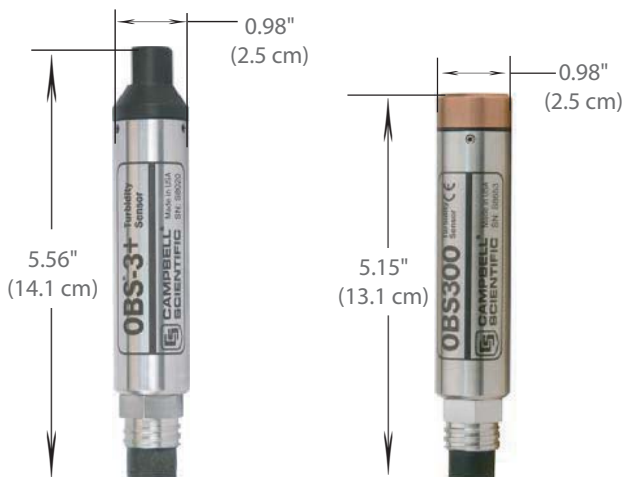

Specifications

Maximum Depth	
Stainless-Steel Body:	500 m (1640.5 ft)
Titanium Body:	1500 m (4921.5 ft)

Drift: <2% per year

Maximum Data Rate: 10 Hz

Input Voltage	
Voltage Output:	5 to 15 Vdc
Current Output:	9 to 15 Vdc

Typical Current Drain	
Voltage Output:	15 mA
Current Output:	45 mA

Operating Wavelength: 850 nm ±5 nm

Daylight Rejection: -28 dB (re:48 mW cm⁻²)

Optical Power: 2000 µW

Ranges

Turbidity: see Turbidity Range Options on page 3

Maximum Concentration*

Mud:	5,000 mg/l to 10,000 mg/l
Sand:	50,000 mg/l to 100,000 mg/l

Accuracy

Turbidity: 2% of reading or 0.5 NTU (whichever is larger)

Concentration

Mud:	2% of reading or 1 mg/l (whichever is larger)
Sand:	4% of reading or 10 mg/l (whichever is larger)

Physical

Housing Material:	316 stainless steel or titanium
Connector:	MCBH-5-FS, wet-pluggable
Weight:	0.4 lbs (181.4 g)
Diameter:	0.98" (2.5 cm)
Height	
OBS3+:	5.56" (14.1 cm)
OBS300:	5.15" (13.1 cm)

*Maximum concentration depends on sediment size, particle shape, and reflectivity.

