

INSTRUCTION MANUAL



LLAC4 Four-Channel, Low-Level AC Conversion Module

Revision: 6/06



Copyright © 2004-2006
Campbell Scientific, Inc.

WARRANTY AND ASSISTANCE

This equipment is warranted by CAMPBELL SCIENTIFIC (CANADA) CORP. ("CSC") to be free from defects in materials and workmanship under normal use and service for **twelve (12) months** from date of shipment unless specified otherwise. ***** **Batteries are not warranted.** ***** CSC's obligation under this warranty is limited to repairing or replacing (at CSC's option) defective products. The customer shall assume all costs of removing, reinstalling, and shipping defective products to CSC. CSC will return such products by surface carrier prepaid. This warranty shall not apply to any CSC products which have been subjected to modification, misuse, neglect, accidents of nature, or shipping damage. This warranty is in lieu of all other warranties, expressed or implied, including warranties of merchantability or fitness for a particular purpose. CSC is not liable for special, indirect, incidental, or consequential damages.

Products may not be returned without prior authorization. To obtain a Return Merchandise Authorization (RMA), contact CAMPBELL SCIENTIFIC (CANADA) CORP., at (780) 454-2505. An RMA number will be issued in order to facilitate Repair Personnel in identifying an instrument upon arrival. Please write this number clearly on the outside of the shipping container. Include description of symptoms and all pertinent details.

CAMPBELL SCIENTIFIC (CANADA) CORP. does not accept collect calls.

Non-warranty products returned for repair should be accompanied by a purchase order to cover repair costs.



CAMPBELL SCIENTIFIC
C A N A D A C O R P .

11564 - 149 street - edmonton - alberta - T5M 1W7
tel 780.454.2505 fax 780.454.2655

www.campbellsci.ca

LLAC4 Table of Contents

PDF viewers note: These page numbers refer to the printed version of this document. Use the Adobe Acrobat® bookmarks tab for links to specific sections.

1. General Description.....	1
2. Specifications	2
3. Measurements.....	2
4. Wiring.....	3
5. Program Examples	4

Figures

1. LLAC4 Four-Channel, Low-Level AC Conversion Module.....	1
2. LLAC to TTL	3

Tables

1. Sensor Output Frequencies.....	2
2. Control Port Compatibility	3

LLAC4 Four-Channel, Low-Level AC Conversion Module

1. General Description

The LLAC4 is a peripheral device used to increase the number of low-level AC signals a datalogger can monitor. The module enables four datalogger control ports to emulate pulse-counting channels by converting the low-level AC signals to the logic levels datalogger control ports require.

The LLAC4 is often used to measure up to four anemometers, and is especially useful for wind profiling applications. Compatible wind sensors include, but are not limited to, the 05103 Wind Monitor, 05106 Wind Monitor-MA, 05305 Wind Monitor-AQ, 03001 Wind Sentry Set, and 03101 Wind Sentry Anemometer.



FIGURE 1. LLAC4 Four-Channel, Low-Level AC Conversion Module

2. Specifications

Power:	8 to 16 Vdc 0.1 mA @ 12 Vdc										
Signal Conditioning:	Minimum AC Input Voltage versus Output Square Wave Frequency:										
	<table border="0"> <tr> <td>Input Sine Wave (mV RMS)</td> <td>Output Square Wave Range (Hz)</td> </tr> <tr> <td>20</td> <td>1.0 to 20</td> </tr> <tr> <td>200</td> <td>0.5 to 200</td> </tr> <tr> <td>2000</td> <td>0.3 to 10,000</td> </tr> <tr> <td>5000</td> <td>0.3 to 20,000</td> </tr> </table>	Input Sine Wave (mV RMS)	Output Square Wave Range (Hz)	20	1.0 to 20	200	0.5 to 200	2000	0.3 to 10,000	5000	0.3 to 20,000
Input Sine Wave (mV RMS)	Output Square Wave Range (Hz)										
20	1.0 to 20										
200	0.5 to 200										
2000	0.3 to 10,000										
5000	0.3 to 20,000										
AC Coupling Removes DC Offset:	up to $\pm 0.5V$										
Input Hysteresis:	16 mV @ 1 Hz										
Max AC Input Voltage:	$\pm 20 V$										
Dimensions:	3.1" W x 2.1" H x 1.0" D (8.0 x 5.4 x 2.5 cm) 4.5" W x 2.1" H x 1.0" D (11.2 x 5.4 x 2.5 cm) including base mounting flange										
Cable Length	2 ft (0.6 m)										
Weight:	3.2 oz (92 g)										

3. Measurements

Sensors, such as anemometers, may produce a sinusoidal AC signal output where the frequency is proportional to the speed of rotation. This AC signal is induced in a stationary coil by a magnet mounted on a rotating shaft.

The datalogger's pulse channels can read this low-level AC signal directly. The LLAC4 has signal conditioning to convert the low-level AC to a 0 to 5 volt square wave that can be measured on the datalogger's control ports. The frequency response of the LLAC4 is the same as the low-level AC on the pulse inputs.

Typically, propeller type anemometers operate at higher frequencies than cup anemometers at the same wind speed (see Table 1).

TABLE 1. Sensor Output Frequencies		
Sensor	Output @ 50m/s	Type
05103	510Hz	Propeller
03101	67Hz	Cup

The datalogger must also be able to read these high frequency pulses on its control ports. Table 2 shows some common dataloggers and their compatible control port specifications.

Datalogger	Input (Hz)	Control Port	Measurement Type
CR1000 CR3000	400,000	C1,C2... C8	High Frequency
CR800	400,000	C1,C2,C3,C4	High Frequency
CR23X	2,500	C5,C6,C7,C8	High Frequency
CR200	1,000	P_LL,P_SW,C1,C2	High Frequency
CR10X	40	C6,C7,C8	Switch Closure

Comparing Table 1 to Table 2 suggests that the CR10X may not be able to read either type of anemometer in high wind situations. However, all other dataloggers would be appropriate choices.

4. Wiring

Most sensors that have a low-level AC output will have three wires: signal, reference, and drain. The signal wire should go to P1 – P4 on the LLAC4 and the reference and drain wires to a \varnothing on the LLAC4. The LLAC4 also requires that 12 V be applied to its 12 V terminal and G. This power should come from the datalogger or the datalogger’s power supply.

A low-level AC signal on P1 will be converted to a 0-5 V square wave on the D1 terminal. D1 can be wired to an appropriate datalogger control port that can make high frequency measurements.

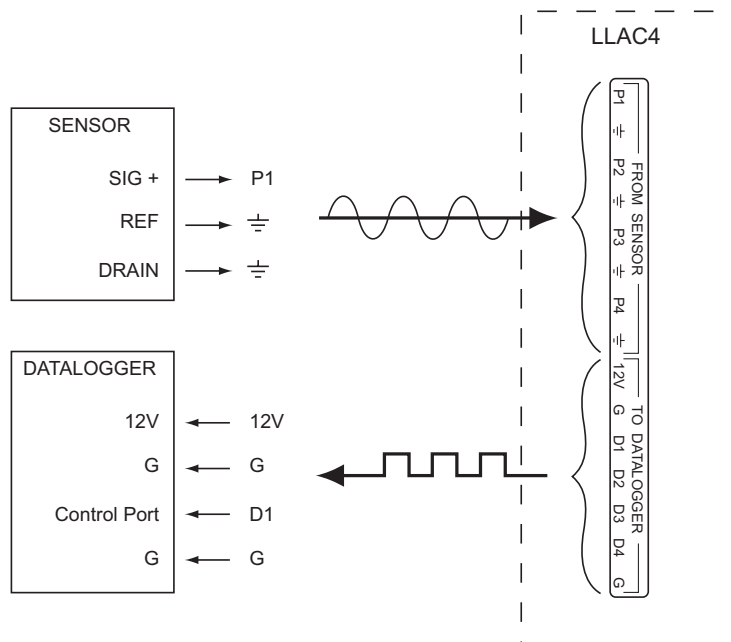

FIGURE 2. LLAC to TTL

5. Program Examples

Using the CR1000, let's measure four different wind speed sensors that produce low-level AC signals. These will include the RM Young 05103, 05106, 05305, propeller type anemometers, and RM Young 03101 cup anemometer. Program examples are provided for both the CR1000 and the CR200.

		Wiring				
Sensor		LLAC4		CR1000	CR200	
05103-L	Sig +	Red	P1			
	Ref	Black	⊥			
	Drain	Clear	⊥			
05106-L	Sig +	Red	P2			
	Ref	Black	⊥			
	Drain	Clear	⊥			
05305-L	Sig +	Red	P3			
	Ref	Black	⊥			
	Drain	Clear	⊥			
03101-L	Sig +	Black	P4			
	Ref	White	⊥			
	Drain	Clear	⊥			
			12 V	Red	12 V	Battery +
			G	Black	G	G
			D1	White	C5	PLL
			D2	Green	C6	C1/SDI-12
			D3	Yellow	C7	C2
			D4	Blue	C8	P_SW
			G	Clear	G	G

CR1000 Example Program

```
'CR1000 Series Datalogger
'LLAC4 Sample Program
'Record 10-minute average wind speed in m/s for:
'1 RM Young 05103-L Wind Monitor Anemometer
'1 RM Young 05106-L Marine Wind Monitor Anemometer
'1 RM Young 05305-L AQ Wind Monitor Anemometer
'1 RM Young 03101-L Wind Sentry Anemometer

'Declare Public Variables
Public RMY05103WS
Public RMY05106WS
Public RMY05305WS
Public RMY03101WS

'Define Data Tables
DataTable (WindSpd,1,-1)
  DataInterval (0,10,min,0)
    Average (1,RMY05103WS,FP2,False)
    Average (1,RMY05106WS,FP2,False)
    Average (1,RMY05305WS,FP2,False)
    Average (1,RMY03101WS,FP2,False)
EndTable
```

```

'Main Program
BeginProg
Scan (1,Sec,0,0)
    PulseCount (RMY05103WS,1,15,0,1,0.098,0.0)
    PulseCount (RMY05106WS,1,16,0,1,0.098,0.0)
    PulseCount (RMY05305WS,1,17,0,1,0.1024,0.0)
    PulseCount (RMY03101WS,1,18,0,1,0.750,0.20)
    If RMY03101WS < 0.21 Then
        RMY03101WS = 0.0
    EndIf
    CallTable WindSpd
NextScan
EndProg

```

CR200 Example Program

```

'CR200 Series Datalogger
'LLAC4 Sample Program
'Record 10-minute average wind speed in m/s for:
'1 RM Young 05103-L Wind Monitor Anemometer
'1 RM Young 05106-L Marine Wind Monitor Anemometer
'1 RM Young 05305-L AQ Wind Monitor Anemometer
'1 RM Young 03101-L Wind Sentry Anemometer

'Declare Public Variables
Public RMY05103WS
Public RMY05106WS
Public RMY05305WS
Public RMY03101WS

'Define Data Tables
DataTable (WindSpd,1,-1)
    DataInterval (0,10,min)
        Average (1,RMY05103WS,False)
        Average (1,RMY05106WS,False)
        Average (1,RMY05305WS,False)
        Average (1,RMY03101WS,False)
EndTable

'Main Program
BeginProg
Scan (1,Sec)
    PulseCount (RMY05103WS,P_LL,0,1,0.098,0.0)
    PulseCount (RMY05106WS,C1,0,1,0.098,0.0)
    PulseCount (RMY05305WS,C2,0,1,0.1024,0.0)
    PulseCount (RMY03101WS,P_SW,0,1,0.750,0.20)
    If RMY03101WS < 0.21 Then
        RMY03101WS = 0.0
    EndIf
    CallTable WindSpd
NextScan
EndProg

```

Campbell Scientific Companies

Campbell Scientific, Inc. (CSI)

815 West 1800 North
Logan, Utah 84321
UNITED STATES
www.campbellsci.com
info@campbellsci.com

Campbell Scientific Africa Pty. Ltd. (CSAf)

PO Box 2450
Somerset West 7129
SOUTH AFRICA
www.csafrica.co.za
sales@csafrica.co.za

Campbell Scientific Australia Pty. Ltd. (CSA)

PO Box 444
Thuringowa Central
QLD 4812 AUSTRALIA
www.campbellsci.com.au
info@campbellsci.com.au

Campbell Scientific do Brazil Ltda. (CSB)

Rua Luisa Crapsi Orsi, 15 Butantã
CEP: 005543-000 São Paulo SP BRAZIL
www.campbellsci.com.br
suporte@campbellsci.com.br

Campbell Scientific Canada Corp. (CSC)

11564 - 149th Street NW
Edmonton, Alberta T5M 1W7
CANADA
www.campbellsci.ca
dataloggers@campbellsci.ca

Campbell Scientific Ltd. (CSL)

Campbell Park
80 Hathern Road
Shepshed, Loughborough LE12 9GX
UNITED KINGDOM
www.campbellsci.co.uk
sales@campbellsci.co.uk

Campbell Scientific Ltd. (France)

Miniparc du Verger - Bat. H
1, rue de Terre Neuve - Les Ulis
91967 COURTABOEUF CEDEX
FRANCE
www.campbellsci.fr
campbell.scientific@wanadoo.fr

Campbell Scientific Spain, S. L.

Psg. Font 14, local 8
08013 Barcelona
SPAIN
www.campbellsci.es
info@campbellsci.es