



Campbell Scientific offers a variety of instrument mounts to attach sensors and peripherals to our light-weight tripods (CM110, CM115, CM120), galvanized-steel tripods (CM6, CM10), and towers (UT10, UT20, UT30). This equipment includes crossarms, brackets, solar radiation sensor mounts, and radiation shields.

## U-Bolts

U-bolts are often included with our mounts to attach them to a tripod or tower mast, tower leg, sensor mounting pipe, antenna, or user-supplied pole. The u-bolts support the following outer diameters (OD):

U-bolt Description	Nominal Pipe Size	Outer Diameter (OD) Range
1.5 in.	0.75 to 1 in.	1.0 to 1.5 in. (2.54 to 3.81 cm)
2 in.	1 to 1.5 in.	1.3 to 2.1 in. (3.3 to 5.33 cm)
2 in. with plastic v-block	0.75 to 1.5 in.	1.0 to 2.1 in. (2.54 to 5.33 cm)

## Crossarms and Crossarm Bracket

### CM200-Series Crossarms

The CM202, CM204, and CM206 crossarms place sensors a few feet away from the midline of the tripod or tower, thereby reducing the effects of the tripod or tower on the sensor's measurement. These crossarms consist of a 1-in. IPS anodized aluminum pipe and a CM210 bracket that attaches to the tripod or tower. Sensors are mounted to the end of the crossarm using an appropriate mount such as a CM220 Right Angle Mounting Bracket. A u-bolt mounting scheme allows customers to place the crossarm at the optimal measurement height for the sensor.

The CM202, CM204, and CM206 differ in their length and the number of sensors that can be attached to them; one sensor can be attached to the CM202 and up to two sensors can be attached to the CM204 and CM206.

SPECIFICATIONS			
	CM202	CM204	CM206
Length	2 ft (0.6 m)	4 ft (1.3 m)	6 ft (1.8 m)
OD	1.31 in. (3.33 cm)	1.31 in. (3.33 cm)	1.31 in. (3.33 cm)
Weight	2.3 lbs (1.04 kg)	3.65 lbs (1.66 kg)	5 lbs (2.27 kg)



A CM206 crossarm is mounted atop this UT30 30 ft tower. On each end of the crossarm, a CM220 bracket is used to attach a 27106T vertical anemometer. Two 43502 Aspirated Radiation Shields are also fastened to a leg of the tower.

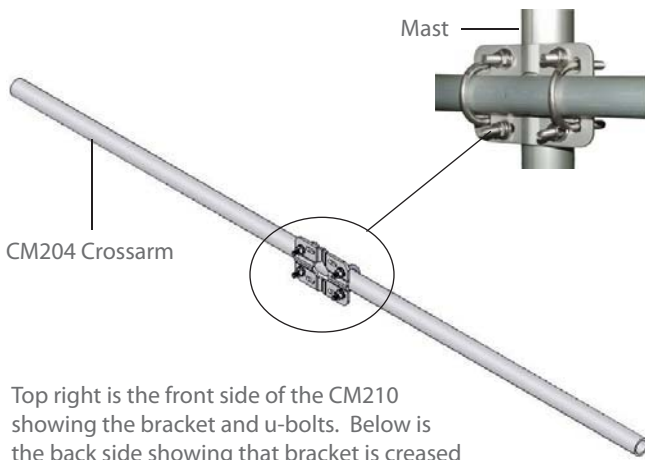

Top right is the front side of the CM210 showing the bracket and u-bolts. Below is the back side showing that bracket is creased to allow pipes of varying diameters to seat snugly in it.

### CM210 Crossarm Mounting Kit

The CM210 is included with our CM202, CM204, and CM206 crossarms but may also be ordered separately. When attaching a crossarm to a tower, purchasing a second CM210 may be desirable to secure the crossarm to two of the three tower legs. The CM210 is shipped with two 1.5-in. u-bolts and two 2-in. u-bolts allowing it to be attached to any of our tripods or towers.

SPECIFICATIONS	
<b>Mounting Bracket Material</b>	304 stainless steel bracket, with stainless-steel u-bolts and hardware
<b>Weight</b>	1.45 lbs (0.66 kg)
<b>Dimensions</b>	4 x 4.75 x 0.25 in. (10.2 x 12.07 x 0.64 cm)

## General Mounts



Wind sets are attached to CM200-series crossarms either using a NU-RAIL fitting (shown above) or the CM220 mounting bracket (shown below).

### NU-RAIL® Slip-On Crossover Fittings

NU-RAIL Slip On Offset Crossover Fittings are an option for connecting a sensor with a vertical pipe mount (e.g., most wind sensors) to a CM200-series crossarm. Campbell Scientific offers two sizes of NU-RAIL fittings. The 1049 NU-RAIL is used for sensors that have a 0.75-in. IPS mounting pipe, and the 17593 is used for sensors that have a 1-in. IPS mounting pipe (see below).

NU-RAIL/Sensor Compatibility	
Sensors with 0.75-in. IPS Pipe	Sensors with 1-in. IPS Pipe
014A Anemometer, 03101 Anemometer, 27106T Vertical Anemometer	024A Wind Vane, 034B Wind Set, 03002 Wind Sentry Set, 05103 Wind Monitor, 05103-45 Alpine Wind Monitor, 05106 Wind Monitor Marine, 05305 Wind Monitor-AQ

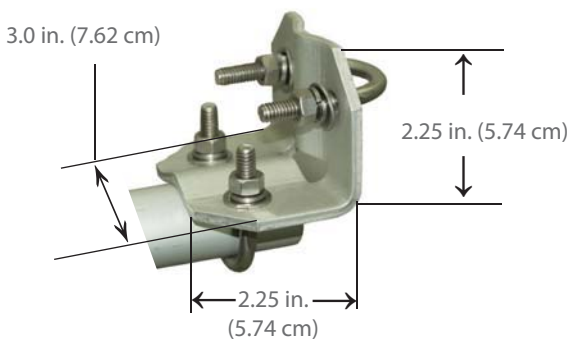

A closeup of the CM220 Right Angle Mounting Bracket shows the construction and crossarm attachment.

### CM220 Right Angle Mounting Bracket

The CM220 Right-Angle Mounting Bracket is another option for connecting a sensor with a vertical pipe mount to a CM200-series crossarm or a user-supplied pipe. It includes two 1.5-in. u-bolts.

### CM216 Apex Sensor Mount

The CM216 provides a 0.75-in. or 1-in. IPS mounting pipe (1.05-in. or 1.32-in. OD) that extends above the mast. It allows a sensor with a 1.0-in. or 1.32-in. OD fitting (typically a wind sensor) to be attached to the top of a stainless steel CM110, CM115, or CM120 tripod without a crossarm. Please note that a lightning rod cannot be used when this mount attaches a Wind Monitor atop the tripod's mast. Therefore the CM216 is only recommended for mounting a Wind Monitor if the deployment is short-term.

### CM230 Adjustable Inclination Mount

The CM230 is primarily used with directional (Yagi) antennas, but can also be used with sensors that need to be pointed at a specific target (e.g., the SI-111, SR50A, or LI7500). When using the CM230, fix the declination of the antenna or sensor by tightening a 2-in. u-bolt that mounts on the mast or user-supplied pipe. The inclination is then adjusted with a 1.5-in. u-bolt and nuts. The CM230 weighs 0.75 lbs (0.34 kg); dimensions are 3.0 x 3.75 x 3.5 in. (7.62 x 9.53 x 8.89 cm).

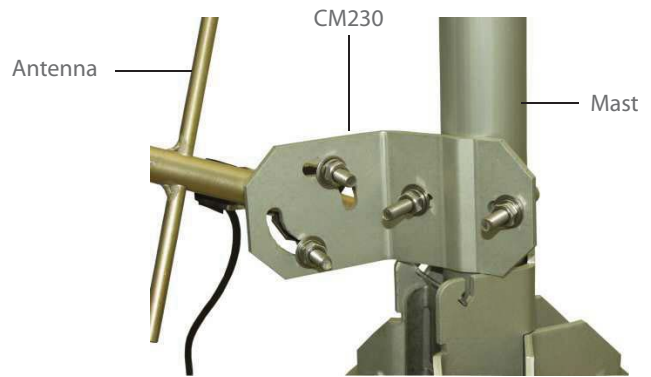

A CM230 supporting a Yagi antenna is attached to a mast. Only the first cross-element of the Yagi antenna is shown.

### CM235 Magnetic Mounting Stand

The CM235 attaches a device with a magnetic base to a crossarm or mast via a 2-in. u-bolt with a plastic v-block. Devices that have a magnetic base include our GPS16X-HVS Geographic Position Receiver, GPS antennas, and some short-range omnidirectional antennas. The CM235 weighs 0.7 lbs (0.32 kg).

## Solar Radiation Mounts

### Leveling Bases

Campbell Scientific offers two leveling bases that support different sensors. The LI2003S leveling base supports the LI200X and LI190SB probes, and the 18356 supports the CS300 probe. Both leveling bases use a bubble level and three adjustable leveling screws to level the sensor. The CMP3 and LP02 pyranometers include their own bubble level and leveling screws allowing them to be attached directly to the CM225 Solar Sensor Mounting Stand (see below).

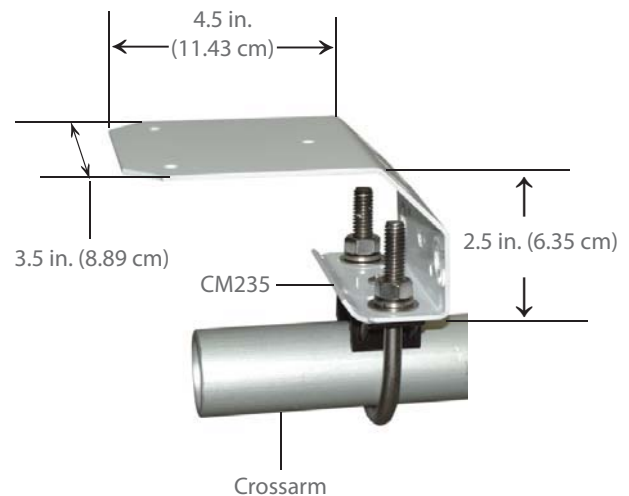

The three holes on the top plate of the CM235 are for mounting the device's magnetic base.

### CM225 Solar Sensor Mounting Stand

The CM225 mounting stand includes one 2-in. u-bolt with plastic v-block for attaching a solar radiation sensor to a crossarm or mast. Compatible sensors are the LI200X, LI190SB, CMP3, LP02, and CS300. The CMP3 and LP02 attach directly to the CM225. A leveling base (LI2003S or 18356) attaches the other sensors to the CM225. It weighs 0.75 lbs (0.34 kg); dimensions are 3.5 x 4.5 x 2.5 in. (8.9 x 11.3 x 6.4 cm).

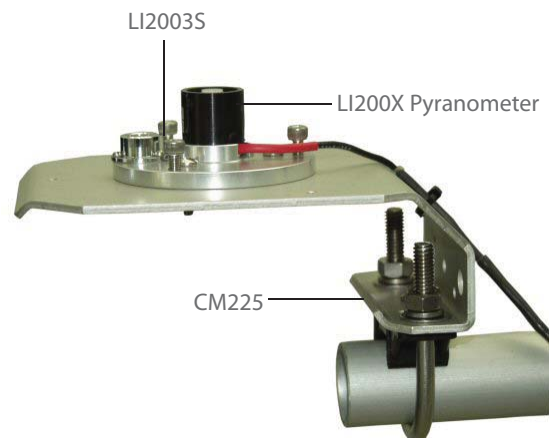

The CM225's u-bolt is placed in the holes on the bottom of the bracket for attachment to a crossarm. An LI2003S and a LI200X reside on the CM225.

### 26120 Net Radiation Sensor Mounting Kit

The 26120 Net Radiation Sensor Mounting Kit is used to attach a NR-LITE, CNR4, or CNR2 sensor to a vertical pipe or to a CM200-series crossarm. It includes adjustment screws to level the radiation sensor. The sensor should be mounted at least 1.5 m above the ground to avoid shading effects and to promote spatial averaging. Campbell Scientific recommends mounting our net radiation sensors at least 25 ft away from other structures in the monitoring system.

## Radiation Shields for Temperature and Temperature/RH Probes

### *Naturally-Aspirated Radiation Shields*

Campbell Scientific offers six-plate, 10-plate, and 14-plate naturally-aspirated radiation shields. The diameter of each plate is 4.7 in. (11.9 cm). Their louvered construction allows air to pass freely through the shield, thereby keeping the probe at or near ambient temperature. These radiation shields mount to a crossarm, mast, or tower leg via a 2-in. u-bolt with a plastic v-block.

The 41303-5A is our six-plate shield that weighs 0.9 lbs (0.41 kg) and has a 4.5-in. (11.4 cm) height. It can house a 107, 108, 109, CS215, or HMP50 probe.

The 41003-5 is our 10-plate shield that weighs 1.3 lbs (0.59 kg) and has an 8.0-in. (20.3 cm) height. It typically houses an HMP45C probe, but can also house a 107, 108, 109, HMP50, HMP155A, or 43502 probe. The 41322 Adapter Plate is required to install a 107, 108, or 109 probe. For the HMP50 probe, a 41322 Adapter Plate can be used to mount the sensor in the lower part of the shield. Alternatively, a 41381 extension tube and the 6637 split nut plug can be used to mount the HMP50 in a higher part of the shield. The 6637 split nut plug is required to mount the 43347 RTD.

The 41005-5 is our 14-plate shield used to house and protect the HMP155A Temperature and RH Probe.

### *Fan-Aspirated Radiation Shield*

R. M. Young's 43502 Aspirated Radiation Shield typically houses the 43347 R. M. Young RTD Temperature Probe (other temperature sensors may also fit inside this shield). The shield employs concentric downward facing intake tubes and a small canopy shade to isolate the temperature probe from direct and indirect radiation. A brushless 12 Vdc blower motor pulls ambient air into the shield and across the probe to reduce radiation errors. This allows temperature to be measured with an RMS error of less than  $\pm 0.2^{\circ}\text{C}$ . The blower operates off a 115 Vac to 12 Vdc transformer that is included with the shield.

The 43502 shield attaches to a crossarm, mast, or tower leg via a 2-in. u-bolt with a plastic v-block. Another CM210 Crossarm Mounting Kit is often desirable to attach the crossarm to two tower legs—providing additional stability. The 43502 has a 13-in. (33 cm) length and an 8-in. (20 cm) diameter.

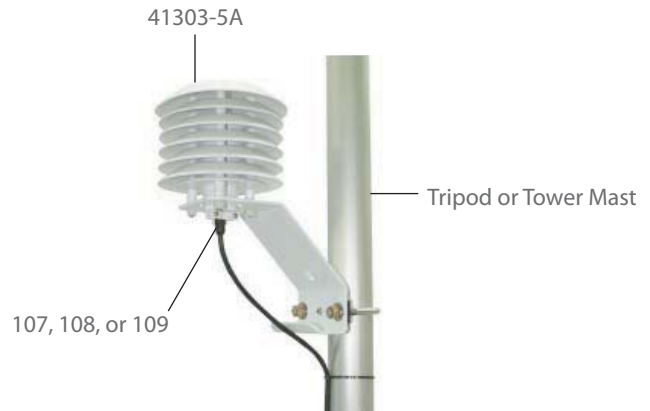

The u-bolt is placed in the holes on the side of the bracket to allow the 41303-5A to be attached to a mast or vertical pole.

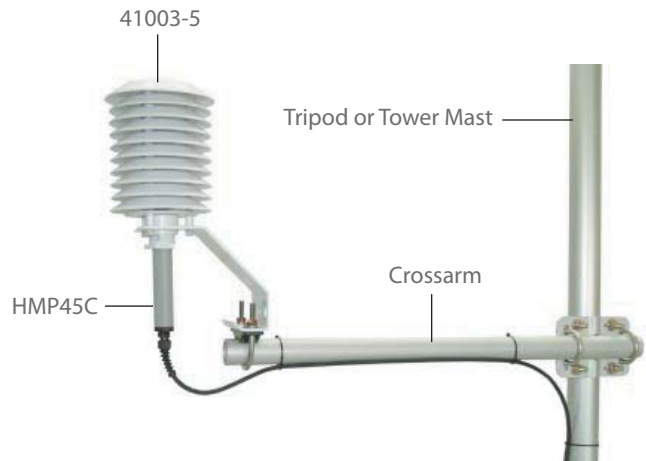

The u-bolt is placed in the holes on the bottom of the bracket for attachment to a crossarm.

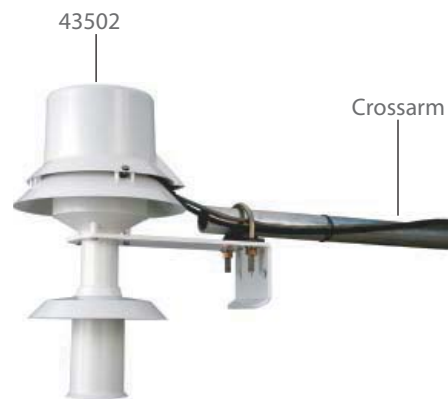

This 43502 is mounted to a crossarm. The UT30 tower on page one has two 43502 shields mounted to its leg.

