



CVF 3 Ventilation Unit

FOR IMPROVEMENT OF THE RELIABILITY AND ACCURACY OF RADIOMETER MEASUREMENTS

Easy to install and low maintenance
Can be used under all weather conditions

Reduces frequency of dome cleaning
Improves stability of measurements

INTRODUCTION

Ventilation of radiometers improves the reliability and accuracy of the measurement by reducing dust, raindrops and dew on the dome, which would otherwise affect the measurement. It stabilises the temperature of the radiometer near to that of the ambient air and suppresses the thermal offsets which are produced by cooling down the domes under calm clear sky conditions or by dome heating due to absorption of solar radiation.

CVF 3 Ventilation Unit is a low maintenance ventilation unit with a fan and inlet filter that provides a flow of clean air over the dome of a radiometer. Integrated heaters allow the air to be warmed when necessary.

The fan of the CVF 3 runs continuously to reduce dust and dirt settling, to dissipate rain drops and to stabilise the dome temperature. The tachometer output from the fan gives two pulses per revolution and allows remote monitoring of the fan operation using a data logger.

Two levels of integrated heating are available that can be switched on by the operator when required.

5 Watt heating is used under normal conditions to raise the temperature of the dome slightly above ambient to prevent the formation of dew and frost. 10 Watt heating for more extreme climates melts snow and ice.

CVF 3 features the waterproof connector and signature yellow cable that are used in our other instruments. This makes installation and servicing easier. Cable lengths of 10, 25 and 50m are available or it can be supplied with the connector plug only, for the customer to fit their own cable.

CVF 3 replaces the successful and widely used CV 2 ventilation unit.

Applications

CVF 3 is designed to operate under all weather conditions and is easy to use. The only part that needs maintenance is the removable air inlet filter, which should be checked at regular intervals and cleaned or replaced when necessary.

A ventilation system does not prevent the radiometer dome becoming dirty, but it can reduce the frequency of cleaning. Typical applications are in locations where frost and snow are frequent or where the site is unmanned and it is necessary to reduce the need for cleaning of the domes.

In top level solar radiation monitoring networks, such as the Baseline Surface Radiation Network (BSRN) of the World Meteorological Organisation, ventilation of pyranometers and pyrgeometers is mandatory.

Specifications	
Ventilator fan power	5 W continuously
Heater power (selectable)	5 W and 10 W
Operating temperature	-40 to +70 °C
Air temperature rise caused by CVF 3	< 0.25 K with ventilator fan only < 0.5 K with 5 W heater < 1 K with 10 W heater
Offset caused by 10 W heater	< 1 W/m ² for CMP 11 Pyranometer
Tacho output	5 V, 2 pulses per revolution
Power required	12 Volt DC, 1.3 A (with 10 W heater)
Cable voltage drop	0.07 V/m (with 10 W heater)
Weight (excluding cable)	1,6 kg
CVF 3 has a standard cable length of 10 m. Optional cable lengths 25 m and 50 m.	
Accessory CVP 2 universal AC-DC power supply for 1 or 2 x CVF 3 (with 10W heating).	
Accessory Powerbox weatherproof heavy duty AC-DC power supply for 1, 2 or 3 x CVF 3 (with 10W heating).	
Spare ventilator fan inlet filters are available in packs of 5 filters.	

Note: CVP 2 is not suitable for unprotected outdoor use.

Building a system

CVF 3 is designed to be used with Kipp & Zonen CMP 6, 11, 21 and 22 pyranometers, the CGR 4 pyrgeometer, and the CUV 4 total UV radiometer.

The instrument bubble level is visible through the ventilator air outlet in the cover, which is easily removed to check the radiometer desiccant. CVF 3 is backwards compatible with the older CM and CG series radiometers and uses the same mountings as the CV 2.

CVF 3 can be mounted on the 2AP and SOLYS 2 sun trackers and the CM 121C shadow ring. The ventilation fan and heaters run from 12 VDC. The accessory CVP 2 universal AC-DC power supply can operate up to two CVF 3 ventilation units with the heaters on.

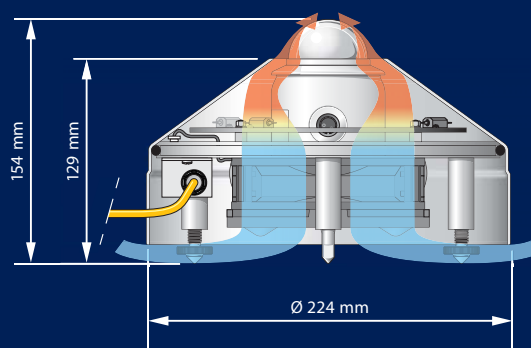

Go to www.kippzonen.com for your local distributor

HEAD OFFICE

Kipp & Zonen B.V.
 Delftechpark 36, 2628 XH Delft
 P.O. Box 507, 2600 AM Delft
 The Netherlands
 T: +31 (0) 15 2755 210
 F: +31 (0) 15 2620 351
 info@kippzonen.com

Kipp & Zonen B.V. reserve the right to alter specifications of the equipment described in this documentation without prior notice



4414392-0901