

CSAT3

3-D Sonic Anemometer

Campbell Scientific's CSAT3 3-D Sonic Anemometer has a 10 cm vertical measurement path, operates in a pulsed acoustic mode, and withstands exposure to harsh weather conditions. Three orthogonal wind components (u_x , u_y , u_z) and the speed of sound (c) are measured and output at a maximum rate of 60 Hz. Analog outputs and two types of digital outputs are provided.

Measurements can be triggered from three sources:

- CSAT3's internal clock,
- PC-generated RS-232 command
- Datalogger's SDM command

The SDM protocol supports a group trigger for synchronizing multiple CSAT3s. The FW05 fine wire thermocouple (12.7 μm diameter) is available as an option for fast response temperature measurements.



The CSAT3, shown making measurements over a fallow field in Minnesota, provides precision turbulence measurements with minimal flow distortion.

Specifications

Measurements

Outputs:	u_x , u_y , u_z , c (u_x , u_y , u_z are wind components referenced to the anemometer axes; c is speed of sound)
Speed of Sound:	Determined from three acoustic paths; corrected for cross-wind effects
Measurement Rate:	programmable from 1 to 60 Hz, instantaneous measurements; two over-sampled modes are block averaged to either 20 Hz or 10 Hz
Measurement Resolution:	u_x , u_y is 1 mm s^{-1} rms; u_z is 0.5 mm s^{-1} rms; c is 15 mm s^{-1} (0.025°C) rms; values are for instantaneous measurements made on a constant signal; noise is not affected by sample rate
Accuracy*	
Offset error:	< ± 8.0 cm s^{-1} (u_x , u_y) < ± 4.0 cm s^{-1} (u_z)
Gain error:	< $\pm 2\%$ of reading (wind vector within $\pm 5^\circ$ of horizontal) < $\pm 3\%$ of reading (wind vector within $\pm 10^\circ$ of horizontal) < $\pm 6\%$ of reading (wind vector within $\pm 20^\circ$ of horizontal)
Rain:	Innovative ultrasonic signal processing and user-installable wicks considerably improve the performance of the anemometer under all rain events

Output Signals

Digital SDM:	CSI 33.3 k baud serial interface for datalogger/sensor communication. Data type is 2-byte integer per output plus 2-byte diagnostic
Digital RS-232	
Baud rate:	9600, 19200 bps
Data type:	2-byte integer per output plus 2-byte diagnostic
Analog	
Number of outputs:	4
Voltage range:	$\pm 5\text{V}$
Number of bits:	12

Reporting Range

SDM and RS-232 Digital Outputs

Full scale wind:	± 65.535 m s^{-1} autoranging between four ranges; least significant bit is 0.25 to 2 mm s^{-1}
Speed of sound:	300 to 366 m s^{-1} (-50° to $+60^\circ\text{C}$); least significant bit is 1 mm s^{-1} (0.002°C)

Analog Outputs:

Output	Range	LSB
u_x , u_y	± 30 m s^{-1} , ± 60 m s^{-1}	15 mm s^{-1} , 30 mm s^{-1}
u_z	± 8 m s^{-1}	4 mm s^{-1}
c	300 to 366 m s^{-1} (-50° to $+60^\circ\text{C}$)	16 mm s^{-1} (0.026°C)

*Accuracy specifications assume -30° to $+50^\circ\text{C}$ operating range; wind speeds < 30 m s^{-1} ; wind angles between $\pm 170^\circ$.

Specifications Continued

Physical Description

Measurement Path Length: 10.0 cm vertical; 5.8 cm horizontal

Path Angle from Horizontal: 60 degrees

Transducer: 0.64 cm diameter

Transducer Mounting Arms: 0.84 cm diameter

Support Arms: 1.59 cm diameter

Dimensions

Anemometer head: 47.3 cm (l) x 42.4 cm (h)

Electronics box: 26 cm x 16 cm x 9 cm

Weight

Anemometer head: 1.7 kg (3.7 lb)

Electronics box: 3.8 kg (8.4 lb)

Construction:

Sealed sonic transducers and electronics.

Materials

Anemometer head: stainless steel tubing

Electronics box: cast aluminum

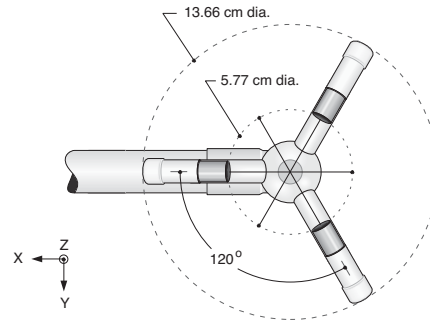

Lower Transducer Assembly Top View

Environmental

Operating Temperature Range:

-30° to +50°C

Power Requirements

Voltage Supply:

10 to 16 Vdc

Current:

200 mA @ 60 Hz measurement rate; 100 mA @ 20 Hz measurement rate

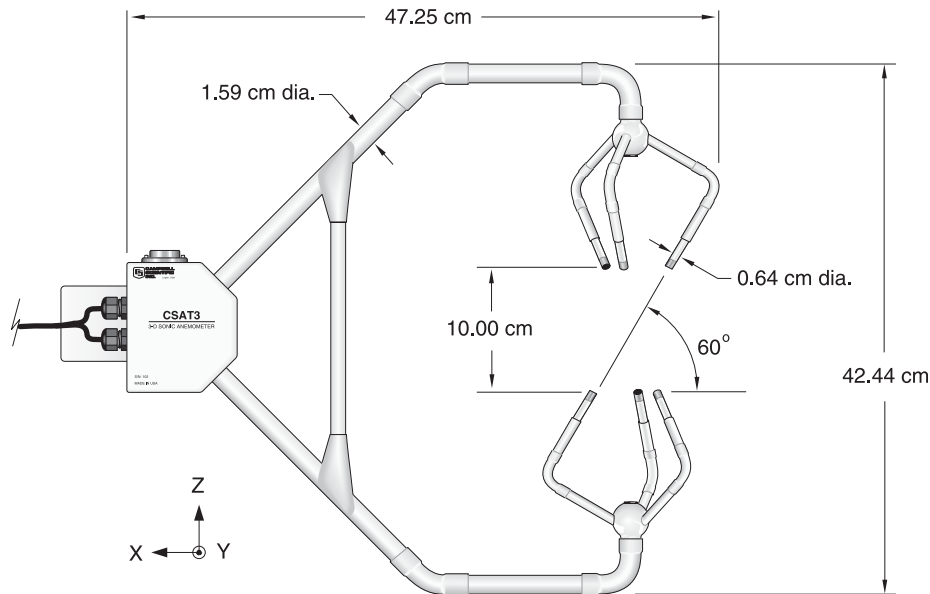

Anemometer Head

