

INSTRUCTION MANUAL

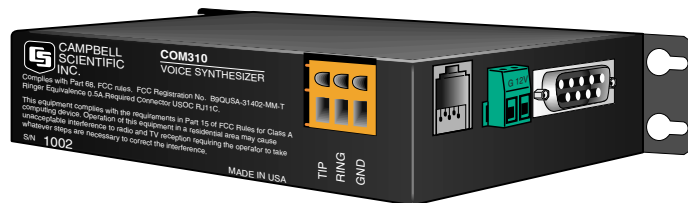

COM310 Voice Communications Modem

Revision: 11/11



Copyright © 2002-2011
Campbell Scientific, Inc.

WARRANTY AND ASSISTANCE

This equipment is warranted by CAMPBELL SCIENTIFIC (CANADA) CORP. ("CSC") to be free from defects in materials and workmanship under normal use and service for **twelve (12) months** from date of shipment unless specified otherwise. ***** **Batteries are not warranted.** ***** CSC's obligation under this warranty is limited to repairing or replacing (at CSC's option) defective products. The customer shall assume all costs of removing, reinstalling, and shipping defective products to CSC. CSC will return such products by surface carrier prepaid. This warranty shall not apply to any CSC products which have been subjected to modification, misuse, neglect, accidents of nature, or shipping damage. This warranty is in lieu of all other warranties, expressed or implied, including warranties of merchantability or fitness for a particular purpose. CSC is not liable for special, indirect, incidental, or consequential damages.

Products may not be returned without prior authorization. To obtain a Return Merchandise Authorization (RMA), contact CAMPBELL SCIENTIFIC (CANADA) CORP., at (780) 454-2505. An RMA number will be issued in order to facilitate Repair Personnel in identifying an instrument upon arrival. Please write this number clearly on the outside of the shipping container. Include description of symptoms and all pertinent details.

CAMPBELL SCIENTIFIC (CANADA) CORP. does not accept collect calls.

Non-warranty products returned for repair should be accompanied by a purchase order to cover repair costs.



CAMPBELL SCIENTIFIC
C A N A D A C O R P .

11564 - 149 street - edmonton - alberta - T5M 1W7
tel 780.454.2505 fax 780.454.2655

www.campbellsci.ca

PLEASE READ FIRST

About this manual

Please note that this manual was originally produced by Campbell Scientific Inc. (CSI) primarily for the US market. Some spellings, weights and measures may reflect this origin.

Some useful conversion factors:

Area: 1 in² (square inch) = 645 mm²

Length: 1 in. (inch) = 25.4 mm
1 ft (foot) = 304.8 mm
1 yard = 0.914 m
1 mile = 1.609 km

Mass: 1 oz. (ounce) = 28.35 g
1 lb (pound weight) = 0.454 kg

Pressure: 1 psi (lb/in²) = 68.95 mb

Volume: 1 US gallon = 3.785 litres

In addition, part ordering numbers may vary. For example, the CABLE5CBL is a CSI part number and known as a FIN5COND at Campbell Scientific Canada (CSC). CSC Technical Support will be pleased to assist with any questions.

COM310 Table of Contents

PDF viewers: These page numbers refer to the printed version of this document. Use the PDF reader bookmarks tab for links to specific sections.

1. Introduction	1
2. Specifications	2
3. Quick Start	2
4. System Components	11
4.1 COM310 Modem.....	11
4.2 Surge Suppressor	12
4.3 Voice Capable Dataloggers	12
4.3.1 Mixed-array	12
4.3.2 Table Data.....	12
4.3.3 PakBus	12
4.4 Telephone	12
5. Datalogger Voice Programming	13
5.1 Features.....	13
5.1.1 Callback	13
5.1.2 Voice Callin	14
5.1.3 Voice Storage Data	14
5.2 Native PakBus Dataloggers	15
5.2.1 Voice Instructions	15
5.2.2 Data Callback.....	17
5.3 Edlog Dataloggers and LoggerTalk.....	19
5.3.1 Install	19
5.3.2 Helps and Tutorials.....	19
5.3.3 Modem Security Code	20
5.3.4 Commercial Mode.....	20
5.3.5 Custom Menu Strings	20
5.3.6 Voice Callback.....	21
5.3.7 View and Remove Voice Code.....	21
5.4 LoggerNet.....	21
6. Hardware Installation	22
6.1 Site Requirements.....	22
6.2 Powering the COM310 Modem.....	23
6.3 Grounding the COM310 System	24
6.4 Telephone Service	25
6.5 Telephone Transfers	25
6.6 Connecting to a Surge Protector	25

7. Troubleshooting COM310 Voice Systems27
 7.1 No Communications 27
 7.2 Communications Problems 28

Appendices

A. Theory of Operation A-1

**B. FCC Warning to Users of Class A Computing
 Devices B-1**

C. IC Information C-1

D. Set Rings, AT Parameters D-1
 D.1 Set Number of COM310 Rings before Answer D-1
 D.2 Telephone Connection to COM310 D-1

E. CS I/O 9 Pin Serial Port E-1

F. Reading Voice Code in a *.DLD File F-1
 F.1 Typical Voice Code F-1
 F.2 Callback Code..... F-2
 F.3 Modem Security Enabled..... F-3

G. COM310 Word List G-1
 G.1 COM310 Word List – Numerical Order G-1
 G.2 COM310 Word List – Alphabetical Order..... G-3

Figures

1. COM310 Voice Synthesizer Modem..... 1
 2. COM310 Hardware Connection Using Standard RJ11 Phone Jack 22
 3. COM310/CR1000 Using Surge Protection Device..... 23
 4. COM310 Grounding and Alternate 12 VDC Power 24
 5. Top View of Surge Suppressor Wiring..... 26
 6. Side View of Surge Suppressor Wiring 27
 E-1. COM310’s Male 9 Pin Connector.....E-1

COM310 Voice Communications Modem

1. Introduction

The COM310 is a voice-synthesizer modem that supports the PakBus and mixed-array dataloggers that have voice capability (see Section 4.3). The COM310 allows them to announce by telephone the data stored in variables or input locations, the status of control ports, and the status of user flags. Included is the ability to toggle datalogger ports and flags. You can program a datalogger so you can call-in to the station and listen to announcements, or so the datalogger calls you with an announcement when specified conditions are met, or you can program for both.

Although the primary function of the COM310 is voice communications, the modem is also capable of *data* communications. In data mode the COM310 supports standard datalogger functions including program send and data collection. The COM310 supports data callback from the CR1000, CR3000, and other dataloggers with OSs that support it. The CR10X, CR510, and CR23X mixed-array OSs support data callback but their PakBus OSs do not.

This manual provides information regarding COM310 specifications, installation, and operation. Quick Start (Section 3) presents an example CR1000 voice callback/callin program with descriptions of the code.

⚡ Section 6.3 explains how to make a good earth ground connection to maximize protection of the COM310 against lightning and electro-static discharge.

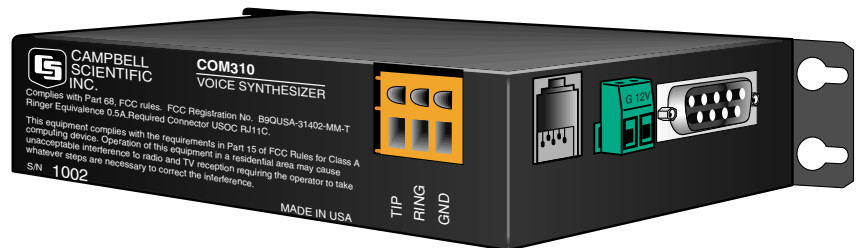

FIGURE 1. COM310 Voice Synthesizer Modem

2. Specifications

- Bell 212A, CCITT V.21, and V.32BIS compatible
- Full duplex at 9600 and 1200 baud to datalogger
- V.42 LAPM and MNP2-4 error detection/correction
- Hayes AT command set
- RJ-11C telephone jack
- FCC and IC (formerly known as DOC) approval
- Pulse or tone dialing
- Power supply voltage requirement: 12 VDC
- Power supply current drain: 100 μ A quiescent, 180 mA active
- Internally switches 12 VDC power to minimize current drain
- Connects directly to CS I/O port of many CSI dataloggers (for communications and 12V power)
- Logic levels: below 1.5 V inputs a low state and above 3.5 V inputs a high state. A low voltage level on the TX data input (pin 9) and RX data output (pin 4) represents a mark
- Operational temperature: -25°C to $+50^{\circ}\text{C}$
- Size: 5.2" x 1.7" x 3.6" // 13.1 x 4.3 x 9.2 cm
- Weight: 0.75 lbs // 0.34 kg

For information regarding the COM310 theory of operation refer to Appendix A of this manual.

3. Quick Start



This section presents Basic_Voice_2.crl an example voice callback/callin program written to demonstrate functions of the COM310. It can serve as a starting point from which you build your own application program. Test well the auto-disconnect capability as you customize the voice code and merge your measurement sections with the voice code.

To demo the example program, obtain the following items or their equivalent:

- 1) COM310 (OS01062006.SR or later OS)
- 2) SC12 Cable
- 3) CR1000 datalogger
- 4) 3 inches of thermocouple wire
- 5) PS100 Power Supply
- 6) Phone modem for your PC
- 7) LED in series with 1000 Ohm resistor
- 8) Analog phone line

NOTE

Some office phone lines are digital and the COM310 cannot interface to them. Connect the COM310 to analog phone lines only.

You will also need:

- 1) IBMTM compatible PC with available COM port
- 2) LoggerNet 3.15 or later installed on PC.

Unlike the CR10X, CR510 and CR23X where voice code is appended to a finished measurement program using LoggerTalk software, the CR1000 voice code is created along with the measurement program using the CRBasic editor. It is recommended you finish and debug the voice portion of your program first, and then add the measurement code.

The example CR1000 voice callback/callin program that follows supports the following functions:

- Voice callin
- Voice callback
- Auto-disconnect
- Auto redial
- Alarm reset

The following steps show how to build a station to demo the example voice callback/callin program. The voice station can further serve to test/debug your custom voice program and merge it with your application program.

Step 1 – LoggerNet Setup

- 1) In LoggerNet Setup create the following device map



- 2) Configure ComPort and PhoneBase for your PC's phone modem.
- 3) Configure PhoneRemote to include the COM310's analog phone number followed by six commas and a 9.
- 4) Click on CR1000phone (renamed) and verify that the PakBus Address is 1.

Step 2 – Hardware Setup

- 1) Start with a CR1000 having factory settings. If unsure of settings, close LoggerNet, connect SC12 cable from PC ComPort to CR1000 RS-232 port, run Device Configuration Utility, set Serial Port to match the PC ComPort, Connect and click on the Factory Defaults button, Apply settings and Disconnect.
- 2) Connect CR1000 to PS100 (turned off).
- 3) Connect SC12 cable from COM310 to CR1000 CS I/O port.
- 4) Connect analog phone line to COM310.
- 5) Turn on PS100.
- 6) Connect prepared TC to CR1000's DIFF 7 analog input.
- 7) Connect LED with 1000 Ohm resistor connected to anode lead from C1 to G (resistor to C1).

Step 3 – Send BASIC_VOICE_2.CR1 to CR1000

- 1) Download BASIC_VOICE_2.CR1 from CSI web site under Support, Downloads, Program Examples to a folder on your hard drive.
- 2) From LoggerNet Toolbar run CRBasic editor and open BASIC_VOICE_2.CR1.
- 3) Change PHONE1 (a constant in SlowSequence near bottom of program) to your office phone number to be used for callback and Save and Compile the change.
- 4) You can change PHONE2, etc. to nearby phone numbers for testing or comment out those lines of code. NUMPHONES should equal the number of active phone numbers.
- 5) If the TC at DIFF 7 isn't Type T, change the program to match your TC type and Compile and Save.
- 6) Connect to CR1000phone and in Connect Screen, Tools, File Control send VOICE.TXT (typically in C:\Campbellsci\Lib\Compilers) to the CR1000.
- 7) ConnectScreen send BASIC_VOICE_2.CR1 to CR1000phone.

NOTE

If you send BASIC_VOICE_2.CR1 before VOICE.TXT, you'll see some errors. In this case just send VOICE.TXT followed by BASIC_VOICE_2.CR1 again, and it will compile properly.

- 8) Close File Control and Disconnect from CR1000phone
- 9) Your CR1000 voice station is ready to demo

Step 4 – Callin

- 1) Using a touch-tone phone, dial the number of the analog phone line connected to the COM310.
- 2) You should hear a ring or two, some faint clicking and then the voice announcements:

CURRENT STATION DATA
PRESS ONE TO HEAR THE BATTERY VOLTAGE
PRESS TWO TO HEAR THE DATALOGGER TEMPERATURE
PRESS THREE TO HEAR THE T C TEMPERATURE
PRESS STAR TO DISCONNECT

- 3) Pressing 1, 2, 3, or * should produce the result indicated.

Step 5 – Callback

- 1) Grip the end of the thermocouple to raise its temperature above 85F setting an alarm condition.
- 2) In a few seconds you should be able to detect the dial tones as a voice callback proceeds. The first phone number in the program should ring. Picking up the phone you should hear:

PRESS POUND TO RESET ALARM, PRESS STAR TO DISCONNECT

Pressing the # key you should hear:

C R ONE THOUSAND STATION
PRESS ONE TO HEAR A SENSOR VALUE
PRESS TWO TO HEAR OR TOGGLE PORT
PRESS THREE TO HEAR OR TOGGLE FLAG
PRESS STAR TO DISCONNECT

- 3) Navigate around in the menus to learn the program's capabilities:
 - a) Press 2 to access the Ports Menu
 - b) Press 1 to read the logic state of Control Port 1
 - c) Press # to toggle the logic state of Control Port 1 (C1's LED should turn on).
 - d) Press # again (C1's LED should turn off)
 - e) Press * to return to "C R ONE THOUSAND STATION" menu
 - f) Press * to hang up
- 4) Try hanging up the phone without pressing * (disorderly exit) and see if the modem automatically hangs up after a few seconds.
- 5) As you press the keys to navigate around in the menus you will find that occasionally you get an unexpected response. Phone connections are susceptible to noise pickup and signal attenuation. Depending on your particular phone equipment and the phone lines and equipment between you and the voice station, you may at times experience some of the following:
 - a) You press * and the voice station hangs up but doesn't say, "Goodbye."
 - b) A voice callback rings your phone but you pick up to silence

Certain phones are more of a problem due to low signal levels or switch bounce.
- 6) Helpful hints for pressing phone keys to control a voice station
 - a) Press a key firmly (but not too long)
 - b) Allow a second between keys
 - c) Press the same key again if a wrong response is gotten
 - d) If no response, try pressing key again or press # key to recover
 - e) If unresponsive, try rapidly pressing a series of five * keys to disconnect station.
 - f) Worst case, allow 6 minutes for the voice station to reset itself

Following is the text of the BASIC_VOICE_2.CR1 example voice callback/callin program employing VoiceSetup(). The program should be available for download on our website under Support/Downloads/Program Examples. Following the program is a description of its main sections.

```

' CR1000

' BASIC_VOICE_2.CRI

' Send VOICE.TXT to CR1000 before sending this program.

' Program employs VoiceSetup instruction available in OS CR1000.Std.12 and later

' 1st phone number is called if Diff 7 TC temperature > 85F
' Program continues to call callback phone number list until someone answers and presses # key
' resetting alarm.
' Callback phone numbers are in constants in the SlowSequence at the bottom of the program.

' Key Press Functions:
' # resets alarm condition or toggles port/flag
' 1,2,3,4,5,6,7,8 select certain menu items
' * returns one menu level (returns from subroutine) or disconnects
' 0 is not used in this program
' 9 should be avoided since it will trigger an attempt to connect to a modem

' Timeouts (for key presses and for the total on line time) are constants listed below
' and can be adjusted.

Public Value(3)
Alias Value(1) = BatteryV
Alias Value(2) = PTemp
Alias Value(3) = TCValue_F

Const KeyTimeout = 800           ' 8 second timeout waiting for key stroke before hangup
Const SecsOnLine = 360          ' 6 minutes On Line Timeout
Const STAR = 42                 ' The * key (STAR)
Const POUND = 35                ' The # key
Const HangupIfKeyTimeout = TRUE ' Will hangup if times out waiting for a key
Const RINGTIME = 20             ' Maximum time allowed for a phone to be picked up and #pressed

Public mykey As Long

' **** VOICE CODE executed when DL detects COM310 RING or when DialVoice() succeeds ****

Public CallingOut As Boolean    ' Detects whether we are calling out or calling in

' STAR (*) key will be used to return from subroutines and to disconnect if not in a subroutine

VoiceSetup (STAR,STAR,0,SecsOnLine,HangupIfKeyTimeout,CallingOut)

VoiceBeg
  If CallingOut Then           ' We are calling out triggered by DialVoice()
    Call CallOutVoice
  Else
    Call CallInVoice           ' We are calling in
  EndIf
EndVoice

```

```

' ***** Subroutines *****

' Called when calling in:
Sub CallInVoice
  Do
    VoiceSpeak ("CURRENT STATION DATA 50MS 50MS", 0)
    VoiceSpeak ("PRESS ONE TO HEAR THE BATTERY VOLTAGE 50MS", 0)
    VoiceSpeak ("PRESS TWO TO HEAR THE DATALOGGER TEMPERATURE 50MS", 0)
    VoiceSpeak ("PRESS THREE TO HEAR THE T C TEMPERATURE 50MS", 0)
    VoiceSpeak ("PRESS STAR TO DISCONNECT", 0)
    Select Case VoiceKey(keytimeout)
    Case 1
      VoiceSpeak ("THE BATTERY VOLTAGE IS" + Value(1) + "VOLTS", 1)
    Case 2
      VoiceSpeak ("THE REFERENCE IS" + Value(2) + "DEGREES", 1)
    Case 3
      VoiceSpeak ("THE AIR TEMPERATURE IS" + Value(3) + "DEGREES", 0)
    EndSelect
  Loop ' Until timeout or STAR
EndSub

' Called when calling out:
Public Alarm As Boolean, ArmAlarm As Boolean, ManualAlarm As Boolean

Sub CallOutVoice
  ' Dial # reset to reset alarm = 0
  Timer(1,Sec,2) ' Start timer
  Do
    VoiceSpeak("50MS PRESS POUND TO RESET ALARM 50MS PRESS STAR TO DISCONNECT", 0)
    mykey = VoiceKey(0)
    If Timer(1,Sec,4) >= RINGTIME Then ExitSub ' Max time to await pick up and # press
  Loop Until mykey = POUND
  ' Someone cleared the alarm, let them proceed and do other things
  Alarm = False
  Do ' Until timeout
    VoiceSpeak ("50MS C R ONE THOUSAND STATION 50MS 50MS", 0)
    VoiceSpeak ("PRESS ONE TO HEAR A SENSOR VALUE 50MS 50MS", 0)
    VoiceSpeak ("PRESS TWO TO HEAR OR TOGGLE PORT 50MS 50MS", 0)
    VoiceSpeak ("PRESS STAR TO DISCONNECT 50MS 50MS", 0)
    Select Case VoiceKey(KeyTimeout)
    Case 1
      Call SubKey1
    Case 2
      Call SubKey2
    Case 3
      Call SubKey3
    EndSelect
  Loop ' Until timeout
EndSub

```

```

' Monitors a value
Sub SubKey1
  Do
    VoiceSpeak ("50MS PRESS SENSOR NUMBER 50MS PRESS STAR TO RETURN", 0)
    mykey = VoiceKey (KeyTimeout)
    If mykey = 1 Then VoiceSpeak ("50MS THE BATTERY VOLTAGE IS" + Value(1) + "VOLTS", 1)
    If (mykey = 2) Then VoiceSpeak ("50MS THE REFERENCE IS" + Value(2) + "DEGREES", 1)
    If (mykey = 3) Then VoiceSpeak ("50MS THE T C IS" + Value(3) + "DEGREES", 1)
  Loop
  ' Sensor value loop
EndSub

' Read a port and possibly toggle
Sub SubKey2
  Do ' Until * or timeout
    Dim keybit,port As Long,state
    VoiceSpeak("50MS PRESS PORT NUMBER 50MS PRESS STAR TO RETURN", 0)
    port = VoiceKey(keyTimeout)
    If (port > 0) AND (port <= 8) Then
      keybit = 2^(port-1) ' Bit 0..7 is set in keybit. Keybit = 2^(port-1).
      Do
        ReadIO(state, &b11111111)
        VoiceSpeak("50MS C" + port + "IS",0)
        If state AND keybit Then
          VoiceSpeak("ON",0)
        Else
          VoiceSpeak("OFF",0)
        EndIf
        VoiceSpeak("50MS PRESS POUND TO TOGGLE 50MS PRESS STAR TO RETURN", 0)
        If VoiceKey(KeyTimeout) = POUND Then
          ReadIO (state,&b11111111)
          If state AND keybit Then
            state = state AND (NOT keybit)
          Else
            state = state OR keybit
          EndIf
          WriteIO(&b11111111,state) ' Toggle control port
        EndIf
      Loop
    EndIf
  Loop
EndSub

' Read a flag and possibly toggle
Sub SubKey3
  Const NUMBERFLAGS = 8
  Public Flags(NUMBERFLAGS)
  Do ' Until * or timeout
    VoiceSpeak("50MS PRESS FLAG NUMBER 50MS PRESS STAR TO RETURN", 0)
    mykey = VoiceKey(keyTimeout)
    If (mykey > 0) AND (mykey <= NUMBERFLAGS) Then
      Do
        VoiceSpeak("50MS FLAG" + mykey + "IS",0)
      Loop
    EndIf
  Loop
EndSub

```



```

ElseIf (TCvalue_F > 85 AND ArmAlarm) OR ManualAlarm = TRUE Then
  ManualAlarm = False
  Alarm = TRUE'
  Do
    For i = 1 To NUMPHONES
      ' Call these numbers until the alarm is cleared
      If Alarm Then DialVoice(phones(i)) ' Calls only if alarm is set
    Next i
    If Alarm Then Delay(1,1,min)
  Loop Until Alarm = FALSE
  ArmAlarm = False
EndIf
Loop
EndProg

```

Example Program Description

Basic_Voice_2.cr1 has five main sections:

1. VoiceSetup() - handles auto-disconnect.
2. Voice Beg / EndVoice - routes execution to callin or callout subroutines.
3. CallInVoice Subroutine - executes when VoiceBeg detects a callin
4. CallOutVoice Subroutine - executes when VoiceBeg detects a dial-up. It looks for a pound (#) key to reset “alarm” variable to false.
5. SlowSequence - continually looks for the “alarm” variable to be true which, if it finds, it dials a list of phone numbers until “alarm” is no longer true. It signals Voice Beg when a callout dial-up is in progress.

VoiceSetup()

The VoiceSetup instruction is used to control the hang up of the COM310 voice modem. It controls which key is used to exit a subroutine and which is used to continue to the next VoiceKey instruction. It also determines how long the COM310 can be ‘off hook’ before the datalogger automatically hangs it up (auto-disconnect). And it controls whether or not the modem hangs up after a VoiceKey instruction timeout. The “Callout” parameter indicates that the modem has received a ‘call in’ or has dialed a ‘call out.’

WARNING

The VoiceSetup SecsOnLine setting is important as it hangs up (auto-disconnects) the modem in case someone cradles the phone or leaves the phone off-hook without pressing star keys for an orderly “good-bye” disconnect. Test well your entire program in this regard before deployment to avoid possible lengthy off-hook states disallowing incoming calls, running up a phone bill and draining the station power supply.

Voice Beg / EndVoice

The VoiceBeg / EndVoice instruction pair enclose the code that is executed when the datalogger detects a ring from its voice modem (at call in).

CallInVoice Subroutine

This subroutine contains the code pointed to by VoiceBeg / EndVoice that is to execute after a call in occurs. It consists mainly of VoiceSpeak menu announcements followed by a VoiceKey instruction prompting caller input and a Select Case statement choosing the program's responses to various caller key presses.

CallOutVoice Subroutine

The CallOutVoice subroutine contains the code that is to execute when VoiceBeg / EndVoice detects that a call out phone number has been dialed. It prompts a responding party to press the # key after which it announces the menu selections to hear: battery voltage, panel temperature, or thermocouple temperature (SubKey1); datalogger port status of C1 - C8 (SubKey2); or datalogger flag status of F(1) - F(8) (SubKey3). The state of the ports and flags can be toggled as well as heard.

SlowSequence

Contains code that continually executes looking for the Diff 7 thermocouple to exceed 85F in which case the variable "alarm" is set to True and a call out (callback) is initiated. It dials the first phone number on the list. If no answer, after 20 seconds the second number is dialed. The list of phone numbers is dialed repeatedly until someone picks up and presses the # key (monitored by the CallOutVoice subroutine) which resets "alarm" to False and allows the responding party to proceed into the CallOutVoice menus.

4. System Components

4.1 COM310 Modem

Connecting a COM310 voice modem to a datalogger provides all COM210 supported functions plus the following:

- Voice retrieval of data (user or datalogger initiated)
- Reading/Toggling of datalogger control ports
- Reading/Toggling of program Flags

The COM310 ships with an SC12 cable (9-pin to 9-pin) for connecting between the modem CS I/O port and datalogger CS I/O port.

NOTE

The COM310's communication port is designed to function with a Campbell Scientific CS I/O port. This is not an RS-232 port. See Appendix E for the CS I/O port description.

4.2 Surge Suppressor

If the phone company does not provide surge protection at the datalogger site, you will need to install some. CSI offers surge protectors in two forms. Item # 6362 is a surge protector with environmental enclosure mounting hardware. Item # 4330 is the surge protector with no mounting hardware (see Section 6.6).

4.3 Voice Capable Dataloggers

There are several Campbell Scientific dataloggers that are capable of voice communications. The following sections tell which mixed-array, PakBus, and table-based dataloggers are capable of which functions.

4.3.1 Mixed-array

A CR10X, CR510, or CR23X with mixed-array OS is capable of COM310 voice communications.

4.3.2 Table Data

The TD OSs (OS10XTD, OS510TD, and OS23XTD) do not support any COM310 communications. For data collection you can use a COM210 modem.

4.3.3 PakBus

With PakBus dataloggers the COM310 supports such functions as program send, data collection, and clock check. The following voice/data functions are supported as well.

COM310/PakBus Datalogger Support			
DATALOGGER	Voice Callback	Voice Callin	Data Callback
CR1000	yes	yes	yes
CR10XPB	yes	yes	no
CR510PB	yes	yes	no
CR23XPB	yes	yes	no

The COM310 supports concurrent communications. PakBus dataloggers with multiple peripherals (COM310, RF450, RF401, MD485, NL100, CR10KD, CR1000KD, and SC32B) can communicate simultaneously via those peripherals.

4.4 Telephone

A touch-tone phone is normally used to call the COM310 modem. A rotary phone will work if the programmed voice announcements do not require you to navigate through the COM310's menu system.

NOTE The COM310 must connect to an analog phone line. Some office environment PBX phone lines are digital and don't interface to an analog modem such as the COM310. Of course, any phone may be used to call in to or receive callbacks from the COM310. A touch-tone phone is necessary for input.

5. Datalogger Voice Programming

The voice code for the CR1000 and other voice capable CRBasic dataloggers is integrated with the main program. It is probably advantageous to write your custom voice program and debug it before adding the measurement part. The example voice callback/callin program in Quick Start can provide a starting point for your program.

With the CR10X, CR510, and CR23X dataloggers, voice code is added to Edlog created dld files using LoggerTalk software.

5.1 Features

The voice instructions listed in 5.2.1 are combined with standard CRBasic instructions to create the code needed for telephone answering, dialing, voicing word strings, voicing data, receiving key presses from the remote phone, and acting upon those key presses.

For Edlog dataloggers, use multiple P97s with a different flag for each P97.

5.1.1 Callback

Callback is the ability of a datalogger/COM310 station to initiate a phone call 'back' to a PC running LoggerNet (data mode) or to a telephone (voice mode). You can include data callback and voice callback code in the same program. See example CR1000 voice callback/callin program for details.

5.1.1.1 Data Callback

A station can be programmed to do a data callback in the event specified conditions are met to a PC (with phone modem) running LoggerNet. Data callback causes LoggerNet to collect datalogger data marked for collection. You must enable Callback (sometimes in two places) in LoggerNet Setup.

A CR1000 program uses a SendVariables instruction to effect a data callback (see example data callback program below). No callback ID is used.

A CR10X, CR510 or CR23X program uses a P97 typically with a "42" in Parameter 1 for 9600 baud. A callback ID is required in P97's Parameter 8 matching that assigned in the LoggerNet Setup.

Data callback is not supported in table-based or PakBus OSs for the CR10X, CR510, and CR23X.

5.1.1.2 Voice Callback

The COM310 gives you the ability to do *voice* callbacks. You can program a station to call one or more telephone numbers and announce an alarm message when conditions you specify are met. You can input multiple phone numbers to increase the probability that someone will receive the message.

CRBasic dataloggers accomplish voice callback with a combination of VoiceSetup, VoiceKey, VoiceSpeak, and DialVoice instructions (see example voice callback/callin program).

Mixed-array datalogger programs require a P97 with a “31” in Parameter 1. PakBus dataloggers have a P97 in the program with a “39” in Parameter 1. LoggerTalk is used to create and append voice code to a completed Edlog program. No callback ID is used in either case.

For more information on Edlog datalogger voice callback refer to LoggerTalk Help’s Callback Tutorial. Also, the datalogger operator’s manual includes general information regarding voice callback.

Example P97 for mixed-array datalogger voice callback:

18:	Initiate Telecommunications (P97)	
1:	31	VS1-Com300/310 Voice
2:	5	Disabled when User Flag 5 is High
3:	45	Seconds Call Time Limit
4:	30	Seconds Before Fast Attempts
5:	1	Fast Attempts
6:	30	Minutes Before Slow Attempts
7:	2	Failure Loc [P97_Failures]
8:	0000	Call-Back ID

5.1.2 Voice Callin

Callin is the ability of a station to accept a phone call and announce words and data and, possibly, accept menu key presses. All voice capable dataloggers support callin. Voice capable CRBasic dataloggers require that callin code be added to the program (see example voice callback/callin program in Quick Start). Voice capable Edlog datalogger programs require LoggerTalk to append code to the *.dld file for callin (see LoggerTalk Help).

5.1.3 Voice Storage Data

The COM310 can only voice *variable* or *input location* data. But with voice capable Edlog dataloggers you can voice final storage data by redirecting the desired final storage data to input locations. Datalogger Instruction P80 is used for that. For more information on the P80 instruction refer to the datalogger operator’s manual.

For voice capable CRBasic dataloggers, you can voice table data by setting a variable equal to Tablename.Fieldname (fieldname index, records back) to get a specific field from a data table (for more information see CR1000 section Program Access to Data Tables).

The VoiceSpeak code might look like this:

```
TC_1 = Public.AirTemp(1,1)
```

```
VoiceSpeak ("THE AIR TEMPERATURE WAS" + TC_1 + "DEGREES", 0)
```

5.2 Native PakBus Dataloggers

The CR1000 and other voice capable CRBasic dataloggers can be programmed to provide the features available in the Edlog dataloggers, and most any other feature you can imagine. The Quick Start example voice callback/callin program "BASIC_VOICE_2.CR1" provides a starting point from which to build the features you want.

5.2.1 Voice Instructions

Patterned after the example program in Quick Start, voice instructions can be combined in a variety of ways to provide phone access to datalogger data and for control of datalogger flags/output ports.

5.2.1.1 VoiceBeg / EndVoice

This instruction pair contains the code executed when the CR1000 detects a RING signal from the COM310 (a call in). It is placed in the declarations portion of the program before the BeginProg instruction. The EndVoice instruction hangs up the modem. So, VoiceHangup is not required unless you want to hang up the modem under certain condition(s) prior to the execution of the EndVoice instruction.

The VoiceKey instruction is also used to add a delay before the EndVoice instruction is executed so that the datalogger will not end the VoiceSpeak command before the spoken message is completed.

5.2.1.2 VoiceSpeak

The VoiceSpeak instruction is used to define the voice string that should be spoken by the voice modem. The spoken string is comprised of words from the Voice.txt file and variables. The words are enclosed with quotes, and any variables are concatenated with the words using a plus sign (e.g., "50MS THE BATTERY VOLTAGE IS" + Value(1) + "VOLTS"). The word "50MS" inserts a 50 millisecond pause during the announcement. It can be inserted multiple times in series if desired.

5.2.1.3 VoiceKey

The VoiceKey instruction is used to add a delay before the EndVoice instruction is executed so that the datalogger does not end the VoiceSpeak command before the announcement is finished.

The VoiceKey instruction's timeout parameter is used to add a delay (in 0.01 seconds) before EndVoice or Loop is executed. Multiple VoiceKey instructions placed before an EndVoice or Loop instruction increase the delay. The VoiceKey timeout provides silent time for a user to respond to the

announced menu; however, the user can respond by pressing a key in the middle of an announcement.

If doing concurrent communications (via multiple communication peripherals) with your datalogger it is recommended that the VoiceKey timeout be extended to over 5 seconds.

VoiceSetup's UseTimeout parameter determines whether or not the datalogger will hang up the COM310 after the timeout in the VoiceKey instruction expires.

5.2.1.4 VoiceNumber

The VoiceNumber instruction returns the accumulated touch tone digits that are received prior to the receipt of a # or * key. The example voice callback/callin program uses no VoiceNumber instructions; however, this instruction may be useful for phone transfer of long numbers such as for passwords, etc.

5.2.1.5 DialVoice

The DialVoice instruction is used to define the dialing string for a COM310 voice modem, usually for voice callback. If the DialVoice instruction is set equal to a variable, a True will be returned if the communication attempt was successful or a False will be returned if it failed. VoiceHangup is used after a communication attempt to hang up the voice modem. The DialString is the telephone number and any other codes used to dial the modem. The DialString can be a variable. A comma in the DialString inserts a 2 second pause.

5.2.1.6 VoiceHangup

The VoiceHangup instruction is used most often with the DialVoice instruction to hang up the modem after communication. The VoiceHangup instruction is not needed if the voice commands are enclosed within the VoiceBeg / EndVoice instructions.

5.2.1.7 VoiceSetup

The VoiceSetup instruction controls the hang up of the COM310 voice modem. It also allows you to specify certain handset key functions.

The HangUpKey parameter specifies the key that, when pressed, will disconnect the COM310.

The ExitSubKey parameter specifies the key that will exit a subroutine if the datalogger is running one. The ContinueKey parameter specifies the key that will begin announcing the next VoiceSpeak phrase.

The SecsOnLine parameter specifies the maximum number of seconds that the COM310 will be off-hook before it is hung up by the datalogger.

The UseTimeout parameter determines whether or not the datalogger will hang up the COM310 after the timeout in the VoiceKey instruction expires. If this parameter is set to True, the timeout will be used. If False, the timeout will not be used.

The CallOut parameter is a Boolean value that indicates the COM310 mode. When the value returned in this parameter is True the datalogger has called out. When the value is False the datalogger has received an incoming call.

If the same ASCII character is used for HangUpKey and ExitSubKey, the datalogger will exit a subroutine if it is in one, otherwise, it will hang up the COM310. When the specified ContinueKey is pressed, the COM310 will skip the current VoiceSpeak string and move to the next one. If any other key is pressed, the COM310 will skip to the next group of VoiceSpeak instructions.

5.2.2 Data Callback

The COM310 can be put into data mode to accomplish data callback, instructing LoggerNet to do a collection of datalogger data.

5.2.2.1 Example Data Callback Program

The following program (downloadable from CSI web site under Support/Download/Program Examples) does data callbacks to the phone number associated with the DialModem instruction whenever the TC temperature exceeds 85F. To complete the system, provide a PC running LoggerNet with a phone modem connected to the phone line dialed.

```
' CR1000 Series Datalogger
' BASIC_DATA_CLBK_1.CR1
' Program description: Does a DATA CALLBACK via COM310 when DIFF 7 TC temp > 85F
' LoggerNet Map:
' ComPort
' PhoneBase
' PhoneRemote
' PakBusPort
' CR1000 (PakBus Address matches remote DL)
' Use Type T thermocouple or change TCDiff instruction accordingly

Public batt_volt, Result
Public PTemp, TCvalue_F, dummy
Dim DialSuccess

DataTable (TestA,1,1000)
DataInterval (0,0,Sec,10)
Sample (1,PTemp,FP2)
Sample (1,TCvalue_F,FP2)
Sample (1,batt_volt,FP2)
Sample (1,DialSuccess,FP2)
Sample (1,Result,FP2)
EndTable
```

```

DataTable (TestB,1,1000)
  DataInterval (0,0,Sec,10)
  Sample (1,PTemp,IEEE4)
  Sample (1,TCvalue_F,IEEE4)
  Average (1,TCvalue_F,IEEE4,False)
  Sample (1,batt_volt,FP2)
  Sample (1,DialSuccess,FP2)
  Sample (1,Result,FP2)
EndTable

DialSequence (4094)
  DialSuccess = DialModem (Com310, 9600,"1112223333","")  'Phone number to call
EndDialSequence (DialSuccess)

BeginProg
  Scan (30,Sec,0,0)

  PanelTemp (PTemp,250)
  Battery (Batt_volt)
  dummy = 0

  TCDiff (TCvalue_F,1,mV2_5C,7,TypeT,PTemp,True ,0,250,1.8,32)

  If TCvalue_F > 85 then
    SendVariables (Result,Com310,4094,4094,0000,2500,"Public","Callback",dummy,1)
    Delay (1,15,Sec)  'Prevents too soon callback
  Endif

  CallTable TestA
  CallTable TestB

  NextScan
EndProg

```

In the above data callback program, the phone number is dialed in the DialSequence/EndDialSequence using the DialModem instruction. Any needed re-dials are handled by EndDialSequence (DialSuccess).

LoggerNet recognizes the incoming call as a data callback by the arrival of the "Public" and "Callback" strings sent by the SendVariables instruction in the Table and Field parameters (visible in low-level log for ComPort). Callback must be enabled in both the station and the ComPort screens.

The 25 second SendVariables timeout (2500 hundredths of a sec) allows the slow phone connection time to build.

The program should be available for download from our website under Support/Downloads/Program Examples.

5.2.2.1 Data Callback Instructions

The following instructions are used to program a data callback.

DialSequence/EndDialSequence

The DialSequence/EndDialSequence instructions are used to define the code necessary to route packets to a PakBus datalogger. Any time an instruction (SendVariables) in the main program requires that communication be made with the remote PakBus device identified by the PakBusAddr parameter (LoggerNet server with PakBus address = 4094), the DialSequence code for that datalogger will be executed.

DialModem

The DialModem instruction is used to send a modem dial string out one of the datalogger's ports. DialModem can be used within DialSequence / EndDialSequence to specify a communication route to be used for a PakBus device.

The ResponseString is used to specify the response code expected back from the modem when a connection is made. When a null string is entered (""), the default is "1"+ CHR(13).

SendVariables

The SendVariables instruction is used to send value(s) from a variable or variable array to a data table in a destination PakBus device.

In the example data callback program, the variable "dummy" is sent to LoggerNet as a signal for LoggerNet to begin collection of the datalogger.

5.3 Edlog Dataloggers and LoggerTalk

To program a voice capable mixed-array or PakBus Edlog datalogger for voice communications, voice codes are appended to the datalogger's *.dld file. LoggerTalk software is shipped with the COM310 to accomplish this. LoggerTalk requires a PC running Windows NT/98/ME/2000/XP and equipped with a CD-ROM drive for installation.

5.3.1 Install

To install LoggerTalk, insert the auto-run CD into the drive and follow directions to complete the installation.

5.3.2 Helps and Tutorials

LoggerTalk information is available in its extensive Help system. You can access Help by pressing the F1 key, by selecting Help from the main window, or by clicking the Help button.

Two tutorials are included in LoggerTalk Help. The first is a basic tutorial on creating voice strings, sending the LoggerTalk edited *.dld program to the datalogger, and navigating through the voice modem menus. The second

tutorial is a more advanced tutorial for setting up voice callback. Example program files are included for use in the tutorials. If you've had little experience in creating/editing datalogger programs in Edlog, we suggest that you begin with Quick Start (Section 3) and the basic LoggerTalk tutorial, referring to the Help system with any questions you might have.

For a guide to interpreting the voice codes that LoggerTalk appends to a *.dld program, see Appendix F of this manual.

5.3.3 Modem Security Code

A "Modem Security Code" can be assigned which allows a caller to hear only the initial message(s) and prevents access to further data and control unless the modem security code is presented. If a modem security code is not assigned, by default all callers will have access to input locations, and can check status and toggle datalogger ports and flags. The assignment of a modem security code is done in LoggerTalk. The code becomes part of the associated *.dld program when you click "Save Edits." Refer to the LoggerTalk help system for more information.

If you should forget an assigned modem security code, you can run LoggerTalk, open (associate) the datalogger program file and obtain the assigned modem security code from the main menu.

NOTE

LoggerTalk's Modem Security Code is unrelated to the Datalogger's *C mode passwords. For more information on the datalogger's *C mode, please refer to the datalogger operator's manual.

5.3.4 Commercial Mode

If you use LoggerTalk to put your voice communications system in "Commercial Mode" the station will then announce the initial message(s) up to two times. It will not prompt the caller to enter the security code. If the correct security code is not presented within about 15 seconds the station will hang up.

A Modem Security Code must be assigned in LoggerTalk in order to program the *.dld file for Commercial Mode. Remember to re-send to the datalogger any *.dld program "Saved and Edited" in LoggerTalk for the changes to take effect.

5.3.5 Custom Menu Strings

When you call a station, after the initial messages are announced you are prompted to select *Input Locations*, *Ports*, or *Flags*. You can use LoggerTalk to rename these prompts. A dialog box to edit the strings is invoked by clicking the "Menu Strings" button in the main LoggerTalk window. Refer to the software help for more information.

5.3.6 Voice Callback

LoggerTalk can program a voice callback when associated with a *.dld file that includes a P97 with Parameter 1 = "31" for mixed-array dataloggers or "39" for PakBus dataloggers (see Section 5.1.1.2).

LoggerTalk allows you to input multiple phone numbers to increase the probability that the alarm message will get through. If the first phone is not 'picked up' then the second number is dialed. If the second number is not picked up then the third number is dialed, etc.

There is a LoggerTalk Help tutorial to guide you through setting up datalogger initiated callback.

5.3.7 View and Remove Voice Code

Although the voice code LoggerTalk adds to a *.dld file is not visible in Edlog, you can open a *.dld file in a text editor such as Notepad[®] and view voice codes appended to the *.dld file. The text editor is only recommended for viewing the file (not editing it). See Appendix F of this manual for a guide to interpreting the voice codes.

To remove voice code from a *.dld file, open it in LoggerTalk, remove all voice strings, and click on "Save Edits."

5.4 LoggerNet

By default the COM310 operates in *voice* mode, enabling you to call a station and hear voice announcements or enabling the station to do a callback to you and announce an alarm. The COM310 also has the ability to function in *data* mode. In data mode, the COM310 supports data collection and other standard LoggerNet functions.

You can set up LoggerNet to call and perform scheduled collections of storage data or you can program the datalogger to do callbacks under the conditions you specify at which time LoggerNet will collect the data.

For scheduled (or manual) collection you change the COM310 to *data* mode by including six commas and a "9" in LoggerNet's dial script in the Setup Screen's Hardware Tab for PhoneRemote.

For callback collection, the CR1000's DialSequence instruction changes the COM310 from default voice mode to data mode. An Edlog datalogger's program P97 with Callback ID puts the COM310 in data mode.

The commas create a delay so that the "9" is received by the COM310 during the voice announcement. When the COM310 detects the "9" it disables *voice* communications and enables data mode for the remainder of that connection.

For example, in LoggerNet, if the phone number is "555-4321" then in order to call the COM310 and enable data mode the dial script becomes:

```
"555-4321,,,,,,9"
```

In LoggerNet a comma represents a 1 second delay. You may need to adjust the number of commas so that the “9” occurs during the voice announcement, depending upon the length of time required to establish the connection with the modem.

For information on creating an Edlog datalogger program and downloading it to the COM310 station, refer to the Basic Tutorial in LoggerTalk help.

6. Hardware Installation

6.1 Site Requirements

NOTE Connection to telephone company provided COIN service (Central Office Implemented systems) is prohibited. Connection to party line service is subject to state tariffs.

The COM310 is compatible with standard (analog) telephone lines. It connects to the telephone line by means of a USOC RJ11C jack (standard modular telephone jack). Connect the cable from the telephone RJ11C jack to the modem as shown in Figure 2.

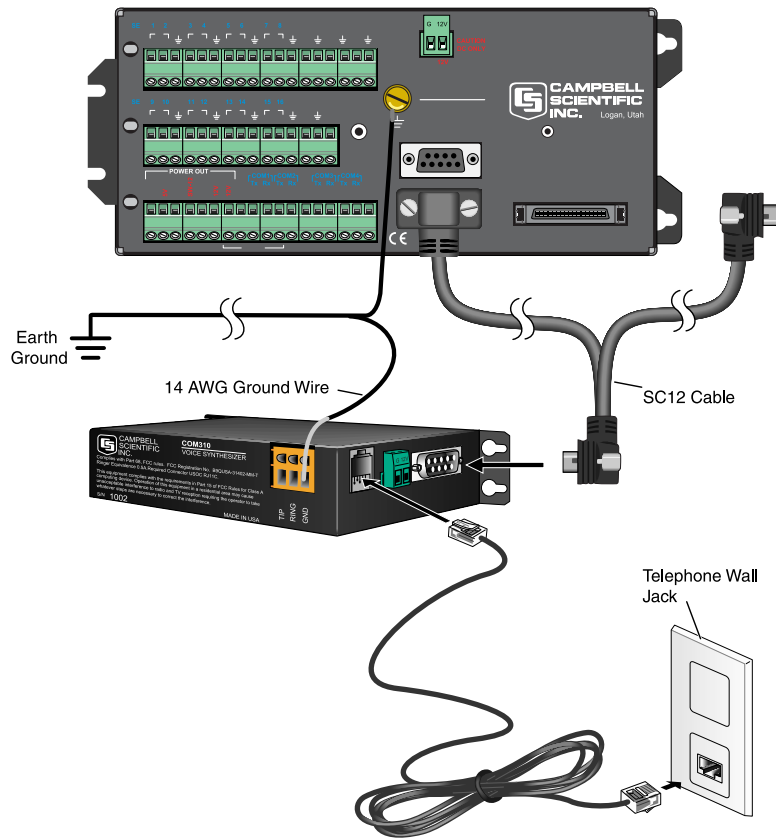

FIGURE 2. COM310 Hardware Connection Using Standard RJ11 Phone Jack

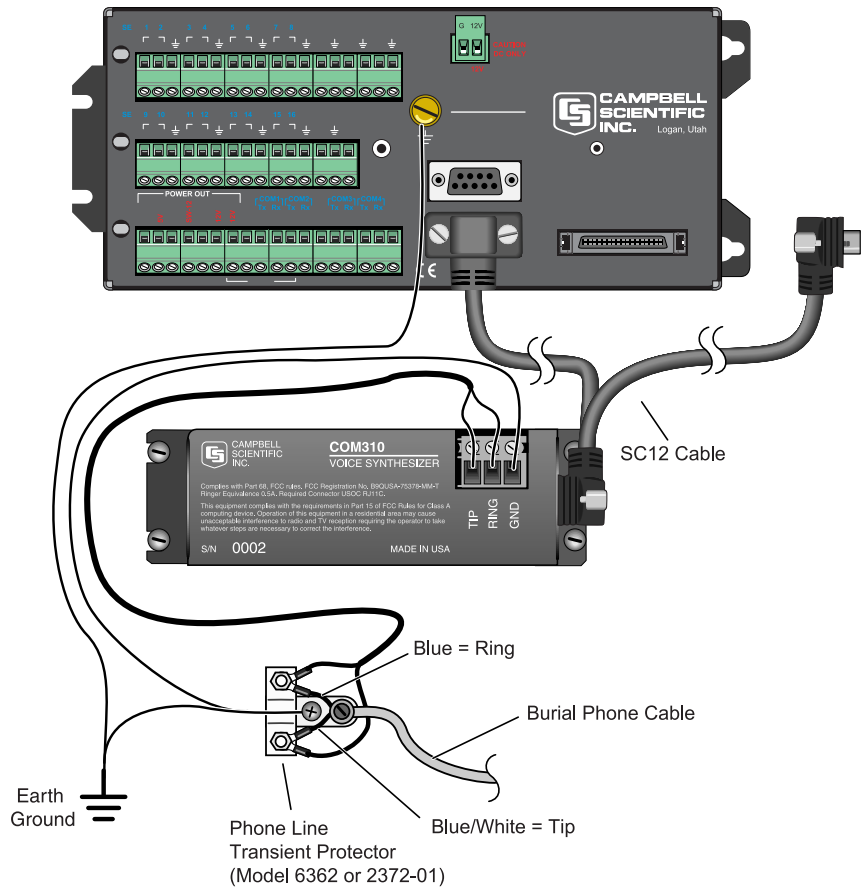

FIGURE 3. COM310 / CR1000 Using Surge Protection Device (where there's no available Standard RJ11 Connection)

6.2 Powering the COM310 Modem

Newer Campbell Scientific dataloggers provide 12 VDC on CS I/O connector pin 8 for powering peripherals such as the COM310. The alternative, if you have a dataloggers/wiring panel lacking 12 VDC on pin 8, is to wire the green connector on the side of the COM310 to the datalogger +12 VDC and power ground terminals (refer to Figure 4). The COM310 comes with a mating green power connector for this purpose. The following Campbell Scientific dataloggers lack 12 VDC power on CS I/O pin 8.

TABLE 1. Dataloggers/Wiring Panels Lacking 12 VDC on CS I/O Port Pin 8
CR10(X) w/ silver wiring panel
CR10(X) w/ black CR10 wiring panel (P/N 8032)
CR500—serial number 1764 or lower

6.3 Grounding the COM310 System

Connect the green 14 AWG grounding wire (provided with the COM310) to the GND terminal on the COM310 and to the station enclosure's earth ground connection. It is important that you connect the COM310 and datalogger directly to a high quality earth ground. Read the datalogger manual section on GROUNDING for details on creating such an earth ground.

WARNING

A quality EARTH GROUND connection to the COM310 and datalogger maximizes protection against electrostatic discharge! Follow carefully the EARTH GROUND scheme in Figure 4. The COM310 employs spark gaps on the phone lines; however, they will be ineffective without quality earth grounding.

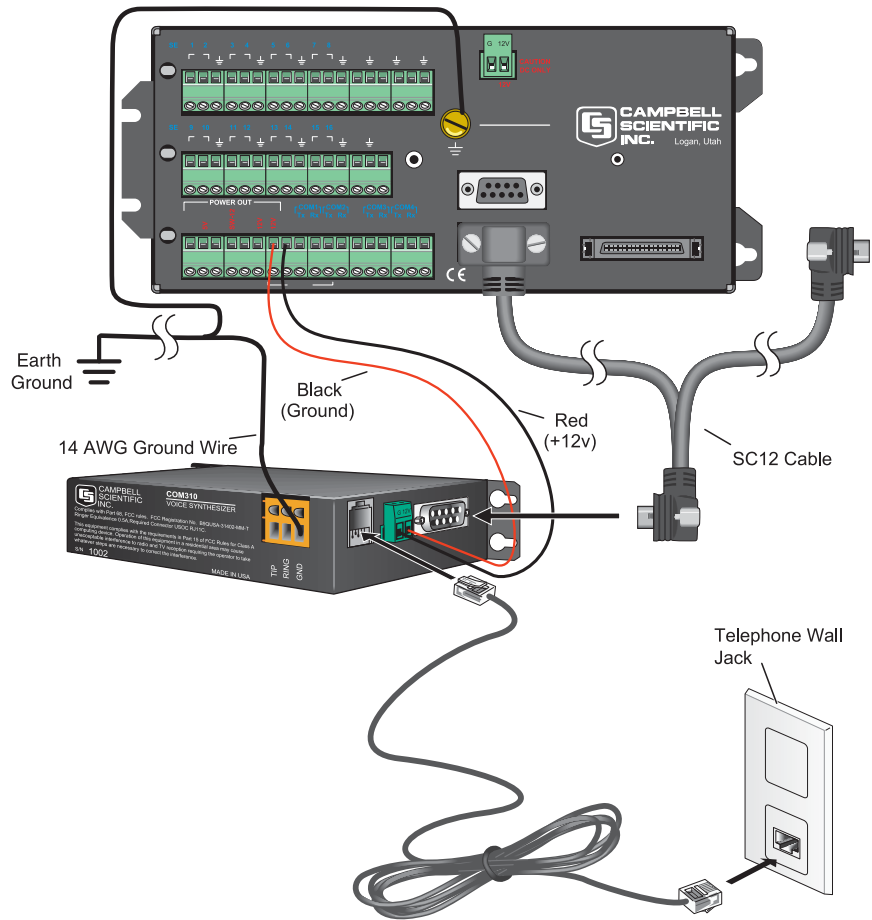

FIGURE 4. COM310 Grounding and Alternate 12VDC Power

6.4 Telephone Service

Telephone companies occasionally make changes in their equipment, operations, or procedures. If you have any questions about your telephone line, such as how many pieces of equipment you can connect to it, the telephone company should be able to furnish this information upon request. If the telephone company requests information from you concerning the equipment that you have connected to your telephone line, the COM310 label shows its FCC registration number and ringer equivalence number (REN). COM310 information pertaining to the FCC and Industry Canada is available in Appendices B and C.

If any of your telephone equipment is malfunctioning, you should remove it immediately from the telephone line as it may damage the telephone network.

If the telephone company notices a problem from their end, they may temporarily discontinue service. They should notify you in advance of disconnection and give you opportunity to correct the problem. If not feasible, they should notify you as soon as possible.

NOTE

If the local phone company does not provide phone-line surge protection, a Campbell Scientific surge suppressor should be used. Refer to Section 6.6 for more information.

6.5 Telephone Transfers

The COM310 has the ability to do certain transfers by telephone:

1. Set/Get AT parameters in COM310's Connexant chip set (Appendix D)
2. Retrieve word list from COM310
3. Install OS to COM310
4. Install new voice word file or add to existing words in COM310

There is some risk in performing such transfers by telephone, especially in regards to *remote* sites. If you have need of doing such a transfer, contact Campbell Scientific for details.

6.6 Connecting to a Surge Protector

Campbell Scientific offers two surge protectors (CSI model 4330 and CSI model 6362). The 4330 and 6362 are essentially the same, except the 6362 has hardware for mounting to an enclosure backplate.

NOTE

The 4330 is also known as the 2374-01.

The 4330 and 6362 have a protector element for each line that consists of a heavy-duty-rated, two-element gas tube, an external backup gap assembly, and a switch-grade shorting mechanism. The gas tubes (tip and ring) are sealed in a fire-resistant plastic body. DC Breakdown @ 100 V/sec is 300 to 500 volts; DC extinguishing @ 52 V, 135 V, and 150 V is less than 150 milliseconds.

Figures 5 and 6 show the wiring for connecting the surge suppressor. Color coding of wires may vary. The important consideration is to follow TIP all the way through and RING all the way through. Getting wires crossed typically does not damage anything. The phone line just will not work until the wires are straightened out.

CAUTION

Phone wires are live, typically with low voltage (24 Vdc). While not harmful in most situations, Campbell Scientific recommends installing the surge protector in dry weather only by technicians with a healthy heart.

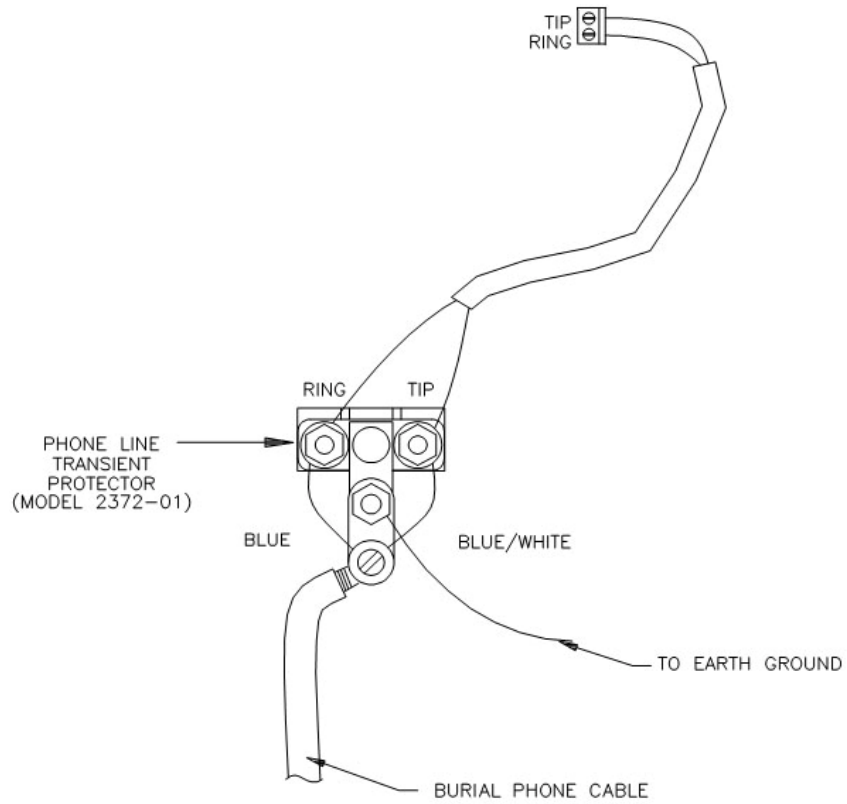

FIGURE 5. Top View of Surge Suppressor Wiring

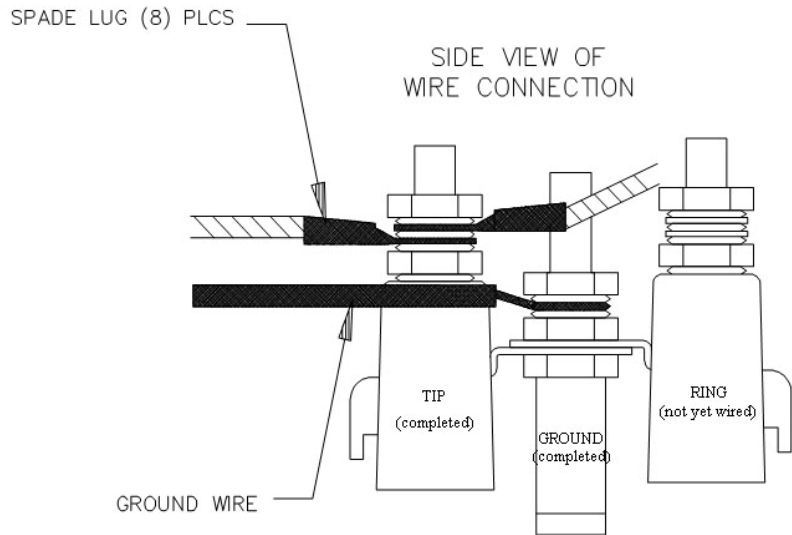

FIGURE 6. Side View of Surge Suppressor Wiring

7. Troubleshooting COM310 Voice Systems

Following are some possible reasons for your COM310 system not working or not working properly.

7.1 No Communications

Voice Mode — No voice announcements when you call the station

- 1) The COM310 not getting 12V power due to an older datalogger/wiring panel that does not provide 12V on CS I/O pin 8.
- 2) The COM310 is connected to a digital rather than an analog phone line.
- 3) The COM310 configuration was changed from its default factory settings (see Appendix D).

Data Mode — Can't connect to the station with LoggerNet software.

- 1) No commas and/or "9" added to the dial string in LoggerNet to temporarily put the COM310 into *data* mode.
- 2) The "9" is being dialed before the COM310 'picks up' and voices the announcement (not enough commas).
- 3) No phone number in the LoggerNet dial string.
- 4) COM310 not getting 12V power due to older datalogger/wiring panel that does not provide 12V on CS I/O pin 8.
- 5) COM310 is connected to a digital rather than an analog phone line.

- 6) LoggerNet Setup configured for the wrong PC modem.
- 7) LoggerNet configured for a baud rate the station cannot handle (try 9600).
- 8) COM310 configuration was changed from its default factory settings (see Appendix D).

7.2 Communications Problems

Voice Mode

- 1) Can't get beyond the initial voice announcement
 - a) Security mode is enabled (Edlog datalogger).
 - b) Commercial mode is enabled (Edlog datalogger).
 - c) Datalogger is running a *.dld program which hasn't been 'edited and saved' in LoggerTalk. You can open (associate) the *.dld file in LoggerTalk and see if there is voice code.
 - d) The security code was not received. Try pressing # again, then xxx# again (where xxx = modem security code).
- 2) Pressing handset keys sometimes fails to produce the correct response.
 - a) Handset keys not being pressed long enough.
 - b) Key presses (especially # #) were not spaced far enough apart and the station is waiting for the last key (#).
 - c) Phone line introducing excessive noise or signal attenuation.
 - d) Handset introducing excessive noise or producing too low signal levels.
- 3) Station has become unresponsive (try the following in the order given).
 - a) Press # which will usually announce the current menu again.
 - b) Press five or more * (star) keys in rapid succession to recover (CRBasic dataloggers).
 - c) Allow station to time out and disconnect (usually 15 – 40 sec, rarely 5 min), then call again (CRBasic dataloggers).
- 4) Volume levels vary.

This is normal due to the PCM voice encoding compression scheme. Sometimes the modem will negotiate a higher volume for a given connection.

Appendix A. Theory of Operation

The COM310 modem is used to transmit data over bandwidth-limited channels such as telephone lines by modulating audio tones, using Phase Shift Keying (PSK) at 9600 or 1200 baud and Frequency Shift Keying (FSK) at 300 baud.

The COM310 has four connectors:

1. RJ11 – telephone line
2. Orange Tip, Ring, GND – alternate telephone line and EARTH GROUND
3. CS I/O – datalogger serial comms and 12 VDC power if more recent wiring panel (see Section 6.2)
4. Green Power – 12 VDC (alternate in case wiring panel doesn't furnish 12 VDC power)

The telephone company places a 40 to 150 V_{RMS} 20 Hz signal on the telephone line to signify a ring, which is typically on for 2 seconds and off for 4 seconds. The COM310's ring detection circuit is continuously powered but draws less than 2 μA . The COM310 passes a detected ring signal on to the datalogger through an opto-coupler. The datalogger responds by addressing the COM310 synchronously (pins 6 and 7) which switches on 5 VDC power to the COM310. The COM310 then negotiates a connection with the calling modem and remains 'off-hook' until it loses the carrier or until the datalogger sends it a shutdown command. The datalogger sends the COM310 a shutdown command upon receipt of an E (end call) command, after 40 seconds without receiving any command or if the VoiceSetup SecsOnLine setting times out. The shutdown command switches off internal 5 VDC power to the COM310, dropping power to the off-hook relay and 'hanging up.'

To reject noise common to both telephone lines and to satisfy registration requirements, the modem circuits are electrically isolated from the telephone lines by using an opto-isolator and coupling transformer.

Appendix B. FCC Warning to Users of Class A Computing Devices

WARNING

This equipment generates, uses, and can radiate radio frequency energy, and if not installed and used in accordance with the instruction manual, may cause interference to radio communications. It has been tested and found to comply with the limits for a Class A computing device pursuant to Subpart J of Part 15 of FCC Rules, which are designed to provide reasonable protection against such interference when operated in a COMMERCIAL ENVIRONMENT. Operation of this equipment in a residential area may cause interference to radio and television reception. The operator must take whatever measures are necessary to correct the interference.

The REN is used to determine the quantity of devices which may be connected to the telephone line. Excessive REN's on the telephone line may result in the devices not ringing in response to an incoming call. In most, but not all areas, the sum of the REN's should not exceed five (5.0). To be certain of the number of devices that may be connected to the line, as determined by the total REN's, contact the telephone company to determine the maximum REN for the calling area.

This equipment cannot be used on the telephone company-provided coin service. Connection to Party Line Service is subject to State Tariffs.

If this equipment cannot be used on the telephone network, the telephone company will notify you in advance that temporary discontinuance of service may be required. If advance notice isn't practical, the telephone company will notify the customer as soon as possible. Also, you will be advised of your right to file a complaint with the FCC if you believe it is necessary.

Appendix C. IC Information

NOTE

Industry Canada (IC) was formerly known as DOC.

CP-01, Issue 8, Part I Section 14.1

“NOTICE: The Industry Canada label identifies certified equipment. This certification means that the equipment meets certain telecommunications network protective, operational and safety requirements as prescribed in the appropriate Terminal Equipment Technical Requirements document(s). The Department does not guarantee the equipment will operate to the user’s satisfaction.

“Before installing this equipment, users should ensure that it is permissible to be connected to the facilities of the local telecommunications company. The equipment must also be installed using an acceptable method of connection. The customer should be aware that compliance with the above conditions may not prevent degradation of service in some situations.

“Repairs to certified equipment should be coordinated by a representative designated by the supplier. Any repairs or alterations made by the user to this equipment, or equipment malfunctions, may give the telecommunications company cause to request the user to disconnect the equipment.

“Users should ensure for their own protection that the electrical ground connections of the power utility, telephone lines and internal metallic water pipe system, if present, are connected together. This precaution may be particularly important in rural areas.

CAUTION

Users should not attempt to make such connections themselves, but should contact the appropriate electric inspection authority, or electrician, as appropriate.”

CP-01, Issue 8, Part I Section 14.2

“NOTICE: The Ringer Equivalence Number (REN) assigned to each terminal device provides an indication of the maximum number of terminals allowed to be connected to a telephone interface. The termination on an interface may consist of any combination of devices subject only to the requirement that the sum of the Ringer Equivalence Numbers of all the devices does not exceed 5.”

Appendix D. Set Rings, AT Parameters

D.1 Set Number of COM310 Rings before Answer

To program the number of rings before the COM310 answers, use the datalogger's *D3 setting. Changing the COM310's ATSO setting (as with the COM210) will not change the number of rings before answer.

*D3 setup for the CR10X, CR23X, or CR510:

- (1) Key in *D3A
- (2) Key in 1, 2, or 3 according to desired number of rings
- (3) Press A
- (4) Key in *0 to compile

D.2 Telephone Connection to COM310

CAUTION

Changing the COM310's AT settings may result in communication problems or loss of communications requiring retrieval of COM310 from remote site and return to factory for non-warranty work. We recommend that you test a setting change locally before changing it remotely.

Also, there is the slight risk of phone line noise causing erroneous setting changes to occur.

The following describes how to view and change AT parameters of the COM310's Conexant chipset via telephone. See above CAUTION.

The following assumes that your PC has an internal or external modem connected.

(1) Step 1

Run HyperTerminal[®] or similar terminal program

(2) Step 2

(a) Click on File \ New Connection

(b) In the Connection Description window type a name such as "COM310_94." Click on "OK."

(c) Select a configured modem in "Connect Using"
Enter COM310's phone number followed by ".,.,.,9,4".
Example: 750-1234.,.,.,9,4 Click on "OK."

(d) Click on Modify\Configure\General Tab and select Maximum Speed of 9600.

(e) Press "OK"

(3) Step 3

- (a) Dial the phone number
- (b) Wait until “Connected” appears at lower-left on screen. You will hear some tones as a modem connection is established.
- (c) After connection HyperTerminal should display:
ATA
- (d) Wait until you see the “>” prompt
- (e) Type a couple of <CR>s until you see “+++”
- (f) HyperTerminal should then display:
OK
ATO
CONNECT 9600

>

- (g) At the “>” prompt you can type AT commands to the Conexant chipset in your COM310. See CAUTION.

There is a summary of AT commands in the COM210 Instruction Manual, Appendix A available on CSI’s web site.

- (h) To see version number of the COM310 OS, type, “HOS”. You should see “H8 OS mm.dd.yy” on the terminal screen.
- (i) To quit, type “ATH” <ENTER> and wait until “Disconnected” appears at lower-left on screen. This may take a half minute or so.
- (j) Save your HyperTerminal connection setup by clicking on “File” and then “Save.” Thereafter you can start on Step 3.

Appendix E. CS I/O 9 Pin Serial Port

NOTE The COM310's CS I/O port is not a standard RS-232 connection.

Pin Description

The COM310 modem connects to the datalogger using an SC12 cable connected to the datalogger's CS I/O port. The COM310's connector configuration is shown in Figure E-1. Table E-1 shows the I/O pin configuration, and gives a brief description of the function of each pin.

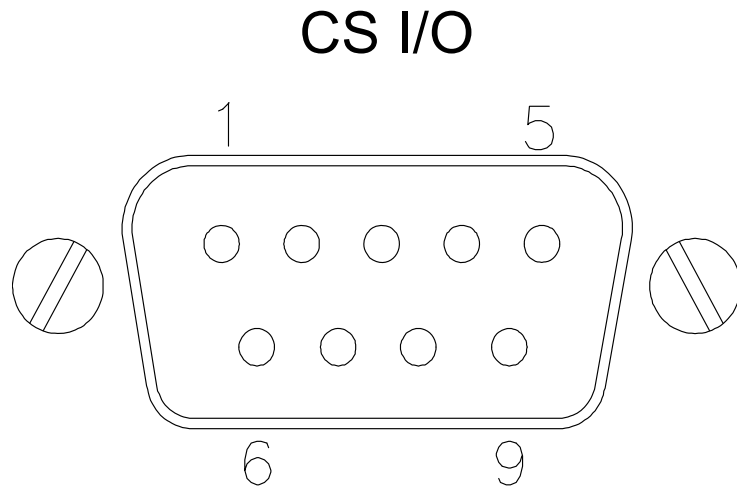

FIGURE E-1. COM310's Male 9 Pin Connector

TABLE E-1. Pin Description			
ABR = Abbreviation for the function name.			
PIN = Pin number.			
O = Signal Out of the datalogger to a peripheral.			
I = Signal Into the datalogger from a peripheral.			
PIN	ABR	I/O	Description
1	5V	I	5 VDC supply (not used for COM310).
2	SG		Signal Ground: Provides a power return for pin 1 (5V), and is used as a reference for voltage levels.
3	RING	O	Ring: Raised by the modem to put the datalogger in the telecommunications mode.
4	RXD	O	Receive Data: Serial data transmitted by the modem are transmitted on pin 4.
5	ME	I	Modem Enable: A logic high internally switches power to the modem. A logic low internally powers down the modem.
6	SDE	I	Synchronous Device Enable: A logic high disables communication with the modem, without removing power or changing the modem's mode.
8	TE	I	+12 VDC power supply.
9	TXD	I	Transmit Data: Serial data are transmitted from the datalogger to the modem on pin 9; logic low marking (0V) logic high spacing (5V) standard asynchronous ASCII, 8 data bits, no parity, 1 start bit, 1 stop bit, 300, 1200, 9600, 76,800 baud (user selectable).

Appendix F. Reading Voice Code in a *.DLD File

When a CR10X, CR23X, or CR510 file is edited and saved in LoggerTalk, the information for voice communications is appended to the *.DLD file. This information can be verified for accuracy.

An example of some typical voice code is shown below. The numbers between the "smiley faces" (☺) and the "&" symbols are the numbers associated with the words used from the word list. The ☺ symbol is equivalent to control code A (^A). Refer to Appendix G to view the word list used with the COM310.

Several lines of code that begin with a tilde (~) may precede the voice code. These strings are setup information. The voice code follows this information. The first line of the voice code is the wording used for input locations. The second line is the wording used for ports. The third line is the wording used for flags. The lines following are used for message descriptions. Each message will terminate with a period.

Notice that line four below starts with ">\4". The > indicates the string is an initial message. The 4 following the slash indicates the number of digits following the decimal point that the COM310 will announce for that input location.

The numbers inside the quotation marks are the words associated with the input location.

The number following the "\$" symbol is the input memory location number used in the datalogger.

F.1 Typical Voice Code

Following is code for a typical call:

```
;|#"☺56&☺57&"#  
#"☺53&"#  
#"☺52&"#  
>\4☺88&☺89&☺109&☺74&☺71&☺71&☺71&"☺109&☺135&☺86&  
"☺85&$3☺87&☺122&\  
\4"☺109&☺98&☺191&"☺85&$1☺192&\  
|  
♣♣
```

The above code translates to:

Input Locations

Ports

Flags

(four decimal places) Campbell Scientific Datalogger Program (pause)
(pause) (pause) "Datalogger Internal Temperature" is (input location 3)
Degrees Fahrenheit.

(four decimal places) Datalogger Battery Voltage is (input location 1) Volts.

F.2 Callback Code

If the datalogger has been programmed to initiate voice calls, you will see the phone number associated with the call command at the very end of the listing. The flag number used to initiate the call and the phone number will be between "at" symbols (@).

This example initiates a voice call:

```
;|#"Ⓢ56&Ⓢ57&"#  
#"Ⓢ53&"#  
#"Ⓢ52&"#  
><2\4"Ⓢ98&Ⓢ191&"Ⓢ85&$1Ⓢ192&\  
@2555-1234@  
|  
♣♣
```

Line four, above, starts out as "><2/4". The ">" means this message is selected as an initial message. The "<2" indicates that this message will be spoken if flag 2 is the flag that initiates callback. The "2" preceding the phone number "@2555-1234@" means the phone number (555-1234) will be called when flag 2 goes high in the program.

The code translates as:

Input Locations

Ports

Flags

(flag 2) (4 decimal places) "Battery Voltage" Is (input location 1) Volts.

(callback flag 2) (telephone number 555-1234)

F.3 Modem Security Enabled

NOTE

LoggerTalk's Modem Security Code is unrelated to the Datalogger's *C mode passwords. Refer to the datalogger operator's manual for more information on the datalogger's *C mode.

This last example uses the modem security code "1234" to allow access to the second level menu. Notice the characters following the "?" at the beginning of the character stream. The security code will always be the very first thing in the imbedded character portion of the *.DLD file.

```
;|?1234#"Ⓢ56&Ⓢ57&"#
```

```
#"Ⓢ53&"#
```

```
#"Ⓢ52&"#
```

```
>\4Ⓢ88&Ⓢ89&Ⓢ109&Ⓢ74&Ⓢ71&Ⓢ71&Ⓢ71&"Ⓢ109&Ⓢ135&Ⓢ86&  
"Ⓢ85&$3Ⓢ87&Ⓢ122&.\
```

```
\4"Ⓢ109&Ⓢ98&Ⓢ191&"Ⓢ85&$1Ⓢ192&.\
```

This code translates to:

(security code 1234) Input Locations

Ports

Flags

(4 decimal places) Campbell Scientific Datalogger Program (pause)
(pause) (pause) "Datalogger Internal Temperature" Is (input location 3)
Degrees Fahrenheit.

(4 decimal places) "Datalogger Battery Voltage" Is (input location 1)
Volts.

Appendix G. COM310 Word List

G.1 COM310 Word List - Numerical Order

0. ZERO	47. PREVIOUS	94. AT
1. ONE	48. STATUS	95. AVERAGE
2. TWO	49. HIGH	96. BAROMETRIC
3. THREE	50. LOW	97. BARS
4. FOUR	51. TOGGLE	98. BATTERY
5. FIVE	52. FLAGS	99. CALIBRATE
6. SIX	53. PORTS	100. CELSIUS
7. SEVEN	54. THRU	101. CENTI
8. EIGHT	55. PORT	102. CHILL
9. NINE	56. INPUT	103. CLOSED
10. TEN	57. LOCATIONS	104. CONDUCTIVITY
11. ELEVEN	58. FLAG	105. CUBIC
12. TWELVE	59. AND	106. CURRENT
13. THIRTEEN	60. OF	107. DAM
14. FOURTEEN	61. SECURITY	108. DATA
15. FIFTEEN	62. CODE	109. DATALOGGER
16. SIXTEEN	63. YOUR	110. DAY
17. SEVENTEEN	64. POINT	111. DEPTH
18. EIGHTEEN	65. PLEASE	112. DEVIATION
19. NINETEEN	66. BY	113. DIRECTION
20. TWENTY	67. MINUS	114. D-O
21. THIRTY	68. ENTER	115. DOWN
22. FORTY	69. SELECTION	116. DRAW
23. FIFTY	70. GOODBYE	117. EQUAL
24. SIXTY	71. 50MS	118. E-T-O
25. SEVENTY	72. MESSAGE	119. EVENT
26. EIGHTY	73. CALLBACK	120. EXTERNAL
27. NINETY	74. PROGRAM	121. EXCEEDS
28. HUNDRED	75. SIGNATURE	122. FAHRENHEIT
29. THOUSAND	76. EPROM	123. FALL
30. MILLION	77. KILOBYTES	124. FEET
31. PRESS	78. MEMORY	125. FLOW
32. POUND	79. NUMBER	126. FROM
33. DEW	80. E08'S	127. GALLONS
34. HEAR	81. TABLE	128. GRAM
35. MENU	82. OVERRUNS	129. HELLO
36. AGAIN	83. VERSION	130. SET
37. STAR	84. REVISION	131. HOUR
38. DISCONNECT	85. IS	132. HUMIDITY
39. YOU	86. TEMPERATURE	133. IN
40. THE	87. DEGREES	134. INCHES
41. HAVE	88. CAMPBELL	135. INTERNAL
42. SELECTED	89. SCIENTIFIC	136. KILO
43. MONITOR	90. ACRE	137. LAST
44. KEY	91. AIR	138. LEVEL
45. FOLLOWING	92. ALARM	139. LITER
46. RETURN	93. ARE	140. RESET

141. MAXIMUM	195. WATTS	249. DURING
142. MERCURY	196. WEATHER	250. E
143. METER	197. WELL	251. EAST
144. METERS	198. WIND	252. EASTERN
145. MICRO	199. A	253. EFFLUENT
146. MILES	200. A-M	254. ELECTRON
147. MILLI	201. ABOVE	255. ELEVATION
148. MINIMUM	202. ACCUMULATE	256. EMPTIED
149. MINUTE	203. ACKNOWLEDGE	257. ENGINE
150. MOISTURE	204. ADDITION	258. ERROR
151. MONTH	205. ADDITIONAL	259. F
152. MULTIPLIER	206. AGO	260. FAILED
153. NEW	207. ALL	261. FAILURE
154. N-T-U	208. AMMONIUM	262. FALLING
155. OFF	209. APPROACH	263. FIRST
156. OFFSET	210. AREA	264. FLUORIDE
157. ON	211. AVAILABLE	265. FREEZER
158. OPEN	212. B	266. FREQUENCY
159. OVERFLOW	213. BACK-UP	267. FRIDAY
160. PARTS	214. BAY	268. FUEL
161. PER	215. BE	269. G
162. PERCENT	216. BEAVER	270. GAS
163. P-H	217. BEDS	271. GATE
164. PRECIPITATION	218. BEHIND	272. GAUGE
165. PRESSURE	219. BELOW	273. GENERATOR
166. PROGRESS	220. BIG	274. GOING
167. P-S-I	221. BILLION	275. GOOD
168. RADIATION	222. BLAST	276. GRADIENT
169. RAIN	223. BOILER	277. GRASS
170. RATE	224. BUILDING	278. GROUND
171. REFERENCE	225. C	279. H
172. RELATIVE	226. C-O	280. H-2-S
173. R-P-M	227. CALCIUM	281. HAD
174. SAMPLE	228. CALL	282. HARDNESS
175. SECOND	229. CALLS	283. HAS
176. SECONDS	230. CAN	284. HASH
177. SIEMENS	231. CEMENT	285. HEAD
178. SITE	232. CENTRAL	286. HEAT
179. SNOW	233. CHECK	287. HERTZ
180. SOIL	234. CHILLER	288. HOLD
181. SOLAR	235. CHLORIDE	289. HOT
182. SPEED	236. CHLORINE	290. HOURS
183. SQUARED	237. CONTACT	291. HYDROLOGIC
184. STAGE	238. CORRECTED	292. I
185. STANDARD	239. CROSSING	293. INDEX
186. STATION	240. CYCLES	294. ING
187. STORM	241. D	295. INTAKE
188. TIME	242. DAYS	296. INTRUDER
189. TURBIDITY	243. DELTA	297. IRRADIANT
190. VELOCITY	244. DING	298. IRRIGATION
191. VOLTAGE	245. DISTRICT	299. IT
192. VOLTS	246. DIVERSION	300. J
193. WARNING	247. DOCK	301. K
194. WATER	248. DOOR	302. KNOTS

303. L	347. POND	391. SUNBURN
304. LAKE	348. POTASSIUM	392. SUNDAY
305. LAYER	349. POWDER	393. SURFACE
306. LINE	350. POWER	394. SURFACTANCE
307. LOAD	351. PREHEAT	395. SYSTEM
308. LOCATED	352. PROBE	396. T
309. LOCATION	353. PRODUCT	397. TAIL
310. LOGAN	354. PUMP	398. TESTING
311. M	355. Q	399. THANK
312. M-R-P	356. QUALITY	400. THAT
313. MANAGEMENT	357. QUIT	401. THIS
314. MENDON	358. R	402. THRESHOLD
315. MID	359. RACE	403. THURSDAY
316. MID-MOUNTAIN	360. RADIAL	404. TING
317. MIDNIGHT	361. RANGE	405. TO
318. MINUTES	362. REACHED	406. TODAY
319. MODEM	363. READING	407. TODAYS
320. MONDAY	364. RECEIVED	408. TOTAL
321. MOUNT	365. RESERVOIR	409. TRIGGERED
322. MOUNTAIN	366. RESIDUAL	410. TUESDAY
323. N	367. RISING	411. U
324. NEEDS	368. RIVER	412. ULTRAVIOLET
325. NETWORK	369. ROAD	413. UNITS
326. NEXT	370. ROOM	414. UP
327. NITRATE	371. RUN	415. V
328. NITROGEN	372. RUNOFF	416. V-O-C
329. NO	373. S	417. VALUE
330. NOON	374. S-O-2	418. VERTICAL
331. NORTH	375. SATURDAY	419. VIA
332. NOT	376. SEDIMENT	420. W
333. O	377. SENSOR	421. WAS
334. OK	378. SENSORS	422. WE
335. OR	379. SHAFT	423. WEDNESDAY
336. OUT	380. SINCE	424. WELCOME
337. OZONE	381. SKIING	425. WEST
338. P	382. SMOG	426. WHAT
339. P-M	383. SODIUM	427. WITH
340. PACIFIC	384. SONAR	428. X
341. PARAMETER	385. SOUTH	429. Y
342. PAST	386. SPILL	430. YEAR
343. PEAK	387. STATES	431. YESTERDAY
344. PENDING	388. STREAMBED	432. Z
345. PHONE	389. SUMMIT	
346. PLANT	390. SUMP	

G.2 COM310 Word List - Alphabetical Order

71. 50MS	203. ACKNOWLEDGE	206. AGO
199. A	90. ACRE	91. AIR
200. A-M	204. ADDITION	92. ALARM
201. ABOVE	205. ADDITIONAL	207. ALL
202. ACCUMULATE	36. AGAIN	208. AMMONIUM

59. AND	108. DATA	264. FLUORIDE
209. APPROACH	109. DATALOGGER	45. FOLLOWING
93. ARE	110. DAY	22. FORTY
210. AREA	242. DAYS	4. FOUR
94. AT	87. DEGREES	14. FOURTEEN
211. AVAILABLE	243. DELTA	265. FREEZER
95. AVERAGE	111. DEPTH	266. FREQUENCY
212. B	112. DEVIATION	267. FRIDAY
213. BACK-UP	33. DEW	126. FROM
96. BAROMETRIC	244. DING	268. FUEL
97. BARS	113. DIRECTION	269. G
98. BATTERY	38. DISCONNECT	127. GALLONS
214. BAY	245. DISTRICT	270. GAS
215. BE	246. DIVERSION	271. GATE
216. BEAVER	247. DOCK	272. GAUGE
217. BEDS	248. DOOR	273. GENERATOR
218. BEHIND	115. DOWN	274. GOING
219. BELOW	116. DRAW	275. GOOD
220. BIG	249. DURING	70. GOODBYE
221. BILLION	250. E	276. GRADIENT
222. BLAST	118. E-T-O	128. GRAM
223. BOILER	80. E08'S	277. GRASS
224. BUILDING	251. EAST	278. GROUND
66. BY	252. EASTERN	279. H
225. C	253. EFFLUENT	280. H-2-S
226. C-O	8. EIGHT	281. HAD
227. CALCIUM	18. EIGHTEEN	282. HARDNESS
99. CALIBRATE	26. EIGHTY	283. HAS
228. CALL	254. ELECTRON	284. HASH
73. CALLBACK	255. ELEVATION	41. HAVE
229. CALLS	11. ELEVEN	285. HEAD
88. CAMPBELL	256. EMPTIED	34. HEAR
230. CAN	257. ENGINE	286. HEAT
100. CELSIUS	68. ENTER	129. HELLO
231. CEMENT	76. EPROM	287. HERTZ
101. CENTI	117. EQUAL	49. HIGH
232. CENTRAL	258. ERROR	288. HOLD
233. CHECK	119. EVENT	289. HOT
102. CHILL	121. EXCEEDS	131. HOUR
234. CHILLER	120. EXTERNAL	290. HOURS
235. CHLORIDE	259. F	132. HUMIDITY
236. CHLORINE	122. FAHRENHEIT	28. HUNDRED
103. CLOSED	260. FAILED	291. HYDROLOGIC
62. CODE	261. FAILURE	292. I
104. CONDUCTIVITY	123. FALL	133. IN
237. CONTACT	262. FALLING	134. INCHES
238. CORRECTED	124. FEET	293. INDEX
239. CROSSING	15. FIFTEEN	294. ING
105. CUBIC	23. FIFTY	56. INPUT
106. CURRENT	263. FIRST	295. INTAKE
240. CYCLES	5. FIVE	135. INTERNAL
241. D	58. FLAG	296. INTRUDER
114. D-O	52. FLAGS	297. IRRADIANT
107. DAM	125. FLOW	298. IRRIGATION

85. IS	324. NEEDS	165. PRESSURE
299. IT	325. NETWORK	47. PREVIOUS
300. J	153. NEW	352. PROBE
301. K	326. NEXT	353. PRODUCT
44. KEY	9. NINE	74. PROGRAM
136. KILO	19. NINETEEN	166. PROGRESS
77. KILOBYTES	27. NINETY	354. PUMP
302. KNOTS	327. NITRATE	355. Q
303. L	328. NITROGEN	356. QUALITY
304. LAKE	329. NO	357. QUIT
137. LAST	330. NOON	358. R
305. LAYER	331. NORTH	173. R-P-M
138. LEVEL	332. NOT	359. RACE
306. LINE	79. NUMBER	360. RADIAL
139. LITER	333. O	168. RADIATION
307. LOAD	60. OF	169. RAIN
308. LOCATED	155. OFF	361. RANGE
309. LOCATION	156. OFFSET	170. RATE
57. LOCATIONS	334. OK	362. REACHED
310. LOGAN	157. ON	363. READING
50. LOW	1. ONE	364. RECEIVED
311. M	158. OPEN	171. REFERENCE
312. M-R-P	335. OR	172. RELATIVE
313. MANAGEMENT	336. OUT	365. RESERVOIR
141. MAXIMUM	159. OVERFLOW	140. RESET
78. MEMORY	82. OVERRUNS	366. RESIDUAL
314. MENDON	337. OZONE	46. RETURN
35. MENU	338. P	84. REVISION
142. MERCURY	163. P-H	367. RISING
72. MESSAGE	339. P-M	368. RIVER
143. METER	167. P-S-I	369. ROAD
144. METERS	340. PACIFIC	370. ROOM
145. MICRO	341. PARAMETER	371. RUN
315. MID	160. PARTS	372. RUNOFF
316. MID-MOUNTAIN	342. PAST	373. S
317. MIDNIGHT	343. PEAK	374. S-O-2
146. MILES	344. PENDING	174. SAMPLE
147. MILLI	161. PER	375. SATURDAY
30. MILLION	162. PERCENT	89. SCIENTIFIC
148. MINIMUM	345. PHONE	175. SECOND
67. MINUS	346. PLANT	176. SECONDS
149. MINUTE	65. PLEASE	61. SECURITY
318. MINUTES	64. POINT	376. SEDIMENT
319. MODEM	347. POND	42. SELECTED
150. MOISTURE	55. PORT	69. SELECTION
320. MONDAY	53. PORTS	377. SENSOR
43. MONITOR	348. POTASSIUM	378. SENSORS
151. MONTH	32. POUND	130. SET
321. MOUNT	349. POWDER	7. SEVEN
322. MOUNTAIN	350. POWER	17. SEVENTEEN
152. MULTIPLIER	164. PRECIPITATION	25. SEVENTY
323. N	351. PREHEAT	379. SHAFT
154. N-T-U	31. PRESS	177. SIEMENS

- | | |
|------------------|------------------|
| 75. SIGNATURE | 51. TOGGLE |
| 380. SINCE | 408. TOTAL |
| 178. SITE | 409. TRIGGERED |
| 6. SIX | 410. TUESDAY |
| 16. SIXTEEN | 189. TURBIDITY |
| 24. SIXTY | 12. TWELVE |
| 381. SKIING | 20. TWENTY |
| 382. SMOG | 2. TWO |
| 179. SNOW | 411. U |
| 383. SODIUM | 412. ULTRAVIOLET |
| 180. SOIL | 413. UNITS |
| 181. SOLAR | 414. UP |
| 384. SONAR | 415. V |
| 385. SOUTH | 416. V-O-C |
| 182. SPEED | 417. VALUE |
| 386. SPILL | 190. VELOCITY |
| 183. SQUARED | 83. VERSION |
| 184. STAGE | 418. VERTICAL |
| 185. STANDARD | 419. VIA |
| 37. STAR | 191. VOLTAGE |
| 387. STATES | 192. VOLTS |
| 186. STATION | 420. W |
| 48. STATUS | 193. WARNING |
| 187. STORM | 421. WAS |
| 388. STREAMBED | 194. WATER |
| 389. SUMMIT | 195. WATTS |
| 390. SUMP | 422. WE |
| 391. SUNBURN | 196. WEATHER |
| 392. SUNDAY | 423. WEDNESDAY |
| 393. SURFACE | 424. WELCOME |
| 394. SURFACTANCE | 197. WELL |
| 395. SYSTEM | 425. WEST |
| 396. T | 426. WHAT |
| 81. TABLE | 198. WIND |
| 397. TAIL | 427. WITH |
| 86. TEMPERATURE | 428. X |
| 10. TEN | 429. Y |
| 398. TESTING | 430. YEAR |
| 399. THANK | 431. YESTERDAY |
| 400. THAT | 39. YOU |
| 40. THE | 63. YOUR |
| 13. THIRTEEN | 432. Z |
| 21. THIRTY | 0. ZERO |
| 401. THIS | |
| 29. THOUSAND | |
| 3. THREE | |
| 402. THRESHOLD | |
| 54. THRU | |
| 403. THURSDAY | |
| 188. TIME | |
| 404. TING | |
| 405. TO | |
| 406. TODAY | |
| 407. TODAYS | |

Campbell Scientific Companies

Campbell Scientific, Inc. (CSI)

815 West 1800 North
Logan, Utah 84321
UNITED STATES
www.campbellsci.com • info@campbellsci.com

Campbell Scientific Africa Pty. Ltd. (CSAf)

PO Box 2450
Somerset West 7129
SOUTH AFRICA
www.csafrica.co.za • cleroux@csafrica.co.za

Campbell Scientific Australia Pty. Ltd. (CSA)

PO Box 444
Thuringowa Central
QLD 4812 AUSTRALIA
www.campbellsci.com.au • info@campbellsci.com.au

Campbell Scientific do Brazil Ltda. (CSB)

Rua Luisa Crapsi Orsi, 15 Butantã
CEP: 005543-000 São Paulo SP BRAZIL
www.campbellsci.com.br • suporte@campbellsci.com.br

Campbell Scientific Canada Corp. (CSC)

11564 - 149th Street NW
Edmonton, Alberta T5M 1W7
CANADA
www.campbellsci.ca • dataloggers@campbellsci.ca

Campbell Scientific Centro Caribe S.A. (CSCC)

300 N Cementerio, Edificio Breller
Santo Domingo, Heredia 40305
COSTA RICA
www.campbellsci.cc • info@campbellsci.cc

Campbell Scientific Ltd. (CSL)

Campbell Park
80 Hathern Road
Shepshed, Loughborough LE12 9GX
UNITED KINGDOM
www.campbellsci.co.uk • sales@campbellsci.co.uk

Campbell Scientific Ltd. (France)

3 Avenue de la Division Leclerc
92160 ANTONY
FRANCE
www.campbellsci.fr • info@campbellsci.fr

Campbell Scientific Spain, S. L.

Avda. Pompeu Fabra 7-9, local 1
08024 Barcelona
SPAIN
www.campbellsci.es • info@campbellsci.es

Please visit www.campbellsci.com to obtain contact information for your local US or International representative.