

**COM300 VOICE COMMUNICATION MODEM
INSTRUCTION MANUAL**

REVISION: 10/02

COPYRIGHT (c) 1994-2002 CAMPBELL SCIENTIFIC, INC.

WARRANTY AND ASSISTANCE

This equipment is warranted by CAMPBELL SCIENTIFIC (CANADA) CORP. ("CSC") to be free from defects in materials and workmanship under normal use and service for **twelve (12) months** from date of shipment unless specified otherwise. ***** **Batteries are not warranted.** ***** CSC's obligation under this warranty is limited to repairing or replacing (at CSC's option) defective products. The customer shall assume all costs of removing, reinstalling, and shipping defective products to CSC. CSC will return such products by surface carrier prepaid. This warranty shall not apply to any CSC products which have been subjected to modification, misuse, neglect, accidents of nature, or shipping damage. This warranty is in lieu of all other warranties, expressed or implied, including warranties of merchantability or fitness for a particular purpose. CSC is not liable for special, indirect, incidental, or consequential damages.

Products may not be returned without prior authorization. To obtain a Return Merchandise Authorization (RMA), contact CAMPBELL SCIENTIFIC (CANADA) CORP., at (780) 454-2505. An RMA number will be issued in order to facilitate Repair Personnel in identifying an instrument upon arrival. Please write this number clearly on the outside of the shipping container. Include description of symptoms and all pertinent details.

CAMPBELL SCIENTIFIC (CANADA) CORP. does not accept collect calls.

Non-warranty products returned for repair should be accompanied by a purchase order to cover repair costs.



CAMPBELL SCIENTIFIC
C A N A D A C O R P .

11564 - 149 street - edmonton - alberta - T5M 1W7
tel 780.454.2505 fax 780.454.2655

www.campbellsci.ca

COM300 Voice Communication Modem Table of Contents

1. Introduction.....	1
2. Hardware and Software Requirements	1
2.1 COM300 Modem.....	1
2.2 Voice Capable Datalogger	2
2.3 Telephone	2
2.4 LoggerTalk Voice Communication Programming Software	2
3. Hardware Installation.....	3
3.1 Site Installation	3
3.2 Properly Grounding the COM300 System	4
3.3 Powering the COM300 Modem.....	4
3.4 Telephone Service.....	5
3.5 Repairs	6
4. LoggerTalk Software Installation.....	6
5. Using the COM300 for Standard Modem Communications in PC208W.....	7
6. Additional Features	7
6.1 Security	7
6.2 Commercial Mode	7
6.3 Renaming Menu Strings for Input Location, Ports, and Flags	7
6.4 Using the COM300 to Hear Output Location Data.....	8
7. Callback - Datalogger Initiated Calls	8
8. Troubleshooting.....	8
8.1 For Problems Encountered When Making Voice Calls	8
8.2 For Problems Encountered When Making Data Calls	9

A. CS I/O 9 Pin Serial Port	A-1
A.1 Pin Description.....	A-1
B. Theory of Operation	B-1
B.1 Theory of Operation	B-1
C. Changing RAM or PROM Chips in the CR10	C-1
C.1 Disassembling the CR10.....	C-1
C.2 Installing New RAM Chips in CR10s with 16K RAM.....	C-1
C.3 Installing New PROM	C-2
D. FCC Warning to Users of Class A Computing Devices	D-1
E. IC Information	E-1
F. Reading Voice Code Information from a *.DLD File	F-1
F.1 Typical Voice Code	F-1
F.2 Callback Code.....	F-2
F.3 Security Enabled	F-3
G. Using P80 to Redirect Final Storage Data to Input Locations	G-1
H. COM300 Word List	H-1
H.1 COM300 Word List - Numerical Order	H-1
H.2 COM300 Word List - Alphabetical Order.....	H-4

List of Figures

1. COM300 Voice Synthesizer Modem	1
2. COM300 Hardware Connection Using Standard RJ11 Telephone Jack	3
3. COM300 Hardware Connection to CR10X Using Surge Protection Device.....	4
4. Providing Alternate Power to the COM300	5
A-1 9 Pin Connector.....	A-1
C-1 Disassembling CR10	C-2
C-2 Jumper Settings for Different RAM Configurations.....	C-3

List of Tables

1. Dataloggers that Require Direct 12 VDC Connection to COM300	5
A-1 Pin Description.....	A-2

COM300 Voice Communication Modem

1. Introduction

The COM300 voice-synthesizer modem allows Campbell Scientific's voice capable dataloggers to transmit, by voice announcement, data stored in input locations and the current status of datalogger control ports and user flags. With voice communication enabled, a user can call a datalogger site and listen to announcements, or the datalogger can be programmed to initiate voice calls when alarm conditions are met. Though voice communication is the primary function of the COM300 modem, the device is also capable of standard modem communications.

This manual provides information specific to the COM300 hardware, including specifications, installation, and operation. Installation of the LoggerTalk Voice Communication Programming Software is covered, but use of the software is detailed in the software's on-line documentation.

2. Hardware and Software Requirements

2.1 COM300 Modem

The COM300 modem (Figure 1) is required at the datalogger site to activate voice communication. The modem is shipped with an SC12 cable (9-pin to 9-pin) to connect it to the datalogger's communication port. Surge protection at the datalogger site is required if it is not installed by the phone company. CSI offers a surge protector with or without environmental enclosure mounting hardware (model 6362 and 2372-01, respectively).

NOTE

The modem's communication port is configured to be compatible with Campbell Scientific's CS I/O port. This is not a standard RS232 connection. Refer to Appendix A for the configuration of this connector.

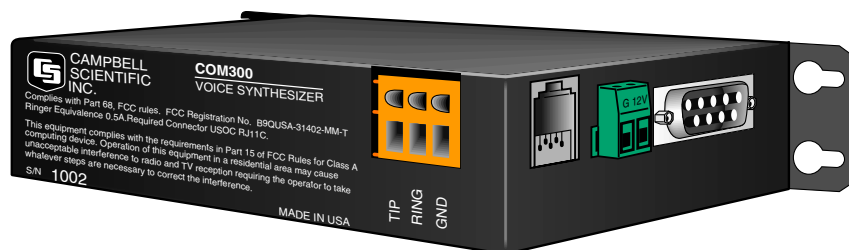

FIGURE 1. COM300 Voice Synthesizer Modem

2.1.1 Specifications

- Bell 212A, CCITT V.22, and V.32BIS compatible
- Full duplex at 9600 and 1200 baud to datalogger
- V.42 LAPM and MNP2-4 error correction
- Hayes AT command set
- RJ-11C telephone jack
- FCC and IC (formally known as DOC) approval
- Pulse or tone dialing
- Current drain: 100 μ A quiescent, 180 mA active
- Direct connection to and powered by CSI dataloggers
- Supply requirements: 12 VDC power supply
- Internally switches 12 VDC external power minimizing current drain
- Logic levels: below 1.5 V inputs a low state and above 3.5 V inputs a high state. A low voltage level on the TX data input (pin 9) and RX data output (pin 4) represents a mark
- Operational temperature: -25°C to +50°C
- Size: 5.2" x 1.7" x 3.6" // 13.1 x 4.3 x 9.2 cm
- Weight: 0.75 lbs // 0.34 kg

For theory of operation for the COM300 modem, refer to Appendix B of this manual.

2.2 Voice Capable Datalogger

The following Campbell Scientific array based dataloggers are capable of voice communication: the CR10, CR10X, CR500, CR510, and CR23X. The CR10 will require a special UVEPROM to enable voice communication. If this special prom was not installed at the factory, please contact Campbell Scientific or your Campbell Scientific representative. Appendix C provides information on installing this UVEPROM.

2.3 Telephone

Typically a touch-tone phone is used to call the COM300 modem. A rotary phone can be used if the programmed verbal announcements do not require the user to navigate through the modem's menu system.

2.4 LoggerTalk Voice Communication Programming Software

Datalogger program files created using Campbell Scientific's Edlog program editor must be modified to include voice communication announcements. This modification is accomplished using LoggerTalk software, which is shipped with all COM300 modems. LoggerTalk requires a computer running Windows 95/NT/98.

3. Hardware Installation

3.1 Site Installation

NOTE Connection to telephone company-provided COIN service (Central Office ImplemeNted systems) is prohibited. Connection to party line service is subject to state tariffs.

The COM300 is designed to be used on standard device telephone lines. The COM300 connects to the telephone line by means of a USOC RJ11C jack (standard modular telephone jack).

Connect the cable from the telephone RJ11C jack to the modem as shown in Figure 2. If the telephone company has not installed surge protection in the telephone line (no RJ11C jack), one must install surge protection (Model 6362 or 2372-01) and connect the ring and tip terminal blocks as shown in Figure 3.

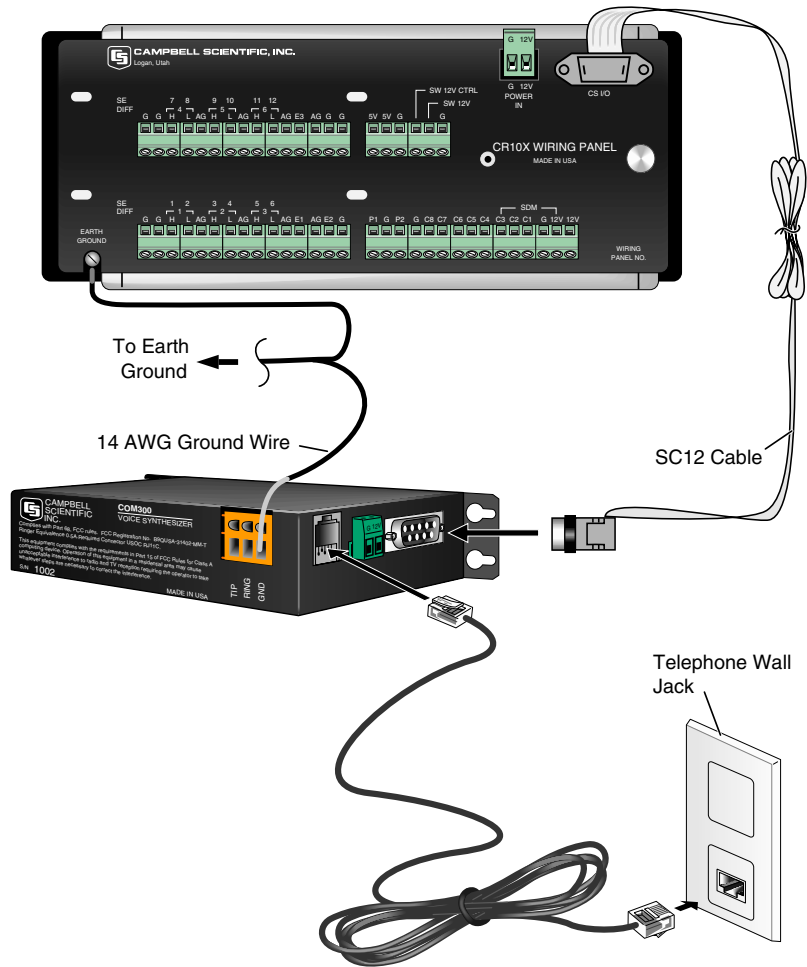

FIGURE 2. COM300 Hardware Connection Using Standard RJ11 Telephone Jack

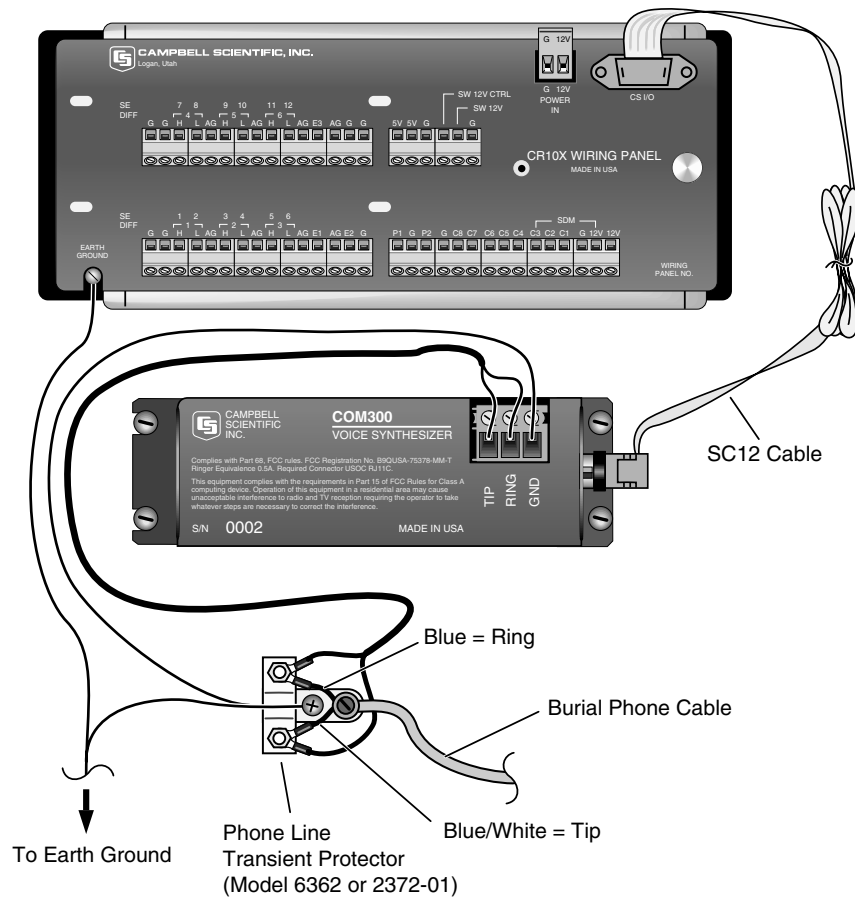

FIGURE 3. COM300 Hardware Connection to CR10X Using Surge Protection Device (No Standard RJ11 Connection Available)

3.2 Properly Grounding the COM300 System

Connect the green 14 awg grounding wire (provided with the COM300) to the grounding terminal (GND) on the COM300 and to the enclosure’s earth ground connection. If the site does not have a grounded enclosure, connect the ground wire directly to an earth ground connection. The datalogger ground should also be tied to the earth ground.

CAUTION

The modem must be grounded for its transient protection to work.

3.3 Powering the COM300 Modem

More recent Campbell Scientific dataloggers provide 12 VDC power on pin 8 of the CS I/O 9 pin connector. For dataloggers that do not provide 12 VDC on the datalogger's CS I/O 9 pin connector, 12 VDC and ground must be connected via the green power connector on the side of the COM300 (refer to Figure 4). Table 1 lists the Campbell Scientific dataloggers that require direct 12 VDC connection to the COM300.

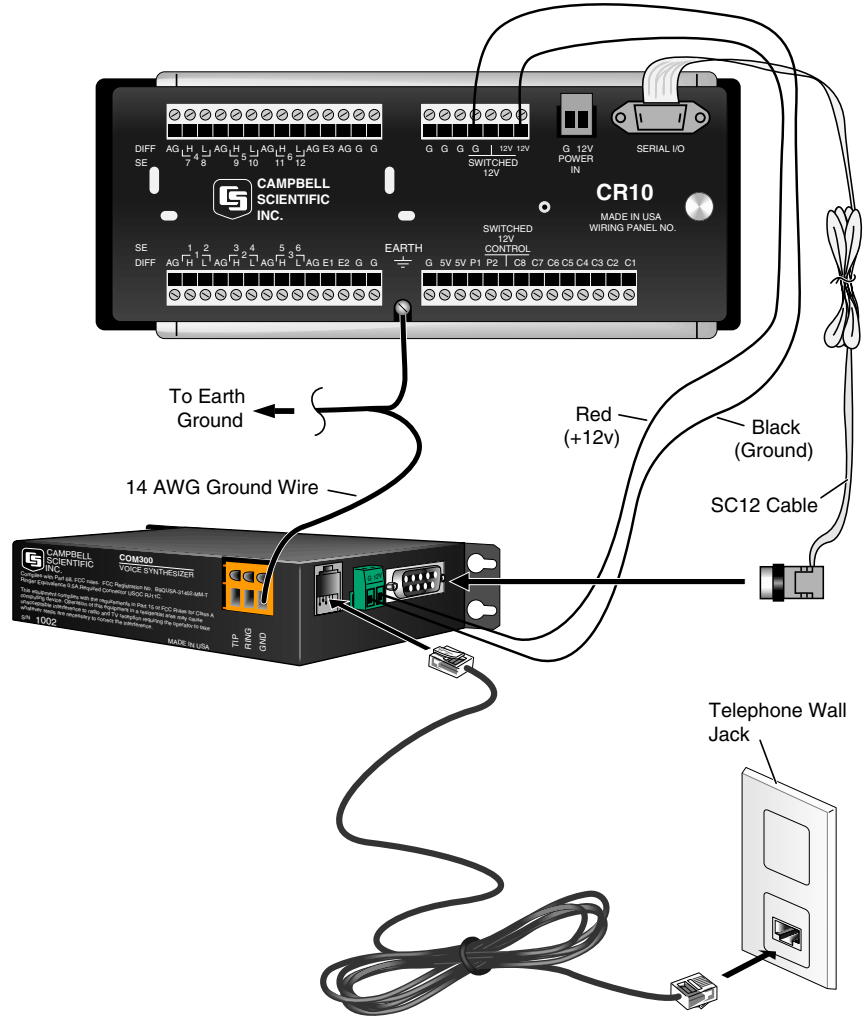

FIGURE 4. Providing Alternate Power to the COM300

TABLE 1. Dataloggers that Require Direct 12 VDC Connection to COM300
CR10(X) w/ silver wiring panel
CR10(X) w/ black CR10 wiring panel (P/N 8032)
CR500—serial number 1764 or lower

3.4 Telephone Service

The goal of the telephone company is to provide you with the best service it can. In order to do this, it may occasionally be necessary for them to make changes in their equipment, operations, or procedures. If you have any questions about your telephone line, such as how many pieces of equipment you can connect to it, the telephone company will provide this information upon request. If the telephone company requests information concerning the equipment which you have connected to your telephone line, the FCC registration number and the ringer equivalence number (REN) of the COM300

are listed on its label. Additional technical information from the FCC and IC on the COM300 is available in Appendix D and E, respectively.

If any of your telephone equipment is not operating properly, you should remove it immediately from your telephone line, as it may cause harm to the telephone network. If the telephone company notes a problem, they may temporarily discontinue service. When practical, they will notify you in advance of this disconnection. If advance notice is not feasible, you will be notified as soon as possible. When you are notified, you will be given the opportunity to correct the problem and informed of your right to file a complaint with the FCC.

3.5 Repairs

To comply with FCC Rules and Regulations, all repairs on the COM300 must be performed by Campbell Scientific, Inc. or an authorized agent of Campbell Scientific, Inc.

4. LoggerTalk Software Installation

LoggerTalk Voice Programming software is provided with the COM300. This software is used to edit datalogger program files (*.DLD) to include code that activates voice communication in voice capable dataloggers.

LoggerTalk requires a computer running Windows 95, Windows NT, or Windows 98 with a 3.5" floppy drive. Before beginning installation, close all active programs including virus and mail applications. To install LoggerTalk, insert disk 1 into your floppy drive. From the Windows Start Menu, choose Run. In the dialog box that appears, type in A:\Setup (this assumes A: is the drive letter assigned to your floppy drive). The installation program will guide you through the remainder of the setup.

NOTE

If an error occurs at the beginning of installation, check your Windows temp directory. (This is typically C:\Temp or C:\Windows\Temp. If you are unsure, go to an MS-DOS prompt and type SET. Look for a line that displays TEMP = and note the directory name.) Move all files to a different directory. This directory is used during software installation. The TEMP directory has a file limit that, if close to being exceeded, will prevent installation of the software.

Operation of LoggerTalk is not covered in this manual. LoggerTalk has an extensive help system that can be accessed at any time by pressing the F1 key, or by selecting the Help menu item from the main window and by pressing the Help button on screens that have it. Two tutorials are included: a basic tutorial that walks you through creating voice strings, downloading the modified program to the datalogger, and navigating through the voice modem menus, and a more advanced tutorial for setting up voice callback. Example program files are included for use in the tutorials. If you do not have prior experience in editing datalogger program files with a Campbell Scientific editor, we suggest that you begin with the basic tutorial and peruse the help system for any questions you might have.

Appendix F of this manual provides a guide to interpreting the code that is added to the end of the datalogger program file for voice communication.

5. Using the COM300 for Standard Modem Communications in PC208W

The COM300 can be used for standard data transmission in PC208W. To establish data communication with the COM300, the dialing string (phone number) must be modified in PC208W to disable voice communication for the duration of that connection (the dialing string is found on the Hardware Tab of PC208W's Setup window).

To disable voice communication, insert three commas and "9" at the end of the dialing string for your datalogger. For example, if the telephone number for your datalogger is "555-4321" you would need to make the following additions: "555-4321,,,9". Each of the three commas inserts a 2 second delay. The 9 disables voice communication. Depending upon the length of time required to establish connection with the modem, you may need to add more commas.

For information on downloading a datalogger program to the COM300, refer to the Basic Tutorial in LoggerTalk's on-line help system.

6. Additional Features

6.1 Security

A security code can be used with the COM300 to prevent users from accessing information beyond the initial messages. If security is not enabled, callers will have access to all input location data, and can change the status of datalogger ports and flags. Security is enabled by editing the datalogger program file in LoggerTalk. Refer to the LoggerTalk on-line help system for further information. If you forget the security code you can open the datalogger program in LoggerTalk and review what number you originally entered.

NOTE

This security code is different than the security code that can be entered to prevent access to certain datalogger functions. Refer to your datalogger operators manual for more information.

6.2 Commercial Mode

When in Commercial Mode, the datalogger will announce the initial messages up to two times and then terminate the connection with the caller. A modem security code must always be entered in the LoggerTalk software when Commercial Mode is used.

6.3 Renaming Menu Strings for Input Location, Ports, and Flags

When you call the datalogger, after the initial messages are announced you are prompted to hear the status of *Input Locations*, *Ports*, or *Flags*. These three

terms can be renamed to something more descriptive using LoggerTalk. A dialog box to make these changes is invoked by selecting the **Menu Strings** button from the main LoggerTalk window. Refer to the LoggerTalk on-line help system for more information.

6.4 Using the COM300 to Hear Final Storage Data

Output data is normally stored in the datalogger's ring memory (Final Storage). The COM300 can access data in input locations only; it cannot access Final Storage data. In order to hear Final Storage data, it must be redirected to an input location. This input location can then be accessed by the COM300. Datalogger Instruction 80 is used to redirect output data to input locations. Refer to the datalogger's operators manual for more information on this instruction, and to Appendix G for an example program using P80.

7. Callback - Datalogger Initiated Calls

The datalogger can be programmed to initiate a call to one or more telephone numbers when a specific condition is met. Typical use of this feature is for the datalogger to call a computer running PC208W and transfer Final Storage data to the computer. However, this feature can also be used with voice communication. When callback is initiated, the datalogger will call the defined telephone number(s) and a message will be announced. This is particularly useful in alerting those monitoring the datalogger system of alarm conditions. LoggerTalk's on-line help system includes a tutorial to guide you through setting up a datalogger initiated voice callback. The datalogger's operators manual also includes general information on the callback feature.

You can intermix voice and modem calls in the same program. Make sure you are not using the same flag for a voice and a modem call.

8. Troubleshooting

8.1 For Problems Encountered When Making Voice Calls

- 1) Can you attach a normal analog telephone to the line and make a call out? If not, contact your local telephone company. If you can make a call out but the connection is poor or faint, contact your local telephone company.
- 2) Verify the COM300 is receiving 12 VDC. If the COM300 is receiving 12 VDC from a separate power supply instead of the datalogger, is the ground of the separate power supply connected to the datalogger's ground?
- 3) Verify the COM300 is the only Modem Enable device connected to the datalogger. Other common Campbell Scientific modem enable devices are the SC32A, some RF modems, and the MD9.
- 4) Verify the datalogger is turned on.
- 5) Verify the datalogger has power on its 5 V output.

8.2 For Problems Encountered When Making Data Calls

- 1) Verify you have selected the correct calling modem from PC208W's setup screen.
- 2) Verify the COM port you are using is activated. As a power saving feature, some notebook computers do not automatically activate the COM ports.
- 3) Verify nothing else is using the same COM port on the computer. Even if a program is minimized in Windows, it may have a lock on the COM port.
- 4) PC208W, Campbell Scientific's communication software, has a log level I/O log that will display an activity of communication as the link is being established. Assuming the above items are O.K., the software log should display something such as "ATDT#####". Where the ##### is the telephone number listed in the dialing path of the software for the datalogger you are trying to call. As you are connected to each device in the communications link, this will be reflected in the activity screen. This may help to pinpoint which device in the communications link is failing.

To comply with FCC Rules and Regulations, all repairs on the COM300 modem **must** be performed by Campbell Scientific, Inc. or an authorized agent of Campbell Scientific, Inc. For assistance in installation, troubleshooting, or for repair, contact Campbell Scientific:

Campbell Scientific, Inc.,
815 West 1800 North
Logan, Utah 84321-1784
Telephone: (435) 753-2342
Fax: (435) 750-9540
Web site: <http://www.campbellsci.com/support.htm>

TABLE A-1. Pin Description			
<p>ABR = Abbreviation for the function name. PIN = Pin number. O = Signal Out of the datalogger to a peripheral. I = Signal Into the datalogger from a peripheral.</p>			
PIN	ABR	I/O	Description
1	5V	I	5 VDC supply. Not used.
2	SG		Signal Ground: Provides a power return for pin 1 (5V), and is used as a reference for voltage levels.
3	RING	O	Ring: Raised by the modem to put the datalogger in the telecommunications mode.
4	RXD	O	Receive Data: Serial data transmitted by the modem are transmitted on pin 4.
5	ME	I	Modem Enable: A logic high internally switches power to the modem. A logic low internally powers down the modem.
6	SDE	I	Synchronous Device Enable: A logic high disables communication with the modem, without removing power or changing the modem's mode.
7	Clock/ HS	I/O	Clock/Handshake: Used with the SDE and TXD lines to communicate with devices that address it.
8	TE	I	+12 VDC power supply.
9	TXD	I	Transmit Data: Serial data are transmitted from the datalogger to the modem on pin 9; logic low marking (0V) logic high spacing (5V) standard asynchronous ASCII, 8 data bits, no parity, 1 start bit, 1 stop bit, 300, 1200, 9600, 76,800 baud (user selectable).

Appendix B. Theory of Operation

B.1 Theory of Operation

The COM300 modem is used to transmit data over bandwidth-limited channels such as telephone lines by modulating audio tones, using Phase Shift Keying (PSK) at 9600 or 1200 baud and Frequency Shift Keying (FSK) at 300 baud.

The telephone company gives a 40 to 150 VRMS, 20 Hz signal on the telephone lines to signify a ring, which is typically on for 2 seconds and off for 4 seconds. The ring detection circuitry is continuously powered but draws less than 2 μ A. The ring signal is passed on to the datalogger through an opto-coupler. The datalogger responds by addressing the modem synchronously (pins 6 and 7) which switches on the 5 VDC power to the modem. The modem then answers and remains off-hook until it loses the carrier or the datalogger addresses a shut down command to the modem. The datalogger sends the shut down command either in response to an external command or after 40 seconds elapse without a command. The shut down command switches off the 5 VDC power to the modem, dropping power to the off-hook relay and thus placing the telephone line on-hook.

To reject noise common to both telephone lines and to satisfy registration requirements, the modem circuitry is electrically isolated from the telephone lines by using an opto-isolator and coupling transformer.

Appendix C. Changing RAM or PROM Chips in the CR10

The CR10 has two sockets for Random Access Memory (RAM) and one socket for Programmable Read Only Memory (PROM). The standard CR10 has 64K of RAM, (a 32K RAM chip in each socket). Earlier CR10s had 16K of RAM (an 8K RAM chip in each socket).

C.1 Disassembling the CR10

The sockets provided for RAM and PROM are located on the CR10 CPU circuit card inside the CR10 can. To expose the RAM and PROM sockets, remove the two Phillips head screws from the end opposite the connectors. Remove the end cap. The ends of two circuit cards and the RF shield will be visible (see Figure C-1). Now lay the CR10 on a flat surface, (i.e., a table), and push on the RF shield with your thumbs while grasping the can with your hands. Remove the circuit cards from the can. Orient the cards with the connector on the left and with the card that matches Figure C-2 component-side up. The Central Processing Unit (CPU) is found at location H-9 and the three slots for RAM and PROM will be directly beneath it.

C.2 Installing New RAM Chips in CR10 with 16K RAM

The two 8K RAM chips are found at locations C11 and C14. With a small flat screw driver gently pry out the two 8K RAM chips at these locations and replace them with the 32K RAM chips provided in the memory upgrade. The new chips should be installed so the notched end is towards the nearest card edge. Before pushing the chips into the socket make certain that all the pins are correctly seated. After installing the 32K chips, check for pins that may be bent or not firmly seated in the socket. If you notice a bent pin, remove the chip, carefully straighten it and repeat the installation procedure.

C.2.1 Changing Jumpers

There are six jumpers used to configure hardware for different RAM sizes. Figure C-2 shows the location of the jumpers and a magnified view of the jumper settings for different memory configurations. A pin or small screw driver tip will work best for pulling these jumpers and relocating them.

C.2.2 RAM Test

Attach the CR10KD Keyboard/Display and apply power to the CR10. After the CR10 executes the RAM/PROM self test, the number 96 should be displayed in the window. The number is the sum of Kbytes in RAM (64) plus the number of Kbytes in ROM (32).

C.3 Installing New PROM

The PROM chip is found at location C8 on the CR10 CPU board, (see Figure C-2). With a small flat screw driver, gently pry out the PROM chip and replace it with the new one. The new chip should be installed so that the notched end is towards the nearest card edge. Before pushing the chip into the socket make certain that all the pins are seating correctly. After installing the chip, check for pins that may be bent or not making contact. If you notice a bent pin, remove the chip, carefully straighten it and repeat the installation procedure.

To make certain that the new chip is installed correctly enter the CR10 *B mode (Section 1.6 in the CR10 Operator's Manual) and advance to the second window. This window displays the PROM signature. The five digit number in the window should match the PROM signature given with the new PROM documentation. If the numbers are different, disassemble the CR10 and look for pins that are bent or not firmly seated.

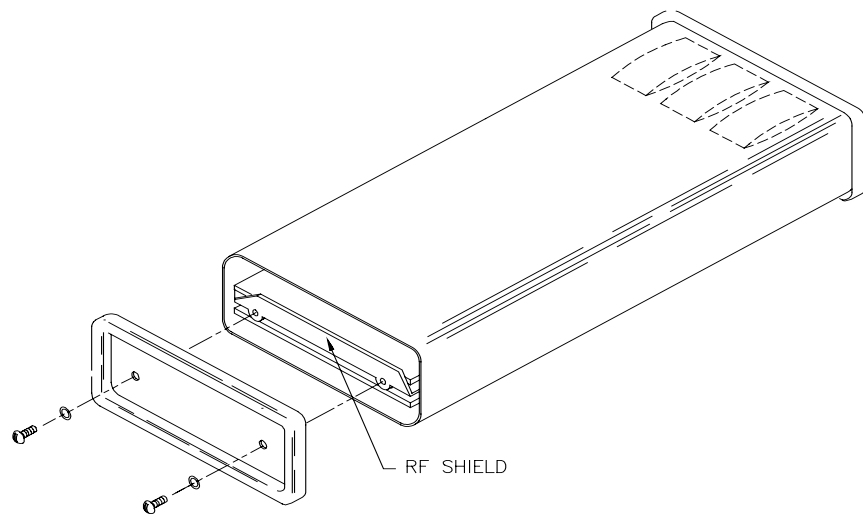

FIGURE C-1. Disassembling CR10

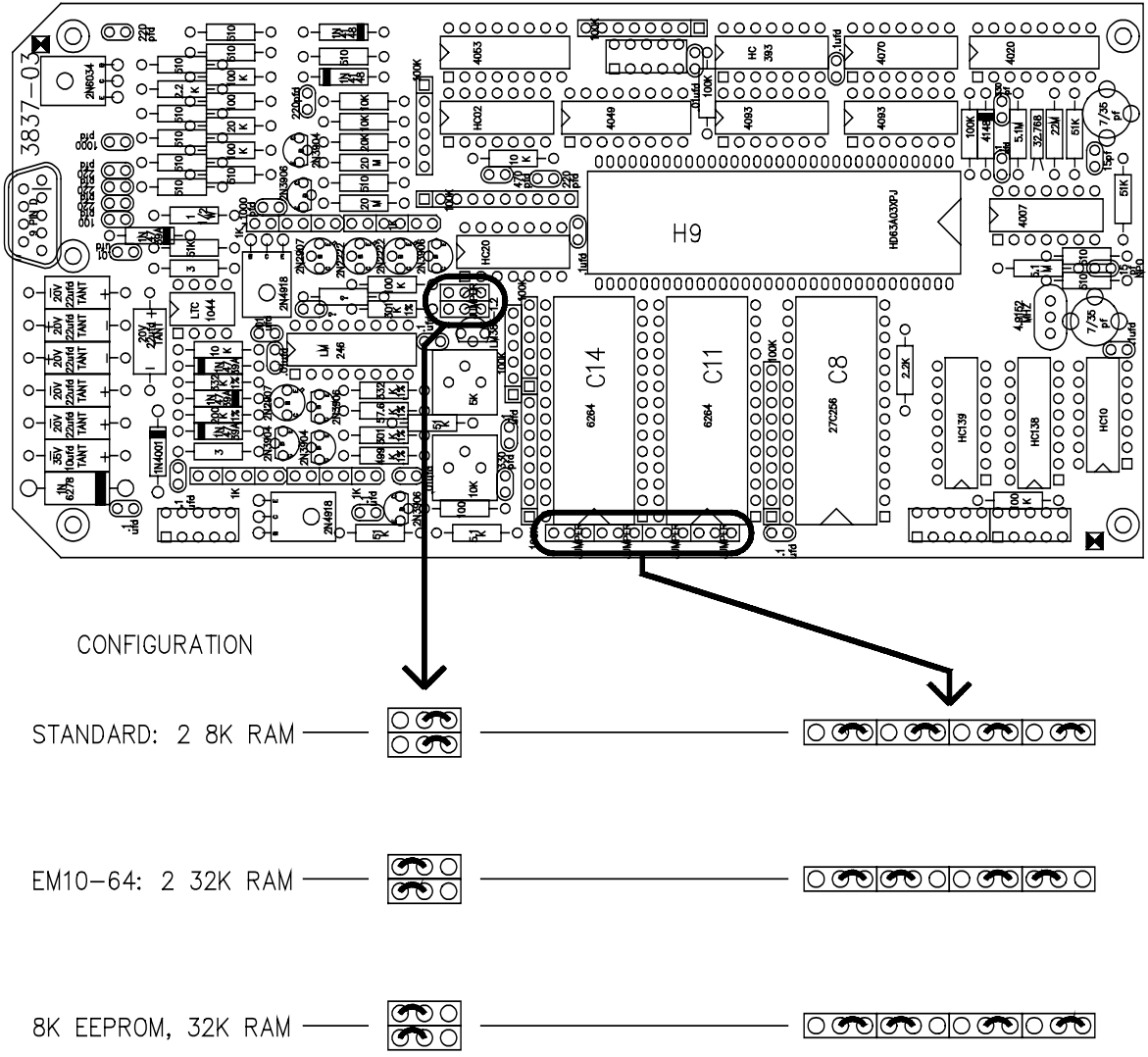

FIGURE C-2. Jumper Settings for Different RAM Configurations

Appendix D. FCC Warning to Users of Class A Computing Devices

WARNING

This equipment generates, uses, and can radiate radio frequency energy, and if not installed and used in accordance with the instruction manual, may cause interference to radio communications. It has been tested and found to comply with the limits for a Class A computing device pursuant to Subpart J of Part 15 of FCC Rules, which are designed to provide reasonable protection against such interference when operated in a COMMERCIAL ENVIRONMENT. Operation of this equipment in a residential area may cause interference to radio and television reception. The operator must take whatever measures are necessary to correct the interference.

The REN is used to determine the quantity of devices which may be connected to the telephone line. Excessive REN's on the telephone line may result in the devices not ringing in response to an incoming call. In most, but not all areas, the sum of the REN's should not exceed five (5.0). To be certain of the number of devices that may be connected to the line, as determined by the total REN's, contact the telephone company to determine the maximum REN for the calling area.

This equipment cannot be used on the telephone company-provided coin service. Connection to Party Line Service is subject to State Tariffs.

If this equipment cannot be used on the telephone network, the telephone company will notify you in advance that temporary discontinuance of service may be required. If advance notice isn't practical, the telephone company will notify the customer as soon as possible. Also, you will be advised of your right to file a complaint with the FCC if you believe it is necessary.

Appendix E. IC Information

NOTE

Industry Canada (IC) was formally known as DOC.

CP-01, Issue 8, Part I Section 14.1

“NOTICE: The Industry Canada label identifies certified equipment. This certification means that the equipment meets certain telecommunications network protective, operational and safety requirements as prescribed in the appropriate Terminal Equipment Technical Requirements document(s). The Department does not guarantee the equipment will operate to the user’s satisfaction.

“Before installing this equipment, users should ensure that it is permissible to be connected to the facilities of the local telecommunications company. The equipment must also be installed using an acceptable method of connection. The customer should be aware that compliance with the above conditions may not prevent degradation of service in some situations.

“Repairs to certified equipment should be coordinated by a representative designated by the supplier. Any repairs or alterations made by the user to this equipment, or equipment malfunctions, may give the telecommunications company cause to request the user to disconnect the equipment.

“Users should ensure for their own protection that the electrical ground connections of the power utility, telephone lines and internal metallic water pipe system, if present, are connected together. This precaution may be particularly important in rural areas.

CAUTION

Users should not attempt to make such connections themselves, but should contact the appropriate electric inspection authority, or electrician, as appropriate.”

CP-01, Issue 8, Part I Section 14.2

“NOTICE: The Ringer Equivalence Number (REN) assigned to each terminal device provides an indication of the maximum number of terminals allowed to be connected to a telephone interface. The termination on an interface may consist of any combination of devices subject only to the requirement that the sum of the Ringer Equivalence Numbers of all the devices does not exceed 5.”

Appendix F. Reading Voice Code Information from a *.DLD File

When a file is edited and saved in LoggerTalk, the information for voice communication is added to the end of the *.DLD file. This information can be verified for accuracy.

A copy of typical voice code is provided below. The numbers between the "smiley faces" (☺) and the "&" symbols are the numbers associated with the words used from the word list. The ☺ symbol is equivalent to control code A (^A). Refer to Appendix H to review the word list used with the COM300.

Several lines of code that begin with a tilde (~) may precede the voice code. These strings are set up information. The voice code follows this information. The first line of the voice code is the wording used for input locations. The second line is the wording used for ports. The third line is the wording used for flags. The lines following are used for message descriptions. Each message will terminate with a period.

Notice that line four below starts with ">\4". The > indicates the string is an initial message. The 4 following the slash indicates the number of digits following the decimal point that the COM300 will announce for that input location.

The numbers inside the quotation marks are the words associated with the input location.

The number following the "\$" symbol is the input memory location number used in the datalogger.

F.1 Typical Voice Code

Following is code for a typical call:

```
;|#"☺56&☺57&"#  
#"☺53&"#  
#"☺52&"#  
>\4☺88&☺89&☺109&☺74&☺71&☺71&☺71&"☺109&☺135&☺86&"  
☺85&$3☺87&☺122&\  
\4"☺109&☺98&☺191&"☺85&$1☺192&\  
|  
♣♣
```

The above code translates to:

Input Locations

Ports

Flags

(four decimal places) Campbell Scientific Datalogger Program (pause)
(pause) (pause) "Datalogger Internal Temperature" is (input location 3)
Degrees Fahrenheit.

(four decimal places) Datalogger Battery Voltage is (input location 1) Volts.

F.2 Callback Code

If the datalogger has been programmed to initiate voice calls, you will see the phone number associated with the call command at the very end of the listing. The flag number used to initiate the call and the phone number will be between "at" symbols (@).

This example initiates a voice call:

```
;|#"Ⓢ56&Ⓢ57&"#  
#"Ⓢ53&"#  
#"Ⓢ52&"#  
><2\4"Ⓢ98&Ⓢ191&"Ⓢ85&$1Ⓢ192&.\  
@2555-1234@  
|  
♣♣
```

Line four, above, starts out as "><2/4". The ">" means this message is selected as an initial message. The "<2" indicates that this message will be spoken if flag 2 is the flag that initiates callback. The "2" preceding the phone number "@2555-1234@" means the phone number (555-1234) will be called when flag 2 goes low in the program.

The code translates as:

Input Locations

Ports

Flags

(flag 2) (4 decimal places) "Battery Voltage" Is (input location 1) Volts.

(callback flag 2) (telephone number 555-1234)

F.3 Security Enabled

This last example uses the security code "1234" to allow access to the second level menu. Notice the characters following the "?" at the beginning of the character stream. The security code will always be the very first thing in the imbedded character portion of the *.DLD file.

```
;|?1234#"Ⓢ56&Ⓢ57&"#
```

```
#"Ⓢ53&"#
```

```
#"Ⓢ52&"#
```

```
>\4Ⓢ88&Ⓢ89&Ⓢ109&Ⓢ74&Ⓢ71&Ⓢ71&Ⓢ71&"Ⓢ109&Ⓢ135&Ⓢ86&"  
Ⓢ85&$3Ⓢ87&Ⓢ122&.\
```

```
\4"Ⓢ109&Ⓢ98&Ⓢ191&"Ⓢ85&$1Ⓢ192&.\
```

This code translates to:

(security code 1234) Input Locations

Ports

Flags

(4 decimal places) Campbell Scientific Datalogger Program (pause)
(pause) (pause) "Datalogger Internal Temperature" Is (input location 3)
Degrees Fahrenheit.

(4 decimal places) "Datalogger Battery Voltage" Is (input location 1)
Volts.

Appendix G. Using P80 to Redirect Final Storage Data to Input Locations

The following section of code provides an example of using datalogger Instruction 80 to redirect Final Storage data to input locations. *This is not a complete program.* Instructions would be included prior to this section of code to measure sensors, perform control functions, and provide initial data processing. All text entries preceded by a semicolon (;) are comments inserted by the programmer to explain the instructions.

```
;The following section of code uses  
;program instruction 80 to redirect  
;data from final storage to input locations  
  
32: If time is (P92)  
01: 0000 minutes into a  
02: 60 minute interval  
03: 10 Set high Flag 0 ; output data  
  
33: Set Active Storage Area (P80)  
01: 3 Input Storage Area ; parameter 3 directs data to input storage  
02: 5 Array ID or location ; starting at location 5  
  
34: Maximize (P73)  
01: 1 Rep  
02: 11 Value with Hr-Min-Sec  
03: 4 Loc AIR TEMPC
```

Every sixty minutes the maximum air temperature will be stored in location #5. No output data will be sent to Final Storage.

Instruction 80 should follow the instruction setting Flag 0, and should precede the output instructions. Keep in mind that all output processing instructions following Instruction 80 will be redirected to input storage until another Instruction 80 is used or until the program table is executed again (output defaults to Final Storage Area 1 at the beginning of the program table).

Appendix H. COM300 Word List

H.1 COM300 Word List - Numerical Order

1. ZERO	49. STATUS	97. BAROMETRIC
2. ONE	50. HIGH	98. BARS
3. TWO	51. LOW	99. BATTERY
4. THREE	52. TOGGLE	100. CALIBRATE
5. FOUR	53. FLAGS	101. CELSIUS
6. FIVE	54. PORTS	102. CENTI
7. SIX	55. THRU	103. CHILL
8. SEVEN	56. PORT	104. CLOSED
9. EIGHT	57. INPUT	105. CONDUCTIVITY
10. NINE	58. LOCATIONS	106. CUBIC
11. TEN	59. FLAG	107. CURRENT
12. ELEVEN	60. AND	108. DAM
13. TWELVE	61. OF	109. DATA
14. THIRTEEN	62. SECURITY	110. DATALOGGER
15. FOURTEEN	63. CODE	111. DAY
16. FIFTEEN	64. YOUR	112. DEPTH
17. SIXTEEN	65. POINT	113. DEVIATION
18. SEVENTEEN	66. PLEASE	114. DIRECTION
19. EIGHTEEN	67. BY	115. D-O
20. NINETEEN	68. MINUS	116. DOWN
21. TWENTY	69. ENTER	117. DRAW
22. THIRTY	70. SELECTION	118. EQUAL
23. FORTY	71. GOODBYE	119. E-T-O
24. FIFTY	72. 50MS	120. EVENT
25. SIXTY	73. MESSAGE	121. EXTERNAL
26. SEVENTY	74. CALLBACK	122. EXCEEDS
27. EIGHTY	75. PROGRAM	123. FAHRENHEIT
28. NINETY	76. SIGNATURE	124. FALL
29. HUNDRED	77. EPROM	125. FEET
30. THOUSAND	78. KILOBYTES	126. FLOW
31. MILLION	79. MEMORY	127. FROM
32. PRESS	80. NUMBER	128. GALLONS
33. POUND	81. E08'S	129. GRAM
34. DEW	82. TABLE	130. HELLO
35. HEAR	83. OVERRUNS	131. SET
36. MENU	84. VERSION	132. HOUR
37. AGAIN	85. REVISION	133. HUMIDITY
38. STAR	86. IS	134. IN
39. DISCONNECT	87. TEMPERATURE	135. INCHES
40. YOU	88. DEGREES	136. INTERNAL
41. THE	89. CAMPBELL	137. KILO
42. HAVE	90. SCIENTIFIC	138. LAST
43. SELECTED	91. ACRE	139. LEVEL
44. MONITOR	92. AIR	140. LITER
45. KEY	93. ALARM	141. RESET
46. FOLLOWING	94. ARE	
47. RETURN	95. AT	
48. PREVIOUS	96. AVERAGE	

142. MAXIMUM	197. WEATHER	252. EAST
143. MERCURY	198. WELL	253. EASTERN
144. METER	199. WIND	254. EFFLUENT
145. METERS	200. A	255. ELECTRON
146. MICRO	201. A-M	256. ELEVATION
147. MILES	202. ABOVE	257. EMPTIED
148. MILLI	203. ACCUMULATE	258. ENGINE
149. MINIMUM	204. ACKNOWLEDGE	259. ERROR
150. MINUTE	205. ADDITION	260. F
151. MOISTURE	206. ADDITIONAL	261. FAILED
152. MONTH	207. AGO	262. FAILURE
153. MULTIPLIER	208. ALL	263. FALLING
154. NEW	209. AMMONIUM	264. FIRST
155. N-T-U	210. APPROACH	265. FLUORIDE
156. OFF	211. AREA	266. FREEZER
157. OFFSET	212. AVAILABLE	267. FREQUENCY
158. ON	213. B	268. FRIDAY
159. OPEN	214. BACK-UP	269. FUEL
160. OVERFLOW	215. BAY	270. G
161. PARTS	216. BE	271. GAS
162. PER	217. BEAVER	272. GATE
163. PERCENT	218. BEDS	273. GAUGE
164. P-H	219. BEHIND	274. GENERATOR
165. PRECIPITATION	220. BELOW	275. GOING
166. PRESSURE	221. BIG	276. GOOD
167. PROGRESS	222. BILLION	277. GRADIENT
168. P-S-I	223. BLAST	278. GRASS
169. RADIATION	224. BOILER	279. GROUND
170. RAIN	225. BUILDING	280. H
171. RATE	226. C	281. H-2-S
172. REFERENCE	227. C-O	282. HAD
173. RELATIVE	228. CALCIUM	283. HARDNESS
174. R-P-M	229. CALL	284. HAS
175. SAMPLE	230. CALLS	285. HASH
176. SECOND	231. CAN	286. HEAD
177. SECONDS	232. CEMENT	287. HEAT
178. SIEMENS	233. CENTRAL	288. HERTZ
179. SITE	234. CHECK	289. HOLD
180. SNOW	235. CHILLER	290. HOT
181. SOIL	236. CHLORIDE	291. HOURS
182. SOLAR	237. CHLORINE	292. HYDROLOGIC
183. SPEED	238. CONTACT	293. I
184. SQUARED	239. CORRECTED	294. INDEX
185. STAGE	240. CROSSING	295. ING
186. STANDARD	241. CYCLES	296. INTAKE
187. STATION	242. D	297. INTRUDER
188. STORM	243. DAYS	298. IRRADIANT
189. TIME	244. DELTA	299. IRRIGATION
190. TURBIDITY	245. DING	300. IT
191. VELOCITY	246. DISTRICT	301. J
192. VOLTAGE	247. DIVERSION	302. K
193. VOLTS	248. DOCK	303. KNOTS
194. WARNING	249. DOOR	
195. WATER	250. DURING	
196. WATTS	251. E	

304. L	359. R	414. UNITS
305. LAKE	360. RACE	415. UP
306. LAYER	361. RADIAL	416. V
307. LINE	362. RANGE	417. V-O-C
308. LOAD	363. REACHED	418. VALUE
309. LOCATED	364. READING	419. VERTICAL
310. LOCATION	365. RECEIVED	420. VIA
311. LOGAN	366. RESERVOIR	421. W
312. M	367. RESIDUAL	422. WAS
313. M-R-P	368. RISING	423. WE
314. MANAGEMENT	369. RIVER	424. WEDNESDAY
315. MENDON	370. ROAD	425. WELCOME
316. MID	371. ROOM	426. WEST
317. MID-MOUNTAIN	372. RUN	427. WHAT
318. MIDNIGHT	373. RUNOFF	428. WITH
319. MINUTES	374. S	429. X
320. MODEM	375. S-O-2	430. Y
321. MONDAY	376. SATURDAY	431. YEAR
322. MOUNT	377. SEDIMENT	432. YESTERDAY
323. MOUNTAIN	378. SENSOR	433. Z
324. N	379. SENSORS	
325. NEEDS	380. SHAFT	
326. NETWORK	381. SINCE	
327. NEXT	382. SKIING	
328. NITRATE	383. SMOG	
329. NITROGEN	384. SODIUM	
330. NO	385. SONAR	
331. NOON	386. SOUTH	
332. NORTH	387. SPILL	
333. NOT	388. STATES	
334. O	389. STREAMBED	
335. OK	390. SUMMIT	
336. OR	391. SUMP	
337. OUT	392. SUNBURN	
338. OZONE	393. SUNDAY	
339. P	394. SURFACE	
340. P-M	395. SURFACTANCE	
341. PACIFIC	396. SYSTEM	
342. PARAMETER	397. T	
343. PAST	398. TAIL	
344. PEAK	399. TESTING	
345. PENDING	400. THANK	
346. PHONE	401. THAT	
347. PLANT	402. THIS	
348. POND	403. THRESHOLD	
349. POTASSIUM	404. THURSDAY	
350. POWDER	405. TING	
351. POWER	406. TO	
352. PREHEAT	407. TODAY	
353. PROBE	408. TODAYS	
354. PRODUCT	409. TOTAL	
355. PUMP	410. TRIGGERED	
356. Q	411. TUESDAY	
357. QUALITY	412. U	
358. QUIT	413. ULTRAVIOLET	

H.2 COM300 Word List - Alphabetical Order

71. 50MS	233. CHECK	117. EQUAL
199. A	102. CHILL	258. ERROR
200. A-M	234. CHILLER	119. EVENT
201. ABOVE	235. CHLORIDE	121. EXCEEDS
202. ACCUMULATE	236. CHLORINE	120. EXTERNAL
203. ACKNOWLEDGE	103. CLOSED	259. F
90. ACRE	62. CODE	122. FAHRENHEIT
204. ADDITION	104. CONDUCTIVITY	260. FAILED
205. ADDITIONAL	237. CONTACT	261. FAILURE
36. AGAIN	238. CORRECTED	123. FALL
206. AGO	239. CROSSING	262. FALLING
91. AIR	105. CUBIC	124. FEET
92. ALARM	106. CURRENT	15. FIFTEEN
207. ALL	240. CYCLES	23. FIFTY
208. AMMONIUM	241. D	263. FIRST
59. AND	114. D-O	5. FIVE
209. APPROACH	107. DAM	58. FLAG
93. ARE	108. DATA	52. FLAGS
210. AREA	109. DATALOGGER	125. FLOW
94. AT	110. DAY	264. FLUORIDE
211. AVAILABLE	242. DAYS	45. FOLLOWING
95. AVERAGE	87. DEGREES	22. FORTY
212. B	243. DELTA	4. FOUR
213. BACK-UP	111. DEPTH	14. FOURTEEN
96. BAROMETRIC	112. DEVIATION	265. FREEZER
97. BARS	33. DEW	266. FREQUENCY
98. BATTERY	244. DING	267. FRIDAY
214. BAY	113. DIRECTION	126. FROM
215. BE	38. DISCONNECT	268. FUEL
216. BEAVER	245. DISTRICT	269. G
217. BEDS	246. DIVERSION	127. GALLONS
218. BEHIND	247. DOCK	270. GAS
219. BELOW	248. DOOR	271. GATE
220. BIG	115. DOWN	272. GAUGE
221. BILLION	116. DRAW	273. GENERATOR
222. BLAST	249. DURING	274. GOING
223. BOILER	250. E	275. GOOD
224. BUILDING	118. E-T-O	70. GOODBYE
66. BY	80. E08'S	276. GRADIENT
225. C	251. EAST	128. GRAM
226. C-O	252. EASTERN	277. GRASS
227. CALCIUM	253. EFFLUENT	278. GROUND
99. CALIBRATE	8. EIGHT	279. H
228. CALL	18. EIGHTEEN	280. H-2-S
73. CALLBACK	26. EIGHTY	281. HAD
229. CALLS	254. ELECTRON	282. HARDNESS
88. CAMPBELL	255. ELEVATION	283. HAS
230. CAN	11. ELEVEN	284. HASH
100. CELSIUS	256. EMPTIED	41. HAVE
231. CEMENT	257. ENGINE	
101. CENTI	68. ENTER	
232. CENTRAL	76. EPROM	

285. HEAD	144. METERS	160. PARTS
34. HEAR	145. MICRO	342. PAST
286. HEAT	315. MID	343. PEAK
129. HELLO	316. MID-MOUNTAIN	344. PENDING
287. HERTZ	317. MIDNIGHT	161. PER
49. HIGH	146. MILES	162. PERCENT
288. HOLD	147. MILLI	345. PHONE
289. HOT	30. MILLION	346. PLANT
131. HOUR	148. MINIMUM	65. PLEASE
290. HOURS	67. MINUS	64. POINT
132. HUMIDITY	149. MINUTE	347. POND
28. HUNDRED	318. MINUTES	55. PORT
291. HYDROLOGIC	319. MODEM	53. PORTS
292. I	150. MOISTURE	348. POTASSIUM
133. IN	320. MONDAY	32. POUND
134. INCHES	43. MONITOR	349. POWDER
293. INDEX	151. MONTH	350. POWER
294. ING	321. MOUNT	164. PRECIPITATION
56. INPUT	322. MOUNTAIN	351. PREHEAT
295. INTAKE	152. MULTIPLIER	31. PRESS
135. INTERNAL	323. N	165. PRESSURE
296. INTRUDER	154. N-T-U	47. PREVIOUS
297. IRRADIANT	324. NEEDS	352. PROBE
298. IRRIGATION	325. NETWORK	353. PRODUCT
85. IS	153. NEW	74. PROGRAM
299. IT	326. NEXT	166. PROGRESS
300. J	9. NINE	354. PUMP
301. K	19. NINETEEN	355. Q
44. KEY	27. NINETY	356. QUALITY
136. KILO	327. NITRATE	357. QUIT
77. KILOBYTES	328. NITROGEN	358. R
302. KNOTS	329. NO	173. R-P-M
303. L	330. NOON	359. RACE
304. LAKE	331. NORTH	360. RADIAL
137. LAST	332. NOT	168. RADIATION
305. LAYER	79. NUMBER	169. RAIN
138. LEVEL	333. O	361. RANGE
306. LINE	60. OF	170. RATE
139. LITER	155. OFF	362. REACHED
307. LOAD	156. OFFSET	363. READING
308. LOCATED	334. OK	364. RECEIVED
309. LOCATION	157. ON	171. REFERENCE
57. LOCATIONS	1. ONE	172. RELATIVE
310. LOGAN	158. OPEN	365. RESERVOIR
50. LOW	335. OR	140. RESET
311. M	336. OUT	366. RESIDUAL
312. M-R-P	159. OVERFLOW	46. RETURN
313. MANAGEMENT	82. OVERRUNS	84. REVISION
141. MAXIMUM	337. OZONE	367. RISING
78. MEMORY	338. P	368. RIVER
314. MENDON	163. P-H	369. ROAD
35. MENU	339. P-M	370. ROOM
142. MERCURY	167. P-S-I	
72. MESSAGE	340. PACIFIC	
143. METER	341. PARAMETER	

371. RUN	397. TAIL	428. X
372. RUNOFF	86. TEMPERATURE	429. Y
373. S	10. TEN	430. YEAR
374. S-O-2	398. TESTING	431. YESTERDAY
174. SAMPLE	399. THANK	39. YOU
375. SATURDAY	400. THAT	63. YOUR
89. SCIENTIFIC	40. THE	432. Z
175. SECOND	13. THIRTEEN	0. ZERO
176. SECONDS	21. THIRTY	
61. SECURITY	401. THIS	
376. SEDIMENT	29. THOUSAND	
42. SELECTED	3. THREE	
69. SELECTION	402. THRESHOLD	
377. SENSOR	54. THRU	
378. SENSORS	403. THURSDAY	
130. SET	188. TIME	
7. SEVEN	404. TING	
17. SEVENTEEN	405. TO	
25. SEVENTY	406. TODAY	
379. SHAFT	407. TODAYS	
177. SIEMENS	51. TOGGLE	
75. SIGNATURE	408. TOTAL	
380. SINCE	409. TRIGGERED	
178. SITE	410. TUESDAY	
6. SIX	189. TURBIDITY	
16. SIXTEEN	12. TWELVE	
24. SIXTY	20. TWENTY	
381. SKIING	2. TWO	
382. SMOG	411. U	
179. SNOW	412. ULTRAVIOLET	
383. SODIUM	413. UNITS	
180. SOIL	414. UP	
181. SOLAR	415. V	
384. SONAR	416. V-O-C	
385. SOUTH	417. VALUE	
182. SPEED	190. VELOCITY	
386. SPILL	83. VERSION	
183. SQUARED	418. VERTICAL	
184. STAGE	419. VIA	
185. STANDARD	191. VOLTAGE	
37. STAR	192. VOLTS	
387. STATES	420. W	
186. STATION	193. WARNING	
48. STATUS	421. WAS	
187. STORM	194. WATER	
388. STREAMBED	195. WATTS	
389. SUMMIT	422. WE	
390. SUMP	196. WEATHER	
391. SUNBURN	423. WEDNESDAY	
392. SUNDAY	424. WELCOME	
393. SURFACE	197. WELL	
394. SURFACTANCE	425. WEST	
395. SYSTEM	426. WHAT	
396. T	198. WIND	
81. TABLE	427. WITH	