

INSTRUCTION MANUAL



CM106 Tripod

Revision: 5/11



Copyright © 2005-2011
Campbell Scientific, Inc.

WARRANTY AND ASSISTANCE

This equipment is warranted by CAMPBELL SCIENTIFIC (CANADA) CORP. ("CSC") to be free from defects in materials and workmanship under normal use and service for **twelve (12) months** from date of shipment unless specified otherwise. **** **Batteries are not warranted.** **** CSC's obligation under this warranty is limited to repairing or replacing (at CSC's option) defective products. The customer shall assume all costs of removing, reinstalling, and shipping defective products to CSC. CSC will return such products by surface carrier prepaid. This warranty shall not apply to any CSC products which have been subjected to modification, misuse, neglect, accidents of nature, or shipping damage. This warranty is in lieu of all other warranties, expressed or implied, including warranties of merchantability or fitness for a particular purpose. CSC is not liable for special, indirect, incidental, or consequential damages.

Products may not be returned without prior authorization. To obtain a Return Merchandise Authorization (RMA), contact CAMPBELL SCIENTIFIC (CANADA) CORP., at (780) 454-2505. An RMA number will be issued in order to facilitate Repair Personnel in identifying an instrument upon arrival. Please write this number clearly on the outside of the shipping container. Include description of symptoms and all pertinent details.

CAMPBELL SCIENTIFIC (CANADA) CORP. does not accept collect calls.

Non-warranty products returned for repair should be accompanied by a purchase order to cover repair costs.



CAMPBELL SCIENTIFIC
C A N A D A C O R P .

11564 - 149 street - edmonton - alberta - T5M 1W7
tel 780.454.2505 fax 780.454.2655

www.campbellsci.ca

PLEASE READ FIRST

About this manual

Please note that this manual was originally produced by Campbell Scientific Inc. (CSI) primarily for the US market. Some spellings, weights and measures may reflect this origin.

Some useful conversion factors:

Area:	1 in ² (square inch) = 645 mm ²
Length:	1 in. (inch) = 25.4 mm 1 ft (foot) = 304.8 mm 1 yard = 0.914 m 1 mile = 1.609 km
Mass:	1 oz. (ounce) = 28.35 g 1 lb (pound weight) = 0.454 kg
Pressure:	1 psi (lb/in ²) = 68.95 mb
Volume:	1 US gallon = 3.785 litres

In addition, part ordering numbers may vary. For example, the CABLE5CBL is a CSI part number and known as a FIN5COND at Campbell Scientific Canada (CSC). CSC Technical Support will be pleased to assist with any questions.

CM106 Table of Contents

PDF viewers note: These page numbers refer to the printed version of this document. Use the Adobe Acrobat® bookmarks tab for links to specific sections.

1. General	1
2. Specifications	2
3. Tools List (for tripod, mast, enclosures, and crossarms)	2
4. Tripod Components	3
5. Tripod Installation	4
5.1 Tripod Base	4
5.1.1 Mounting on a Relatively Flat Area	4
5.1.2 Mounting on an Incline	5
5.2 Mast	6
5.3 Installing the Optional Guy Kit	8
5.4 Staking the Tripod Feet	10
5.5 Tripod Grounding	11
5.6 Crossarm Attachment	13
5.7 Enclosure Attachment	13
5.7.1 Enclosure Mounting to Tripod Mast	13
5.7.2 Enclosure Mounting to Tripod Leg	14
6. Mounting Brackets	16
6.1 CM210 Crossarm Mounting Kit	16
6.2 CM216 Mast Mounting Kit	17
6.3 CM220 Right Angle Mounting Kit	18
6.4 CM225 and 18098 Pyranometer Mounting Stand	19
6.5 CM230 Adjustable Angle Mounting Kit	20
6.6 CM235 Magnetic Mounting Stand	21
6.7 RM Young Gill Radiation Shields	22

List of Figures

1-1. CM106 Tripod with Optional Guy Kit	1
4-1. Tripod Components	3
5-1. Tripod Leg, Slide Collar Components	4
5-2. Comparison of One Leg Pointing Downhill (right) Versus Two Legs Pointing Downhill	5
5-3. Tripod Mast and Insert	6
5-4. Mast Attachment to Tripod Base	7
5-5. Guy Collar	8

5-6. Leg Attachment 9
5-7. Staking the Tripod Feet 10
5-8. Ground Rod and Clamp 11
5-9. Lightning Rod and Tripod Grounding Lug 12
5-10. CM204 Crossarm..... 13
5-11. Enclosure with the –MM Bracket..... 14
5-12. Enclosure with the –LM Bracket..... 15
6-1. CM210 Crossarm Mounting Kit (shown with user-supplied pipe) 16
6-2. CM216 Mast Mounting Kit 17
6-3. CM220 Right Angle Mounting Kit..... 18
6-4. CM225 Pyranometer Mounting Stand..... 19
6-5. CM230 Adjustable Angle Mounting Kit 20
6-6. CM235 Magnetic Mounting Stand 21
6-7. RM Young Gill Radiation Shield 22

CM106 Tripod

1. General

The CM106 is a general purpose tripod that can be used for mounting sensors, solar panels, antennas, and instrument enclosures. The CM106 is constructed from galvanized steel, with individually adjustable legs that allow installation over uneven terrain. Height of the mast is 7 ft (2.1 m), or 10 ft (3 m) with the mast extension.

The CM106 includes lightning and grounding rods, grounding cables, UV resistant cable ties, and stakes for securing the tripod feet to the ground. An optional guy kit is recommended for sites that experience high wind speeds (see Section 2, Allowable Wind Speed Specifications). Instrument enclosures can be purchased with mounting brackets that attach to either the mast or leg section as shown in Section 5.7.

The CM106 can be used for a variety of applications. For meteorological stations, sensors are mounted to the tripod using mounting brackets appropriate for the model of sensor. For non-meteorological applications the tripod can be used to mount instrument enclosures, solar panels, junction boxes, or antennas.



FIGURE 1-1. CM106 Tripod with Optional Guy Kit

2. Specifications

Measurement Height	
Upper Mast Retracted:	7 ft (2.1 m)
Upper Mast Extended:	10 ft (3 m)
Vertical Load Limit:	100 lb (45 kg)
Mast Outer Diameter	
Main Lower Mast:	1.90 in. (48 mm)
Retractable Upper:	1.74 in. (44 mm)
Base Diameter:	9.3 ft (2.8 m)
Leveling Adjustment:	Slide collars on each leg, adjust individually
Leg Base:	4 in. by 5 in. with four 0.62 in. holes for stakes
Portability:	Collapsible to 8 in. diameter by 6 ft length
Weight with Mast:	40 lb (18 kg)
Maximum Slope Angle:	22° or 40% grade (assuming leg clamp pins are engaged in holes under the legs and that one leg points downhill while the other two legs point uphill)

Allowable Wind Speeds*

Tripod Configuration	Sustained Wind	Wind Gust
Mast Extended, Unguyed	65 mph (29 m/s)	84 mph (38 m/s)
Mast Retracted, Unguyed	80 mph (36 m/s)	104 mph (46 m/s)
Mast Extended, Guyed	100 mph (45 m/s)	130 mph (58 m/s)
Mast Retracted, Guyed	115 mph (51 m/s)	150 mph (67 m/s)

**Allowable wind speed values assume:*

- 14 x 16 in. enclosure at mast base
- 10.5 x 16.5 in. solar panel at mast base
- Crossarm and sensors (1.4 ft² projected area) at mast top
- Adequate ground anchors (stakes can pull out at lower wind speeds)

3. Tools List (for tripod, mast, enclosures, and crossarms)

- 1/2" and 7/16" open end wrenches
- adjustable wrench
- Phillips head screw drivers (medium, small)
- Straight bit screwdrivers (large, medium)
- 12" torpedo level
- side-cut pliers
- pencil
- tape measure
- compass and site declination angle
- shovel
- sledge hammer (for driving ground rod and stakes)
- step ladder

4. Tripod Components

Figure 4-1 shows the tripod components. The tripod base is packaged with the mast, ground rod, lightning rod and (6) stakes. The ground rod clamp, lightning rod, cable ties, and grounding wires are enclosed in a bag. The optional guy kit is packaged separately.

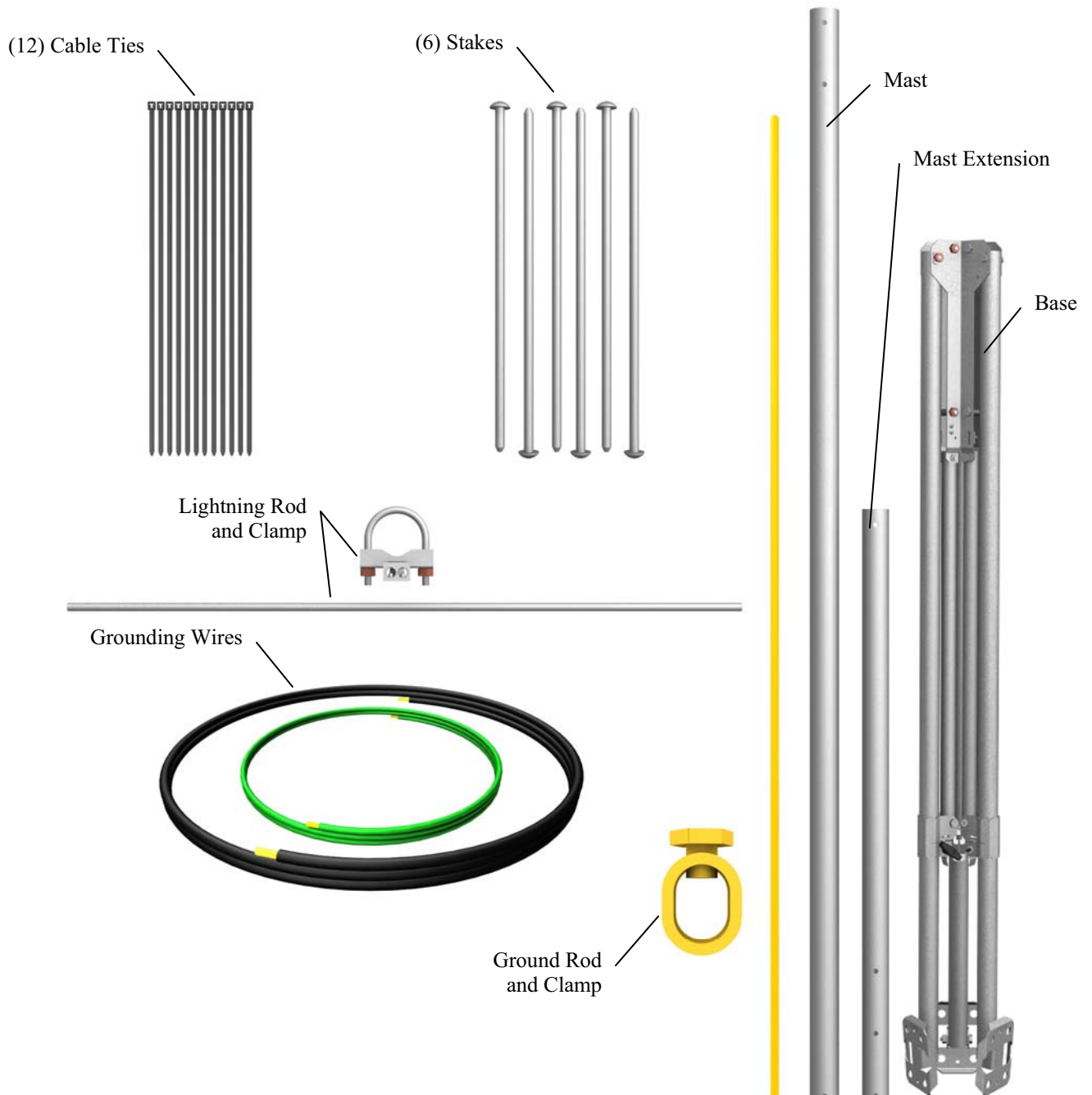

FIGURE 4-1. Tripod Components

5. Tripod Installation

5.1 Tripod Base

WARNING

Tripod installation near power lines is dangerous. The minimum safe recommended distance from overhead power lines is 2 times the height of the tripod and mast combined. Call Blue Stakes to locate buried utilities prior to installation.

The tripod base has three legs, which are individually adjustable, that allow the tripod to be installed over non-level terrain.

Prepare the area where the tripod will be installed. The tripod requires an area approximately 9.3 ft (2.8 m) in diameter. Natural vegetation and the ground surface should be disturbed as little as possible, but brush and tall weeds should be removed.

Stand the tripod base up on end, and rotate the feet perpendicular to the legs. Each leg has a slide collar and T-knob with a spring loaded pin that locks into holes located on the underside of the leg as shown in Figure 5-1.

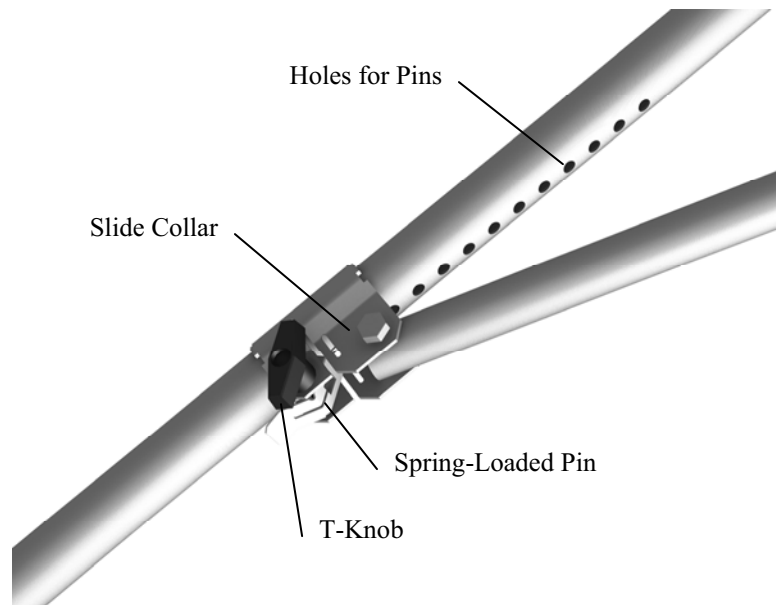

FIGURE 5-1. Tripod Leg, Slide Collar Components

5.1.1 Mounting on a Relatively Flat Area

Loosen the T-knob and extend each leg until the pin engages in a hole (depress the tab to disengage the pin from a hole). With the legs extended, orient the tripod so that one of the legs points South (assuming the instrument enclosure with -MM Mast Mount bracket will face North). If the instrument enclosure has the -LM Leg Mount bracket, orient the tripod so that the enclosure will

mount to one of the three leg mount positions on the tripod, facing the desired direction. The tripod is typically plumbed after the mast has been installed, as described in Section 5.2.

5.1.2 Mounting on an Incline

Loosen the T-knob and extend each leg until the pin engages in a hole (depress the tab to disengage the pin from a hole). With the legs extended, orient the tripod so that one leg points downhill and the other two legs point uphill. The tripod is more stable with only one leg pointed downhill because the mast is closer to the center of the footprint (see Figure 5-2).

The tripod is typically plumbed after the mast has been installed, as described in Section 5.2.

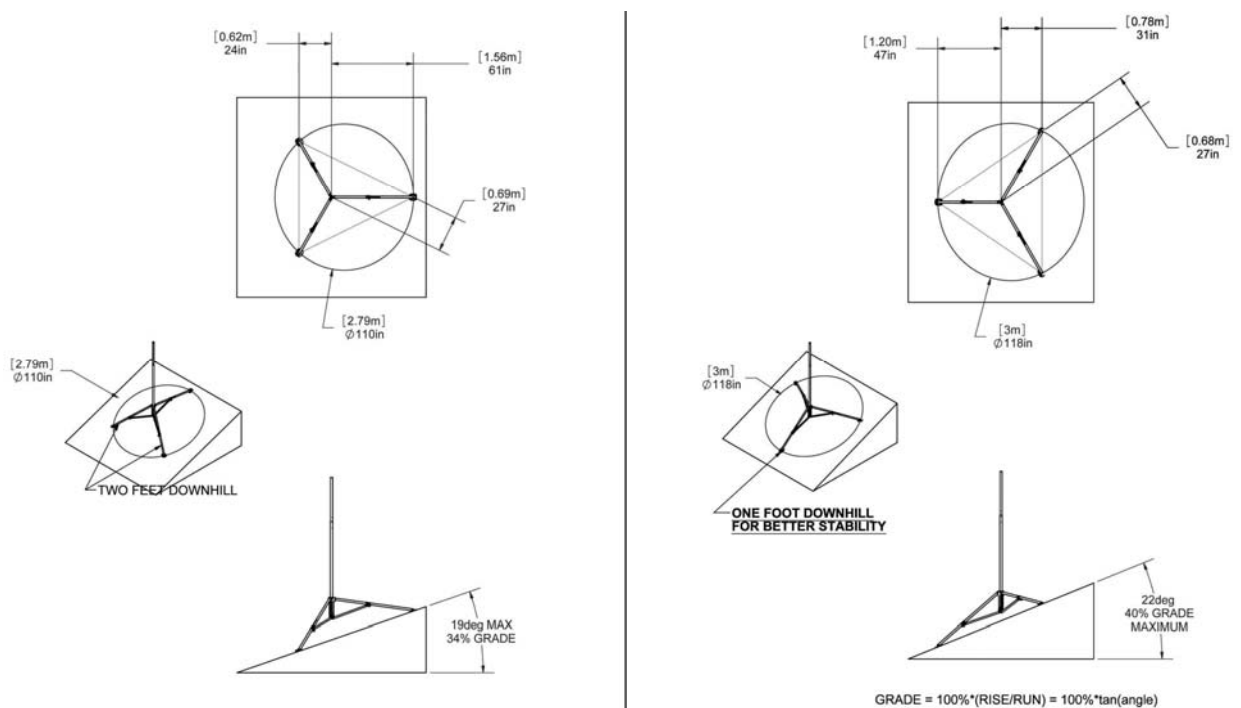

FIGURE 5-2. Comparison of One Leg Pointing Downhill (right) Versus Two Legs Pointing Downhill

5.2 Mast

The CM106 includes a mast extension that can be fully extended for a 10 ft (3 m) height, or partially extended for a 7 ft (2.1 m) height. Remove the bolts in the extension, align the holes in the insert with holes in the mast, and install the four bolts previously removed.

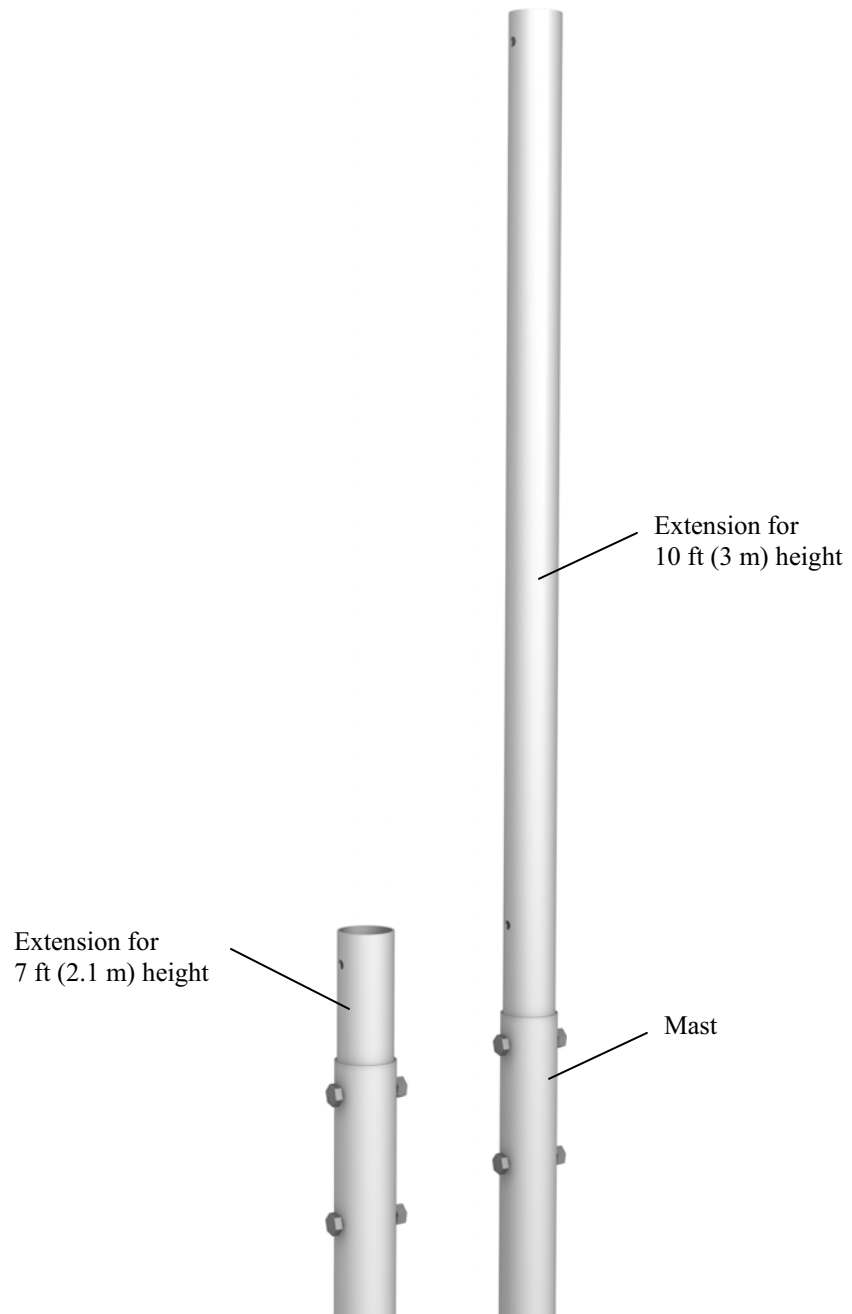

FIGURE 5-3. Tripod Mast and Insert

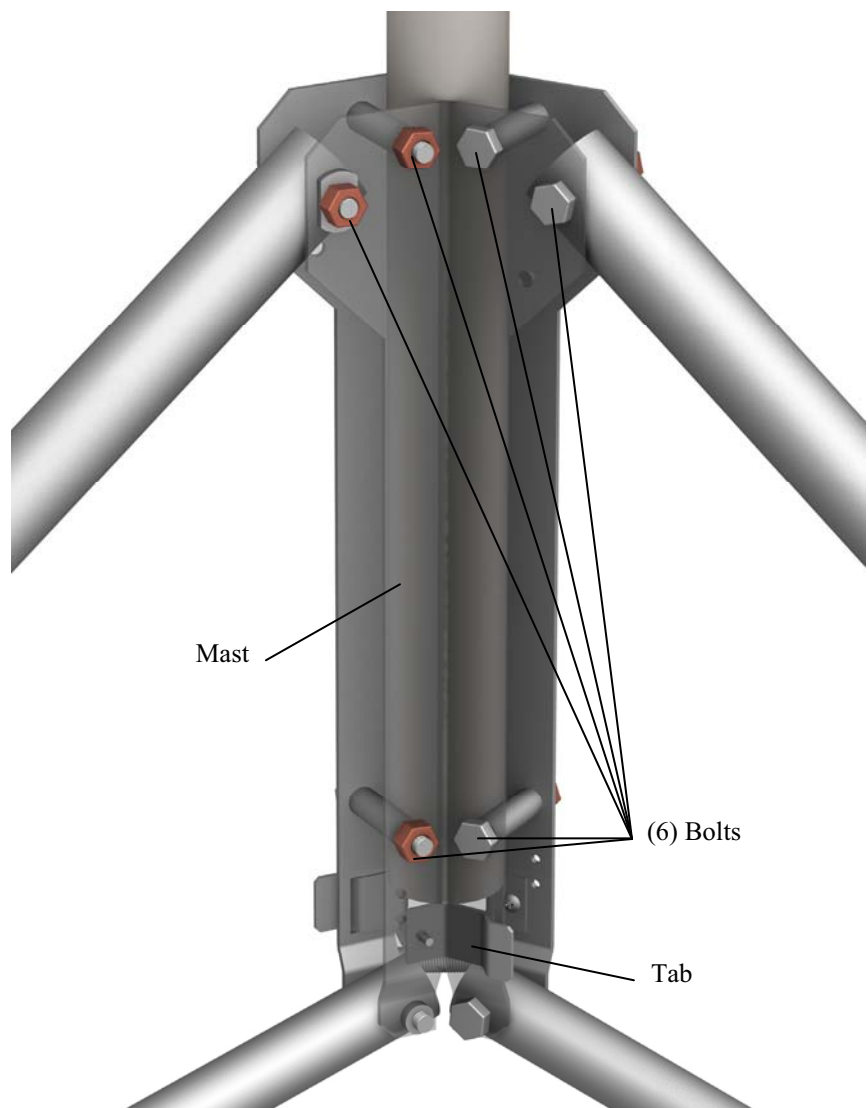

FIGURE 5-4. Mast Attachment to Tripod Base

Loosen the nine bolts shown in Figure 5-4. Slide the mast into the tripod base, making sure that it extends below the lower bolts and rests on the tab. Tighten the six bolts to secure the mast.

Plumb the tripod by adjusting the northeast and south facing legs. With a level on the East side of the mast, adjust the Northeast leg for plumb. With the level on the South side of the mast, adjust the South leg for plumb. Tighten the T-knobs after the adjustments have been made.

5.3 Installing the Optional Guy Kit

PN 27117 CM106 Guy Kit can be ordered separately for areas that experience high wind speeds (Section 2). Install the guy brackets to the mast as shown in Figure 5-5. Attach the three guy wires to the guy collar and slide the collar over the mast so that the collar butts against the brackets.

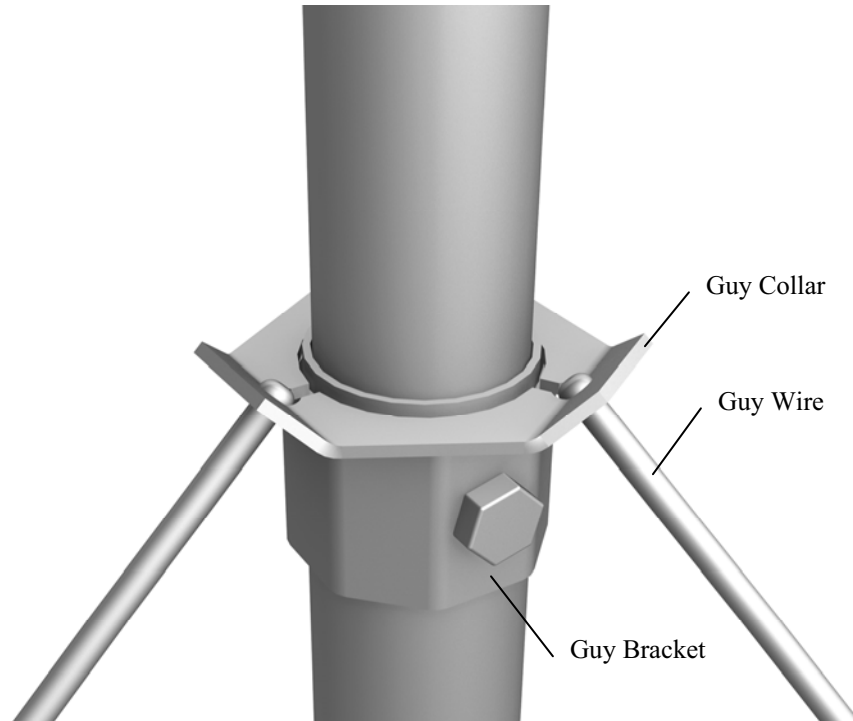

FIGURE 5-5. Guy Collar

On the end of each guy line is a case and hardware to attach to the turnbuckles. Unscrew the turnbuckles so that only 1/2 in of thread extends beyond the inside of the turnbuckle body. Attach the case and turnbuckle to the tripod leg as shown in Fig 5-6. Loosen the Phillips screw, and remove the slack in the guy line by feeding the load end of the guy wire through the wedge while pulling up on the dead end. If the load end of the guy wire can't be fed through the case, use a small flat screwdriver to push the wedge forward into the case to disengage wedge.

After the slack has been removed from the guy lines, tighten the Phillips screws and tighten the turnbuckles to tension the guy lines.

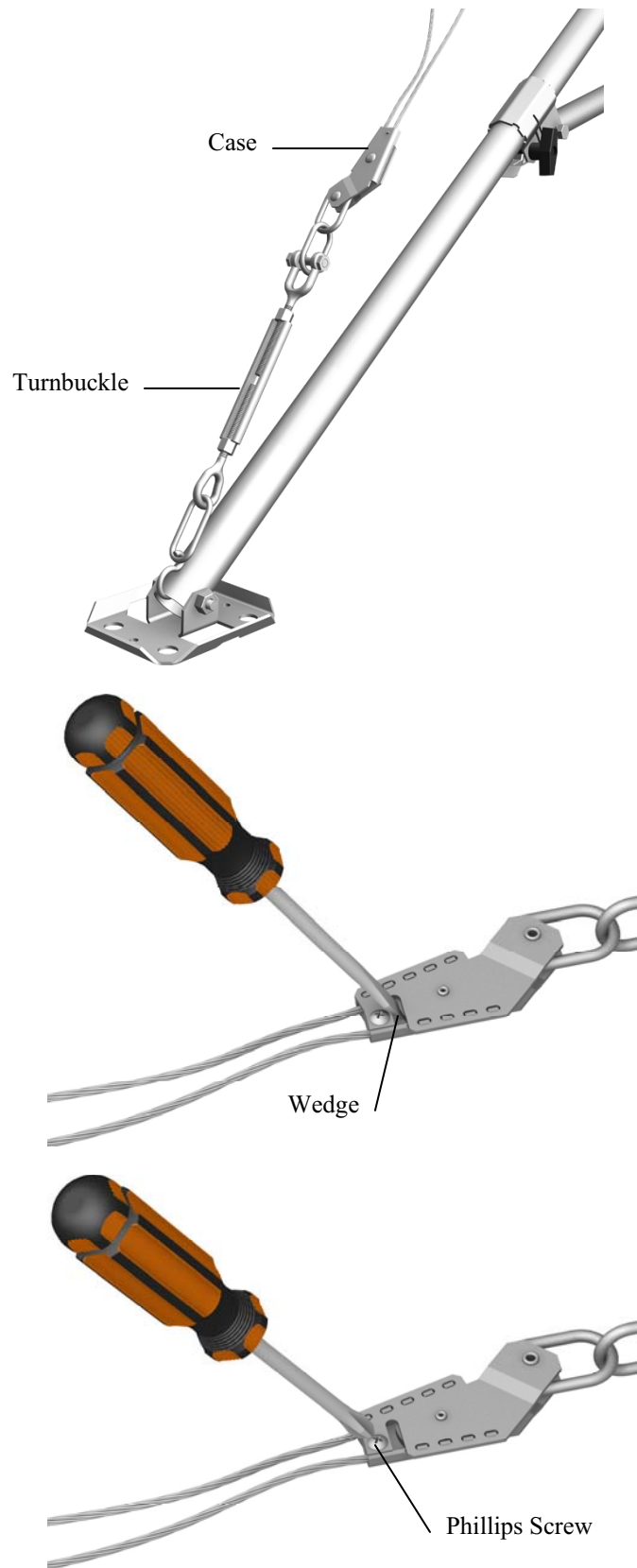

FIGURE 5-6. Leg Attachment

5.4 Staking the Tripod Feet

Six stakes are provided for securing the tripod feet to the ground. Drive two stakes through holes in each foot at an angle as shown in Figure 5-7.

Stakes may not be adequate depending on soil structure, maximum wind speeds experienced at the site, mast height, or wind load from the instrumentation. For questionable situations, additional stakes (PN 17049) or even concrete footings for the tripod feet and guy anchors should be considered.



FIGURE 5-7. Staking the Tripod Feet

5.5 Tripod Grounding

Place the clamp over the ground rod and drive the rod (close to the center of the tripod) using a sledge hammer or fence post driver. Strip 1/2" inch of insulation from both ends of the black 4 AWG ground wire. Insert one end of the ground wire between the clamp and ground rod and tighten the bolt on the clamp. Attach the other end of the ground wire to the lug on the tripod base as shown in Figure 5-8.

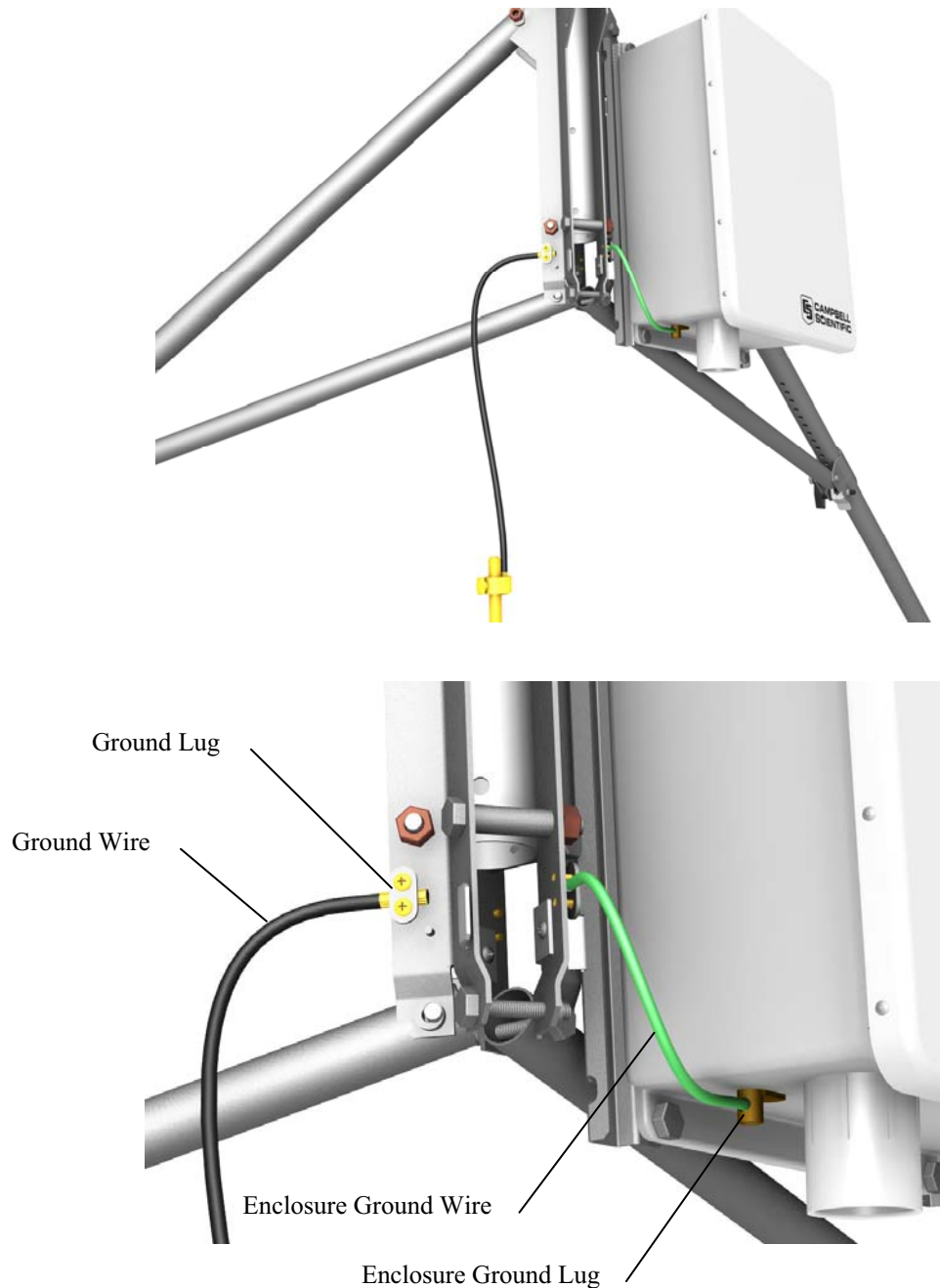

FIGURE 5-8. Ground Rod and Clamp

Strip 1/2" of insulation from the ends of the green 12 AWG wire. Attach one end of the wire to the tripod ground lug, and the other end to the enclosure ground lug as shown in Figure 5-9.

Mount the lightning rod and clamp to the tripod mast with pointed tip up, and notch at bottom, as shown in Figure 5-9.

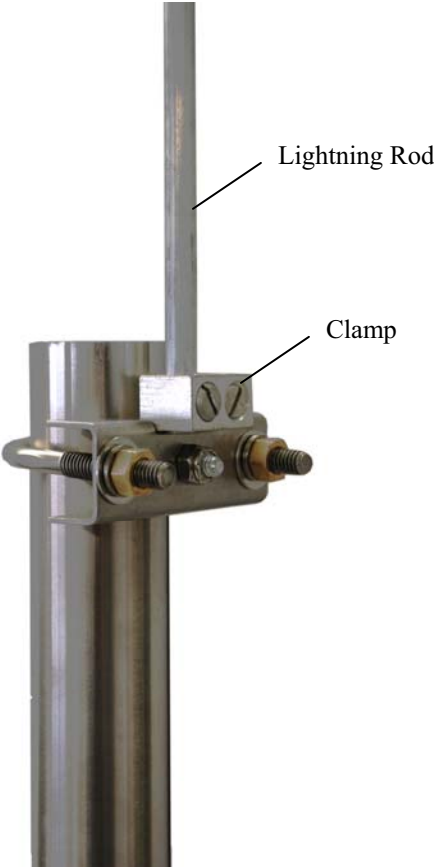

FIGURE 5-9. Lightning Rod and Tripod Grounding Lug

5.6 Crossarm Attachment

Attach the CM202 (2 ft, 0.6m), CM204 (4 ft, 1.2m), or CM206 (6 ft, 1.8m) crossarm to the tripod mast as shown in Figure 5-10. For wind sensors, the crossarm should be approximately 103 inches above the ground for a 3m mounting height, or 64 inches for a 2m mounting height. Typically the crossarm is oriented East/West for wind sensors, North/South for pyranometers.

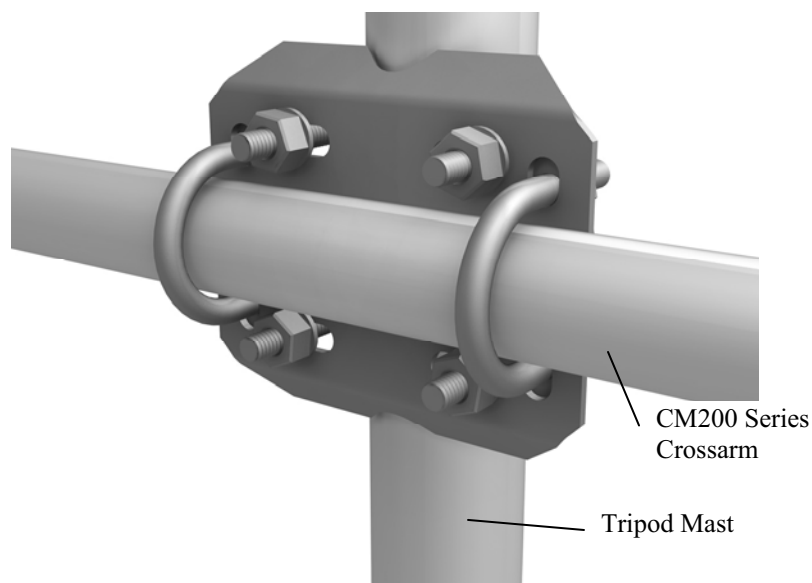

FIGURE 5-10. CM204 Crossarm

5.7 Enclosure Attachment

The ENC 10/12, ENC 12/14, ENC 14/16, and ENC 16/18 enclosures can be ordered with mounting brackets for the CM106 tripod. All enclosure models can be mounted to the tripod mast (above the legs) with the –MM Mast Mount bracket option. All enclosure models except the ENC 16/18 can be mounted to the tripod base and leg with the –LM Leg Mount bracket option. Two enclosures with the –LM brackets can be mounted in a “back to back” configuration.

5.7.1 Enclosure Mounting to Tripod Mast

An enclosure ordered with the –MM bracket has a three-piece top and bottom brackets with a U-bolt for each bracket.

Attach an enclosure with the –MM mounting bracket to the tripod mast as follows:

Remove the U-bolts washers and nuts from the brackets.

Position the enclosure against the tripod’s mast (North side recommended).

Install the U-bolts, flat washers, lock washers, and nuts. Tighten the nuts until the lock washers are compressed.

Route the 14 AWG wire from the grounding lug on the bottom side of the enclosure to the grounding lug on the base of the tripod (Figure 5-8). Strip 1/2" of insulation from each end of the wire. Insert wire ends into the grounding lugs and tighten.

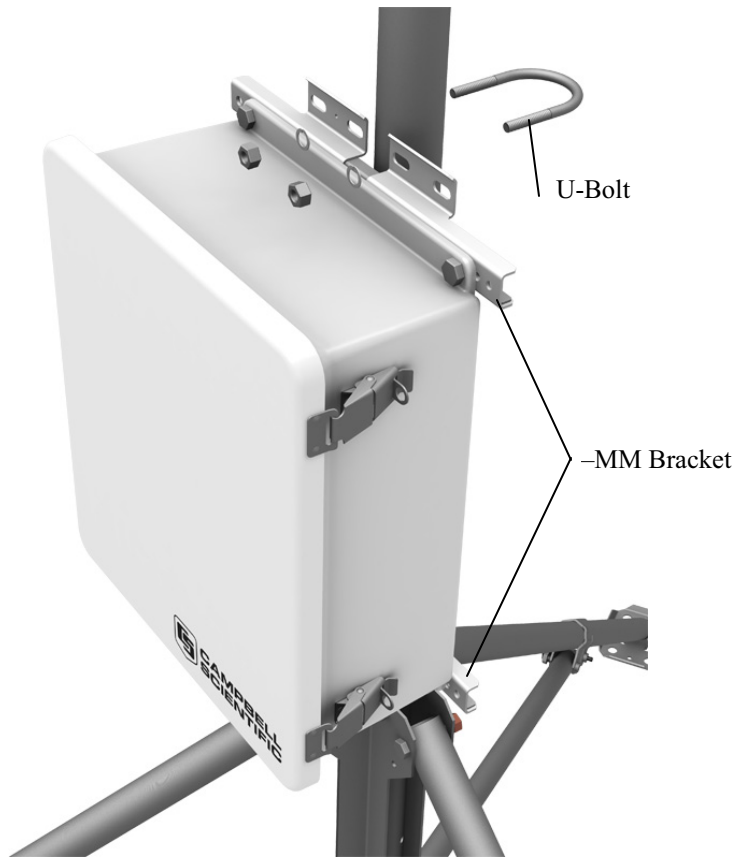

FIGURE 5-11. Enclosure with the -MM Bracket

5.7.2 Enclosure Mounting to Tripod Leg

An enclosure ordered with the -LM bracket has a bracket on each side of the enclosure, and a U-bolt bracket for securing the enclosure to a tripod leg.

Attach an enclosure with the -LM mounting bracket to the tripod base as follows:

Slide the keyhole notch in upper corner of the -LM bracket over the extended screw head located on the tripod base as shown in Figure 5-12, and engage the notch in the lower corner of the -LM bracket with the enclosure tab. There are two places on the tripod base with provisions for mounting enclosures with the -LM brackets.

Remove the washers, nuts and U-bolt from the U-bolt bracket. Install the bracket as shown in Figure 5-12 (top). Tighten the nuts on the U-bolt until the lock washers are compressed.

Route the 14 AWG wire from the grounding lug on the bottom side of the enclosure to the grounding lug on the base of the tripod (Figure 5-8). Strip 1/2" of insulation from each end of the wire. Insert wire ends into the grounding lugs and tighten.

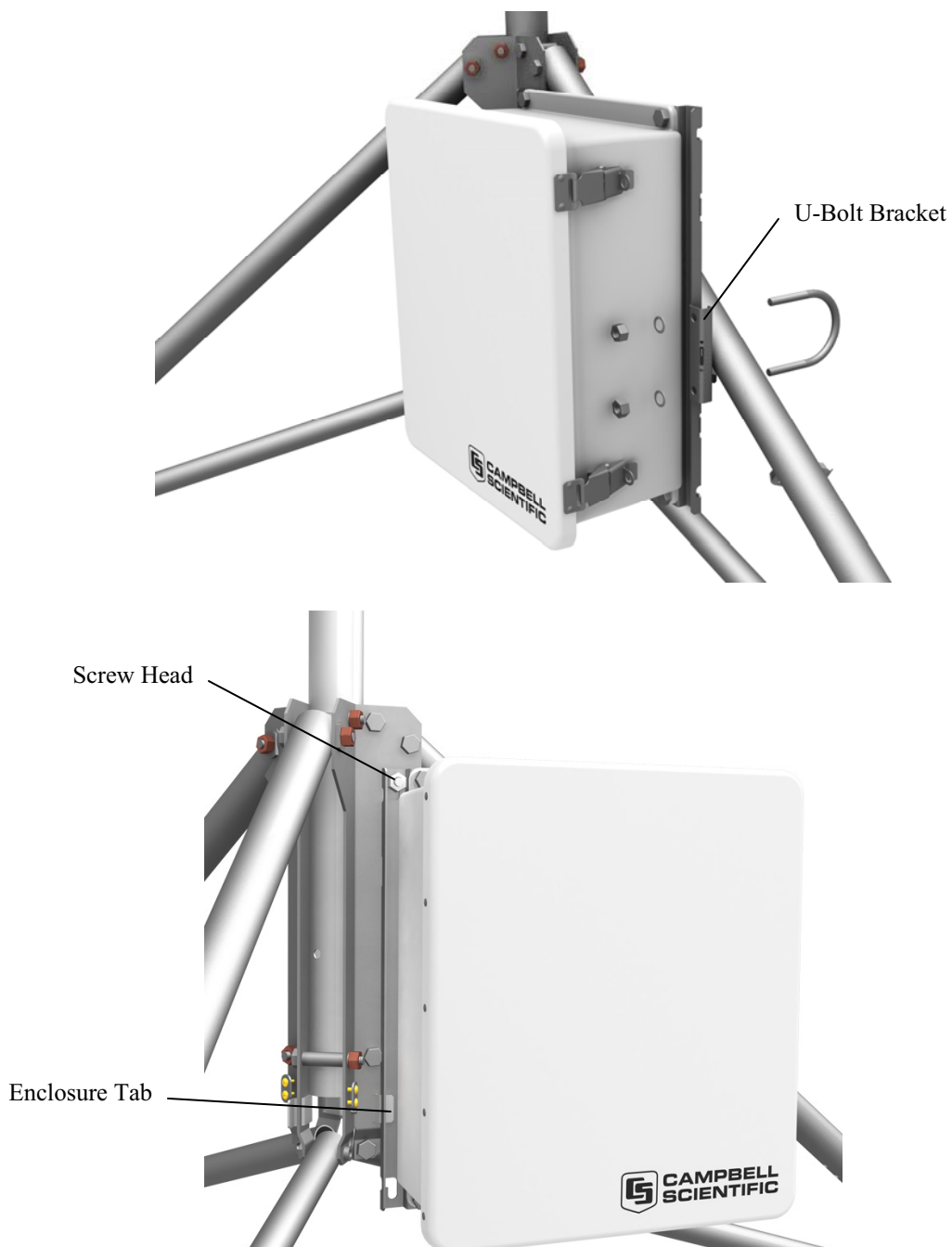

FIGURE 5-12. Enclosure with the -LM Bracket

6. Mounting Brackets

Mounting brackets covered in this section have U-bolts that attach to vertical and/or horizontal pipes with the following ranges of outside diameters:

	inches	mm	Nominal Pipe Size (inches)
1.5" U-bolt	1.0 – 1.5	25.4 – 38.1	¾ – 1
2" U-bolt	1.3 – 2.1	33.0 – 53.3	1 – 1 ½
2" U-bolt with plastic V-block	1.0 – 2.1	25.4 – 53.3	¾ – 1 ½

Some of the brackets (e.g. the CM210) include 1.5" and 2" U-bolts to extend the range of pipe diameters that the bracket can accommodate. Brackets with holes for a 1.5" U-bolt will accept a user-supplied 1.75" U-bolt.

6.1 CM210 Crossarm Mounting Kit

CM200 series crossarms include a CM210 bracket as shown in Figure 6-1. The CM210 can be ordered separately to attach a user-supplied pipe (1.0 – 1.5" OD) to a mast or tower leg (1.0 – 2.1" OD), or to attach a crossarm to two tower legs.

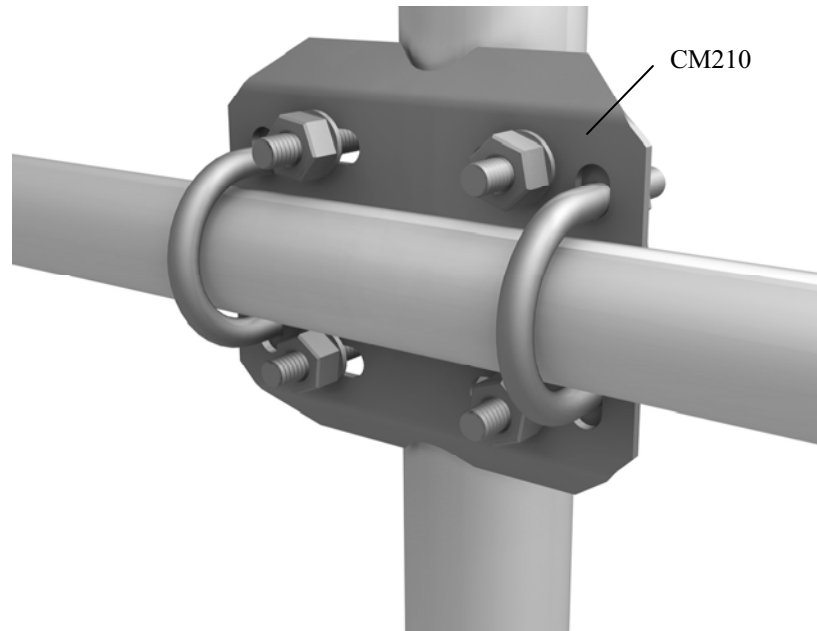

FIGURE 6-1. CM210 Crossarm Mounting Kit
(shown with user-supplied pipe)

6.2 CM216 Mast Mounting Kit

The CM216 attaches to the top of the mast, and provides a 3/4" or 1" mounting pipe (1.05" or 1.32" OD) that extends 4" above the mast, as shown in Figure 6-2.



FIGURE 6-2. CM216 Mast Mounting Kit

6.3 CM220 Right Angle Mounting Kit

The CM220 attaches a vertical pipe (1.0 – 1.5” OD) to the CM200 series crossarms or horizontal pipe (1.0 – 1.5” OD) as shown in Figure 6-3.



FIGURE 6-3. CM220 Right Angle Mounting Kit

6.4 CM225 and 18098 Pyranometer Mounting Stand

The CM225 is used to attach a pyranometer or quantum sensor to a horizontal pipe (1.0 to 2.1" OD) or vertical pole (1.0 to 2.1" OD).

The LI200X pyranometer and LI190SB quantum sensor mount to the CM225 via the LI200S leveling base (see Figure 6-4). The CS300 pyranometer mounts to the CM225 via the 18356 leveling base. The CMP3 and LP02 pyranometers include their own bubble level and leveling screws allowing them to mount directly to the CM225.

The 18098 provides a larger surface for mounting a user-supplied Eppley pyranometer.

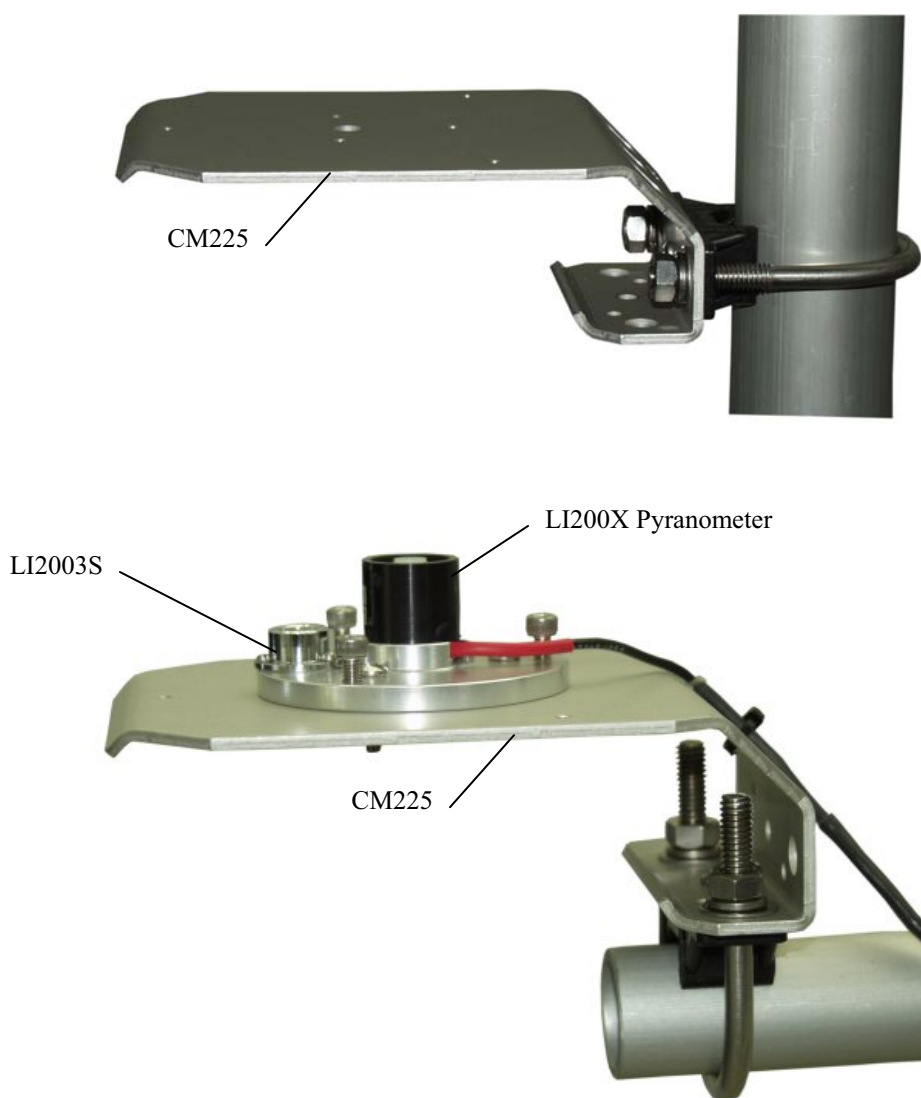

FIGURE 6-4. CM225 Pyranometer Mounting Stand

6.5 CM230 Adjustable Angle Mounting Kit

The CM230 mounts an antenna (1.0 – 1.5" OD) to a mast or vertical pipe (1.3 – 2.1" OD) as shown in Figure 6-5. The bracket allows the antenna to be adjusted for different angles.

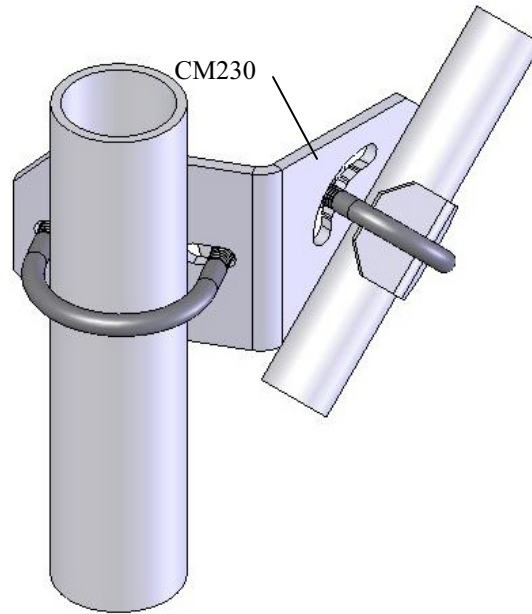

FIGURE 6-5. CM230 Adjustable Angle Mounting Kit

6.6 CM235 Magnetic Mounting Stand

The CM235 provides a 3.5" (8.8 cm) square platform for mounting magnetic base antennas. The CM235 attaches to horizontal or vertical pipes (1.0 – 2.1" OD) as shown in Figure 6-6.



FIGURE 6-6. CM235 Magnetic Mounting Stand

6.7 RM Young Gill Radiation Shields

RM Young Gill Radiation Shields are used to house and attach temperature and relative humidity sensors to the tripod mast (1.0 – 2.1” OD) or crossarm as shown in Figure 6-7. Radiation shields ship with the U-bolt configured for attachment to a vertical pipe. To attach the radiation shield to a horizontal pipe, the U-bolt and plastic V-block must be moved to the other set of holes.

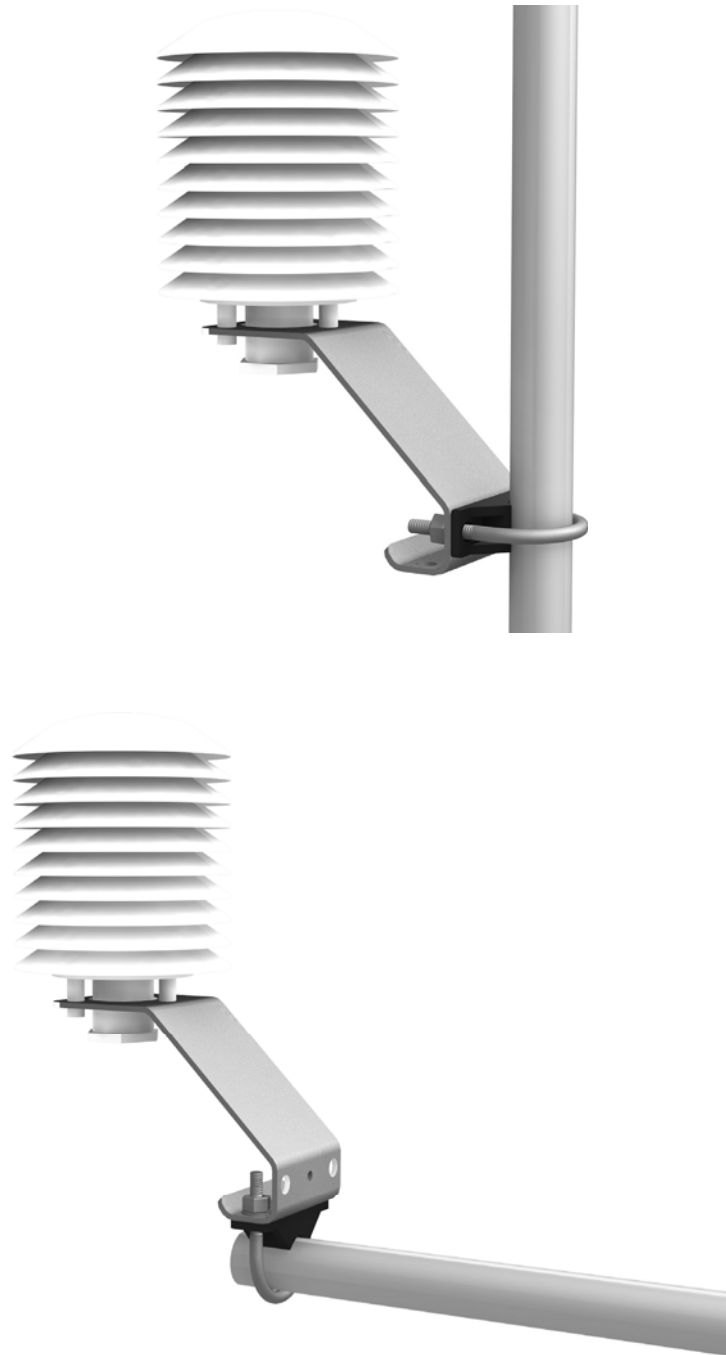

FIGURE 6-7. RM Young Gill Radiation Shield

Campbell Scientific Companies

Campbell Scientific, Inc. (CSI)

815 West 1800 North
Logan, Utah 84321
UNITED STATES
www.campbellsci.com • info@campbellsci.com

Campbell Scientific Africa Pty. Ltd. (CSAf)

PO Box 2450
Somerset West 7129
SOUTH AFRICA
www.csafrica.co.za • cleroux@csafrica.co.za

Campbell Scientific Australia Pty. Ltd. (CSA)

PO Box 444
Thuringowa Central
QLD 4812 AUSTRALIA
www.campbellsci.com.au • info@campbellsci.com.au

Campbell Scientific do Brazil Ltda. (CSB)

Rua Luisa Crapsi Orsi, 15 Butantã
CEP: 005543-000 São Paulo SP BRAZIL
www.campbellsci.com.br • suporte@campbellsci.com.br

Campbell Scientific Canada Corp. (CSC)

11564 - 149th Street NW
Edmonton, Alberta T5M 1W7
CANADA
www.campbellsci.ca • dataloggers@campbellsci.ca

Campbell Scientific Centro Caribe S.A. (CSCC)

300 N Cementerio, Edificio Breller
Santo Domingo, Heredia 40305
COSTA RICA
www.campbellsci.cc • info@campbellsci.cc

Campbell Scientific Ltd. (CSL)

Campbell Park
80 Hathern Road
Shepshed, Loughborough LE12 9GX
UNITED KINGDOM
www.campbellsci.co.uk • sales@campbellsci.co.uk

Campbell Scientific Ltd. (France)

3 Avenue de la Division Leclerc
92160 ANTONY
FRANCE
www.campbellsci.fr • info@campbellsci.fr

Campbell Scientific Spain, S. L.

Avda. Pompeu Fabra 7-9, local 1
08024 Barcelona
SPAIN
www.campbellsci.es • info@campbellsci.es

Please visit www.campbellsci.com to obtain contact information for your local US or International representative.