

# CM106, CM106K

## Instrumentation Tripod and Tripod Kit

The CM106 is a general purpose tripod that can be used for mounting sensors, solar panels, antennas, and instrument enclosures. The CM106 is constructed from galvanized steel, with individually adjusted legs that allow installation over uneven terrain. Height of the mast is 7 ft (2.1 m), or 10 ft (3 m) with the mast extension.

The CM106 includes lightning and grounding rods, grounding cables, UV resistant cable ties, and stakes for securing the tripod feet to the ground. An optional guy kit is recommended for sites that may experience high wind speeds (see Allowable Wind Speeds Specifications on page 2). Instrument enclosures can be purchased with mounting brackets that attach to either the mast or leg base.

The CM106 can be used for a variety of applications. For meteorological stations, sensors are mounted to the tripod using mounting brackets appropriate for the model of sensor. For non-meteorological applications the tripod can be used to mount instrument enclosures, solar panels, junction boxes, or antennas.

### Features

- Individually adjustable legs; each leg has a spring loaded pin that engages into holes on the underside of the leg along with knob to clamp.
- Campbell Scientific enclosures can be mounted to the mast or leg section (enclosure must be ordered with the appropriate mounting brackets).

### CM106K Tripod Kit

The CM106K Tripod Kit is intended for overseas customers. It contains hardware for constructing a tripod. The galvanized steel pipes used for the mast, legs, and leg braces are purchased locally, which greatly reduces overseas shipping costs. Specifically, the customer will need to purchase the following:

- (1) 1 1/2 NPS SCH40 [DN 40 mm] steel pipe with 100.0-in. [254 cm] length
- (3) 3/4 NPS SCH40 [DN 20 mm] steel pipes with 72.0-in. [182.9 cm] length
- (3) 3/4 NPS SCH40 [DN 20 mm] steel pipes with 48.0-in. [121.9 cm] length

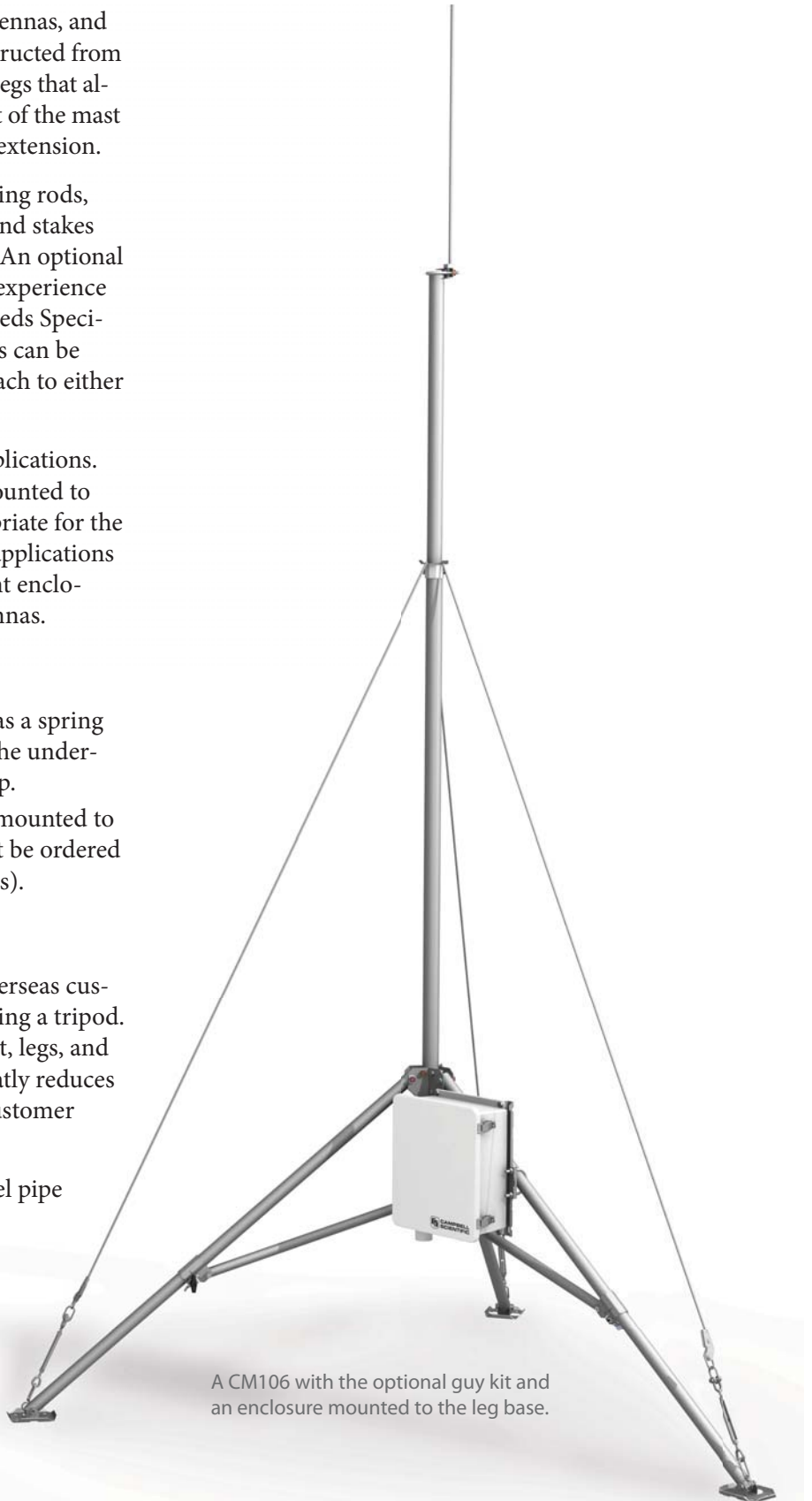

A CM106 with the optional guy kit and an enclosure mounted to the leg base.

## Ordering Information

### Tripod and Tripod Kits

**CM106** 7 ft (2.1 m) or 10 ft (3 m) galvanized-steel tripod with grounding kit

**CM106K** CM106 Tripod Kit.

### Common Accessory

**27117** Optional tripod guy kit for the CM106

## Specifications

### Measurement Height

**Upper Mast Retracted:** 7 ft (2.1 m)

**Upper Mast Extended:** 10 ft (3 m)

**Vertical Load Limit:** 100 lb (45 kg)

### Mast Outer Diameter

**Main Lower Mast:** 1.90 in. (48 mm)

**Retractable Upper:** 1.74 in. (44 mm)

**Base Diameter:** 9.3 ft (2.8 m)

**Leveling Adjustment:** Slide collars on each leg adjust individually

**Leg Base:** 4 in. by 5 in. with four 0.62 in. holes for ground stake

**Portability:** Collapsible to 8 in. diameter by 6 ft length

**Weight with Mast:** 40 lb (18 kg)

**Maximum Slope Angle\*:** 22° or 40% grade

### Allowable Wind Speeds\*\*

Tripod Configuration	Sustained Wind	Wind Gust
Mast Extended, Unguyed	65 mph (29 m/s)	84 mph (38 m/s)
Mast Retracted, Unguyed	80 mph (36 m/s)	104 mph (46 m/s)
Mast Extended, Guyed	100 mph (45 m/s)	130 mph (58 m/s)
Mast Retracted, Guyed	115 mph (51 m/s)	150 mph (67 m/s)

\*Maximum slope angle specification assumes that the leg clamp pins are engaged in the holes under the legs, and that one leg points downhill while the other two legs point uphill.

\*\*Allowable wind speed values assume:

- 14 x 16 in. enclosure at mast base
- 10.5 x 16.5 in. solar panel at mast base
- Crossarm and sensors (1.4 ft<sup>2</sup> projected area) at mast top
- Adequate ground anchors (stakes can pull out at lower wind speeds)



An enclosure mounted to the mast of the CM106.



Back of an enclosure mounted to the leg base of the CM106.

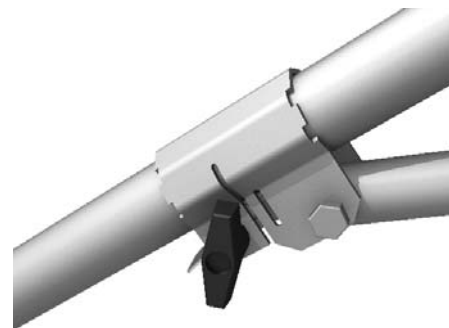

A close up of the adjustable leg clamp.

