



CHP 1 Pyrheliometer

FOR UNATTENDED NORMAL INCIDENCE DIRECT SOLAR RADIATION MEASUREMENT

INTRODUCTION

Solar radiation is the driving force behind biological and geophysical processes in meteorology, climate and our environment. The sun irradiates the top of the earth's atmosphere at an average intensity of 1367 W/m^2 . As the solar rays travel through our atmosphere they are absorbed and scattered. This results in different components of solar radiation reaching the earth's surface. The direct component travels in a straight beam from the sun, whilst a diffuse component comes from all directions, due to the atmospheric scattering process.

A pyrheliometer is an instrument designed specifically to measure the direct beam solar irradiance with a field of view limited to 5° . This is achieved by the shape of the collimation tube, with precision apertures, and the detector design.

The front aperture is fitted with a quartz window to protect the instrument and to act as a filter that passes solar radiation between 200 nm and 4000 nm in wavelength. CHP 1 includes a rain shield and integrated alignment aids.

CHP 1 Pyrheliometer

CHP 1 is a new pyrheliometer that builds on the legacy of the CH 1, offering the reliability and durability of its predecessor together with important improvements. The detector is similar to that used in the CMP 21 and 22 pyranometers, which minimizes the influence of ambient temperature fluctuations and provides a fast response time. Both Pt-100 and 10 k Ω thermistor temperature sensors are fitted as standard, to allow use of the individual temperature response data supplied with each CHP 1. Thanks to the signal cable connector and screw-in desiccant cartridge the new design is easy to install and maintain.

The specifications exceed ISO and WMO performance criteria for First Class Normal Incidence Pyrheliometers. Every CHP 1 is supplied with a calibration certificate traceable to the World Radiometric Reference.

Applications

CHP 1 is the best all-weather pyrheliometer available for continuous measurements of direct solar radiation and exceeds the specifications for high end solar radiation networks, such as the Baseline Surface Radiation Network (BSRN). These networks need accurate and reliable long-term measurements for climate change investigations.

An industrial sector with similar requirements is renewable energy. For research into photo-voltaic systems and materials, accurate direct solar irradiance data is needed. When 'prospecting' for sites to locate solar farms, the incoming energy available throughout the year is a key part of the decision making process.

Building a system

A pyrheliometer needs to be pointed at the sun at all times so that the solar disk always falls within the field of view of the instrument. Kipp & Zonen sun trackers provide a stable mounting to keep the pyrheliometer pointing at the sun to accurately measure the direct solar radiation. More details can be found in our dedicated sun trackers brochure.

Specifications

ISO CLASSIFICATION	First Class
Response time (95%)	5 s
Zero offsets due to temperature change (5 K/hr)	$\pm 1 \text{ W/m}^2$
Non-stability (change/year)	$\pm 0.5\%$
Non-linearity (0 to 1000 W/m^2)	$\pm 0.2\%$
Temperature dependence of sensitivity	$\pm 0.5\%$ (-20 to +50°C)
Sensitivity	7 to 14 $\mu\text{V/W/m}^2$
Impedance	10 to 100 Ω
Operating temperature	-40 to +80°C
Spectral range (50% points)	200 to 4000 nm
Typical signal output for atmospheric applications	0 to 15 mV
Maximum irradiance	4000 W/m^2
Expected daily uncertainty	$\pm 1\%$
Full opening view angle	$5^\circ \pm 0.2^\circ$
Slope angle	$1^\circ \pm 0.2^\circ$
Required tracking accuracy	$\pm 0.5^\circ$ from ideal
Weight (excluding cable)	1 kg

CHP 1 has a standard cable length of 10 m.
Optional cable lengths 25 m and 50 m.

Fitted with both 10 K Thermistor and Pt-100 temperature sensor as standard

Supplied with individual temperature dependence test data

Note: The performance specifications quoted are worst-case and/or maximum values

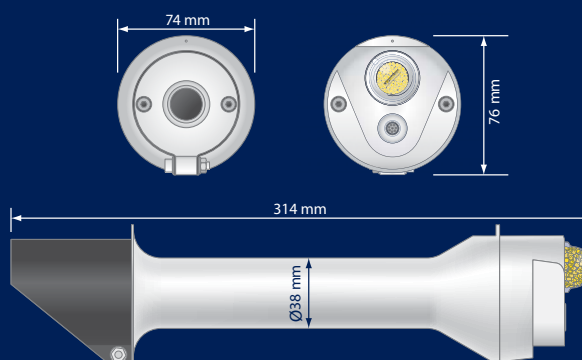

Go to www.kippzonen.com for your local distributor

HEAD OFFICE

Kipp & Zonen B.V.
Delftechpark 36, 2628 XH Delft
P.O. Box 507, 2600 AM Delft
The Netherlands
T: +31 (0) 15 2755 210
F: +31 (0) 15 2620 351
info@kippzonen.com

Kipp & Zonen B.V. reserve the right to alter specifications of the equipment described in this documentation without prior notice



CAMPBELLSCIENTIFIC
CANADA CORP.

11564 - 149 street - edmonton - alberta - T5M 1W7
tel 780.454.2505 fax 780.454.2655
www.campbellsci.ca