

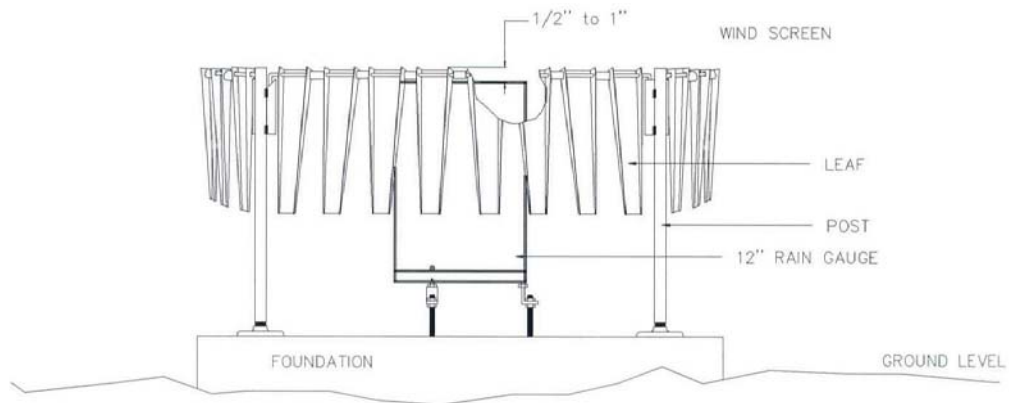

260-953 Alter-Type Wind Screen
for Tipping Bucket Rain Gages

8/10

Campbell Scientific (Canada) Corp refers to this product as Alter Screen 24



WARRANTY AND ASSISTANCE

This equipment is warranted by CAMPBELL SCIENTIFIC (CANADA) CORP. ("CSC") to be free from defects in materials and workmanship under normal use and service for **twelve (12) months** from date of shipment unless specified otherwise. ***** **Batteries are not warranted.** ***** CSC's obligation under this warranty is limited to repairing or replacing (at CSC's option) defective products. The customer shall assume all costs of removing, reinstalling, and shipping defective products to CSC. CSC will return such products by surface carrier prepaid. This warranty shall not apply to any CSC products which have been subjected to modification, misuse, neglect, accidents of nature, or shipping damage. This warranty is in lieu of all other warranties, expressed or implied, including warranties of merchantability or fitness for a particular purpose. CSC is not liable for special, indirect, incidental, or consequential damages.

Products may not be returned without prior authorization. To obtain a Return Merchandise Authorization (RMA), contact CAMPBELL SCIENTIFIC (CANADA) CORP., at (780) 454-2505. An RMA number will be issued in order to facilitate Repair Personnel in identifying an instrument upon arrival. Please write this number clearly on the outside of the shipping container. Include description of symptoms and all pertinent details.

CAMPBELL SCIENTIFIC (CANADA) CORP. does not accept collect calls.

Non-warranty products returned for repair should be accompanied by a purchase order to cover repair costs.



CAMPBELL SCIENTIFIC
C A N A D A C O R P .

11564 - 149 street - edmonton - alberta - T5M 1W7
tel 780.454.2505 fax 780.454.2655

www.campbellsci.ca

PLEASE READ FIRST

About this manual

Please note that this manual was originally produced by Campbell Scientific Inc. (CSI) primarily for the US market. Some spellings, weights and measures may reflect this origin.

Some useful conversion factors:

Area:	1 in ² (square inch) = 645 mm ²
Length:	1 in. (inch) = 25.4 mm 1 ft (foot) = 304.8 mm 1 yard = 0.914 m 1 mile = 1.609 km
Mass:	1 oz. (ounce) = 28.35 g 1 lb (pound weight) = 0.454 kg
Pressure:	1 psi (lb/in ²) = 68.95 mb
Volume:	1 US gallon = 3.785 litres

In addition, part ordering numbers may vary. For example, the CABLE5CBL is a CSI part number and known as a FIN5COND at Campbell Scientific Canada (CSC). CSC Technical Support will be pleased to assist with any questions.

260-953 Table of Contents

PDF viewers note: These page numbers refer to the printed version of this document. Use the Adobe Acrobat® bookmarks tab for links to specific sections.

- 1. Introduction 1**
- 2. Specifications 1**
- 3. Installation 2**
 - 3.1 Site Considerations 2
 - 3.2 Ring Assembly 2
 - 3.3 Posts 3
 - 3.4 Gate 4
 - 3.5 Mounting the Ring Quadrants onto the Posts 4
- 4. Maintenance 5**

Figures

- 3-1. Foundation Size and Post Placement 2
- 3-2. Leaf and Spacer Assembly 3
- 3-3. Properly Installed 260-953 3
- 3-4. Gate Quadrant Mounted onto Posts 4

260-953 Alter-Type Wind Screen for Tipping Bucket Rain Gages

1. Introduction

The 260-953 is a wind screen for our tipping bucket rain gages that can minimize the effect of strong winds on the rain measurements. It includes 32 leaves that swing as the wind moves past them. The leaves are evenly spaced on a 48-in.-diameter ring. The ring is comprised of four quadrants. Each quadrant mounts onto 36-in.-long posts made of galvanized-steel pipe.

The 260-953 should be installed so that the top edge of the rain gauge funnel is ½ in. to 1 in. below the top edge of the wind screen leaves. Typically, the wind screen is mounted onto the concrete pad that also supports the rain gage. However, concrete piers or wooden supports can also be used. To function properly, both the rain gage and wind screen need to be installed correctly.

2. Specifications

Type: Alter

Manufacturer: Novalynx

Leaves:

Number: 32

Material: zinc-plated 20-gauge steel

Width: 3 in. (7.6 cm)

Length: 16 in. (40.6 cm)

Posts:

Number: four

Length: 3 ft (0.9 m)

Material: galvanized steel

Ring Installed Diameter: 4 ft (1.2 m)

Spacers: 3/4-in. EMT

Installed Height: 3 ft (0.9 m)

Shipping Weight: 45 lbs (20.4 kg)

3. Installation

The tipping bucket rain gage is typically installed before the wind screen (refer to the rain gage's manual for installation procedures).

3.1 Site Considerations

The foundation size must be at least 4 ft x 4 ft if the same concrete or wooden foundation is used for both the wind screen and tipping bucket rain gage (see Figure 3-1). A larger area may be desirable to more easily access the wind screen and tipping bucket rain gage.

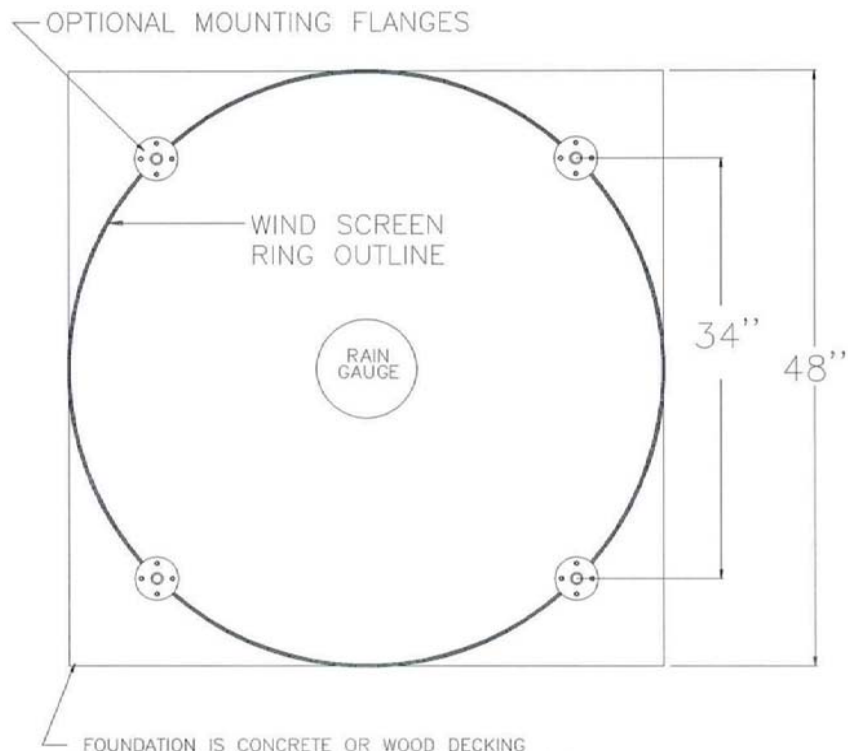

FIGURE 3-1. Foundation Size and Post Placement

Sites where there is open ground between the wind screen and the rain gage should be cleared of weeds or grass. A gravel path is recommended to permit access to the rain gage during wet conditions.

3.2 Ring Assembly

On each ring quadrant, alternate the wind screen leaves and spacers as shown in Figure 3.2. The leaves should be installed so that the flat sides of the leaves will face the rain gage.

CAUTION

The wind screen leaves have very sharp edges. Use leather gloves while handling the leaves, and avoid brushing against them.

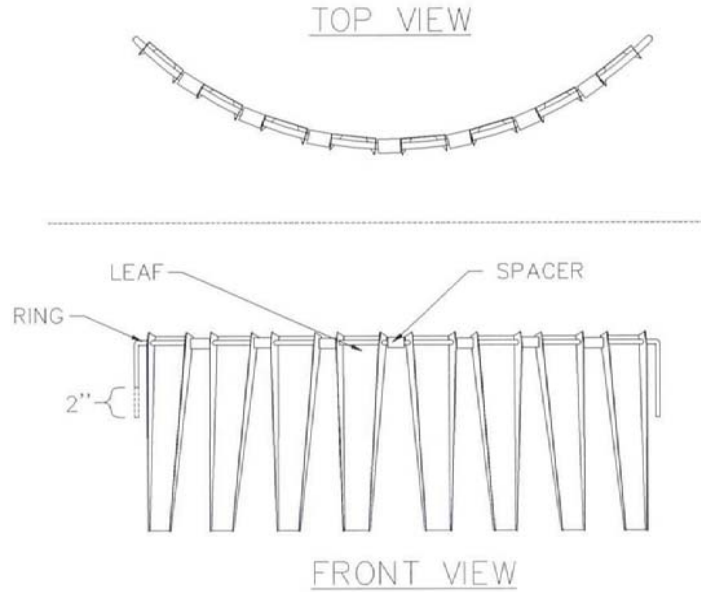

NOTES:

1. Typical of three quadrants.
2. Gate quadrant has left vertical rod that is 2" shorter.

FIGURE 3-2. Leaf and Spacer Assembly

3.3 Posts

Spacing between the wind screen posts is 34 in. (see Figure 3-1). If a concrete foundation is used, the posts can be directly embedded into the concrete.

To ensure the proper height, assemble the wind screen (see Section 3.2) and temporarily install it at its desired location. If the posts are too short to obtain the correct height (1/2 in. to 1 in. above rain gage), use pipe couplings and extension pipes to increase the height (see Figure 3.3).

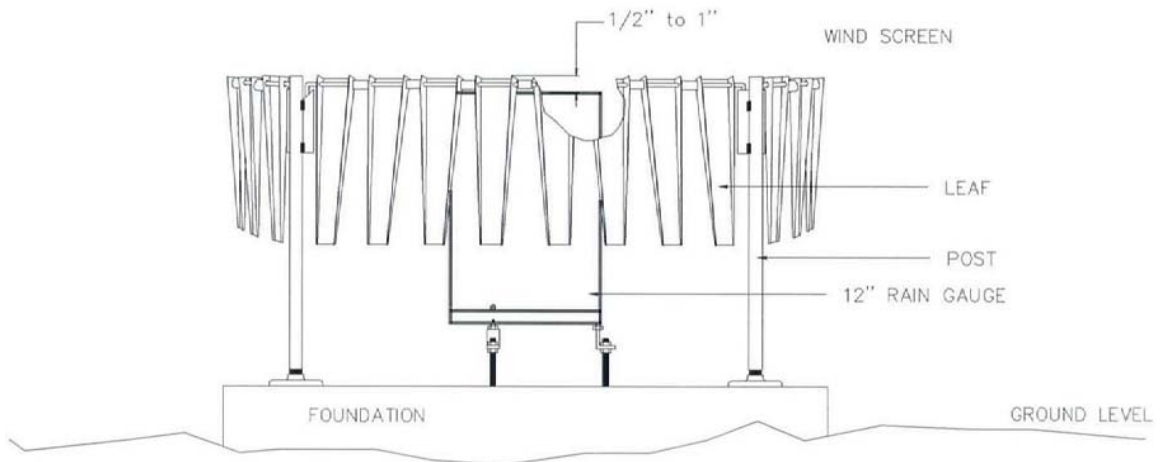

NOTES:

1. Rain gauge shown in bold lines.
2. Cutaway shows spacing between top of wind screen and top of rain gauge.

FIGURE 3-3. Properly Installed 260-953

Each post has a 3/4-in. NPT thread at one end (see Figure 3.4). If the posts are to be directly embedded into the concrete, use a floor flange on the end of each post as an anchor to help prevent it from pulling out of the concrete. Short pieces of pipe with threaded couplers may also be embedded into the concrete, allowing the posts to be threaded directly into the concrete. The posts should be leveled vertically during installation.

3.4 Gate

One of the posts has a 45° notch cut out of it. This post is for the wind screen gate (see Figure 3.4), which is used to access the tipping bucket rain gage. Plan the installation so that the gate is at the desired location for accessing the rain gage.

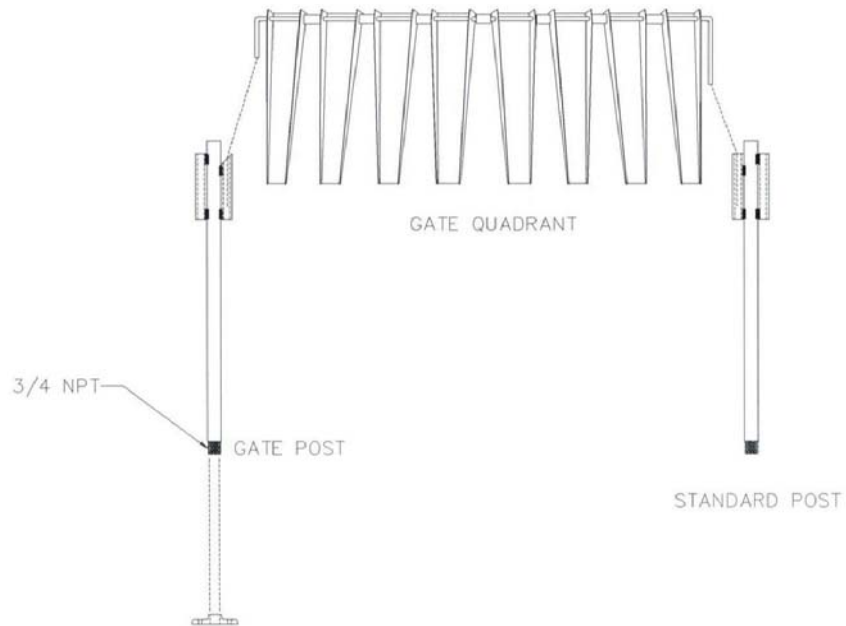

FIGURE 3-4. Gate Quadrant Mounted onto Posts

3.5 Mounting the Ring Quadrants onto the Posts

Two people typically are required to lift the ring quadrants and place them onto the posts. Each end of the ring quadrant has a rod. These rods fit into the short pieces of pipe that are welded onto the posts (see Figure 3.4). The gate quadrant has a shorter rod that fits into the post with a 45° notch (see Figure 3.4).

The posts may need to be flexed slightly to fit the ring quadrants. After the ring quadrants have been installed, inspect each leaf to ensure that it can swing freely.

4. Maintenance

Refer to your tipping bucket rain gage manual for tipping bucket rain gage maintenance.

CAUTION

Avoid brushing against the wind screen leaves while servicing the rain gage. Removal of the wind screen while servicing the rain gage can help avoid injuries caused by the leaves' sharp edges. Use leather gloves while handling the wind screen.

Keep weeds, grass, and other plants from growing into and interfering with the rain gage and wind screen leaves. Remove any debris and dirt that may have accumulated onto the surfaces of the leaves.

Inspect the wind screen parts for rust, and wire brush rusted areas.

NOTE

The wind screen components can be spray painted or cold galvanized to help prevent rust.

Check the posts and flanges for loose mounting hardware.

Campbell Scientific Companies

Campbell Scientific, Inc. (CSI)

815 West 1800 North
Logan, Utah 84321
UNITED STATES
www.campbellsci.com • info@campbellsci.com

Campbell Scientific Africa Pty. Ltd. (CSAf)

PO Box 2450
Somerset West 7129
SOUTH AFRICA
www.csafrica.co.za • cleroux@csafrica.co.za

Campbell Scientific Australia Pty. Ltd. (CSA)

PO Box 444
Thuringowa Central
QLD 4812 AUSTRALIA
www.campbellsci.com.au • info@campbellsci.com.au

Campbell Scientific do Brazil Ltda. (CSB)

Rua Luisa Crapsi Orsi, 15 Butantã
CEP: 005543-000 São Paulo SP BRAZIL
www.campbellsci.com.br • suporte@campbellsci.com.br

Campbell Scientific Canada Corp. (CSC)

11564 - 149th Street NW
Edmonton, Alberta T5M 1W7
CANADA
www.campbellsci.ca • dataloggers@campbellsci.ca

Campbell Scientific Centro Caribe S.A. (CSCC)

300 N Cementerio, Edificio Breller
Santo Domingo, Heredia 40305
COSTA RICA
www.campbellsci.cc • info@campbellsci.cc

Campbell Scientific Ltd. (CSL)

Campbell Park
80 Hathern Road
Shepshed, Loughborough LE12 9GX
UNITED KINGDOM
www.campbellsci.co.uk • sales@campbellsci.co.uk

Campbell Scientific Ltd. (France)

Miniparc du Verger - Bat. H
1, rue de Terre Neuve - Les Ulis
91967 COURTABOEUF CEDEX
FRANCE
www.campbellsci.fr • info@campbellsci.fr

Campbell Scientific Spain, S. L.

Avda. Pompeu Fabra 7-9, local 1
08024 Barcelona
SPAIN
www.campbellsci.es • info@campbellsci.es

Please visit www.campbellsci.com to obtain contact information for your local US or International representative.