

INSTRUCTION MANUAL

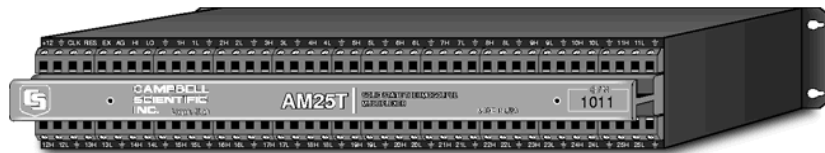

AM25T Solid State Multiplexer

Revision: 1/10



Copyright © 1995-2010
Campbell Scientific, Inc.

WARRANTY AND ASSISTANCE

This equipment is warranted by CAMPBELL SCIENTIFIC (CANADA) CORP. ("CSC") to be free from defects in materials and workmanship under normal use and service for **twelve (12) months** from date of shipment unless specified otherwise. ***** **Batteries are not warranted.** ***** CSC's obligation under this warranty is limited to repairing or replacing (at CSC's option) defective products. The customer shall assume all costs of removing, reinstalling, and shipping defective products to CSC. CSC will return such products by surface carrier prepaid. This warranty shall not apply to any CSC products which have been subjected to modification, misuse, neglect, accidents of nature, or shipping damage. This warranty is in lieu of all other warranties, expressed or implied, including warranties of merchantability or fitness for a particular purpose. CSC is not liable for special, indirect, incidental, or consequential damages.

Products may not be returned without prior authorization. To obtain a Return Merchandise Authorization (RMA), contact CAMPBELL SCIENTIFIC (CANADA) CORP., at (780) 454-2505. An RMA number will be issued in order to facilitate Repair Personnel in identifying an instrument upon arrival. Please write this number clearly on the outside of the shipping container. Include description of symptoms and all pertinent details.

CAMPBELL SCIENTIFIC (CANADA) CORP. does not accept collect calls.

Non-warranty products returned for repair should be accompanied by a purchase order to cover repair costs.



CAMPBELL SCIENTIFIC
C A N A D A C O R P .

11564 - 149 street - edmonton - alberta - T5M 1W7
tel 780.454.2505 fax 780.454.2655

www.campbellsci.ca

AM25T Solid State Multiplexer

Table of Contents

PDF viewers note: These page numbers refer to the printed version of this document. Use the Adobe Acrobat® bookmarks tab for links to specific sections.

1. General	1
1.1 AM25T Specifications.....	1
1.2 Physical Description	2
1.3 Operation	3
2. Installation	4
3. Datalogger to AM25T Wiring	5
4. Sensor to AM25T Wiring	6
4.1 Thermocouple Measurement	6
4.2 Differential Analog Measurements.....	7
4.3 Mixed Sensor Types	7
5. General Measurement Considerations	8
6. Datalogger Programming	8
6.1 CRBasic Programming	8
6.1.1 Example CRBasic Programs	11
6.1.1.1 CR1000 Example Program 1.....	11
6.1.1.2 CR1000 Example Program 2.....	12
6.2 Edlog Programming.....	13
6.2.1 Example CR10(X) Programs	14
6.2.2 Example CR23X Program	18

Appendices

A. Single-Ended Measurements	A-1
A.1 Directions for Single-Ended Measurements	A-1
A.2 Indexing with Loops	A-5
B. Differences Between the AM25T, AM416, and the AM32	B-1

Figures

1. AM25T Thermocouple Multiplexer.....	3
2. External Battery Connections	6
3. Differential Measurement of Type T Thermocouple	7
4. Differential Voltage Measurement.....	7
A-1. Single-Ended Measurement of a Type T Thermocouple	A-2
A-2. Single-Ended Measurement.....	A-5

Tables

3-1. Datalogger to AM25T Wiring	5
6-1. Wiring for CR1000 Example 1.....	11
6-2. Wiring for CR1000 Example 2.....	12
6-3. RTD Excitation Voltage and Measurement Range for AM25T Multiplexers Prior to Serial Number 1839	14
6-4. Wiring for CR10(X) Examples.....	14
6-5. Wiring for CR23X Example.....	18
A-1. Values in Input Storage; Input Location Not Indexed.....	A-5
A-2. Values in Input Storage; with Input Location Index and without Step Loop Index Instruction	A-6
A-3. Values in Input Storage; with Input Location Index and Step Loop Index Instruction.....	A-6

Program Examples

1. CR1000 Program Using One Instruction to Measure Both the Reference Temperature and Thermocouples.....	11
2. CR1000 Program that Uses Separate AM25T Instructions to Measure the PRT and Thermocouples	12
3. CR10(X) Program for Measuring 25 Type T Thermocouples or Voltage Sensors Using a Differential Instruction.....	14
4. CR10(X) Program for Measuring 25 Type T Thermocouples with the Differential Thermocouple Instruction and Long Lead Length Compensation on the RTD Measurement	16
5. CR23X Program for Measuring 25 Type T Thermocouples.....	18
A-1. CR10 Program for Measuring 50 Type T Thermocouples or Voltage Sensors Using a Single-Ended Instruction.....	A-2
A-2. 21X Program for Measuring 50 Type T Thermocouples or Voltage Sensors Using Single-Ended Instruction	A-3
A-3. Single-Ended Thermocouples, Input Location Not Indexed	A-6
A-4. Measuring Single-Ended Thermocouples with the Input Location Indexed and no Step Loop Index	A-7
A-5. Measuring Single-Ended Thermocouples with the Input Location Indexed and Step Loop Index	A-7

AM25T Solid State Multiplexer

1. General

The AM25T Multiplexer increases the number of channels for measuring thermocouples or voltage sensors with Campbell Scientific dataloggers. The AM25T is positioned between the sensors and the datalogger. The datalogger controls the AM25T's solid state relays, sequentially connecting each sensor to the datalogger.

The AM25T is not suitable for resistive bridge measurements (high impedance of the solid state relays) or multiplexing power (25 mA maximum switching current).

A maximum of 25 thermocouples (differential voltage measurement) can be multiplexed by an AM25T. Single-ended voltage measurements are not recommended (Appendix A).

The AM25T must be used in a non-condensing environment. An enclosure is required for field use. In applications where one or two multiplexers are deployed in the field, the ENC12/14 can be used. The ENC16/18 can be used to house several multiplexers at the same site.

1.1 AM25T Specifications

POWER

Unregulated 9.6 V to 16 V; 12 VDC Nominal

CURRENT DRAIN

Quiescent: 0.5 mA
Active: 1.0 mA (typical)

ENABLE

Inactive: < 0.9 V
Active: 3.5 to 5.0 V (7 V max.)

CLOCK

The relays are advanced on the falling edge of the clock pulse (transition from >3.5 V to <1.5 V; 7 V max.). The minimum clock pulse width is limited by the datalogger.

Minimum ON time 50 microseconds
Minimum OFF time 60 microseconds

OPERATING TEMPERATURE

Standard: -40°C to +85°C
RTD accuracy $\pm 0.4^\circ\text{C}$

OPERATING HUMIDITY

Noncondensing: 0 to 95%

DIMENSIONS

Length: 23.6 cm (9.3")
Width: 5.10 cm (2.0")
Depth: 13.2 cm (5.2")

WEIGHT

0.91 kg (2.0 lbs)
3.6 kg (8.0 lbs); Shipping

EXPANDABILITY (nominal)**

2 AM25Ts per CR800 or CR850
4 AM25Ts per CR1000
6 AM25Ts per CR23X
4 AM25Ts per CR10(X)
6 AM25Ts per 21X
7 AM25Ts per CR7 725 Card

MAXIMUM CABLE LENGTH

Multiplexers can be located up to 305 m (1000 ft) from the datalogger. When lightning protection is required, do not exceed 152 m (500 ft) in cable length. The spark gaps will not fire if the heavy ground wire is longer than 152 m (500 ft).

TYPICAL RELAY RESISTANCE

500 Ω

MAXIMUM SWITCHING CURRENT

25 mA; Switching currents greater than 25 mA will damage the relays and render them unusable.

**Assumes sequential activation of multiplexers and that each datalogger channel is uniquely dedicated. If your application requires additional multiplexing capability, please consult CSI for application assistance.

1.2 Physical Description

The AM25T is housed in an anodized aluminum case with a cover that will help reduce temperature gradients across the AM25T's terminal strips (Figure 1).

The terminal strips that run the length of the AM25T are for sensor connections. All inputs are protected by spark gaps. All terminals accept stripped and tinned lead wires up to 1.5 mm (0.059 inches) in diameter. A strain-relief flange is located between the input terminals.

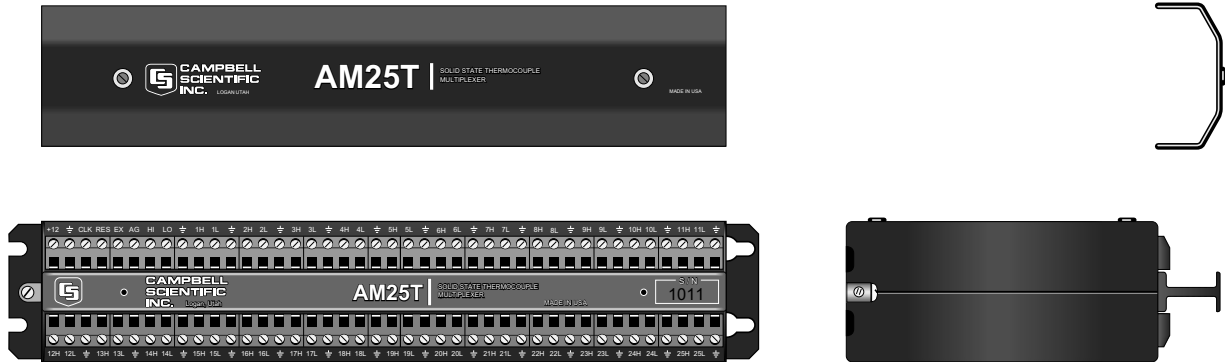

FIGURE 1. AM25T Thermocouple Multiplexer

1.3 Operation

The AM25T is connected to the datalogger with eight insulated wires and a large ground wire. These wires are used to power and control the multiplexer, and connect the common analog inputs to the datalogger.

Measurement Terminals

There are 25 differential channels on the AM25T. These channels are labeled 1H and 1L through 25H and 25L. The channels are sequentially connected and reversed to the common channels HI and LO.

Excitation Terminal

This terminal is used to excite the reference temperature (RTD) on the AM25T. The excitation line is protected from transients with a transorb. (Earlier versions of the AM25T, prior to 1839, used a zener diode for protection. The diode limited the negative excitation voltage to -400 mV).

Power (12 V)

The AM25T requires a 9.6 to 16 VDC (12 VDC nominal) power supply.

In low current drain applications, it is convenient to power the AM25T from the datalogger's battery. For power intensive operations, use a high Amp hour 12 VDC battery.

See Campbell Scientific's application note on power supplies for information on calculating the power requirements of your system.

Ground (GND)

Each differential input channel has a ground terminal located next to it. The ground terminal is common with the power ground and the ground lug on the base. Connect the sensor shields to the ground terminals (≐). Always tie the datalogger and multiplexer to a common earth ground via the grounding lug.

Analog Ground (AG)

The analog ground (AG) terminal is the ground reference for the AM25T reference temperature measurement. AG ground is not common with the other ground terminals labeled (≐). **Terminal AG must be connected to datalogger ground** as shown in Table 3-1.

Reset (RES)

A control port is used to operate the RES channel. The AM25T is reset and activated by applying and holding 5 VDC to the RES channel. Once the AM25T is activated, the AM25T reference temperature can be immediately measured. The AM25T enters its quiescent state when the RES channel is set to 0 VDC.

Clock (CLK)

Pulsing the CLK channel sequentially advances the relays. A control port is used to operate the CLK channel.

The first CLK pulse advances the relays to the reference temperature excitation channel. The second CLK pulse advances the relays and connects HI and LO to 1H and 1L on the multiplexer.

NOTE

Two clock pulses are required to advance to the next adjacent sensor input channel on the AM25T.

The fourth CLK pulse advances the relays and connects HI and LO to 2H and 2L. The sixth CLK pulse advance the relays and connects HI and LO to 3H and 3L. This sequence is continued for the remaining input channels.

2. Installation

The standard AM25T may be operated in a non-condensing environment. An enclosure is required for field use.

Campbell Scientific's ENC12/14 and ENC16/18 enclosures offer a degree of protection against dust, spraying water, oil, falling dirt, or dripping non-corrosive liquids. The enclosures contain plates for multiplexer mounting and conduit bushings for cable entry. These enclosures are rain tight but not waterproof.

The enclosure lids have water resistant gaskets. Electricians putty is shipped with the enclosures to seal around the cable entry to reduce the moisture entering the enclosure. Desiccant should be kept in the enclosure and exchanged regularly or as indicated by the humidity indicator.

U-bolts are used to attach the enclosures to a 1.25" NPT pipe. The enclosure may also be lag-bolted to a wall or similar flat surface.

Fasten the AM25T to the enclosure backplate. Securely fasten the leads to the strain relief flange running between the AM25T terminal strips and install the cover to reduce temperature gradients during thermocouple measurements.

3. Datalogger to AM25T Wiring

When powering the AM25T from the same battery as the datalogger, connect the datalogger to the AM25T as shown in Table 3-1. Two CABLE4CBL-L cables typically carry control, power, and measurement signals between the AM25T and the datalogger.

WARNING

Do not reverse the polarity of the +12 Volt and Ground leads. Damage to the multiplexer, sensors, and datalogger will occur.

A separate battery can be used to power the AM25T. A separate battery might be used when the AM25T is installed some distance from the datalogger. Ground must be connected between the datalogger and the AM25T (Figure 2).

When leads in excess of 152 m (500 feet) are used to connect the datalogger to the AM25T, it may be necessary to compensate for the drop in RTD excitation voltage (program example 4).

Caution

All AM25T inputs are spark gap protected. To ensure that the spark gaps fire, the large ground wire between the AM25T and datalogger must not be greater than 152 m (500 ft). In applications where lightning protection is not required, limit the cable length between the AM25T and datalogger to 305 m (1000 ft).

TABLE 3-1. Datalogger to AM25T Wiring

Function	AM25T	CR10(X)	21X/CR7	CR23X	CR800, CR850, CR1000, CR3000, CR5000, CR9000X
+12V Power	12 V	12 V	12 V	12 V	12 V
Power and Shield Ground	≡	G	≡	G	G
Clock	CLK	Control Port	Control Port	Control Port	Control Port
Reset	RES	Control Port	Control Port	Control Port	Control Port
RTD Excitation	EX	Excitation	Excitation	Excitation	Excitation
Analog Ground	AG	AG	≡	≡	≡
Common High	HI	Diff. Chan. H	Diff. Chan. H	Diff. Chan. H	Diff. Chan. H
Common Low	LO	Diff. Chan. L	Diff. Chan. L	Diff. Chan. L	Diff. Chan. L

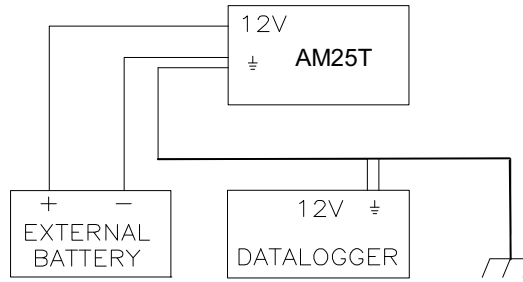

FIGURE 2. External Battery Connections

4. Sensor to AM25T Wiring

This section and the examples describe differential voltage measurements of thermocouples. It is possible to make single-ended measurements with the AM25T, however they are more likely to have problems (Appendix A).

Shield wires are connected to the ground terminal next to the measurement channel and left unattached at the sensor.

4.1 Thermocouple Measurement

An internal reference RTD is located in the AM25T. This reference temperature does not require an additional datalogger input to measure the reference. The RTD is located in the center of the multiplexer on the strain relief flange.

Thermal gradients between the AM25T's sensor input terminals and the RTD cause errors in thermocouple readings. For example, a one degree gradient between input terminals and the RTD will result in a one degree measurement error. The central aluminum (strain relief) bar and the cover are designed to reduce gradients.

Heat conduction along the thermocouple wire, into the terminal strips, can be reduced by coiling some excess lead wire inside the enclosure.

The datalogger manual contains a thorough discussion on thermocouple measurements and error analysis. Consult the datalogger manual for more details.

For a differential voltage measurement of a thermocouple, wire the high side of the thermocouple to the high side of a differential input channel and the low side of the thermocouple to the low side of the channel. Thermocouples that follow the U.S. industry standards use red insulation on the low side of the thermocouple. Wire one thermocouple per differential input channel (Figure 3).

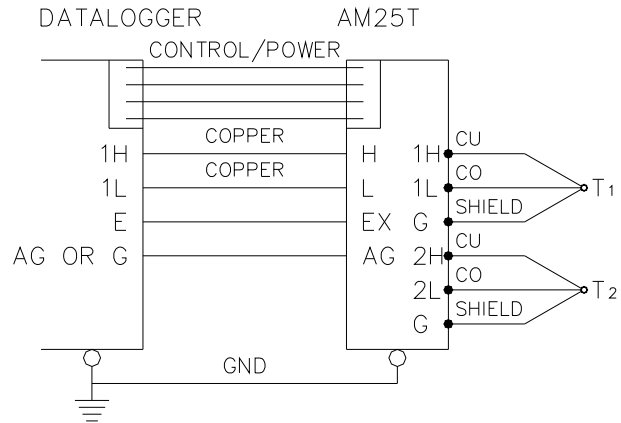

FIGURE 3. Differential Measurement of Type T Thermocouple

4.2 Differential Analog Measurements

Connect one differential sensor to a differential AM25T input channel. Connect the sensor shields to the ground terminals next to the input channel. Up to 25 differential sensors may be measured by one differential channel on the datalogger (Figure 4).

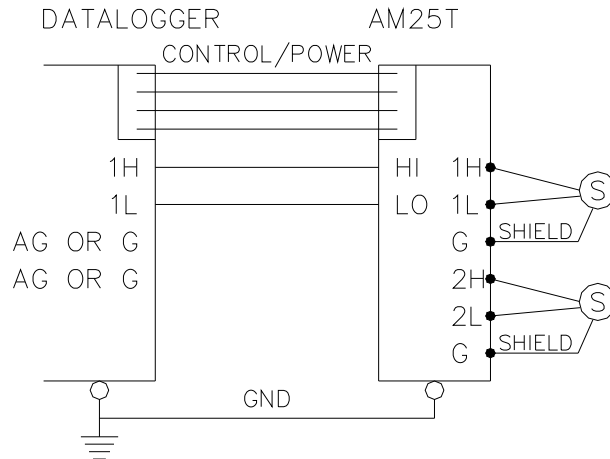

FIGURE 4. Differential Voltage Measurement

4.3 Mixed Sensor Types

Different sensors may be mixed on the AM25T. Additional loops and measurement instructions will be required.

5. General Measurement Considerations

Cables have additional capacitance that increases the time required for a signal to settle its true value. To reduce settling time, Campbell Scientific recommends use of Teflon, polyethylene, or polypropylene insulation around individual conductors. Do not use PVC as conductor insulation. PVC may be used as a cable jacket.

With long lead lengths, a delay within the measurement instruction will allow the capacitance of the lead wires to discharge before the measurement is made. Consult the Measurement Section of your datalogger manual for more information.

6. Datalogger Programming

The datalogger is programmed using either CRBasic or Edlog. Dataloggers that use CRBasic include our CR800, CR850, CR1000, CR3000, CR5000, and CR9000(X). Dataloggers that use Edlog include our CR10(X), 21X, CR23X, and CR7. Both CRBasic and Edlog are included in PC400 and LoggerNet.

6.1 CRBasic Programming

In CRBasic, the AM25T instruction is used to control the AM25T Multiplexer with the datalogger. The instruction will automatically measure the PRT incorporated in the AM25T and use it as a reference temperature for thermocouple measurements.

Syntax

AM25T (Dest, Reps, Range, AM25TChan, DiffChan, TCTYPE, TRef, ClkPort, ResPort, ExChan, RevDiff, SettlingTime, Integ, Mult, Offset)

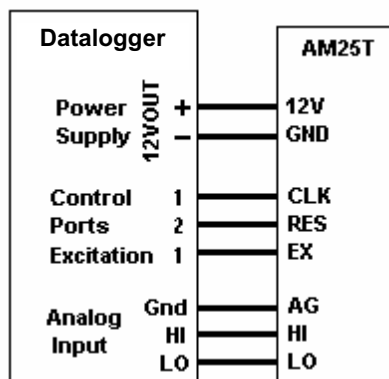

The AM25T instruction has the following parameters:

Dest: The Dest parameter is a variable in which to store the results of the measurement.

Reps: The Reps parameter is the number of times the measurement should be made. Measurements are made on consecutive channels. If the Reps parameter

is greater than 1, the Dest parameter must be a variable array. If 0 is entered, the only measurement that is made is the reference temperature measurement.

Range: The Range parameter is the expected voltage range of the input from the sensor. An alphanumeric or the numeric code can be entered.

The range code options depend on the datalogger used. For example, the range codes for the CR1000 are as follows:

<u>Alphanumeric</u>	<u>Numeric</u>	<u>Description</u>
mV5000	0	± 5000 mV
mV2500	1	± 2500 mV
mV250	2	± 250 mV
mV25	3	± 25 mV
mV7_5	4	± 7.5 mV
mV2_5	5	± 2.5 mV
autorange	6	mV2_5 to mV5000; datalogger tests for and uses most suitable range
mV250C	20	± 250 mV, checks for open input
mV25C	30	± 25 mV, checks for open input
mV7_5C	40	± 7.5 mV, checks for open input
mV2_5C	50	± 2.5 mV, checks for open input
autorangeC	60	mV2_5 to mV5000; datalogger tests for and uses most suitable range, checks for open input

Refer to the CRBasic help for range code options available for your datalogger.

AM25TChan: The AM25TChan parameter specifies the starting input channel for the multiplexer. If the Reps parameter is greater than 1, the additional measurements will be made on sequential channels. If the channel is entered as a negative number, all reps occur on the same channel.

DiffChan: The DiffChan argument is the number of the differential channel to which the first AM25T is connected.

TCType: The TCType argument is used to identify the type of thermocouple being measured. An alphanumeric or numeric code can be entered. Entering a -1 records a voltage, in millivolts, instead of a thermocouple temperature.

<u>Alphanumeric</u>	<u>Numeric</u>	<u>Type</u>
mV	-1	Outputs a voltage, in millivolts
TypeT	0	Copper Constantan
TypeE	1	Chromel Constantan
TypeK	2	Chromel Alumel
TypeJ	3	Iron Constantan
TypeB	4	Platinum Rhodium
TypeR	5	Platinum Rhodium
TypeS	6	Platinum Rhodium

TRef: The TRef argument is the name of the variable which holds the result of the reference temperature measurement.

ClkPort: The ClkPort argument is the control port that will be used to clock the AM25T. One clock port may be used with several AM25Ts. A numeric code is entered for this argument:

<u>Code</u>	<u>Description</u>
1	Control Port 1
2	Control Port 2
3	Control Port 3
4	Control Port 4
5	Control Port 5
6	Control Port 6
7	Control Port 7
8	Control Port 8

ResPort: The ResPort argument is the control port that will be used to enable and reset the AM25T. Each AM25T must have a unique Reset port. A numeric code is entered for this argument; refer to ClkPort above.

ExChan: The ExChan argument is the excitation channel that will be used to provide switched excitation for the PRT reference temperature measurement. An alphanumeric or numeric code can be entered:

<u>Alphanumeric</u>	<u>Numeric</u>	<u>Description</u>
0	0	Temperature not measured
VX1	1	Excitation channel 1
VX2	2	Excitation channel 2
VX3	3	Excitation channel 3

RevDiff: A constant is entered for the RevDiff parameter to determine whether the inputs are reversed and a second measurement made. This function will remove any voltage offset errors due to the datalogger measurement circuitry, including common mode errors. Enabling this parameter will double measurement time. False (or 0) = Do not make second measurement; True (or 1) = Reverse inputs and make second measurement.

SettlingTime: The SettlingTime parameter is the amount of time to delay after setting up a measurement and before making the measurement. Refer to the table below for default SettlingTimes.

<u>Entry</u>	<u>Range</u>	<u>Integration</u>	<u>Settling Time</u>
0	All	250 μ s	450 μ s (default)
0	All	_50Hz	3 ms (default)
0	All	_60Hz	3 ms (default)
≥ 100	All	All	μ s entered

Integ: The Integ parameter is the amount of time, in microseconds, to integrate a signal for the channel being measured.

<u>Option</u>	<u>Description</u>
250	Performs a 250 microsecond integration.
_60Hz	Performs a 16.667 millisecond integration; filters 60 Hz noise.
_50Hz	Performs a 20 millisecond integration; filters 50 Hz noise.

Mult, Offset: The Mult and Offset parameters are each a constant, variable, array, or expression by which to scale the results of the measurement. With a multiplier (mult) of 1 and an offset of 0, the output is in degrees Celsius.

NOTE The AM25T instruction must NOT be placed in a conditional statement when running in pipeline mode.

6.1.1 Example CRBasic Programs

Both CRBasic example programs are written for CR1000 dataloggers. Other CRBasic dataloggers are programmed similarly.

6.1.1.1 CR1000 Example Program 1

In this example, 25 type T thermocouples are connected to the AM25T. One AM25T instruction will measure the AM25T's PRT and the thermocouples. Table 6-1 shows the wiring used with the example.

TABLE 6-1. Wiring for CR1000 Example 1

Function	AM25T	CR1000
+12V Power	12 V	12 V
Power and Shield Ground	Gnd	Gnd
Clock	CLK	C5
Reset	RES	C4
RTD Excitation	EX	EX1
Common High	HI	1H
Common Low	LO	1L

Example 1. CR1000 Program Using One Instruction to Measure Both the Reference Temperature and Thermocouples

```

'Declare Public Variables
Public Tref
Public TC (25)

'Define Data Tables
DataTable (Dat15sec,1,-1)
    DataInterval (0,15,Sec,10)
    Sample (1,Tref,IEEE4)
    Sample (25,TC(1),IEEE4)
EndTable

DataTable (Dat5min,1,-1)
    DataInterval (0,5,Min,10)
    Average (1,Tref,IEEE4,False)
    Average (25,TC(1),IEEE4,False)
EndTable
    
```

```
'Main Program
BeginProg
  Scan (1,Sec,0,0)
    AM25T (TC(),25,mV2_5C,1,1,TypeT,Tref,5,4,Vx1,True,0,250,1.0,0)
    CallTable Dat15sec
    CallTable Dat5min
  NextScan
EndProg
```

6.1.1.2 CR1000 Example Program 2

In this example, one AM25T instruction is used to measure the on-board PRT, and another AM25T instruction is used to measure ten type T thermocouples. Table 6-2 provides the wiring for the example.

TABLE 6-2. Wiring for CR1000 Example 2

Function	AM25T	CR1000
+12 Power	12 V	12 V
Power and Shield Ground	Gnd	Gnd
Clock	CLK	2
Reset	RES	1
RTD Excitation	EX	EX1
Common High	HI	IH
Common Low	LO	IL

Example 2. CR1000 Program that Uses Separate AM25T Instructions to Measure the PRT and Thermocouples

```
'Declare Variables and Units
Public Batt_Volt
Public RTemp_C
Public Temp_C(10)

Units Batt_Volt=Volts
Units RTemp_C=Deg C
Units Temp_C=Deg C

'Define Data Tables
DataTable(Table1,True,-1)
  DataInterval(0,60,Min,0)
  Sample(10,Temp_C(),FP2)
EndTable

'Main Program
BeginProg
  Scan(30,Sec,1,0)

  'Default Datalogger Battery Voltage measurement Batt_Volt:
  Battery(Batt_Volt)
```

```

'Only the Reference Temperature is measured and stored in RTemp_C.
'To do this, enter 0 for the REP value
AM25T(RTemp_C,0,mV2_5C,1,1,TypeT,RTemp_C,2,1,1,True,0,250,1,0)

'Ten Type T (copper-constantan) are measured on the AM25T.
'Thermocouple measurements are stored in the Temp_C() variable
AM25T(Temp_C(1),10,mV2_5C,1,1,TypeT,RTemp_C,2,1,0,True,0,_60Hz,1,0)
'Call Data Tables and Store Data
CallTable(Table1)
NextScan
EndProg

```

6.2 Edlog Programming

The CR23X uses Instruction 134 for measuring the AM25T. Other Edlog dataloggers use a program that contains a loop in which the multiplexer is advanced to the next channel and the datalogger makes a measurement.

An outline of the looping datalogger program appears below. **Steps two through seven are used to measure the reference temperature for thermocouples and could be skipped for voltage measurements.**

1. Turn on the AM25T
2. Measure the output of the RTD full bridge
3. Find the resistance of the RTD
4. Calculate the reference temperature
5. Pulse the CLK line once (long lead length compensation only)
6. Measure the excitation at the full bridge (long lead length compensation only)
7. Reset the AM25T by pulsing the RES line (long lead length compensation only)
8. Loop through the measurements
 - a) Pulse the CLK line twice
 - b) Measure the sensor
 - c) Convert the engineering units
 - d) Go to a) until all the sensors have been measured
9. Turn off the AM25T

Earlier versions of the AM25T had a zener diode for transient protection on the RTD excitation. This diode limited the negative excitation to -400 mV. Instruction 6 used to measure the RTD uses both a positive and negative excitation voltage. Table 6-3 lists recommended excitation voltages and measurement ranges to use with these early multiplexers. The newer multiplexers will work with the excitation voltages in Table 6-3, but the higher excitations used in the example programs provide more immunity to noise. AM25T multiplexers starting with serial number 1839 allow an excitation voltage up to ± 5000 mV.

Datalogger	Temperature Range	Excitation voltage	Vs Range	Vx Range
21X	-40 to 85°C	250 mV	± 5 mV	± 500 mV
	-24 to 65°C	350 mV	± 5 mV	± 500 mV
CR10(X)	-40 to 85°C	350 mV	± 7.5 mV	± 2500 mV
	-11 to 52°C	250 mV	± 2.5 mV	± 250 mV
CR7	-40 to 85°C	350 mV	± 15 mV	± 500 mV

6.2.1 Example CR10(X) Programs

The two example CR10(X) programs in this section cover measuring thermocouples and low level voltage sensors with the differential measurement instruction. The 21X and CR7 are programmed similarly.

Input locations within the measurement loops must be indexed (--), see Instruction 87 in the datalogger manual. To index a location, using Edlog ver 6.0 or greater, move the cursor to the Input location label and press “F4”. To index a location with the datalogger keyboard, press the “C” key when entering the location number and before the “A” key is pressed.

Function	AM25T	CR10(X)
+12V Power	12 V	12 V
Power and Shield Ground	≡	G
Clock	CLK	C1
Reset	RES	C2
RTD Excitation	EX	E1
Analog Ground	AG	AG
Common High	HI	1H
Common Low	LO	1L

Example 3. CR10(X) Program for Measuring 25 Type T Thermocouples or Voltage Sensors Using a Differential Instruction

```

*Table 1 Program
01: 10           Execution Interval (seconds)

01: Set Port(s) (P20)           ;Configure Control Ports for 1 millisecond pulse
1: 9999           C8..C5 = nc/nc/nc/nc
2: 9933           C4..C1 = nc/nc/1ms/1ms

02: Do (P86)           ;Turn On AM25T
1: 42           Set Port 2 High
    
```

```

03: Full Bridge (P6)                                ;Measure the output of the reference temp. full bridge
1: 1          Reps
2: 23         25 mV 60 Hz Rejection Range  ;See Table 6-1 for older AM25T multiplexers
3: 1          DIFF Channel
4: 1          Excite all reps w/Exchan 1
5: 1200       mV Excitation  ;See Table 6-1 for older AM25T multiplexers
6: 1          Loc [ RefTemp_C ]
7: -0.001     Mult
8: 0.09707    Offset

04: BR Transform Rf[X/(1-X)] (P59)                 ;Calculate RTD resistance R/R0
1: 1          Reps
2: 1          Loc [ RefTemp_C ]
3: 10.025     Multiplier (Rf)

05: Temperature RTD (P16)                          ;Calculate reference temperature
1: 1          Reps
2: 1          R/R0 Loc [ RefTemp_C ]
3: 1          Loc [ RefTemp_C ]
4: 1.0        Mult
5: 0.0        Offset

06: Beginning of Loop (P87)                        ;Loop through thermocouple channels
1: 0          Delay
2: 25         Loop Count

07: Do (P86)                                       ;Clock the AM25T twice
1: 71         Pulse Port 1

08: Do (P86)                                       ;Clock the AM25T twice
1: 71         Pulse Port 1

09: Thermocouple Temp (DIFF) (P14)                ;Measure the connected thermocouple
1: 1          Reps
2: 21         2.5 mV 60 Hz Rejection Range
3: 1          DIFF Channel
4: 1          Type T (Copper-Constantan)
5: 1          Ref Temp (Deg. C) Loc [ RefTemp_C ]
6: 2--       Loc [ TC_1 ]
7: 1.0        Mult
8: 0.0        Offset

10: End (P95)                                      ;End loop

11: Do (P86)                                       ;Turn off AM25T
1: 52         Set Port 2 Low

```

Example 4. CR10(X) Program for Measuring 25 Type T Thermocouples with the Differential Thermocouple Instruction and Long Lead Length Compensation on the RTD Measurement

*Table 1 Program		
01:	10	Execution Interval (seconds)
01:	Set Port(s) (P20)	<i>;Configure Control Ports for 1 millisecond pulse</i>
1:	9999	C8..C5 = nc/nc/nc/nc
2:	9933	C4..C1 = nc/nc/1ms/1ms
02:	Do (P86)	
1:	42	Set Port 2 High <i>;Turn On AM25T</i>
03:	Full Bridge (P6)	<i>;Measure the output of the reference temp. full bridge, Vs</i>
1:	1	Reps
2:	23	25 mV 60 Hz Rejection Range <i>;See Table 6-1 for older AM25T multiplexers</i>
3:	1	DIFF Channel
4:	1	Excite all reps w/Exchan 1
5:	1200	mV Excitation <i>;See Table 6-1 for older AM25T multiplexers</i>
6:	27	Loc [Vs]
7:	1	Mult
8:	0	Offset
04:	Do (P86)	<i>;Clock to advance to measure excitation</i>
1:	71	Pulse Port 1
05:	Full Bridge (P6)	<i>;Measure the Excitation at the full bridge, Vx</i>
1:	1	Reps
2:	25	2500 mV 60 Hz Rejection Range <i>;See Table 6-1 for older AM25T multiplexers</i>
3:	1	DIFF Channel
4:	1	Excite all reps w/Exchan 1
5:	1200	mV Excitation <i>;See Table 6-1 for older AM25T multiplexers</i>
6:	28	Loc [Vx]
7:	.001	Mult
8:	0	Offset
06:	Z=X/Y (P38)	<i>;Calculate Vs/Vx</i>
1:	27	X Loc [Vs]
2:	28	Y Loc [Vx]
3:	1	Z Loc [RefTemp_C]
07:	Z=X*F (P37)	
1:	1	X Loc [RefTemp_C]
2:	-0.001	F
3:	1	Z Loc [RefTemp_C]
08:	Z=X+F (P34)	
1:	1	X Loc [RefTemp_C]
2:	.09707	F
3:	1	Z Loc [RefTemp_C]

```

09: BR Transform Rf[X/(1-X)] (P59)      ;Calculate RTD resistance R/R0
    1: 1          Reps
    2: 1          Loc [ RefTemp_C ]
    3: 10.025    Multiplier (Rf)

10: Temperature RTD (P16)              ;Calculate reference temperature
    1: 1          Reps
    2: 1          R/R0 Loc [ RefTemp_C ]
    3: 1          Loc [ RefTemp_C ]
    4: 1.0        Mult
    5: 0.0        Offset

11: Do (P86)                           ;Reset multiplexer
    1: 72          Pulse Port 2

12: Beginning of Loop (P87)           ;Loop through thermocouple channels
    1: 0          Delay
    2: 25         Loop Count

13: Do (P86)                           ;Clock the AM25T twice
    1: 71          Pulse Port 1

14: Do (P86)
    1: 71          Pulse Port 1

15: Thermocouple Temp (DIFF) (P14)    ;Measure the connected thermocouple
    1: 1          Reps
    2: 21         2.5 mV 60 Hz Rejection Range
    3: 1          DIFF Channel
    4: 1          Type T (Copper-Constantan)
    5: 1          Ref Temp (Deg. C) Loc [ RefTemp_C ]
    6: 2--       Loc [ TC_1 ]
    7: 1.0        Mult
    8: 0.0        Offset

16: End (P95)                          ;End loop

17: Do (P86)                            ;Turn off AM25T
    1: 52          Set Port 2 Low

```

6.2.2 Example CR23X Program

The CR23X uses Instruction 134 for measuring thermocouples or voltages with the AM25T. Example 5 is a portion of a datalogger program that uses the instruction to measure 25 type T thermocouples. Instruction 134 automatically compensates for long lead lengths.

TABLE 6-5. Wiring for CR23X Example		
Function	AM25T	CR23X
+12V Power	12 V	12 V
Power and Shield Ground	≡	G
Clock	CLK	C1
Reset	RES	C2
RTD Excitation	EX	E1
Analog Ground	AG	≡
Common High	HI	1H
Common Low	LO	1L

Example 5. CR23X Program for Measuring 25 Type T Thermocouples

```

;{CR23X}
;
*Table 1 Program
 01: 1      Execution Interval (seconds)

01: AM25TMultiplexer (P134)
 1: 25      Reps
 2: 21      10 mV, 60 Hz Reject, Slow Range
 3: 1       AM25T Channel
 4: 1       DIFF Channel
 5: 21      Exchan 1, 60 Hz Reject
 6: 1       Clock Control
 7: 2       Reset Control
 8: 1       Type T (Copper-Constantan)
 9: 1       Ref Temp (Deg. C) Loc [ RefTemp ]
10: 2       Loc [ TC_1 ]
11: 1.0     Mult
12: 0.0     Offset
    
```

Appendix A. Single-Ended Measurements

Single-ended measurements with the AM25T are not recommended. This is not due to any problem with the AM25T. Single-ended measurements have some problems that differential measurements avoid. The problems with single-ended measurements are:

- *Reduced noise rejection.*
- *Ground reference and Ground Loops.*

A differential voltage measurement measures the voltage difference between two inputs. Current is not allowed to flow through either input. A single-ended voltage measurement measures the voltage of an input with respect to datalogger ground. Current can flow to ground if there is a voltage potential to drive it. When current is flowing, the voltage will change along the current path. For example, if a thermocouple's measurement junction is in electrical contact with a point on a car that is at +1 millivolt with respect to datalogger ground, that voltage will be added to the thermocouple's output, about a 2.5 degree error on a copper-constantan thermocouple. Likewise, current flowing through the datalogger's ground can cause the ground reference to vary slightly along the terminal strip.

Despite the shortcomings, single-ended voltage measurements are possible with the AM25T.

A.1 Directions for Single-Ended Measurements

If single-ended measurements are required, take the following precautions.

1. Use only shielded wire (this advice is just as pertinent for differential measurements). Tie the sensor shields to the datalogger earth ground through the multiplexer's ground terminals.
2. Electrically insulate the measurement junctions of thermocouples. This must be done to avoid errors caused by different ground potentials.
3. With a CR10(X), connect the AM25T ground to analog ground (AG) instead of ground (G). Make sure any other power returns are connected to ground (G).

CAUTION

When making single-ended measurements with a 21X, power the AM25T, and any other peripherals, with a separate power supply. Connect a single wire between a 21X ground and the negative terminal of the external battery.

A.1.1 Thermocouple Measurements

Wire the high side of each thermocouple into an input terminal. The low side of each thermocouple is wired into the adjacent ground terminal (Figure A-1).

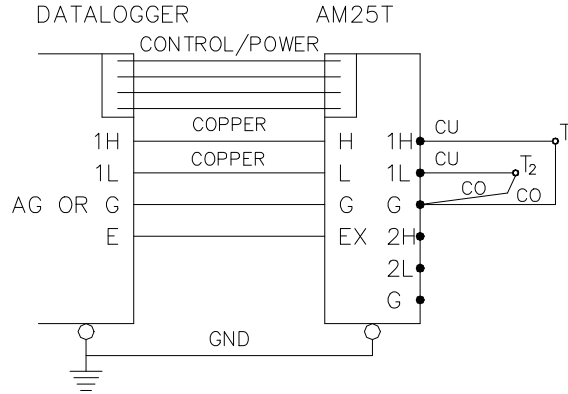

FIGURE A-1. Single-ended Measurement of a Type T Thermocouple

Example A-1. CR10 Program for Measuring 50 Type T Thermocouples or Voltage Sensors Using a Single-Ended Instruction

```

*Table 1 Program
01: 10           Execution Interval (seconds)

01: Set Port(s) (P20)           ;Configure Control Ports for 1 millisecond pulse
1: 9999           C8..C5 = nc/nc/nc/nc
2: 9933           C4..C1 = nc/nc/1ms/1ms

02: Do (P86)           ;Turn On AM25T
1: 42           Set Port 2 High

03: Full Bridge (P6)           ;Measure the output of the reference temp. full bridge
1: 1           Reps
2: 24           250 mV 60 Hz Rejection Range ;See Table 6-1 for older AM25T multiplexers
3: 1           DIFF Channel
4: 1           Excite all reps w/Exchan 1
5: 1200         mV Excitation           ;See Table 6-1 for older AM25T multiplexers
6: 1           Loc [ RefTemp_C ]
7: -0.001       Mult
8: 0.09707      Offset

04: BR Transform Rf[X/(1-X)] (P59) ;Calculate RTD resistance R/R0
1: 1           Reps
2: 1           Loc [ RefTemp_C ]
3: 10.025       Multiplier (Rf)
    
```

```

05: Temperature RTD (P16)                ;Calculate reference temperature
   1: 1      Reps
   2: 1      R/R0 Loc [ RefTemp_C ]
   3: 1      Loc [ RefTemp_C ]
   4: 1.0    Mult
   5: 0.0    Offset

06: Beginning of Loop (P87)              ;Loop through thermocouple channels
   1: 0      Delay
   2: 25     Loop Count

07: Step Loop Index (P90)                ;Set index to advance 2 locations/loop
   1: 2      Step

08: Do (P86)                             ;Clock the AM25T twice
   1: 71     Pulse Port 1

09: Do (P86)
   1: 71     Pulse Port 1

10: Thermocouple Temp (SE) (P13)         ;Measure the connected thermocouple
   1: 2      Reps
   2: 21     2.5 mV 60 Hz Rejection Range
   3: 1      SE Channel
   4: 1      Type T (Copper-Constantan)
   5: 1      Ref Temp (Deg. C) Loc [ RefTemp_C ]
   6: 2--    Loc [ TC_1 ]
   7: 1.0    Mult
   8: 0.0    Offset

11: End (P95)                            ;End loop

12: Do (P86)                             ;Turn off AM25T
   1: 52     Set Port 2 Low

```

Example A-2. 21X Program for Measuring 50 Type T Thermocouples or Voltage Sensors Using a Single-ended Instruction

```

*Table 1 Program
01: 10      Execution Interval (seconds)

01: Do (P86)                             ;Turn On AM25T
   1: 42     Set Port 2 High

02: Full Bridge (P6)                     ;Measure the output of the reference temp. full bridge
   1: 1      Reps
   2: 3      50 mV Slow Range             ;See Table 6-1 for older AM25T multiplexers
   3: 1      DIFF Channel
   4: 1      Excite all reps w/Exchan 1
   5: 2400   mV Excitation                 ;See Table 6-1 for older AM25T multiplexers
   6: 1      Loc [ RefTemp_C ]
   7: -0.001 Mult
   8: 0.09707 Offset

```

```

03: BR Transform Rf[X/(1-X)] (P59)      ;Calculate RTD resistance R/R0
    1: 1          Reps
    2: 1          Loc [ RefTemp_C ]
    3: 10.025     Multiplier (Rf)

04: Temperature RTD (P16)              ;Calculate reference temperature
    1: 1          Reps
    2: 1          R/R0 Loc [ RefTemp_C ]
    3: 1          Loc [ RefTemp_C ]
    4: 1.0        Mult
    5: 0.0        Offset

05: Beginning of Loop (P87)           ;Loop through thermocouple channels
    1: 0          Delay
    2: 25         Loop Count

06: Step Loop Index (P90)             ;Set index to advance 2 locations/loop
    1: 2          Step

07: Do (P86)                          ;Clock the AM25T twice
    1: 41         Set Port 1 High      ;Setting high then low is faster than pulsing w/21X

08: Do (P86)
    1: 51         Set Port 1 Low

09: Do (P86)
    1: 41         Set Port 1 High

10: Do (P86)
    1: 51         Set Port 1 Low

11: Thermocouple Temp (SE) (P13)      ;Measure the connected thermocouples
    1: 2          Reps
    2: 1          5 mV Slow Range
    3: 1          SE Channel
    4: 1          Type T (Copper-Constantan)
    5: 1          Ref Temp (Deg. C) Loc [ RefTemp_C ]
    6: 2--        Loc [ TC_1 ]
    7: 1.0        Mult
    8: 0.0        Offset

12: End (P95)                         ;End of loop

13: Do (P86)                          ;Turn off AM25T
    1: 52         Set Port 2 Low

```

A.1.2 Single-Ended Voltage Measurement

Connect two single-end sensors to the differential AM25T input channel. Connect the sensor shields to the ground terminals next to the input channel. Up to 50 single-ended voltage sensors may be measured by two single-ended datalogger channels (Figure A-2).

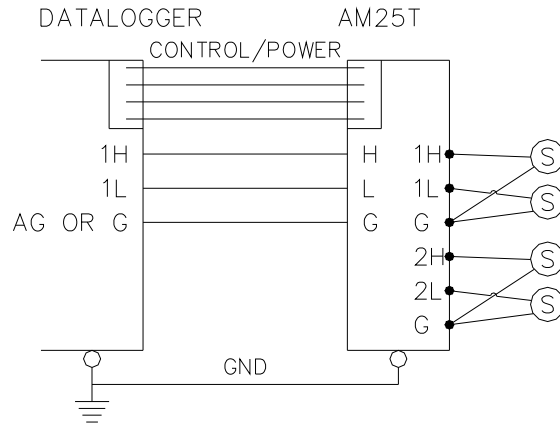

FIGURE A-2. Single-Ended Measurement

A.2 Indexing with Loops

When a multiplexer is measured with a measurement instruction within a loop, the input locations in which to store measurements must be indexed to the loop counter so the measurement is stored in the next input location each pass through the loop. When more than one repetition is used on the measurement instruction, as in examples A-1 and A-2, Instruction 90 is used to set the increment of the loop index. With Instruction 90 correctly used, each measurement will occupy its own input location, without being overwritten by subsequent passes through the loop.

Take the following measurement case. Six Type T thermocouples are measured with a CR10 and AM25T. The thermocouples are wired into the AM25T as shown in Figure A-1. Instruction 13, with two repetitions, is used to measure the thermocouples inside a loop. With a Loop Count of three and no indexing on the thermocouple location (Example A-3), the measurements would be stored in Input Storage as shown in Table A-1.

Note that after the third pass through the loop, only the last two measurements are in Input Storage. The temperatures for TC_1 through TC_4 have been overwritten.

NOTE

The multiplexer control instructions are not included in the example program fragment.

Pass	18	19	20	21	22	23
First	TC_1	TC_2				
Second	TC_3	TC_4				
Third	TC_5	TC_6				

When the Input Location is indexed (see Instruction 87 in the datalogger manual), the Loop Index counter is added to the specified input location, each pass through the loop, to determine where the measurement is stored. By default, the index advances by one with each pass through the loop. Simply indexing a measurement instruction's Input Location works, when the

instruction has one repetition. If the instruction has two repetitions, then every other Input Location will be over written. This effect is illustrated in Table A-2. The program fragment in Example A-4 generated this effect.

NOTE The multiplexer control instructions are not included in the example program fragment.

Pass	18	19	20	21	22	23
First	TC_1	TC_2				
Second		TC_3	TC_4			
Third			TC_5	TC_6		

By adding Instruction 90 (Step Loop Index) with a value of two, the measurements will be stored sequential in Input Storage. See Table A-3 and the program fragment in Example A-5.

NOTE The multiplexer control instructions are not included in the example program fragment.

Pass	18	19	20	21	22	23
First	TC_1	TC_2				
Second			TC_3	TC_4		
Third					TC_5	TC_6

Example A-3. Single Ended Thermocouples, Input Location Not Indexed

01: Beginning of Loop (P87)	
1:	0 Delay
2:	6 Loop Count
02: Thermocouple Temp (SE) (P13)	
1:	2 Reps
2:	21 2.5 mV 60 Hz Rejection Range
3:	1 SE Channel
4:	1 Type T (Copper-Constantan)
5:	1 Ref Temp (Deg. C) Loc [RefTemp]
6:	18 Loc [TC_1]
7:	1.0 Mult
8:	0.0 Offset
03: End (P95)	

Example A-4. Measuring Single Ended Thermocouples with the Input Location Indexed and no Step Loop Index

```

01: Beginning of Loop (P87)
    1: 0    Delay
    2: 6Loop Count

02: Thermocouple Temp (SE) (P13)
    1: 2      Reps
    2: 21     2.5 mV 60 Hz Rejection Range
    3: 1      SE Channel
    4: 1      Type T (Copper-Constantan)
    5: 1      Ref Temp (Deg. C) Loc [ RefTemp ]
    6: 18--   Loc [ TC_1   ]
    7: 1.0    Mult
    8: 0.0    Offset

03: End (P95)

```

Example A-5. Measuring Single Ended Thermocouples with the Input Location Indexed and Step Loop Index

```

01: Beginning of Loop (P87)
    1: 0      Delay
    2: 6      Loop Count

02: Step Loop Index (P90)
    1: 2      Step

03: Thermocouple Temp (SE) (P13)
    1: 2      Reps
    2: 21     2.5 mV 60 Hz Rejection Range
    3: 1      SE Channel
    4: 1      Type T (Copper-Constantan)
    5: 1      Ref Temp (Deg. C) Loc [ RefTemp ]
    6: 18--   Loc [ TC_1   ]
    7: 1.0    Mult
    8: 0.0    Offset

04: End (P95)

```

Appendix B. Differences Between the AM25T, AM416, and the AM32

The AM25T differs from Campbell Scientific's AM416 and AM32 multiplexers in the following ways:

1. The AM25T cannot be used to multiplex power and is not suitable for bridge measurements because of the high impedance of the solid state relays.
2. The AM25T switches 25 sets of 2 lines at a time, (HI and LO) (2 x 25), unlike the AM416 which switches 16 sets of 4 lines at a time (4 x 16). The AM32 switches 32 sets of 2 lines at a time (2 x 32).
3. The AM25T has a built-in temperature reference RTD for thermocouple measurements. It is 1000 Ohm RTD and has a temperature specification of $\pm 0.2^{\circ}\text{C}$ and an α of 0.00385.
4. The AM25T is packaged in an aluminum case that will decrease temperature gradients across the multiplexer terminal strip. It has a large aluminum bar through the center of the unit for temperature stabilization and sensor cable strain relief.
5. The AM25T is smaller than the AM416 and AM32. It is packaged in a vertical manner for a smaller footprint and requires less space for mounting.
6. The AM25T has a ground path back to the datalogger for spark gap firing and sensor shields via the grounding lug on the side. The AM25T contains terminals and circuitry for sensor shield wires. This circuitry allows sensor shield wires to be routed through the multiplexer and grounded at the datalogger.
7. The AM25T contains spark gaps on all inputs and like the AM416 contains diodes between shields and power ground for transient protection.

Campbell Scientific Companies

Campbell Scientific, Inc. (CSI)

815 West 1800 North
Logan, Utah 84321
UNITED STATES
www.campbellsci.com • info@campbellsci.com

Campbell Scientific Africa Pty. Ltd. (CSAf)

PO Box 2450
Somerset West 7129
SOUTH AFRICA
www.csafrica.co.za • cleroux@csafrica.co.za

Campbell Scientific Australia Pty. Ltd. (CSA)

PO Box 444
Thuringowa Central
QLD 4812 AUSTRALIA
www.campbellsci.com.au • info@campbellsci.com.au

Campbell Scientific do Brazil Ltda. (CSB)

Rua Luisa Crapsi Orsi, 15 Butantã
CEP: 005543-000 São Paulo SP BRAZIL
www.campbellsci.com.br • suporte@campbellsci.com.br

Campbell Scientific Canada Corp. (CSC)

11564 - 149th Street NW
Edmonton, Alberta T5M 1W7
CANADA
www.campbellsci.ca • dataloggers@campbellsci.ca

Campbell Scientific Centro Caribe S.A. (CSCC)

300 N Cementerio, Edificio Breller
Santo Domingo, Heredia 40305
COSTA RICA
www.campbellsci.cc • info@campbellsci.cc

Campbell Scientific Ltd. (CSL)

Campbell Park
80 Hathern Road
Shepshed, Loughborough LE12 9GX
UNITED KINGDOM
www.campbellsci.co.uk • sales@campbellsci.co.uk

Campbell Scientific Ltd. (France)

Miniparc du Verger - Bat. H
1, rue de Terre Neuve - Les Ulis
91967 COURTABOEUF CEDEX
FRANCE
www.campbellsci.fr • info@campbellsci.fr

Campbell Scientific Spain, S. L.

Psg. Font 14, local 8
08013 Barcelona
SPAIN
www.campbellsci.es • info@campbellsci.es

Please visit www.campbellsci.com to obtain contact information for your local US or International representative.