

INSTRUCTION MANUAL

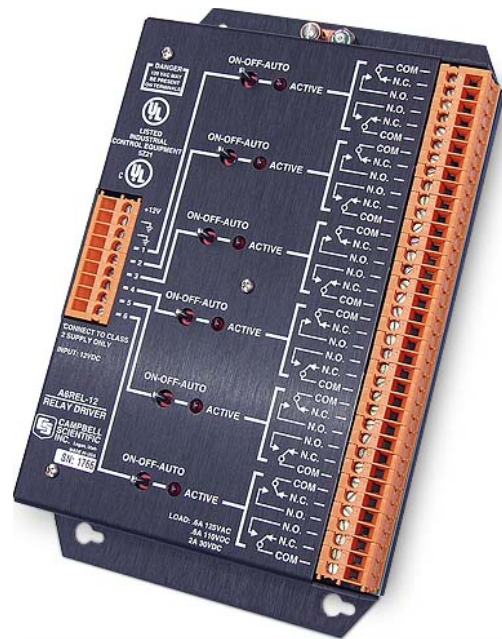

A6REL-12 Relay Driver

Revision: 7/09



Copyright © 1985-2009
Campbell Scientific, Inc.

WARRANTY AND ASSISTANCE

This equipment is warranted by CAMPBELL SCIENTIFIC (CANADA) CORP. ("CSC") to be free from defects in materials and workmanship under normal use and service for **twelve (12) months** from date of shipment unless specified otherwise. **** **Batteries are not warranted.** **** CSC's obligation under this warranty is limited to repairing or replacing (at CSC's option) defective products. The customer shall assume all costs of removing, reinstalling, and shipping defective products to CSC. CSC will return such products by surface carrier prepaid. This warranty shall not apply to any CSC products which have been subjected to modification, misuse, neglect, accidents of nature, or shipping damage. This warranty is in lieu of all other warranties, expressed or implied, including warranties of merchantability or fitness for a particular purpose. CSC is not liable for special, indirect, incidental, or consequential damages.

Products may not be returned without prior authorization. To obtain a Return Merchandise Authorization (RMA), contact CAMPBELL SCIENTIFIC (CANADA) CORP., at (780) 454-2505. An RMA number will be issued in order to facilitate Repair Personnel in identifying an instrument upon arrival. Please write this number clearly on the outside of the shipping container. Include description of symptoms and all pertinent details.

CAMPBELL SCIENTIFIC (CANADA) CORP. does not accept collect calls.

Non-warranty products returned for repair should be accompanied by a purchase order to cover repair costs.



CAMPBELL SCIENTIFIC
C A N A D A C O R P .

11564 - 149 street - edmonton - alberta - T5M 1W7
tel 780.454.2505 fax 780.454.2655

www.campbellsci.ca

PLEASE READ FIRST

About this manual

Please note that this manual was originally produced by Campbell Scientific Inc. (CSI) primarily for the US market. Some spellings, weights and measures may reflect this origin.

Some useful conversion factors:

Area: 1 in² (square inch) = 645 mm²

Length: 1 in. (inch) = 25.4 mm
1 ft (foot) = 304.8 mm
1 yard = 0.914 m
1 mile = 1.609 km

Mass: 1 oz. (ounce) = 28.35 g
1 lb (pound weight) = 0.454 kg

Pressure: 1 psi (lb/in²) = 68.95 mb

Volume: 1 US gallon = 3.785 litres

In addition, part ordering numbers may vary. For example, the CABLE5CBL is a CSI part number and known as a FIN5COND at Campbell Scientific Canada (CSC). CSC Technical Support will be pleased to assist with any questions.

A6REL-12 Table of Contents

PDF viewers note: These page numbers refer to the printed version of this document. Use the Adobe Acrobat® bookmarks tab for links to specific sections.

1. Function	1
2. Specifications	3
3. Powering the A6REL-12	3
4. Installation	4
5. Example Programs	4
5.1 CRBasic	5
5.2 EDLOG.....	6

Figures

1. A6REL-12 Panel View	1
2. Position of Contacts When Coil IS Energized (ON)	2
3. Position of Contacts When Coil IS NOT Energized (OFF).....	2

Table

1. Recommended Cables to Control Relays	4
---	---

A6REL-12 Relay Driver

1. Function

The A6REL-12 (Figure 1) drives six dual single pole double throw internal relays for control of up to 12 external AC or DC devices. Each of the six relays has a three position toggle switch; "on" and "off" for manual override, and "auto" for datalogger control. In the on position, the common and normally open contacts are shorted (Figures 2 and 3). In the auto position, the state of a relay is controlled by a datalogger control port.

Please note that the A6REL-12 is not compatible with our CR200-series dataloggers.

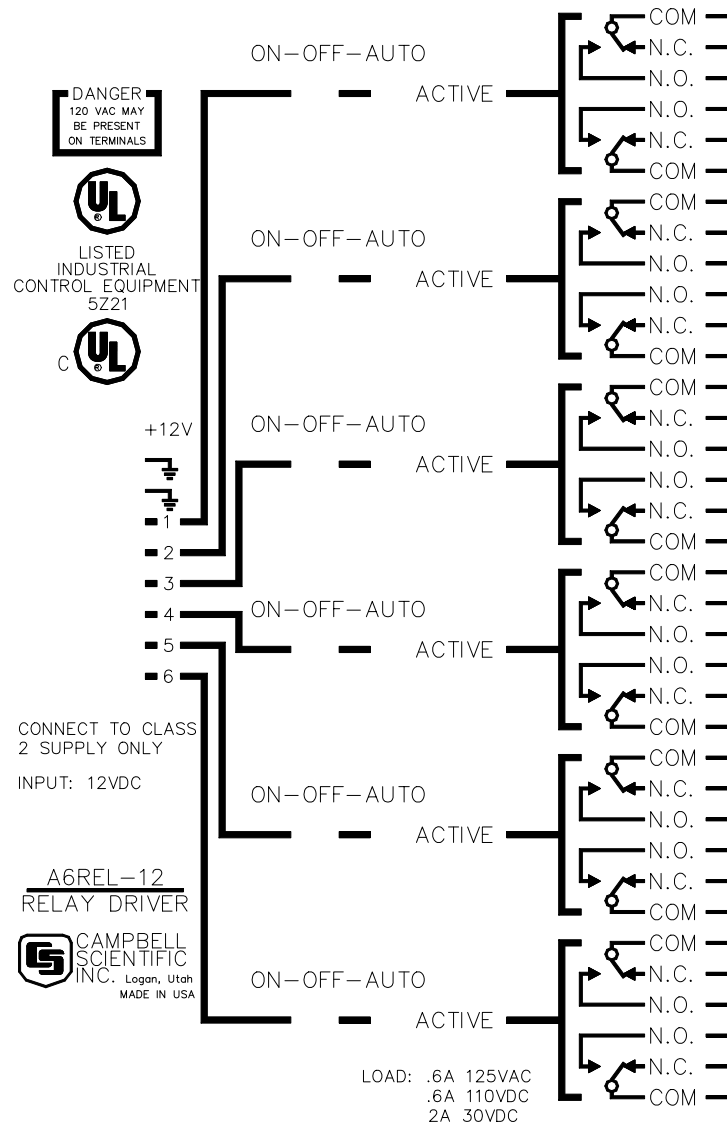

FIGURE 1. A6REL-12 Panel View

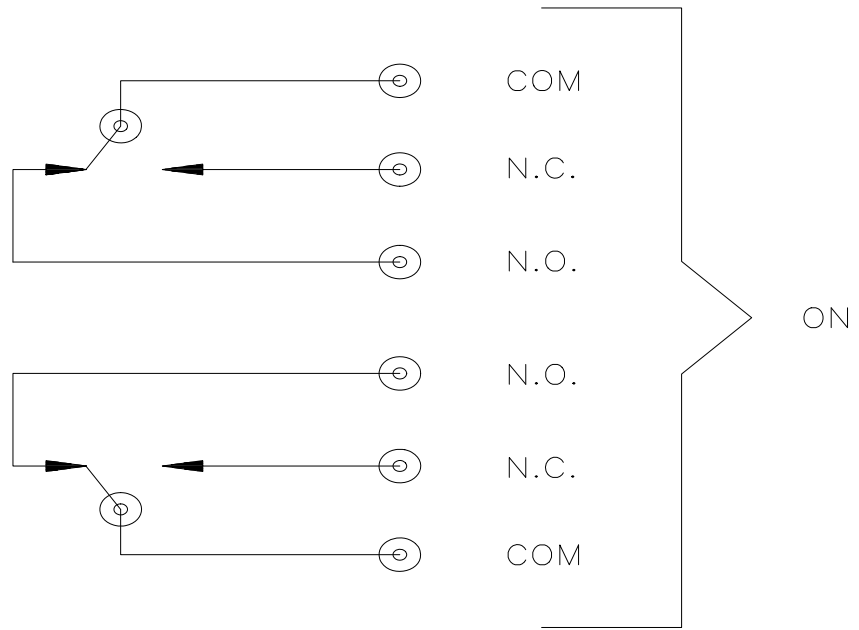

FIGURE 2. Position of Contacts When Coil IS Energized (ON)

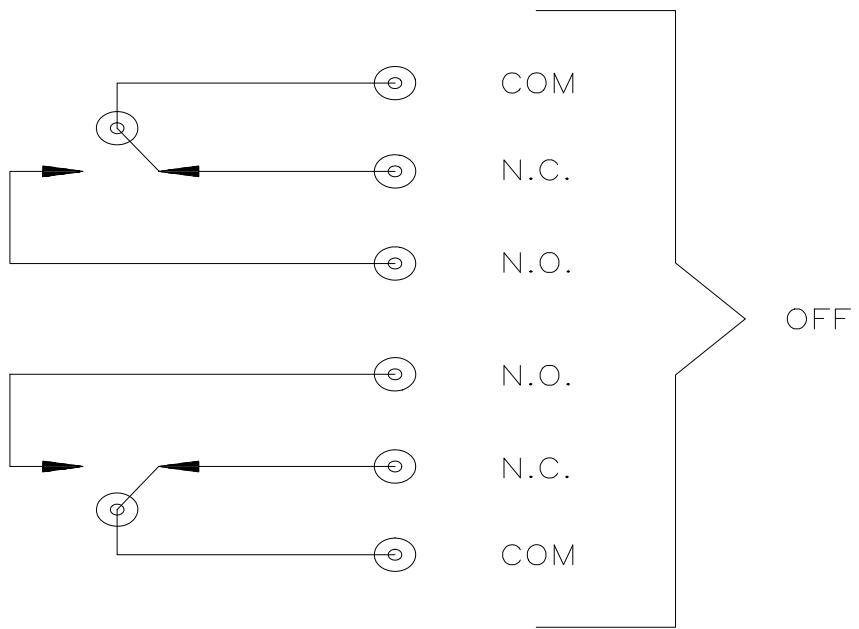

FIGURE 3. Position of Contacts When Coil IS NOT Energized (OFF)

2. Specifications

Operating voltage:	12 VDC nominal (8.4 to 24)
Current drain at 12 VDC:	6 μ A quiescent; 30 mA per active LED (switch ON or AUTO active).
Toggle Switch:	ON/OFF manual override; AUTO for datalogger control.

Underwriters Laboratories (UL) and Canadian Underwriters Laboratories (CUL) listed product. UL and CUL listing number is 5Z21.

RELAY SPECIFICATIONS

Arrangement:	Dual single pole double throw Break before make
Contact material:	Gold-clad silver
Individual contact rating:	2A at 30 VDC 0.6A at 125 VAC
Coil voltage:	8.4 to 24 VDC
Coil resistance:	720 Ohms \pm 10%
Expected life (contact closures):	
Mechanical	10 ⁸
Electrical	2A at 30 VDC 5x10 ⁵ 1A at 30 VDC 2x10 ⁶
Actuation/release time:	Approx. 3 ms
Operating temperature:	-40° to 70°C

NOTE

The A6REL-12 protects each contact against voltage surges of 180 VDC (130 V rms) or greater with a power content of 8 Watts maximum and maximum duration of 0.1 ms.

3. Powering the A6REL-12

The A6REL-12 may be powered by the datalogger power supply or a separate 8.4 to 24 VDC battery.

If the 21X power supply is used to power the A6REL-12, all low level analog measurements (thermocouples, pyranometers, thermopiles, etc.) must be made differentially. This is a result of slight ground potentials created along the 21X analog terminal strip when the 12 volt supply is used to power peripherals. This limitation reduces the number of available analog channels and may require the use of a separate battery to power the A6REL-12.

4. Installation

The A6REL-12 relay driver includes mounting flanges with keyhole slots that attach to the backplate of a Campbell Scientific enclosure.

The A6REL-12 must be in an enclosure that provides a pollution degree 2 environment (normally, only nonconductive pollution. However, a temporary conductivity caused by condensation may be expected). All Campbell Scientific enclosures meet this requirement.

Table 1 shows the cables recommended for connecting the relays. A two-foot length should be sufficient if the datalogger and A6REL-12 are housed in the same enclosure. Tightening torque should be 4.5 in/lb. A user-supplied cable can be used if the cable has:

- only copper conductors
- wire range of 26 to 14 AWG
- minimum 60/75 degree C wire

Input power must be connected to a class 2 supply only. All Campbell Scientific power supplies meet the class 2 supply requirements.

TABLE 1. Recommended Cables to Control Relays	
Number of Relays Controlled	Recommended Cable(s)
1	(1) CABLE3CBL-L
2	(1) CABLE4CBL-L
3	(1) CABLE5CBL-L
4	(2) CABLE3CBL-L
5	(1) CABLE3CBL-L and (1) CABLE4CBL-L
6	(2) CABLE4CBL-L

5. Example Programs

In the following programming examples, temperature is being controlled between 96° and 99°F. A copper-constantan thermocouple is measured to determine the temperature. If the temperature drops below 96 degrees, control port 1 is set high to activate the associated relay and turn the heater on. If the temperature equals or exceeds 99°F, control port 1 is set low to turn the heater off.

5.1 CRBasic

Although the following example is a CR1000 program, other dataloggers that use CRBasic such as the CR800 and CR3000 are programmed similarly.

```
'CR1000 Series Datalogger

'Declare Public Variables
Public PTemp, batt_volt, P, TC

'Define Data Tables
DataTable (Test,1,-1)
    DataInterval (0,15,Sec,10)
    Minimum (1,batt_volt,FP2,0,False)
    Sample (1,PTemp,FP2)
    Sample (1,TC,FP2)

EndTable

'Main Program
BeginProg
    Scan (5,Sec,0,0)
        Battery (Batt_volt)
        'Measure TC reference temperature
        PanelTemp (PTemp,250)
        'Make temperature measurement and convert it to degrees Fahrenheit
        TCDiff (TC,1,mV2_5C,1,TypeT,PTemp,True ,0,250,1.8,32)
        'If temperature is greater than 99 set Port low
        If TC>99 then
            P=0
            'If temperature is less than 96 set Port high
            ElseIf TC<96 then
                P=1
            EndIf
        PortSet (1 ,P)
        'Call Output Tables
        'Example:
        CallTable Test
    NextScan
EndProg
```

5.2 EDLOG

Although the following example is a 21X program, other dataloggers that use Edlog such as the CR10(X) and CR23X are programmed similarly.

*1 Table 1 Program		
01: 5	Sec. Execution Interval	
1: Panel Temperature (P17)		
1:	1	<i>Measure the TC Loc [:REF TEMP] reference temperature</i>
2: Thermocouple Temp (DIFF) (P14)		
1:	1	<i>Rep Measure</i>
2:	1	<i>5 mV slow Range temperature</i>
3:	1	<i>IN Chan</i>
4:	1	<i>Type T (Copper-Constantan)</i>
5:	1	<i>Ref Temp Loc REF TEMP</i>
6:	2	<i>Loc [:TEMP]</i>
7:	1.8	<i>Mult</i>
8:	32	<i>Offset</i>
3: If X<=>F (P89)		
1:	2	<i>X Loc TEMP If temp is greater than or equal to</i>
2:	3	<i>>= 99, set Flag 1 low</i>
3:	99	<i>F</i>
4:	21	<i>Reset flag 1</i>
4: If X<=>F (P89)		
1:	2	<i>X Loc TEMP If temp is less than 96, set</i>
2:	4	<i>< Flag 1 high</i>
3:	96	<i>F</i>
4:	11	<i>Set flag 1</i>
5: Set Port (P20)		
1:	11	<i>Set according to flag 1</i>
2:	1	<i>Port Number according to Flag 1</i>
Input Location Labels:		
1:REF TEMP	2:TEMP	

Campbell Scientific Companies

Campbell Scientific, Inc. (CSI)

815 West 1800 North
Logan, Utah 84321
UNITED STATES
www.campbellsci.com • info@campbellsci.com

Campbell Scientific Africa Pty. Ltd. (CSAf)

PO Box 2450
Somerset West 7129
SOUTH AFRICA
www.csafrica.co.za • cleroux@csafrica.co.za

Campbell Scientific Australia Pty. Ltd. (CSA)

PO Box 444
Thuringowa Central
QLD 4812 AUSTRALIA
www.campbellsci.com.au • info@campbellsci.com.au

Campbell Scientific do Brazil Ltda. (CSB)

Rua Luisa Crapsi Orsi, 15 Butantã
CEP: 005543-000 São Paulo SP BRAZIL
www.campbellsci.com.br • suporte@campbellsci.com.br

Campbell Scientific Canada Corp. (CSC)

11564 - 149th Street NW
Edmonton, Alberta T5M 1W7
CANADA
www.campbellsci.ca • dataloggers@campbellsci.ca

Campbell Scientific Centro Caribe S.A. (CSCC)

300 N Cementerio, Edificio Breller
Santo Domingo, Heredia 40305
COSTA RICA
www.campbellsci.cc • info@campbellsci.cc

Campbell Scientific Ltd. (CSL)

Campbell Park
80 Hathern Road
Shepshed, Loughborough LE12 9GX
UNITED KINGDOM
www.campbellsci.co.uk • sales@campbellsci.co.uk

Campbell Scientific Ltd. (France)

Miniparc du Verger - Bat. H
1, rue de Terre Neuve - Les Ulis
91967 COURTABOEUF CEDEX
FRANCE
www.campbellsci.fr • info@campbellsci.fr

Campbell Scientific Spain, S. L.

Psg. Font 14, local 8
08013 Barcelona
SPAIN
www.campbellsci.es • info@campbellsci.es

Please visit www.campbellsci.com to obtain contact information for your local US or International representative.