

INSTRUCTION MANUAL

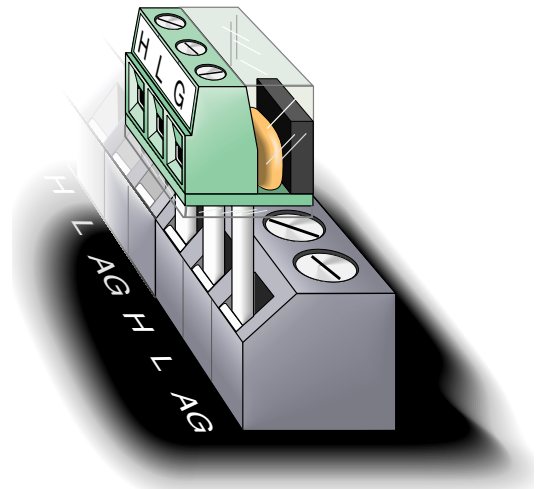

4WPB100, 4WPB1K PRT Bridge Terminal Input Modules

Revision: 12/06



Copyright © 1996-2006
Campbell Scientific, Inc.

WARRANTY AND ASSISTANCE

This equipment is warranted by CAMPBELL SCIENTIFIC (CANADA) CORP. ("CSC") to be free from defects in materials and workmanship under normal use and service for **twelve (12) months** from date of shipment unless specified otherwise. ***** **Batteries are not warranted.** ***** CSC's obligation under this warranty is limited to repairing or replacing (at CSC's option) defective products. The customer shall assume all costs of removing, reinstalling, and shipping defective products to CSC. CSC will return such products by surface carrier prepaid. This warranty shall not apply to any CSC products which have been subjected to modification, misuse, neglect, accidents of nature, or shipping damage. This warranty is in lieu of all other warranties, expressed or implied, including warranties of merchantability or fitness for a particular purpose. CSC is not liable for special, indirect, incidental, or consequential damages.

Products may not be returned without prior authorization. To obtain a Return Merchandise Authorization (RMA), contact CAMPBELL SCIENTIFIC (CANADA) CORP., at (780) 454-2505. An RMA number will be issued in order to facilitate Repair Personnel in identifying an instrument upon arrival. Please write this number clearly on the outside of the shipping container. Include description of symptoms and all pertinent details.

CAMPBELL SCIENTIFIC (CANADA) CORP. does not accept collect calls.

Non-warranty products returned for repair should be accompanied by a purchase order to cover repair costs.



CAMPBELL SCIENTIFIC
C A N A D A C O R P .

11564 - 149 street - edmonton - alberta - T5M 1W7
tel 780.454.2505 fax 780.454.2655

www.campbellsci.ca

4WPB100, 4WPB1K Table of Contents

PDF viewers note: These page numbers refer to the printed version of this document. Use the Adobe Acrobat® bookmarks tab for links to specific sections.

1. Function	1
2. Specifications	1
3. Wiring	2
4. Programming Examples	3
4.1 CR10(X)	5
4.2 21X	5
4.3 CR7	6
4.4 CR9000X.....	6
4.5 CR1000.....	7
5. PRT in 4 Wire Half Bridge	7
5.1 Excitation Voltage	8
5.2 Calibrating a PRT	8

Figures

1-1. Terminal Input Module	1
2-1. Circuit Schematic	2
3-1. Wiring for Example Programs	2

Tables

3-1. 4WPB100/4WPB1K Connections to Campbell Scientific Dataloggers..	3
4-1. Excitation Voltage for 100 Ohm PRT in 4WPB100 Based on Maximum Temperature and Input Voltage Range.....	3
4-2. Excitation Voltage for 1000 Ohm PRT in 4WPB1000 Based on Maximum Temperature and Input Voltage Range.....	4

4WPB100, 4WPB1K PRT Bridge Terminal Input Modules

1. Function

Terminal input modules connect directly to the datalogger's input terminals to provide completion resistors for resistive bridge measurements, voltage dividers, and precision current shunts. The 4WPB100 and 4WPB1K are used to provide completion resistors for 4 wire half bridge measurements of 100 Ohm and 1 kilohm Platinum Resistance Thermometer (PRT), respectively.

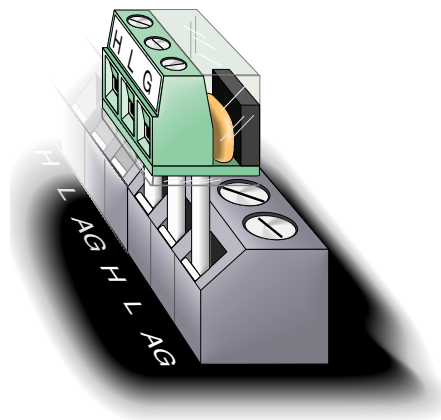

FIGURE 1-1. Terminal Input Module

2. Specifications

Current limiting 10 kOhm Resistor	
Tolerance @ 25 °C	±5%
Power rating	0.25 W
Completion Resistor	
Tolerance @ 25 °C	±0.01%
Temperature coefficient	
0-60 °C	4 ppm/°C
-55-125 °C	8 ppm/°C
Power rating	0.25 W

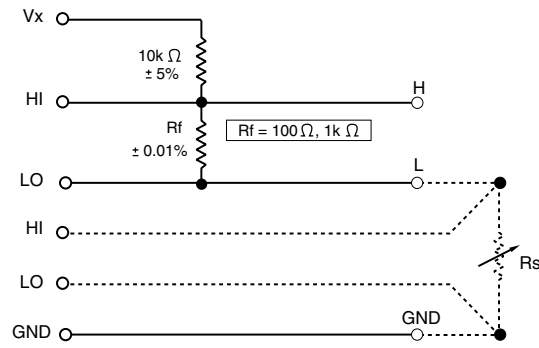

FIGURE 2-1. Circuit Schematic

3. Wiring

The Terminal input module is connected to the appropriate channel. The dashed lines in Figure 2-1 indicate the sensor wiring. When making 4 wire half bridge measurements, the 4WPB is connected to a differential channel and the sense leads from the PRT to the next differential channel. The black excitation wire is connected to the excitation channel. In the following examples the 4WPB is connected to differential channel 1 and the PRT to differential channel 2; the excitation wire is connected to excitation channel 1 (Figure 3-1).

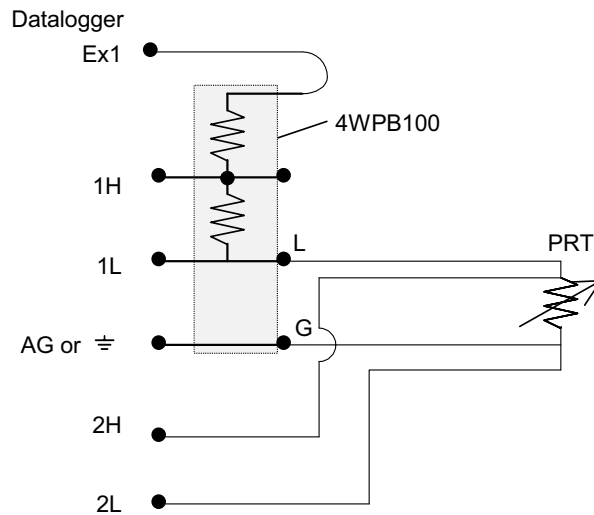

FIGURE 3-1. Wiring for Example Programs

TABLE 3-1. 4WPB100/4WPB1K Connections to Campbell Scientific Dataloggers

Function	Label/Lead	CR10X, CR510	CR23X, CR1000, CR800, CR850, CR3000	21X, CR7, CR9000X
Excitation	Black Wire	E1	EX1	Excitation 1
V1 High	H	1H	1H	1H
V1 Low	L	1L	1L	1L
Ground	G	AG	⊕	⊕

4. Programming Examples

The following examples simply show the two instructions necessary to 1) make the measurement and 2) calculate the temperature. The result of the 4 wire half bridge measurement as shown is R_s/R_o , the input required for the PRT algorithm to calculate temperature. Note that “Full Bridge” is shown as the name for measurement Instruction 9 (used with CR10(X), 21X, and CR7). When Instruction 9 is used with the first measurement range not set to the maximum input range, it becomes a four wire half bridge measurement.

All the examples are for a 100 Ohm PRT in the 4WPB100. The excitation voltages used were chosen with the assumption that the temperature would not exceed 50 °C. Tables 4-1 and 4-2 list excitation voltage as a function of maximum temperature and the input voltage ranges used with the different dataloggers. Calculation of optimum excitation voltage is discussed in Section 5.1.

TABLE 4-1. Excitation Voltage for 100 Ohm PRT in 4WPB100 Based on Maximum Temperature and Input Voltage Range

Max. Temp °C	PRT Resistance Ohms	Excitation Voltage, mV	
		±25 mV Input Range, CR10(X), CR800, CR850, CR1000	±50 mV Range, 21X, CR7, CR3000, CR9000X
50	119.4	2035	4070
100	138.5	1758	3516
150	157.31	1551	3101
200	175.84	1390	2780
250	194.07	1262	2523
300	212.02	1157	2314
350	229.67	1070	2140
400	247.04	997	1993
450	264.11	934	1867
500	280.9	879	1759
550	297.39	832	1664
600	313.59	790	1581

650	329.51	753	1507
700	345.13	720	1441
750	360.47	691	1382
800	375.51	664	1328
850	390.26	640	1280

TABLE 4-2. Excitation Voltage for 1000 Ohm PRT in 4WPB1000 Based on Maximum Temperature and Input Voltage Range

Max. Temp. °C	PRT Resist. Ohms	Excitation Voltage, mV		
		±200 mV Input Range CR9000X	±250 mV Input Range CR10(X), CR1000, CR800, CR850	±500 mV Input Range 21X, CR7, CR3000
50	1194.	1959	2448	4897
100	1385.	1716	2145	4291
150	1573.1	1535	1919	3837
200	1758.4	1394	1743	3486
250	1940.7	1282	1603	3205
300	2120.2	1190	1488	2976
350	2296.7	1114	1393	2786
400	2470.4	1050	1313	2625
450	2641.1	995	1244	2488
500	2809.	948	1184	2369
550	2973.9	906	1133	2265
600	3135.9	870	1087	2174
650	3295.1	837	1047	2093
700	3451.3	808	1011	2021
750	3604.7	783	978	1956
800	3755.1	759	949	1898
850	3902.6	738	923	1845

4.1 CR10(X)

01: Full Bridge w/mv Excit (P9)	
1: 1	Reps
2: 23	± 25 mV 60 Hz Rejection Ex Range
3: 23	± 25 mV 60 Hz Rejection Br Range
4: 1	DIFF Channel
5: 1	Excite all reps w/Exchan 1
6: 2035	mV Excitation
7: 1	Loc [Rs_Ro]
8: 1.0	Mult
9: 0	Offset
02: Temperature RTD (P16)	
1: 1	Reps
2: 1	R/Ro Loc [Rs_Ro]
3: 2	Loc [Temp_C]
4: 1	Mult
5: 0	Offset

4.2 21X

1: Full Bridge w/mv Excit (P9)	
1: 1	Reps
2: 3	± 50 mV Slow Ex Range
3: 3	± 50 mV Slow Br Range
4: 1	DIFF Channel
5: 1	Excite all reps w/Exchan 1
6: 4070	mV Excitation
7: 1	Loc [Rs_Ro]
8: 1.0	Mult
9: 0.0	Offset
2: Temperature RTD (P16)	
1: 1	Reps
2: 1	R/RO Loc [Rs_Ro]
3: 2	Loc [Temp_C]
4: 1.0	Mult
5: 0.0	Offset

4.3 CR7

1: Full Bridge w/mv Excit (P9)		
1:	1	Reps
2:	3	± 15 mV Slow Range
3:	3	± 15 mV Slow Range
4:	1	In Card
5:	1	DIFF Channel
6:	1	Ex Card
7:	1	Ex Channel
8:	1	Meas/Ex
9:	4070	mV Excitation
10:	1	Loc [Rs_Ro]
11:	1.0	Mult
12:	0.0	Offset
2: Temperature RTD (P16)		
1:	1	Reps
2:	1	R/RO Loc [Rs_Ro]
3:	2	Loc [Temp_C]
4:	1.0	Mult
5:	0.0	Offset

4.4 CR9000X

```
'CR9000X Datalogger
Public Rs_Ro, Temp_F

DataTable (Temp_F,1,-1)
  DataInterval (0,0,0,10)
  Sample (1,Temp_F,FP2)
EndTable

BeginProg
Scan (1,mSec,0,0)
BrHalf4W (Rs_Ro,1,mV50,mV50,4,1,5,7,1,4070,True,True,30,40,1.0,0)
  PRT (Temp_F,1,Rs_Ro,1.8,32)
  CallTable Temp_F
  NextScan
EndProg
```

4.5 CR1000

```
'CR1000 Series Datalogger
```

```
Public Rs_R0, Temp_C
```

```
DataTable (Hourly,True,-1)
```

```
    DataInterval (0,60,Min,0)
```

```
    Average (1,Temp_C,IEEE4,0)
```

```
EndTable
```

```
BeginProg
```

```
    Scan (1,Sec,0,0)
```

```
        BrHalf4W (Rs_R0,1,mV25,mV25,1,Vx1,1,2035,True ,True ,0,250,1.0,0)
```

```
        PRT (Temp_C,1,Rs_R0,1.0,0)
```

```
        CallTable Hourly
```

```
    NextScan
```

```
EndProg
```

5. PRT in 4 Wire Half Bridge

A 4 wire half bridge is the best choice for accuracy where the Platinum Resistance Thermometer (PRT) is separated from other bridge completion resistors by a lead length having more than a few thousandths of an Ohm resistance. Four wires to the sensor allow one set of wires to carry the excitation current and a separate set of sense wires that allow the voltage across the PRT to be measured without the effect of any voltage drop in the excitation leads.

Figure 2-1 shows the circuit used to measure the PRT. The 10 kOhm resistor allows the use of a high excitation voltage and low voltage ranges on the measurements. This insures that noise in the excitation does not have an effect on signal noise and that self heating of the PRT due to excitation is kept to a minimum. Because the fixed resistor (R_f) and the PRT (R_s) have approximately the same resistance, the differential measurement of the voltage drop across the PRT can be made on the same range as the differential measurement of the voltage drop across R_f .

The result of the four wire half bridge Instruction is:

$$\frac{V_2}{V_1}$$

the voltage drop is equal to the current (I), times the resistance thus:

$$\frac{V_2}{V_1} = \frac{I \cdot R_s}{I \cdot R_f} = \frac{R_s}{R_f}$$

The RTD Instruction (16) computes the temperature ($^{\circ}\text{C}$) for a DIN 43760 standard PRT from the ratio of the PRT resistance at the temperature being measured (R_s) to its resistance at 0°C (R_0). Thus, a multiplier of R_f/R_0 is used with the 4 wire half bridge instruction to obtain the desired intermediate, $R_s/R_0 = (R_s/R_f \times R_f/R_0)$. If R_f and R_0 are equal, the multiplier is 1.

The fixed resistor must be thermally stable. The 4 ppm/ $^{\circ}\text{C}$ temperature coefficient would result in a maximum error of 0.05°C at 60°C . The 8 ppm/ $^{\circ}\text{C}$ temperature coefficient would result in a maximum error of 0.33°C at 125°C . Because the measurement is ratiometric (R_s/R_f) and does not rely on the absolute values of either R_s or R_f , the properties of the 10 kOhm resistor do not affect the result.

5.1 Excitation Voltage

The best resolution is obtained when the excitation voltage is large enough to cause the signal voltage to fill the measurement voltage range. The voltage drop across the PRT is equal to the current, I , multiplied by the resistance of the PRT, R_s , and is greatest when R_s is greatest. For example, if it is desired to measure a temperature in the range of -10 to 40°C , the maximum voltage drop will be at 40°C when $R_s=115.54$ Ohms. To find the maximum excitation voltage that can be used when the measurement range is ± 25 mV, we assume V_2 equal to 25 mV and use Ohm's Law to solve for the resulting current, I .

$$\begin{aligned} I &= 25 \text{ mV}/R_s = 25 \text{ mV}/115.54 \text{ Ohms} \\ &= 0.216 \text{ mA} \end{aligned}$$

V_x is equal to I multiplied by the total resistance:

$$V_x = I(R_1 + R_s + R_f) = 2.21 \text{ V}$$

If the actual resistances were the nominal values, the 25 mV range would not be exceeded with $V_x = 2.2$ V. To allow for the tolerances in the actual resistances, it is decided to set V_x equal to 2.1 volts (e.g., if the 10 kOhm resistor is 5% low, then $R_s/(R_1 + R_s + R_f) = 115.54/9715.54$, and V_x must be 2.102 V to keep V_s less than 25 mV).

5.2 Calibrating a PRT

The greatest source of error in a PRT is likely to be that the resistance at 0°C deviates from the nominal value. Calibrating the PRT in an ice bath can correct this offset and any offset in the fixed resistor in the Terminal Input Module.

The result of the 4 wire half bridge is:

$$\frac{V_2}{V_1} = \frac{I \cdot R_s}{I \cdot R_f} = \frac{R_s}{R_f}$$

With the PRT at 0 °C, $R_s=R_0$. Thus, the above result becomes R_0/R_f , the reciprocal of the multiplier required to calculate temperature, R_f/R_0 . By making a measurement with the PRT in an ice bath, errors in both R_s and R_0 can be accounted for.

To perform the calibration, connect the PRT to the datalogger and program the datalogger to measure the PRT with the 4 wire half bridge as shown in the example section (multiplier = 1). Place the PRT in an ice bath (@ 0°C; $R_s=R_0$). Read the result of the bridge measurement. The reading is R_s/R_f , which is equal to R_0/R_f since $R_s=R_0$. The correct value of the multiplier, R_f/R_0 , is the reciprocal of this reading. For example, if the initial reading is 0.9890, the correct multiplier is: $R_f/R_0 = 1/0.9890 = 1.0111$.

Campbell Scientific Companies

Campbell Scientific, Inc. (CSI)

815 West 1800 North
Logan, Utah 84321
UNITED STATES
www.campbellsci.com
info@campbellsci.com

Campbell Scientific Africa Pty. Ltd. (CSAf)

PO Box 2450
Somerset West 7129
SOUTH AFRICA
www.csafrica.co.za
cleroux@csafrica.co.za

Campbell Scientific Australia Pty. Ltd. (CSA)

PO Box 444
Thuringowa Central
QLD 4812 AUSTRALIA
www.campbellsci.com.au
info@campbellsci.com.au

Campbell Scientific do Brazil Ltda. (CSB)

Rua Luisa Crapsi Orsi, 15 Butantã
CEP: 005543-000 São Paulo SP BRAZIL
www.campbellsci.com.br
suporte@campbellsci.com.br

Campbell Scientific Canada Corp. (CSC)

11564 - 149th Street NW
Edmonton, Alberta T5M 1W7
CANADA
www.campbellsci.ca
dataloggers@campbellsci.ca

Campbell Scientific Ltd. (CSL)

Campbell Park
80 Hathern Road
Shepshed, Loughborough LE12 9GX
UNITED KINGDOM
www.campbellsci.co.uk
sales@campbellsci.co.uk

Campbell Scientific Ltd. (France)

Miniparc du Verger - Bat. H
1, rue de Terre Neuve - Les Ulis
91967 COURTABOEUF CEDEX
FRANCE
www.campbellsci.fr
campbell.scientific@wanadoo.fr

Campbell Scientific Spain, S. L.

Psg. Font 14, local 8
08013 Barcelona
SPAIN
www.campbellsci.es
info@campbellsci.es