

INSTRUCTION MANUAL

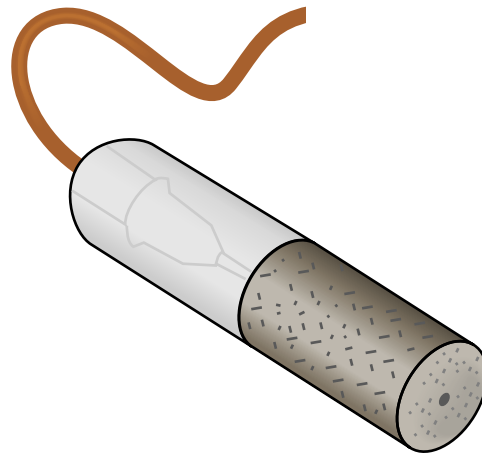

229 Heat Dissipation Matrix Water Potential Sensor

10/06



Copyright © 2006
Campbell Scientific, Inc.

WARRANTY AND ASSISTANCE

This equipment is warranted by CAMPBELL SCIENTIFIC (CANADA) CORP. ("CSC") to be free from defects in materials and workmanship under normal use and service for **twelve (12) months** from date of shipment unless specified otherwise. ***** **Batteries are not warranted.** ***** CSC's obligation under this warranty is limited to repairing or replacing (at CSC's option) defective products. The customer shall assume all costs of removing, reinstalling, and shipping defective products to CSC. CSC will return such products by surface carrier prepaid. This warranty shall not apply to any CSC products which have been subjected to modification, misuse, neglect, accidents of nature, or shipping damage. This warranty is in lieu of all other warranties, expressed or implied, including warranties of merchantability or fitness for a particular purpose. CSC is not liable for special, indirect, incidental, or consequential damages.

Products may not be returned without prior authorization. To obtain a Return Merchandise Authorization (RMA), contact CAMPBELL SCIENTIFIC (CANADA) CORP., at (780) 454-2505. An RMA number will be issued in order to facilitate Repair Personnel in identifying an instrument upon arrival. Please write this number clearly on the outside of the shipping container. Include description of symptoms and all pertinent details.

CAMPBELL SCIENTIFIC (CANADA) CORP. does not accept collect calls.

Non-warranty products returned for repair should be accompanied by a purchase order to cover repair costs.



CAMPBELL SCIENTIFIC
C A N A D A C O R P .

11564 - 149 street - edmonton - alberta - T5M 1W7
tel 780.454.2505 fax 780.454.2655

www.campbellsci.ca

229 Sensor Table of Contents

PDF viewers note: These page numbers refer to the printed version of this document. Use the Adobe Acrobat® bookmarks tab for links to specific sections.

1. General Description	1
1.1 Datalogger Compatibility	2
1.2 Measurement Principle	2
2. Specifications	3
3. Installation	4
3.1 Orientation.....	4
3.2 Contact.....	4
3.3 Equilibration and Saturation of the Sensor Before Installation	4
4. Wiring	4
5. Example Programs	5
5.1 Choosing a Reference for the Thermocouple Readings	5
5.2 Adjusting for Thermal Properties of Sensor During Early Heating Times	6
5.3 Datalogger Program Structure and Multiplexers	6
5.4 Temperature Correction.....	7
5.5 Example #1 — CR10X with 229 Sensor	8
5.6 Example #2 — CR10X with AM16/32, CE4, and Sixteen 229 Sensors	11
5.7 Example #3 — CR1000 with CE4 and Four 229s.....	14
5.8 Example #4 — CR1000 with AM16/32, CE4 and Sixteen 229 Sensors with Temperature Correction	16
6. Calibration	18
6.1 General.....	18
6.2 Normalized Temperature Change and Correction for Soil Temperature	19
6.2.1 Normalized Temperature Change	19
6.2.2 Correction for Soil Temperature	20
6.3 Using Pressurized Extraction Methods.....	23
6.4 General Description of Calibration/Measurement Process using Pressure Plate Extractor	23
6.4.1 Wiring for Calibration using Pressure Plate Extractor.....	24
7. Maintenance	25
8. Troubleshooting	26

9. References.....27

List of Tables

4-1. 229 Sensor and CE4/CE8 Wiring..... 5
5-1. 229 Sensor and CE4/CE8 Wiring with CR10XTCR..... 8
5-2. 229 Sensor and CE4/CE8 Wiring with AM16/32 Multiplexer..... 11
5-3. Wiring for Four 229s with CR1000 and CE4..... 14
5-4. 229 Sensor and CE4 Wiring with CR1000 and AM16/32 16

List of Figures

1-1. 229 Heat Dissipation Matric Water Potential Sensor and Hypodermic
Assembly 1
1-2. CE4 and CE8 Current Excitation Modules..... 2
1-3. Typical Temperature Response of 229 Sensor in Silt Loam Soil..... 3
4-1. Schematic of Connections for Measurement of a 229 Sensor 5
6-1. Data Points and Regression for Typical Calibration 19
6-2. Measurement error for range of soil temperatures and wide range of
matric potential..... 21
6-3. Measurement error for range of soil temperatures and wetter range of
matric potential..... 22
6-4. Datalogger and Peripheral Connections for 229 Calibration..... 25

229 Heat Dissipation Matric Water Potential Sensor

1. General Description

The 229 Heat Dissipation Matric Water Potential Sensor uses a heat dissipation method to indirectly measure soil water matric potential. The active part of the 229 Soil Water Potential Sensor is a cylindrically-shaped porous ceramic body. A heating element which has the same length as the ceramic body is positioned at the center of the cylinder. A thermocouple is located at mid-length of the ceramic and heating element. The position of the heating element and the thermocouple is maintained by placing both inside a hypodermic needle. This also protects the delicate wires. The volume inside the needle which is not occupied by wiring is filled with epoxy.

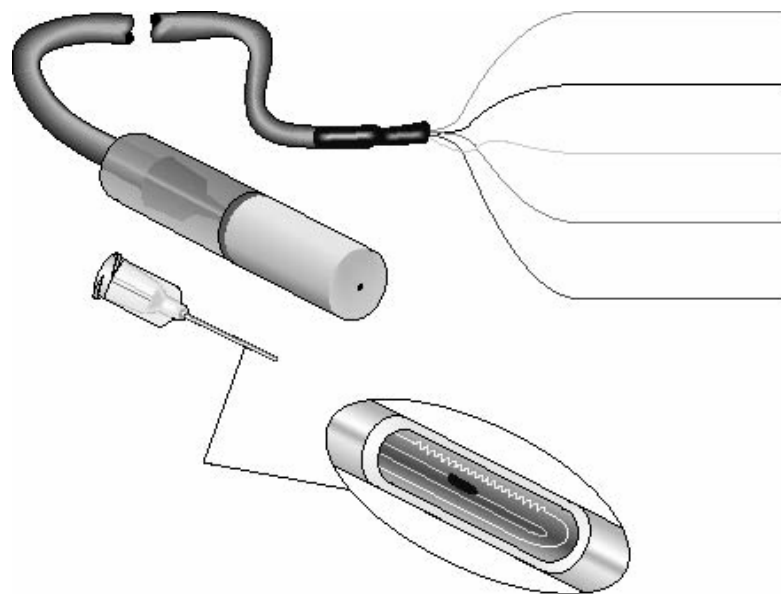

FIGURE 1-1. A 229 Heat Dissipation Matric Water Potential Sensor is shown at the top. The hypodermic assembly (without epoxy and ceramic) is shown just below. Cutaway view shows longitudinal section of the needle with heater and thermocouple junction.

The ceramic cylinder has a diameter of 1.5 cm and a length of 3.2 cm. Three copper wires and one constantan wire, contained in a shielded, burial-grade sheath provide a path for connection to measuring instrumentation. An epoxy section which is the same diameter as the ceramic matrix gives strain relief to the cable.

The 229 is used to measure soil water matric potential in the range -10 kPa to -2500 kPa. The method relies on hydraulic continuity between the soil and the sensor ceramic for water exchange. The variability in heat transfer properties among sensors makes individual calibration by the user a requirement. See Section 6 for calibration information.

Use of the 229 sensor requires a constant current source. Campbell Scientific offers the CE4 and CE8 current excitation modules (Figure 1-2), which have respectively four and eight regulated outputs of 50 milliamp ± 0.25 milliamp. All of the outputs of the excitation module are switched on or off simultaneously by setting a single datalogger control port to its high or low state.

The -L option on the model 229 Heat Dissipation Matric Water Potential Sensor (229-L) indicates that the cable length is user specified. This manual refers to the sensor as the 229.

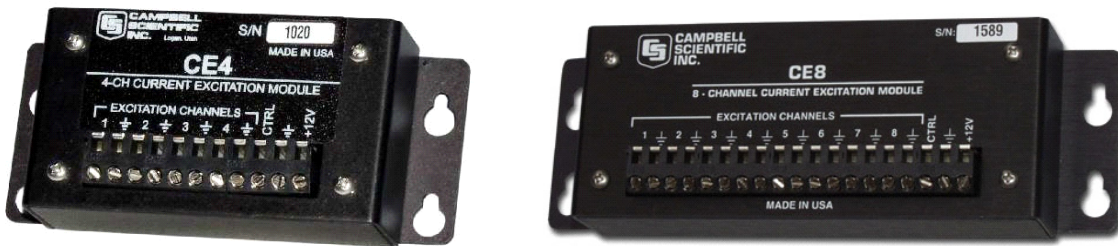

FIGURE 1-2. CE4 and CE8 Current Excitation Modules

1.1 Datalogger Compatibility

The 229 sensor is compatible with the 21X, CR7, CR10(X), CR23X, CR800, CR850, CR1000, and CR3000 dataloggers.

1.2 Measurement Principle

Movement of water between the 229 ceramic matrix and the surrounding soil occurs when a water potential gradient exists. When the water potential of the soil surrounding a 229 sensor changes, a water flux with the ceramic matrix will occur. The time required for hydraulic equilibration of the water in the soil and ceramic depends on both the magnitude of the water potential gradient and the hydraulic conductivity. Typically this equilibration time is on the order of minutes or tens of minutes.

A change in the water potential and water content of the ceramic matrix causes a corresponding change in the thermal conductivity of the ceramic/water complex. As the water content in the ceramic increases, the thermal conductivity of the complex also increases. At very low water contents, the ceramic material controls the thermal conductivity. As water content in the ceramic increases, water films are established between the solid particles, resulting in a rapid increase in thermal conductivity. As the pores in the ceramic continue to fill, the thermal conductivity becomes increasingly controlled by the continuous water and the increase in thermal conductivity of the ceramic/water complex approaches a constant value.

When a constant power is dissipated from the line heat source, the temperature increase near the heat source will depend on the thermal conductivity of the ceramic/water complex surrounding the heater. A temperature increase is caused by heat that is not dissipated. As the water content and thermal conductivity of the ceramic increases, the temperature increase as measured by the thermocouple will be reduced because conduction of the thermal energy

from the heat source is greater. A drier sensor will have a lower thermal conductivity, so the thermal energy will not dissipate as quickly and the temperature rise will be greater. When 50 milliamps is passed through the heating element for 30 seconds, the temperature increase ranges from approximately 0.7°C under wet conditions to 3.0°C when dry. Figure 1-3 presents a typical temperature response in a silt loam.

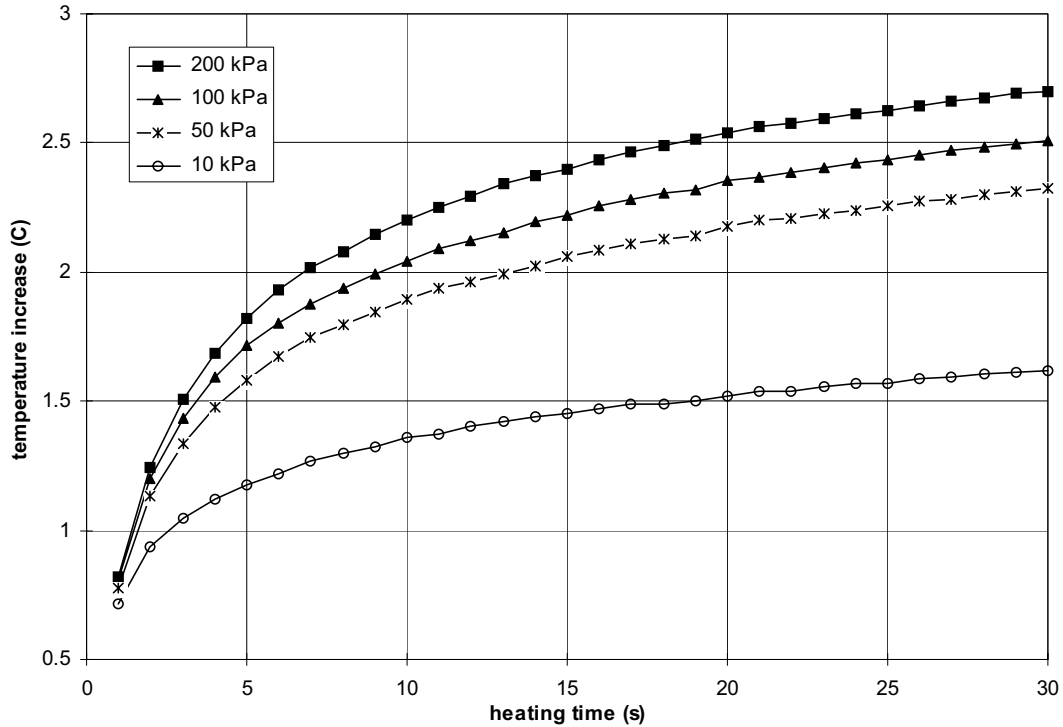

FIGURE 1-3. Typical Temperature Response of 229 Sensor in Silt Loam Soil

2. Specifications

229

Measurement range:	-10 to -2500 kPa
Measurement time:	30 seconds typical
Thermocouple type:	copper / constantan (type T)
Dimensions:	1.5 cm (0.6") diameter 3.2 cm (1.3") length of ceramic cylinder 6.0 cm (2.4") length of entire sensor
Weight:	10 g (0.35 oz) plus 23 g/m (0.25 oz/ft) of cable
Heater resistance:	34 ohms plus cable resistance
Resolution:	~1 kPa at matric potentials greater than -100 kPa

CE4/CE8

Output:	50 mA \pm 0.25 mA per channel, regulated
Output channels:	CE4: 4 CE8: 8
Current drain(while active):	25 mA + 50 mA * no. of 229's connected to the CE4 or CE8 output channels.
Dimensions:	CE4: 11.5 cm (4.5") x 5.4 cm (2.1") x 2.7 cm (1.1") CE8: 16.5 cm (6.5") x 5.4 cm (2.1") x 2.7 cm (1.1")
Weight:	CE4: 131 g (4.6 oz) CE8: 184 g (6.5 oz)

3. Installation

3.1 Orientation

For best measurement results, the 229 should be installed horizontally at the desired depth of the soil. This will reduce distortion of typical vertical water flux.

3.2 Contact

Good contact must exist between the ceramic matrix and the soil since the measurement relies on water flux between the two. Adequate contact will result if the sensor is 'planted' in a manner similar to that used for seedlings. Sufficient contact in coarse texture soils such as medium and coarse sand can be obtained by surrounding the ceramic portion with a slurry of fine silica (sometimes referred to as silica flour).

3.3 Equilibration and Saturation of the Sensor Before Installation

The smaller the difference in water potential between the 229 ceramic and the surrounding soil, the sooner equilibrium will be reached. Filling the ceramic pores with liquid water will optimize the hydraulic conductivity between the ceramic and soil.

Simple immersion of the sensors in water can leave some entrapped air in the pores. Complete saturation can be closely approached if (1) deaerated water is used, and (2) saturation occurs in a vacuum. Soaking the ceramic in free water for 12 hours followed by soaking under a vacuum of ≥ 71 kPa (0.7 atm) atmosphere for 1 hour results in complete saturation of the sensor.

4. Wiring

Table 4-1 shows wiring information for the 229 sensor and CE4 or CE8 excitation module when connecting sensors directly to the datalogger without the use of a multiplexer. Figure 4-1 shows a simple schematic of these connections.

See the multiplexer program in Section 5 for details on multiplexer wiring.

TABLE 4-1. 229 Sensor and CE4/CE8 Wiring			
229 Wire Color	Function	CR10(X), CR23X, CR800, CR850, CR1000, CR3000	CE4/CE8
Blue	Thermocouple High	High side of differential channel	
Red	Thermocouple Low	Low side of differential channel	
Green	Heater High		Current excitation channel
Black	Heater Low		⏏
Clear	Shield	G	
	CE4/CE8 Power	12V	+12V
	CE4/CE8 Ground	G	⏏
	CE4/CE8 Enable	Control Port	CTRL

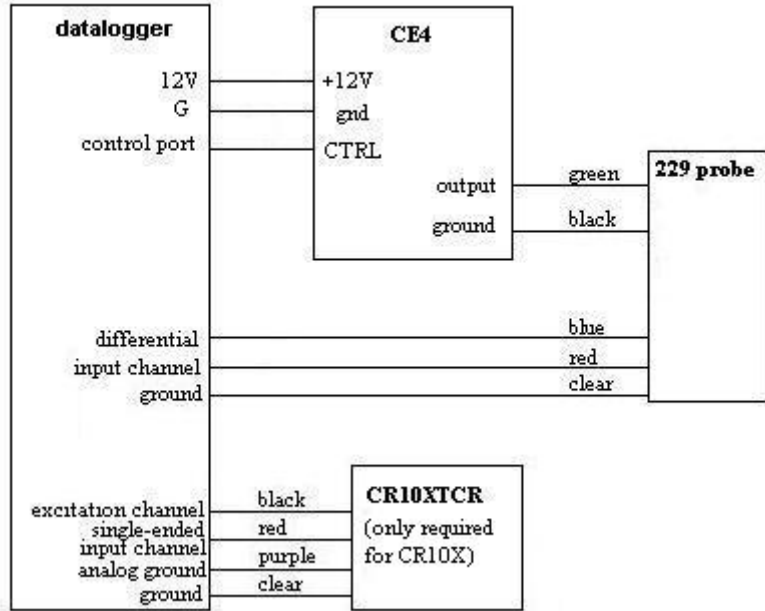

FIGURE 4-1. Schematic of Connections for Measurement of a 229 Sensor

5. Example Programs

5.1 Choosing a Reference for the Thermocouple Readings

A fundamental thermocouple circuit uses two thermocouple junctions with one pair of common-alloy leads tied together and the other pair connected to a voltage readout device. One of the junctions is the reference junction and is generally held at a known temperature. The temperature at the other junction can be determined by knowing the voltage potential difference between the junctions and the reference temperature.

A Campbell Scientific datalogger can read a single thermocouple junction directly because the temperature at the wiring panel is measured with a thermistor and this temperature is converted to a voltage which is then used as a thermocouple reference. A thermocouple circuit voltage potential is affected by the temperature of all dissimilar metal junctions. When using an AM16/32 multiplexer with the 229 sensor, the temperature of the AM16/32 can be used as the reference temperature if a thermistor probe such as the 107 is taped to the multiplexer panel near the 229 wires. Alternately, a CR10XTCR can be used to get an accurate reading of the CR10X wiring panel temperature and type T thermocouple wire (copper-constantan) can be used for the signal wires between the differential voltage channel on the datalogger and the appropriate common channels on the multiplexer (see program example #2 below). The CR23X, CR800, CR1000, and CR3000 can use their own internal panel temperature measurement instead of the CR10XTCR and type T thermocouple wire to the multiplexer common channels as previously noted. The use of insulation or an enclosure to keep the AM16/32 and temperature sensor at the same temperature will improve measurement quality.

5.2 Adjusting for Thermal Properties of Sensor During Early Heating Times

The discussion presented at the beginning of the calibration section (Section 6) describes how thermal properties can vary from sensor-to-sensor. The thermal properties of the needle casing, wiring, and the amount of contact area between the needle and the ceramic have a slight effect on the temperature response. Most of the nonideal behavior of the sensor is manifest in the first second of heating. The measurement is improved if the temperature after 1 s is subtracted from some final temperature. A typical ΔT would be $T(30\text{ s}) - T(1\text{ s})$.

5.3 Datalogger Program Structure and Multiplexers

The sequence of datalogger instructions for a 229 measurement is as follows:

- 1) Measure sensor temperature prior to heating.
- 2) Set a control port high to enable constant current excitation module and begin heating.
- 3) Wait for one second of heating and measure sensor temperature.
- 4) Wait for 29 more seconds of heating and measure sensor temperature.
- 5) Set control port low to disable the constant current excitation module and end heating.
- 6) Calculate temperature rise by subtracting $T(1\text{ s})$ from $T(30\text{ s})$.

Since all of the output channels of the CE4 or CE8 are activated when the control terminal is set high, power will be applied to all of the 229 sensors connected to the current source. Inaccurate measurements can result if the temperature of multiple sensors is simply read sequentially. The inaccuracy can occur because a finite amount of time is required to execute each of the temperature measurement instructions.

For example, a CR10X making multiple differential thermocouple readings with 60 Hz rejection takes 34.9 ms to read one thermocouple, and 30.9 ms more for each additional thermocouple. In a configuration where six 229 sensors are connected to a CE8 with their thermocouple wires connected sequentially to the CR10X wiring panel, the sixth 229 sensor will heat for 154.5 ms longer than the first sensor each time its temperature is measured. The amount of time between temperature measurement of the first sensor and the last sensor can be as long as 0.5 seconds under some measurement configurations.

The error caused by this difference in heating times can be minimized if the sensors are connected to the constant current excitation module and datalogger during calibration in exactly the same order they will be wired during field deployment. The difference in heating times can be eliminated altogether by heating the sensors one at a time through a multiplexer such as the AM16/32.

The AM 16/32 multiplexer in 4x16 mode provides a convenient method to measure up to sixteen 229 sensors. Since four lines are switched at once, both the thermocouple and the heating element leads for each sensor can be connected to a multiplexer channel. A measurement sequence is executed on each sensor. See program example #2 below for instructions on wiring and programming multiple 229 sensors on a multiplexer.

NOTE

When using multiplexers, the user should be aware that switching currents of greater than 30 mA will degrade the contact surfaces of the mechanical relays. This degradation will adversely affect the suitability of these relays to multiplex low voltage signals. Although a relay used in this manner no longer qualifies for low voltage measurements, it continues to be useful for switching currents in excess of 30 mA. Therefore, the user is advised to record which multiplexer channels are used to multiplex the 50 mA excitation for the 229-L sensors in order to avoid using those channels for low voltage measurements in future applications.

5.4 Temperature Correction

The rise in temperature over the 30 second heating time will be affected by the initial temperature of the 229 sensor. The measurement can be corrected for temperature if it can first be normalized. See Section 6.2.1 for more information on normalizing the sensor output.

Correct for temperature in the datalogger program following these steps outlined in Flint, et al. (2002):

1. Determine normalized dimensionless temperature rise, T_{norm} as described in Section 6.2.1 equation 3

$$T_{norm} = \frac{\Delta T_{dry} - \Delta T}{\Delta T_{dry} - \Delta T_{wet}}$$

- Determine where T_{norm} falls on the dimensionless slope function, s^*

$$s^* = -0.0133T_{norm}^5 + 0.0559T_{norm}^4 - 0.0747T_{norm}^3 + 0.0203T_{norm}^2 + 0.011T_{norm} + 0.0013$$

- Determine corrected dimensionless temperature rise, $T_{normcorr}$

$$T_{normcorr} = T_{norm} - s^*(T_{soil} - T_{cal})$$

- Determine corrected temperature rise, ΔT_{corr}

$$\Delta T_{corr} = \Delta T_d - T_{normcorr}(\Delta T_{dry} - \Delta T_{wet})$$

The corrected temperature rise can now be used to calculate soil water matrix potential. Example 4 below shows how to make the temperature correction with a CR1000.

5.5 Example #1 — CR10X with 229 Sensor

Table 5-1 shows wiring information for reading a single sensor with a CR10X datalogger, CE4 current excitation module, and CR10XTCR thermocouple reference temperature sensor.

229	Function	CR10(X)	CE4	CR10XTCR
Blue	229 Thermocouple High	1H		
Red	229 Thermocouple Low	1L		
Green	229 Heater High		Channel 1	
Black	229 Heater Low		$\underline{\underline{\text{G}}}$	
Clear	229 Shield	G		
	CE4/CE8 Power	12V	+12V	
	CE4/CE8 Ground	G	$\underline{\underline{\text{G}}}$	
	CE4/CE8 Enable	C1	CTRL	
	CR10XTCR Signal	2H		Red
	CR10XTCR Signal Return	AG		Clear
	CR10XTCR Excitation	E3		Black

```

;{CR10X}
;Program to read 1 229-L sensor
;Reading 1 sensor takes 30 seconds

*Table 1 Program
01: 60          Execution Interval (seconds)

1: If time is (P92)
  1: 0          Minutes (Seconds --) into a
  2: 60         Interval (same units as above)
  3: 11        Set Flag 1 High

2: If Flag/Port (P91)
  1: 11        Do if Flag 1 is High
  2: 30        Then Do

  3: Temp (107) (P11)                                ;Measure reference temperature
    1: 1        Reps
    2: 3        SE Channel
    3: 3        Excite all reps w/E3
    4: 1        Loc [ Ref_Temp ]
    5: 1.0      Multiplier
    6: 0.0      Offset

  4: Thermocouple Temp (DIFF) (P14)                  ;Measure initial sensor temperature
    1: 1        Reps
    2: 1        2.5 mV Slow Range
    3: 1        DIFF Channel
    4: 1        Type T (Copper-Constantan)
    5: 1        Ref Temp (Deg. C) Loc [ Ref_Temp ]
    6: 2        Loc [ Tinit_1 ]
    7: 1.0      Mult
    8: 0.0      Offset

  5: Do (P86)                                         ;Turn on CE8
    1: 41        Set Port 1 High

  6: Excitation with Delay (P22)                      ;Wait one second before taking first reading
    1: 1        Ex Channel
    2: 0000     Delay W/Ex (0.01 sec units)
    3: 100     Delay After Ex (0.01 sec units)
    4: 0        mV Excitation

  7: Thermocouple Temp (DIFF) (P14)                  ;Take 1 second temperature reading
    1: 1        Reps
    2: 1        2.5 mV Slow Range
    3: 4        DIFF Channel
    4: 1        Type T (Copper-Constantan)
    5: 1        Ref Temp (Deg. C) Loc [ ref_temp ]
    6: 3        Loc [ T1sec_1 ]
    7: 1.0      Mult
    8: 0.0      Offset

```

```

8: Excitation with Delay (P22)                ;Wait 29 more seconds for next reading
  1: 1      Ex Channel
  2: 0      Delay W/Ex (0.01 sec units)
  3: 2900   Delay After Ex (0.01 sec units)
  4: 0000   mV Excitation

9: Thermocouple Temp (DIFF) (P14)           ;Take 30 second temperature reading
  1: 1      Reps
  2: 1      2.5 mV Slow Range
  3: 4      DIFF Channel
  4: 1      Type T (Copper-Constantan)
  5: 1      Ref Temp (Deg. C) Loc [ ref_temp ]
  6: 4      Loc [ T30sec_1 ]
  7: 1.0    Mult
  8: 0.0    Offset

10: Do (P86)                                ;turn off CE8
  1: 52      Set Port 2 Low

11: Z=X-Y (P35)                             ;Calculate delta T
  1: 4      X Loc [ T30sec_1 ]
  2: 3      Y Loc [ T1sec_1 ]
  3: 5      Z Loc [ deltaT_1 ]

12: Do (P86)                                ;Save readings to final storage
  1: 10     Set Output Flag High (Flag 0)

13: Set Active Storage Area (P80)
  1: 1      Final Storage Area 1
  2: 229   Array ID

14: Real Time (P77)
  1: 1220   Year,Day,Hour/Minute (midnight = 2400)

15: Sample (P70)
  1: 1      Reps
  2: 2      Loc [ Tinit_1 ]

16: Sample (P70)
  1: 1      Reps
  2: 5      Loc [ deltaT_1 ]

17: Do (P86)                                ;Disable flag 1
  1: 21     Set Flag 1 Low

18: End (P95)

```

5.6 Example #2 — CR10X with AM16/32, CE4, and Sixteen 229 Sensors

Table 5-2 shows wiring information for connecting multiple 229 sensors and CE4 or CE8 excitation module to an AM16/32 multiplexer and CR10X datalogger. A CR10XTCR or 107 probe should be used for the reference temperature measurement as described at the beginning of this section. See Figure 6-4 for a schematic of this wiring configuration.

TABLE 5-2. 229 Sensor and CE4/CE8 Wiring with AM16/32 Multiplexer

229	107/CR10XTCR	Function	CR10(X)	CE4/CE8	AM16/32 (4x16 mode)
Blue		229 Thermocouple High			ODD H (1H, 3H, etc)
Red		229 Thermocouple Low			ODD L (1L, 3L, etc)
Green		229 Heater High			EVEN H (2H, 4H, etc)
Black		229 Heater Low			EVEN L (2L, 4L, etc)
Clear		229 Shield	G		$\underline{\underline{G}}$
		CE4/CE8 Power	12V	+12V	
		CE4/CE8 Ground	G	$\underline{\underline{G}}$	
		CE4/CE8 Enable	C1	CTRL	
			1H		COM ODD H*
			1L		COM ODD L*
		CE4/CE8 current excitation channel		Channel 1	COM EVEN H
		CE4/CE8 ground		$\underline{\underline{G}}$	COM EVEN L
		AM16/32 Power	12V		12V
		AM16/32 Ground	G		GND
		AM16/32 Enable	C2		RES
		AM16/32 Advance	C3		CLK
	Red	107 Signal	SE5		
	Black	107 Excitation	E1		
	Purple (Clear for CR10XTCR)	107 Signal Ground	AG		
	Clear (107 only)	107 Shield	G		

* Run copper wire from COM ODD H and COM ODD L to 1H/1L if using a 107 probe taped to the AM16/32 as the reference temperature sensor. If using a CR10XTCR as the reference temperature sensor, run copper wire from COM ODD H to 1H and run constantan wire from COM ODD L to 1L.

```

;{CR10X}
;Program to read 16 229-L sensors using 1 AM16/32 multiplexer
;and 1 CE4 or CE8 constant current interface
;Manually set Flag 1 high to force readings

*Table 1 Program
01: 30          Execution Interval (seconds)

1: Batt Voltage (P10)
  1: 1          Loc [ Batt_Volt ]

2: If time is (P92)                                ;Set Flag 1 high each hour
  1: 0          Minutes (Seconds --) into a
  2: 60         Interval (same units as above)
  3: 11         Set Flag 1 High

3: If Flag/Port (P91)
  1: 11         Do if Flag 1 is High
  2: 30         Then Do

4: Do (P86)                                         ;Turn on AM16/32
  1: 4          Set Port 2 High

5: Beginning of Loop (P87)                          ;Loop of 16 for 16 sensors on AM16/32
  1: 0          Delay
  2: 16         Loop Count

6: Do (P86)                                         ;Advance to next multiplexer channel
  1: 73         Pulse Port 3

7: Temp (107) (P11)                                 ;Measure reference temperature
  1: 1          Reps                               ;This is the same instruction
  2: 5          SE Channel                         ;for both the CR10X and 107
  3: 1          Excite all reps w/E1
  4: 2          Loc [ Tref_C ]
  5: 1.0        Mult
  6: 0.0        Offset

8: Thermocouple Temp (DIFF) (P14)                 ;Read initial temperature
  1: 1          Reps
  2: 21         10 mV, 60 Hz Reject, Slow Range
  3: 1          DIFF Channel
  4: 1          Type T (Copper-Constantan)
  5: 2          Ref Temp (Deg. C) Loc [ Tref_C ]
  6: 3          -- Loc [ Tinit_1 ]
  7: 1.0        Mult
  8: 0.0        Offset

9: Do (P86)                                         ;turn on CE8
  1: 41         Set Port 1 High

```

```

10: Excitation with Delay (P22)                ;Delay of 1 second
      1: 1          Ex Channel
      2: 0000       Delay W/Ex (0.01 sec units)
      3: 100        Delay After Ex (0.01 sec units)
      4: 0          mV Excitation

11: Thermocouple Temp (DIFF) (P14)           ;Read thermocouple after 1 second of heating
      1: 1          Repts
      2: 21         10 mV, 60 Hz Reject, Slow Range
      3: 1          DIFF Channel
      4: 1          Type T (Copper-Constantan)
      5: 2          Ref Temp (Deg. C) Loc [ Tref_C  ]
      6: 19        -- Loc [ T1s_1  ]
      7: 1.0        Mult
      8: 0.0        Offset

12: Excitation with Delay (P22)                ;delay 29 more seconds
      1: 1          Ex Channel
      2: 0          Delay W/Ex (0.01 sec units)
      3: 2900       Delay After Ex (0.01 sec units)
      4: 0000       mV Excitation

13: Thermocouple Temp (DIFF) (P14)           ;read temperature after 30 seconds heating
      1: 1          Repts
      2: 21         10 mV, 60 Hz Reject, Slow Range
      3: 1          DIFF Channel
      4: 1          Type T (Copper-Constantan)
      5: 2          Ref Temp (Deg. C) Loc [ Tref_C  ]
      6: 35        -- Loc [ T30s_1  ]
      7: 1.0        Mult
      8: 0.0        Offset

14: Do (P86)                                   ;turn off CE8
      1: 51         Set Port 1 Low

15: Z=X-Y (P35)                                ;Calculate temperature rise
      1: 35        -- X Loc [ T30s_1  ]
      2: 19        -- Y Loc [ T1s_1  ]
      3: 5         -- Z Loc [ dT_1  ]

16: End (P95)                                  ;end of loop

17: Do (P86)                                   ;Turn off AM16/32
      1: 52         Set Port 2 Low

18: End (P95)                                  ;End of then do statement

19: If Flag/Port (P91)
      1: 11         Do if Flag 1 is High
      2: 10         Set Output Flag High (Flag 0)

20: Set Active Storage Area (P80)
      1: 1          Final Storage Area 1
      2: 229        Array ID

```

21: Real Time (P77)		
1: 1220	Year,Day,Hour/Minute (midnight = 2400)	
22: Sample (P70)		<i>;Sample 16 initial soil temperature readings</i>
1: 16	Reps	
2: 3	Loc [Tinit_1]	
23: Sample (P70)		<i>;Sample 16 delta T readings</i>
1: 16	Reps	
2: 51	Loc [dT_1]	
24: Do (P86)		
1: 21	Set Flag 1 Low	

5.7 Example #3 — CR1000 with CE4 and Four 229s

Table 5-3 shows wiring information for reading four 229 sensors with a CR1000 datalogger and CE4 current excitation module.

TABLE 5-3. Wiring for Four 229s with CR1000 and CE4

229	CR1000	229	CE4
229 #1Blue	1H	229 #1 Green	Channel 1
229 #1Red	1L	229 #1 Black	⊥
229 #2Blue	2H	229 #2 Green	Channel 2
229 #2Red	2L	229 #2 Black	⊥
229 #3Blue	3H	229 #4 Green	Channel 3
229 #3Red	3L	229 #3 Black	⊥
229 #4Blue	4H	229 #4 Green	Channel 4
229 #4Red	4L	229 #4 Black	⊥
229 #1 Clear			⊥
229 #2 Clear			⊥
229 #3 Clear			⊥
229 #4 Clear			⊥
	12V		+12V
	G		⊥
	C1		CTRL

```

'CR1000
SequentialMode

Const Num229 = 4                               'Enter number of 229 sensors to measure
Dim LoopCount
Public RefTemp_C, StartTemp_C(Num229), Temp_1sec_C(Num229)
Public Temp_30sec_C(Num229), DeltaT_C(Num229)
Public Flag(1) as Boolean

Units StartTemp_C()=Deg C
Units DeltaT_C()=Deg C

DataTable(Matric,Flag(1),-1)
  Sample(Num229,StartTemp_C(),FP2)
  Sample(Num229,DeltaT_C(),FP2)
EndTable

BeginProg
Scan(30,Sec,1,0)
  PanelTemp (RefTemp_C,250)
  If IfTime (0,240,Min) Then Flag(1)=True 'Every 4 hours set Flag(1) high
  If Flag(1) = True Then                 'Flag(1) true triggers 229 readings
    'Measure starting temperature before heating
    TCDiff(StartTemp_C(),Num229,mV2_5C,1,TypeT,RefTemp_C,True,0,_60Hz,1,0)
    PortSet (1,1 )                       'Set C1 high to activate CE4
    Delay (0,1,Sec)                       'Wait 1 second
    'Measure temperature after 1 second of heating
    TCDiff(Temp_1sec_C(),Num229,mV2_5C,1,TypeT,RefTemp_C,True,0,_60Hz,1,0)
    'Measure temperature after 30 second of heating
    Delay (0,29,Sec)                      'Wait 29 seconds more for total of 30 seconds heating
    TCDiff(Temp_30sec_C(),Num229,mV2_5C,1,TypeT,RefTemp_C,True,0,_60Hz,1,0)
    PortSet (1,0 )                       'Set C1 low to deactivate CE4
    For LoopCount=1 to Num229
      'Calculate temperature rise
      DeltaT_C(LoopCount)=Temp_30sec_C(LoopCount)-Temp_1sec_C(LoopCount)
      'LoopCount=LoopCount+1
    Next LoopCount
  EndIf                                  'Ends Flag(1) true condition
  CallTable(Matric)                      'Call Data Tables and Store Data
  Flag(1)=False                          'Set Flag 1 false to disable 229 measurements
NextScan
EndProg

```

5.8 Example #4 — CR1000 with AM16/32, CE4 and Sixteen 229 Sensors with Temperature Correction

Table 5-4 shows wiring information for connecting multiple 229 sensors and CE4 excitation module to an AM16/32 multiplexer and CR1000 datalogger. See Figure 6-4 for a schematic of this wiring configuration.

TABLE 5-4. 229 Sensor and CE4 Wiring with CR1000 and AM16/32					
229	107	Function	CR1000	CE4	AM16/32 (4x16 mode)
Blue		229 Thermocouple High			ODD H (1H, 3H, etc)
Red		229 Thermocouple Low			ODD L (1L, 3L, etc)
Green		229 Heater High			EVEN H (2H, 4H, etc)
Black		229 Heater Low			EVEN L (2L, 4L, etc)
Clear		229 Shield	G		⊥
		CE4 Power	12V	+12V	
		CE4 Ground	G	⊥	
		CE4 Enable	C3	CTRL	
			1H		COM ODD H
			1L		COM ODD L
		CE4 current excitation channel		Channel 1	COM EVEN H
		CE4 Ground		⊥	COM EVEN L
		AM16 Power	12V		12V
		AM16/32 Ground	G		GND
		AM16/32 Enable	C1		RES
		AM16/32 Advance	C2		CLK
	Red	107 Signal	SE 3		
	Black	107 Excitation	EX1		
	Purple	107 Signal Ground	⊥		
	Clear	107 Shield	G		

```

'CR1000
SequentialMode
Const Num229 = 16                               'Enter number of 229 sensors to measure
Const read229 = 60                               'Enter Number of minutes between 229-L readings
Const CalTemp = 20                              'Enter calibration temperature (deg C)
Dim i, dTdry(Num229), dTwet(Num229)
Dim Tstar, Tstarcorr, DeltaTcorr, s
Public RefTemp_C, StartTemp_C(Num229), Temp_1sec_C(Num229)
Public Temp_30sec_C(Num229), DeltaT_C(Num229), dTcorr(Num229)
Public Flag(1) as Boolean

Units StartTemp_C()=Deg C
Units DeltaT_C()=Deg C
Units dTcorr() = Deg C

DataTable(Matric,Flag(1),-1)
  Sample(Num229,StartTemp_C(),FP2)
  Sample(Num229,DeltaT_C(),FP2)
  Sample(Num229,dTcorr(),FP2)
EndTable

Sub TempCorr                                     'Subroutine to temperature correct DeltaT_C
  Tstar=(dTdry(i)-DeltaT_C(i))/(dTdry(i)-dTwet(i))
  s=-0.0133*Tstar^5+0.0559*Tstar^4-0.0747*Tstar^3+0.0203*Tstar^2+0.011*Tstar+0.0013
  Tstarcorr=Tstar-s*(StartTemp_C(i)-CalTemp)
  DeltaTcorr=dTdry(i)-Tstarcorr*(dTdry(i)-dTwet(i))
EndSub

BeginProg
'Enter dTdry and dTwet values obtained for each probe (these are examples):
dTdry(1)= 3.421: dTdry(2)=3.417: dTdry(3)=3.433: dTdry(4)=3.418
dTdry(5)= 3.412: dTdry(6)=3.407: dTdry(7)=3.422: dTdry(8)=3.428
dTdry(9)= 3.399: dTdry(10)=3.377: dTdry(11)=3.405: dTdry(12)=3.406
dTdry(13)=3.422: dTdry(14)=3.431: dTdry(15)=3.423: dTdry(16)=3.408
dTwet(1)= 0.752: dTwet(2)=0.695: dTwet(3)=0.731: dTwet(4)=0.724
dTwet(5)= 0.709: dTwet(6)=0.752: dTwet(7)=0.739: dTwet(8)=0.737
dTwet(9)= 0.723: dTwet(10)=0.754: dTwet(11)=0.691: dTwet(12)=0.760
dTwet(13)=0.722: dTwet(14)=0.745: dTwet(15)=0.739: dTwet(16)=0.748
Scan(30,Sec,1,0)
  Therm107(RefTemp_C,1,3,1,0, 60Hz,1.0,0.0)      'Reference temperature measurement
  If IfTime (0,read229,Min) Then Flag(1)=True    'Set Flag(1) high based on time
  If Flag(1) = True Then                          'Flag(1) triggers 229 readings
    PortSet(1,1)                                  'Set C1 High to turn on multiplexer
    For i=1 to Num229
      PulsePort(2,10000)                          'Switch to next multiplexer channel

      'Measure starting temperature before heating
      TCDiff(StartTemp_C(i),1,mV2_5C,1,TypeT,RefTemp_C,True,0,_60Hz,1,0)
      PortSet (3,1 )                               'Set C3 high to activate CE4
      Delay (0,1,Sec)                              'Wait 1 second

      'Measure temperature after 1 second of heating
      TCDiff(Temp_1sec_C(i),1,mV2_5C,1,TypeT,RefTemp_C,True,0,_60Hz,1,0)
      Delay (0,29,Sec)                             'Wait 29 seconds more
    
```

```

'Measure temperature after 30 second of heating
TCDiff(Temp_30sec_C(i),1,mV2_5C,1,TypeT,RefTemp_C,True,0,_60Hz,1,0)

PortSet(3,0)                               'Set C3 low to deactivate CE4
DeltaT_C(i)=Temp_30sec_C(i)-Temp_1sec_C(i)'Calculate temperature rise
Call TempCorr                               'Call temperature correction subroutine
dTcorr(i)=DeltaTcorr
Next i
EndIf                                       'Ends Flag(1) high condition
PortSet(1,0)                               'Turn multiplexer Off
CallTable(Matric)                          'Call Data Tables and Store Data
Flag(1)=False                              'Disable 229 measurements
NextScan
EndProg

```

6. Calibration

6.1 General

The heat transfer properties of a 229 sensor depend both on the thermal properties of the various sensor materials and on the interfaces between the different materials. Heat transfer between the stainless steel needle containing the heating element and thermocouple and the ceramic material depends on the density of points-of-contact between two different materials. Heat transfer also depends on the arrangement of the wires in the hypodermic needle and the amount of contact between the needle and the ceramic. The uncontrollable variability in heat transfer properties warrants individual calibration of the 229 sensors.

The calibration used to relate temperature increase and the soil water potential is strictly empirical, and the functional expression of the relationship can take several forms. The most commonly used function is:

$$\psi = \exp(\alpha * \Delta T + \beta) \quad [1]$$

with ψ the soil water potential, \exp the exponential function, ΔT the temperature increase during the chosen heating period of time, α the slope and β the intercept.

The relationship between the natural logarithm of soil water tension and the temperature increase is linear which simplifies derivation of the calibration function.

$$\ln(|\psi|) = \alpha * \Delta T + \beta \quad [2]$$

(Soil water potential is a negative value and becomes more negative as soil dries.) Figure 6-1 is a typical calibration and the data set is easily described with linear regression. A power function works well in applications when calibration is needed for $-500 \text{ kPa} \leq \text{matric potential} \leq -10 \text{ kPa}$. A power function calibration has the form $|\psi| = a * (\Delta T)^b$ with the multiplier, a , and exponent, b , as fitted parameters.

A variety of calibration methods are suitable. The sole requirement is that the water potential of the medium surrounding the sensor must be known. Either the applied potential can be controlled at a specified value or the water potential can be independently measured. Hanging water columns and pressure plate extractors are typically used. Several data values which correspond to the water potential expected during sensor use should be included in the calibration

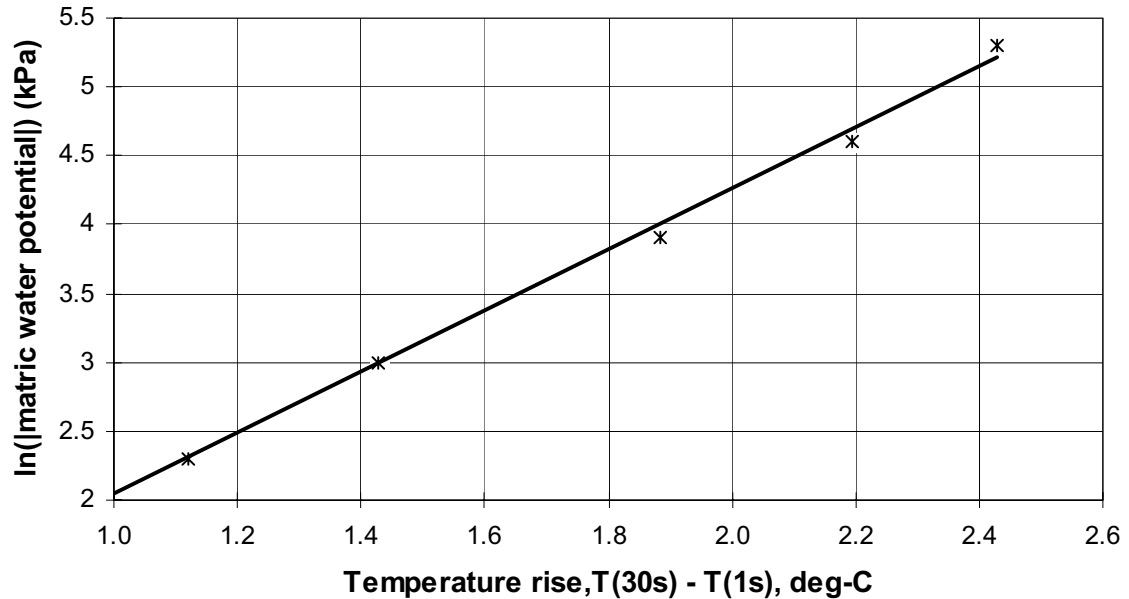

FIGURE 6-1. Data Points (x) and Regression for Typical Calibration

6.2 Normalized Temperature Change and Correction for Soil Temperature

6.2.1 Normalized Temperature Change

The effect of sensor-to-sensor variability can be reduced by using normalized temperature increase, ΔT_{norm} , described by

$$\Delta T_{norm} = \frac{\Delta T_{dry} - \Delta T}{\Delta T_{dry} - \Delta T_{wet}} \quad [3]$$

where ΔT_{dry} is the change in temperature during measurement when the 229 sensor is dry, ΔT_{wet} is the change in temperature during measurement when the 229 sensor is fully saturated and ΔT is the change in temperature during the measurement. The range of ΔT_{norm} will be 0 to 1 with ΔT_{norm} equal 0 for dry soil and 1 for saturated soil.

The ΔT_{wet} value requires full saturation of the ceramic. The ceramic portion of the sensor must be immersed in water while under vacuum to remove all air from the ceramic. Measurements at the factory show that complete saturation will occur after 3-4 hours at 0.7 atmospheres (70 kPa) vacuum. However, the arrangement of the sensors in the water during vacuum extraction may hamper movement of air from the ceramic. When tapping or jarring the container shows no release of bubbles, the ceramic is saturated.

The ΔT_{dry} value requires that the ceramic be as dry as possible. Sensors can be dried with desiccant or in an oven at temperature no greater than 60 °C. Temperatures greater than 60 °C may damage the sensor cable.

Reece (1996) suggested that inverse thermal conductivity can also be used as a normalization technique but work by Campbell Scientific has not shown significant advantage for this method over normalization as described by equation [3].

A calibration equation using ΔT_{norm} and having a form similar to equation [2] is

$$\ln(|\psi|) = \alpha * \Delta T_{norm} + \beta . \quad [4]$$

The slope of equation [2] will be positive while the slope of equation [4] will be negative.

6.2.2 Correction for Soil Temperature

The heat dissipation method of matric potential measurement is sensitive to temperature and correction for the temperature dependence may be necessary to maintain accuracy of the measurement. If the soil temperature when the matric potential measurements are made is close to the temperature at the time of sensor calibration there is no need for correction.

The 229 measurement method uses heat transfer away from a heated line source and the heat transfer depends on the thermal conductivity of the ceramic. The thermal conductivity of the ceramic depends on the combination of the conductivities of water, vapor and solid constituents. The vapor component has a strong temperature dependence and consequently imparts sensitivity of the measurement to temperature. The sensitivity is related to the difference between the temperature of the sensor at time of measurement (soil temperature) and the temperature of the sensor during calibration. Figures 6-2 and 6-3 show the response of the matric potential measurement for a range of temperatures when the calibration temperature is 20 C.

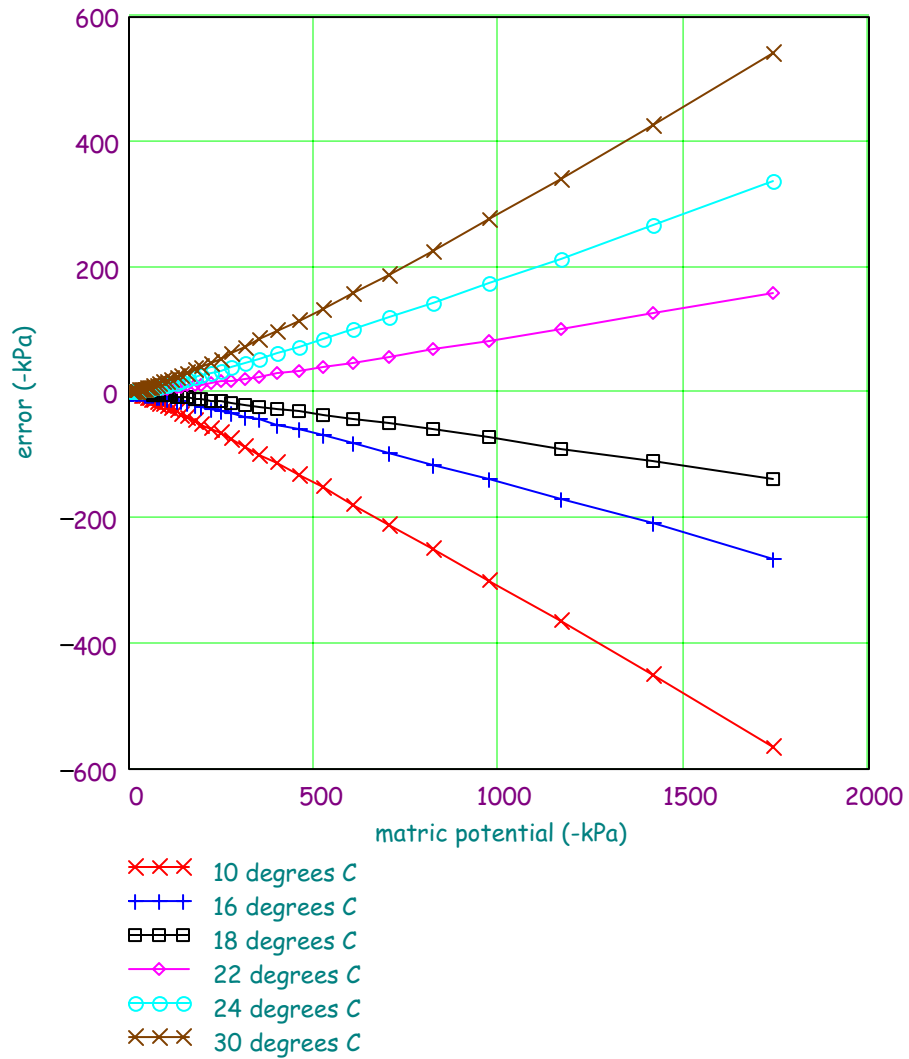

FIGURE 6-2. Measurement error for range of soil temperatures and wide range of matric potential.

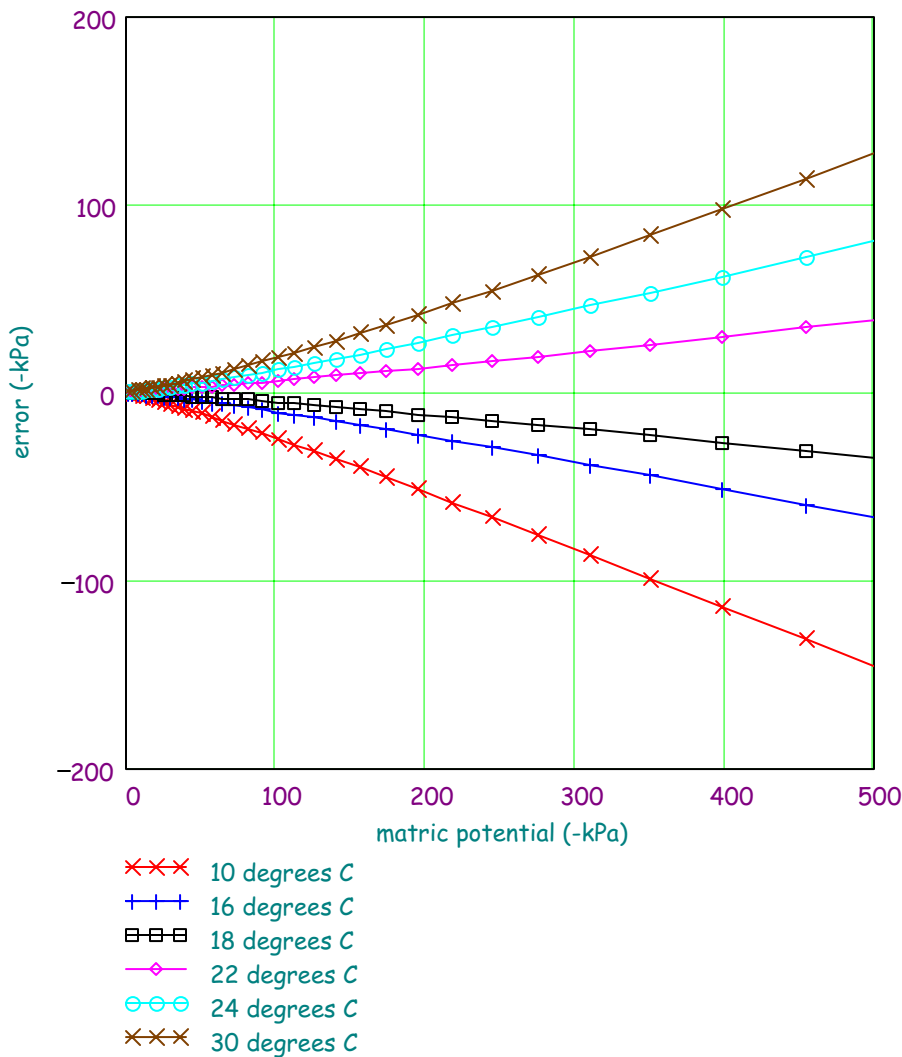

FIGURE 6-3. Measurement error for range of soil temperatures and wetter range of matric potential.

A temperature correction for the difference in temperature at time of calibration and time of measurement is provided in the work of Flint et al., 2002. To implement the correction, normalized temperature must be used for the calibration variable. Normalized temperature is as defined in equation [3].

The correction procedure is an iterative method. Examples of implementing the iterative routine with dataloggers are given in programming examples 5 and 6. The general sequence for using the temperature correction method is:

1. Determine ΔT_{dry} and ΔT_{wet} prior to calibration and with sensor conditions as described in 6.2.1. The recommended ΔT is the sensor temperature after 30 seconds of heating minus the sensor temperature after 1 second of heating.

2. With the sensor in place, use the ΔT from the in situ measurement along with the ΔT_{dry} , ΔT_{wet} values for the particular sensor to calculate ΔT_{norm} .
3. Implement the iterative temperature correction as presented in datalogger example program #4 to obtain a corrected ΔT_{norm} .
4. Use the corrected ΔT_{norm} in the calibration equation, e.g. equation [4].

6.3 Using Pressurized Extraction Methods

Pressurized extraction methods use a porous material (typically ceramic or stainless steel) to separate the pressurized soil sample from atmospheric pressure. One side of the porous material is in contact with the soil sample and the other side is at atmospheric pressure. A simple configuration is a cylinder which has the porous material as a bottom and a solid cap at the top which provides a pressure-tight seal after the soil sample has been placed on the porous bottom. This allows pressurization of the soil sample which will force water from the soil. The air entry pressure of the porous material is dependent on the effective pore diameter and must be greater than the maximum pressure applied during calibration. When a specified pressure is applied, all soil water at water potentials greater than $-1 \times (\text{applied pressure})$ will move through the soil sample and through the porous bottom. The time required for the soil water to leave the sample system depends on the pressure gradient and the hydraulic conductivity of the soil and the porous bottom plate.

Equilibration of water potential throughout the system must be attained or the accuracy of the water potential measurement using the derived calibration will be reduced. The simplest way to confirm equilibration is to repeat the measurements at a given applied pressure until readings do not change.

6.4 General Description of Calibration/Measurement Process using Pressure Plate Extractor

A pressure plate extractor consists of a high-pressure vessel, a porous plate and tubing to remove soil water from the soil sample. A ring with diameter slightly less than the diameter of the ceramic plate can be used to hold the soil in which the 229 sensors are buried. Smaller rings can also be used. The porous plate, soil and 229 sensors must be thoroughly saturated at the beginning of the calibration routine. Complete saturation of the ceramic plate and 229 sensors is better achieved by applying vacuum. The number of sensors that can be calibrated in a single pressure vessel will depend on the 229 cable lengths because of the limited space in the vessel.

The general calibration sequence is:

1. The extractor plate, soil and sensors are saturated and positioned in the pressure vessel.
2. The lowest calibration pressure chosen by the user (>10 kPa) is applied and the soil solution, which is held by the soil at an energy level less than that applied, is allowed to leave the pressurized system.

3. Measurements of sensor temperature response are made periodically to determine if equilibration is attained. This will require depressurization of the pressure vessel if a pressure-tight feedthrough is not used. Prior to depressurization, it is important that the effluent hose be blocked by clamping or other method to prevent solution from re-entering the soil and sensors.
4. When equilibration is attained, the effluent hose is blocked, the vessel is depressurized and 229 measurements are recorded.
5. The next calibration pressure is then applied and the process repeated.

Pressure-tight bulkhead connectors are available for some pressure vessels. Determining whether equilibrium has been reached is simplified when using a feedthrough connector since the pressure vessel doesn't have to be depressurized and opened for each reading. A temporary connector can be used to disconnect the datalogger from the other components installed in the pressure vessel.

Pressurized readings can be used for determining equilibrium but should not be used for calibration data. Thermal properties are affected by pressure and calibration data should be collected at the same pressure the sensors will be used—in most cases this is atmospheric pressure.

6.4.1 Wiring for Calibration using Pressure Plate Extractor

The wiring arrangement of Figure 6-4 depicts a datalogger with an AM16/32 multiplexer, a CE4 current source and a thermistor being used in a typical 229 calibration arrangement. This is similar to the wiring for program example #2 and #4 (see Section 5). All components except the datalogger can be placed inside a 5 bar pressure vessel. If this method is used, the electronic components in the pressure vessel should be protected against moisture damage. Place the components in a container such as plastic bag with desiccant.

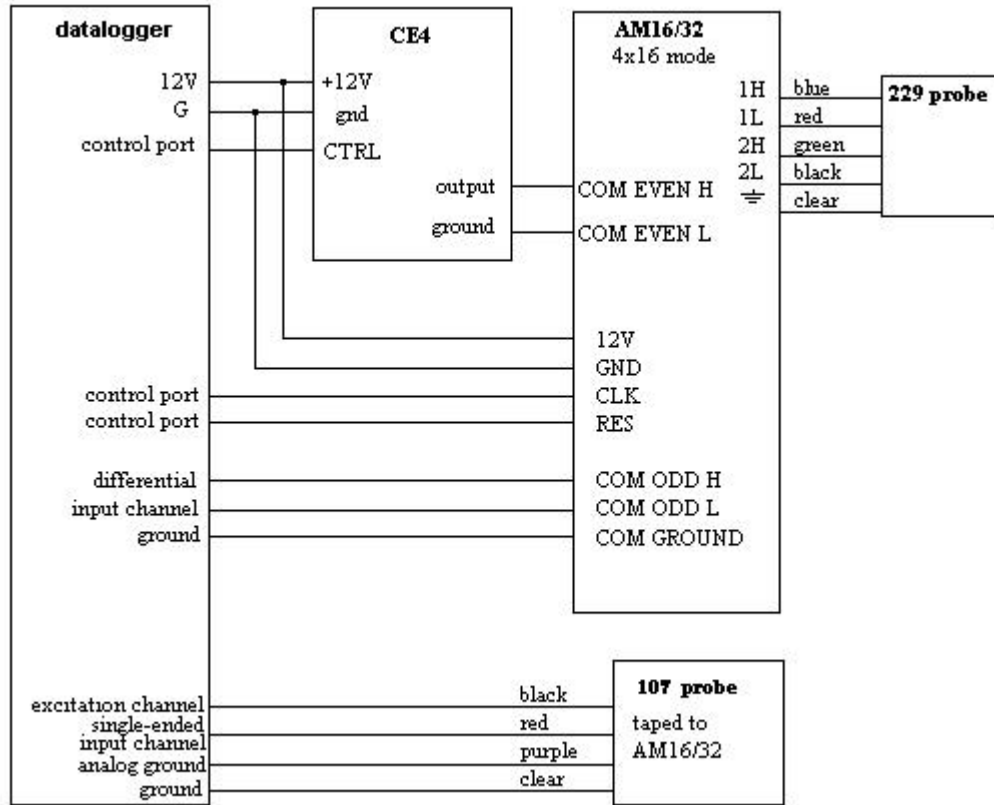

FIGURE 6-4. Datalogger and Peripheral Connections for 229 Calibration

7. Maintenance

The 229 does not require maintenance after it is installed in the soil. The datalogger, current excitation module, and multiplexer, if used, should be kept in a weatherproof enclosure. Periodic replacement of the desiccant in the enclosure is required to keep the electronics dry and free of corrosion.

8. Troubleshooting

Symptom	Possible Cause	Action
Temperature reading is offscale (-6999 or NAN)	Thermocouple wire not connected to correct datalogger channel	Check program to see which differential input channel 229 should be connected to and verify that it has a good connection to that channel
	Break in thermocouple wire	Use ohm-meter to measure resistance between blue and red wires. The reading in ohms should be approximately the cable length in feet. An open circuit indicates a break in the wire
	Multiplexer not operating properly	<p>Make sure that multiplexer has 12V between 12V and GND terminals.</p> <p>Check for a good electrical connection on the wires that connect RES and CLK to datalogger control ports.</p> <p>Check for a good electrical connection on the wires going from the common channels to the datalogger and the current excitation module.</p> <p>Check program to make sure that the control port connected to RES is being set high and the control port connected to CLK is being pulsed.</p>
DeltaT reading close to zero	Heater wire broken or not properly connected	Check resistance between terminal screws for green and black wires. It should read 34 - 40 ohms.
	Current excitation module not turning on	<p>Check for 12V between +12V and ground terminals</p> <p>Check for good electrical connection on wire connecting CTRL with datalogger control port</p> <p>Check program to make sure that control port connected to CTRL is being set high</p>
Temperature decreases during heating	Thermocouple wires reversed	Make sure blue wire is on the high side of the differential input channel and red is on the low side
Readings for first sensor on multiplexer are all right, but all others read zero	All readings are being written to the same input location (Edlog dataloggers)	Check program to make sure measurement instructions in the multiplexer loop are indexed (-- next to the input location number. Press F4 or C to toggle the --)

9. References

- Flint, A. L., G. S. Campbell, K. M. Ellett, and C. Calissendorff. 2002. Calibration and Temperature Correction of Heat Dissipation Matric Potential Sensors. *Soil Sci. Soc. Am. J.* 66:1439–1445.
- Reece, C.F. 1996. Evaluation of a line heat dissipation sensor for measuring soil matric potential. *Soil Sci. Soc. Am. J.* 60:1022–1028.

Campbell Scientific Companies

Campbell Scientific, Inc. (CSI)

815 West 1800 North
Logan, Utah 84321
UNITED STATES
www.campbellsci.com
info@campbellsci.com

Campbell Scientific Africa Pty. Ltd. (CSAf)

PO Box 2450
Somerset West 7129
SOUTH AFRICA
www.csafrica.co.za
cleroux@csafrica.co.za

Campbell Scientific Australia Pty. Ltd. (CSA)

PO Box 444
Thuringowa Central
QLD 4812 AUSTRALIA
www.campbellsci.com.au
info@campbellsci.com.au

Campbell Scientific do Brazil Ltda. (CSB)

Rua Luisa Crapsi Orsi, 15 Butantã
CEP: 005543-000 São Paulo SP BRAZIL
www.campbellsci.com.br
suporte@campbellsci.com.br

Campbell Scientific Canada Corp. (CSC)

11564 - 149th Street NW
Edmonton, Alberta T5M 1W7
CANADA
www.campbellsci.ca
dataloggers@campbellsci.ca

Campbell Scientific Ltd. (CSL)

Campbell Park
80 Hathern Road
Shepshed, Loughborough LE12 9GX
UNITED KINGDOM
www.campbellsci.co.uk
sales@campbellsci.co.uk

Campbell Scientific Ltd. (France)

Miniparc du Verger - Bat. H
1, rue de Terre Neuve - Les Ulis
91967 COURTABOEUF CEDEX
FRANCE
www.campbellsci.fr
campbell.scientific@wanadoo.fr

Campbell Scientific Spain, S. L.

Psg. Font 14, local 8
08013 Barcelona
SPAIN
www.campbellsci.es
info@campbellsci.es