

INSTRUCTION MANUAL



0872F1 Ice Detector

February 2011



Copyright © 2010
Campbell Scientific (Canada) Corp.

WARRANTY AND ASSISTANCE

This equipment is warranted by CAMPBELL SCIENTIFIC (CANADA) CORP. ("CSC") to be free from defects in materials and workmanship under normal use and service for **twelve (12) months** from date of shipment unless specified otherwise. ***** **Batteries are not warranted.** ***** CSC's obligation under this warranty is limited to repairing or replacing (at CSC's option) defective products. The customer shall assume all costs of removing, reinstalling, and shipping defective products to CSC. CSC will return such products by surface carrier prepaid. This warranty shall not apply to any CSC products which have been subjected to modification, misuse, neglect, accidents of nature, or shipping damage. This warranty is in lieu of all other warranties, expressed or implied, including warranties of merchantability or fitness for a particular purpose. CSC is not liable for special, indirect, incidental, or consequential damages.

Products may not be returned without prior authorization. To obtain a Return Merchandise Authorization (RMA), contact CAMPBELL SCIENTIFIC (CANADA) CORP., at (780) 454-2505. An RMA number will be issued in order to facilitate Repair Personnel in identifying an instrument upon arrival. Please write this number clearly on the outside of the shipping container. Include description of symptoms and all pertinent details.

CAMPBELL SCIENTIFIC (CANADA) CORP. does not accept collect calls.

Non-warranty products returned for repair should be accompanied by a purchase order to cover repair costs.



CAMPBELL SCIENTIFIC
C A N A D A C O R P .

11564 - 149 street - edmonton - alberta - T5M 1W7
tel 780.454.2505 fax 780.454.2655

www.campbellsci.ca

TABLE OF CONTENTS

1	INTRODUCTION	2
2	SPECIFICATION	4
3	INSTALLATION	5
3.1	Location	5
3.2	Mounting.....	5
3.3	Wiring	6
4	OPERATIONAL CHECK USING DATALOGGER	6
5	PROGRAMMING EXAMPLE FOR CR1000	8

APPENDICES

1	APPENDIX A.....	10
1.1	SAFETY SUMMARY.....	10
1.2	Operation	12
1.3	System Operation.....	12
1.4	Data Link	12
1.5	System Commands	13
1.6	Failure Detection	14
1.7	Probe Frequency Variation	15
1.8	Electrical Design.....	15
1.9	Maintenance.....	17
2	APPENDIX B	31
2.1	EC Declaration Certificate.....	31

TABLE OF FIGURES

Figure 1	Model 0872F1 Ice Detector.....	3
Figure 2	Mounting.....	5
Figure 3	Electrical Block Diagram.....	16
Figure 4	Assembly Drawing.....	26
Figure 5	Detail Assembly Drawing.....	27
Figure 6	CE Declaration of Conformity.....	31

1 INTRODUCTION

This technical manual provides operation and field level maintenance information for the 0872F1 Ice Detector manufactured by Goodrich Sensor Systems. The 0872F1 consists of four functional assemblies: a Main circuit card assembly (CCA), an Output Interface CCA, a Filter assembly, and a Strut and Probe assembly. The CCAs and all electrical connections are contained within the 0872F1s housing. Access to these items is made through a large, hinged cover that is secured to the housing with captive screws.

The 0872F1 detects ice accumulation on an ultrasonic axially vibrating tube and communicates the associated frequency changes through an RS-232 or digital current loop data link. The 0872F1 is mounted on a pole (Figure 1) and is designed to operate continuously in an outdoor environment. The 0872F1 requires only periodic recalibration; no other maintenance is normally required.

LIST OF ACRONYMS

CCA	Circuit Card Assembly
Bit	Built-In Test
EPROM	Electrically Programmable Read Only Memory
ESD	Electrostatic Discharge
FRU	Field Replacement Unit
IDS	Ice Detection Sensor

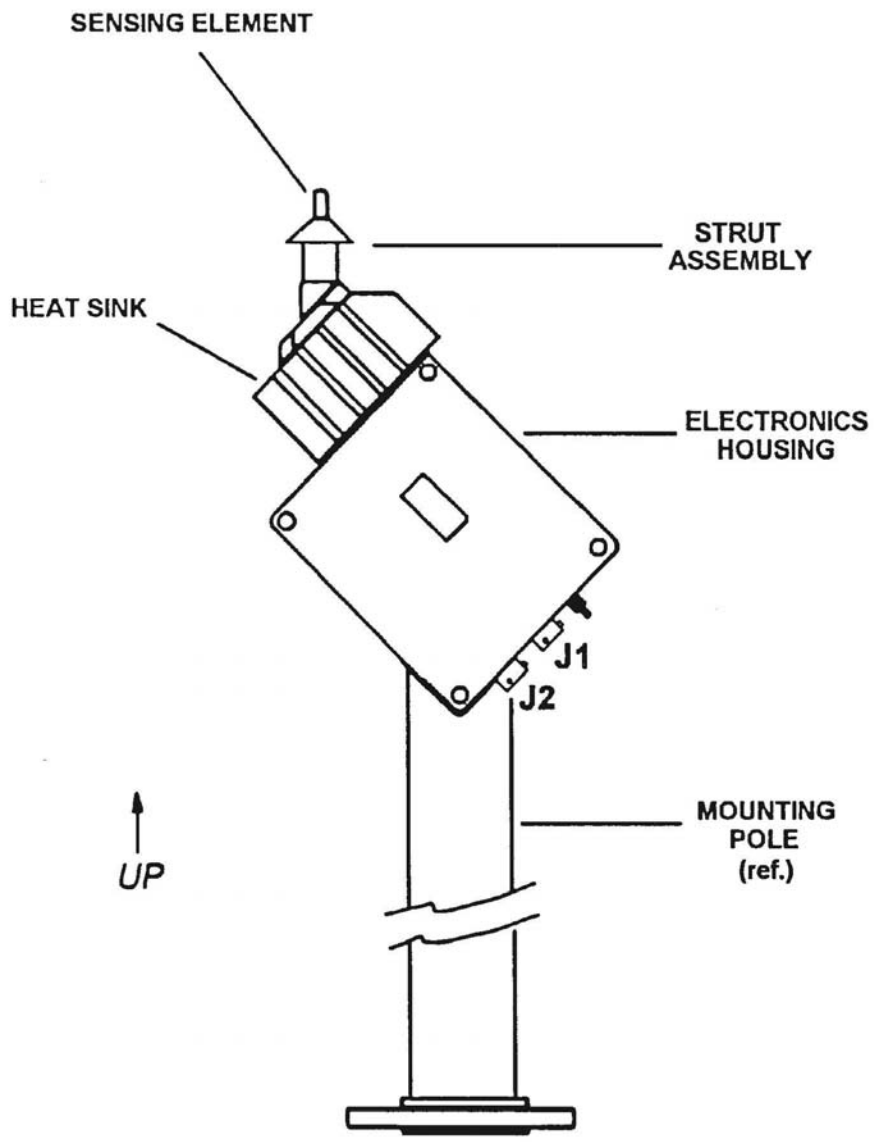

Figure 1. Model 0872F1 Ice Detector

2 SPECIFICATION

Power Requirements: 115 VAC, $\pm 10\%$, 60Hz

Power Consumption:

Sensing Mode: 10 Watts (0.087 Amps)

De-icing Mode: 385 Watts (3.35 Amps)

Output Format: RS-232, or RS232 Current Loop (2400 BAUD)

RS232 Configuration: 8 Data Bits, 1 Stop Bit, No Parity, Full Duplex, Configured as Data Terminal Equipment (DTE)

Output Commands: (see appropriate Section for more information)

Send Data: Z1

De-ice: Z3XX, where XX is time in seconds (maximum = 60 sec)

Extended Diagnostics: Z4

Field Calibration: F5

Measurement Range: 0 – 2.5 mm (0 – 0.10 inches) of Ice

Minimum Measurement Threshold: 0.13 mm (0.005 inches) of Ice

Resolution: ± 4 Hz

Environmental Limitations:

Operating Temperature: -50°C to $+50^{\circ}\text{C}$

Operating Humidity Limits: 74% RH @ 35°C to 100% RH @ 25°C

Wind: Steady - up to 55.5km (30 knots), Gust - up to 85.2km (46 knots)

Rain: 76.2mm (3") per hr with 55.5km (30 knots) winds

Freezing Rain: Ice accretion to 25.4mm (1") with a 37km (20 knot) wind, at a rate of 12.7mm (1/2") per hour

Ingress Protection: IPX4

Maximum Cable Length: 30 meters

Mating Connectors:

Connector 1 (J1): PT06J-12-13S

Connector 2 (J2): PT06J-12-10S

Cable Type:

0872E3CBL1-L (J1): 3 conductor, 16 AWG, Super Vu-Tron III jacket

0872E3CBL2-L (J2): Multiconductor, 2- pair, 22 AWG, Shielded, Santoprene jacket

Weight: 5.7 Kg (12.55 lbs)

Dimensions:

Electrical Housing: 230mm by 200mm by 110mm (L x W x D)

Sensing Element & Heat Sink: 164mm by 173mm by 110mm (Overall L x W x D)

Compliant Standards: CE and TUV (C / US)

3 INSTALLATION

3.1 Location

The 0872F1 should be mounted to a sturdy pole located away from buildings or other obstacles that could shadow the sensing element from freezing rain. The 0872F1 should be installed so that the sensing probe is a minimum 36 inches above the ground. The 0872E3 MNT mounting bracket (shown in Figure 2 below) is ideal for mounting the 0872F1 to the pole.

3.2 Mounting

1. Position the 0872F1 on mounting pole with the sensing probe pointing upward. Tighten band clamps (shown in photo below)

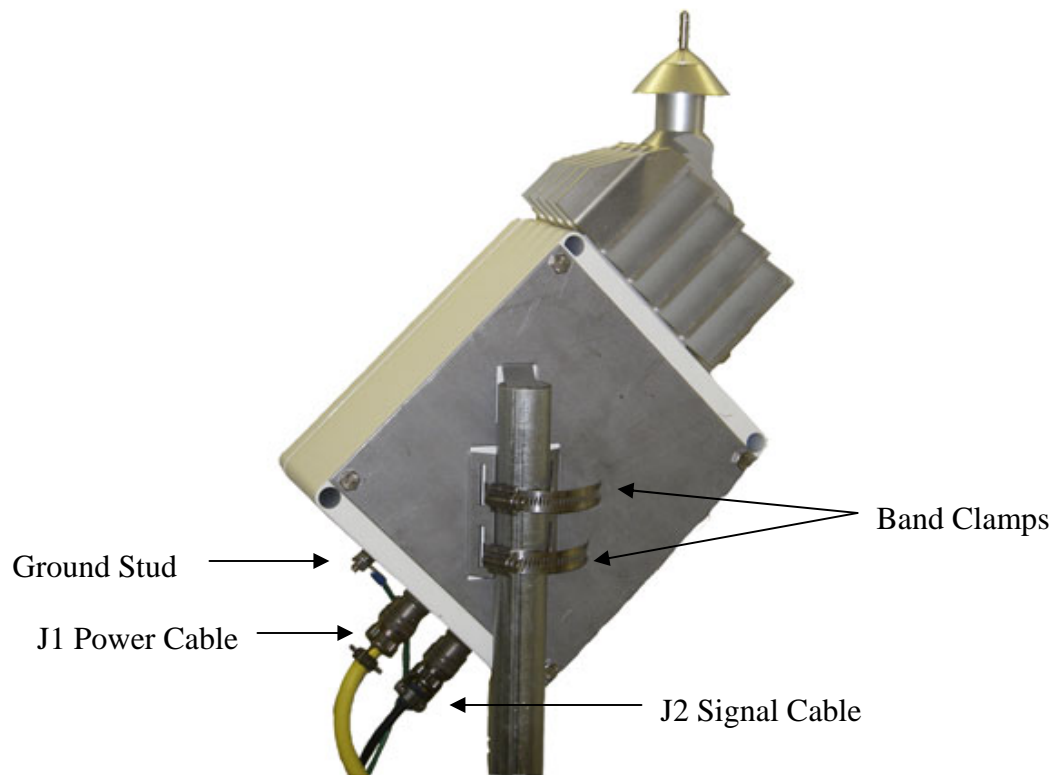

Figure 2. Mounting

2. Remove one ground stud nut.
3. Position ground wire on ground stud.
4. Replace and tighten ground stud nut.
5. Connect cables to connectors J1(IDS) and J2(IDS).
6. Remove protective tube from strut and probe.

3.3 Wiring

Ice Detector Connections	Wire Colour	Description	120 VAC Supply
J1 (pin A)	Black	120 VAC Line	Line
J1 (pin B)	White	120 VAC Neutral	Neutral
J1 (pin C)	Green	120 VAC Ground	Ground
Ground Stud	Green	Ground	Earth Ground

			Datalogger Connections
J2 (pin B)	Green	RS-232 Rx	C1
J2 (pin A)	White	RS-232 Tx	C2
J2 (pin C)	Black	RS-232 Signal Gnd	G
J2	Clear	Shield	G

4 OPERATIONAL CHECK USING DATALOGGER

Before deploying this unit in the field, please perform this quick Operational Check to verify its integrity. The operational check can be performed using the following steps:

1. With the unit removed from the packaging, connect the power and communications cables.
2. Connect the unit to the datalogger using the wiring diagram provided in this manual.
3. After verifying that everything is connected correctly, remove the protective sleeve and probe cover, then apply power to the unit and the datalogger.
4. Using Loggernet or similar connection software, load the following program into the datalogger.

```

"Declare Public Variables
Public Frequency as String
Public IDS_Status as String
Public Heating as String

'Main Program
BeginProg
SerialOpen (Com1,2400,0,0,10000)

    Scan (30,Sec,0,0)

    'Send command for frequency data
    SerialOut (Com1,"Z1", "",0,100)
    Delay (0,5,Sec)
    'Clear buffer
    SerialFlush (Com1)
    'Accept data
    SerialIn (Frequency,Com1,100,0,100)

    'Send diagnostic command
    SerialOut (Com1,"Z4", "",0,100)
    Delay (0,15,Sec)
    'Clear buffer
    SerialFlush (Com1)
    'Accept data
    SerialIn (IDS_Status,Com1,100,0,100)

    'Send command to de-ice strut & probe for 2 seconds
    SerialOut (Com1,"Z302", "",0,100)
    Delay (0,5,Sec)
    'Clear buffer
    SerialFlush (Com1)
    'Accept data
    SerialIn (Heating,Com1,100,0,100)

    NextScan
EndProg

```

5. Using the numeric screens in Loggernet, add the public variables to the display. To do this, click and drag public to the upper left cell in the display. This will paste all three public strings into the view. It will take up to 30 seconds to see results.
6. The following is the expected results for an operational unit. If you receive these results, the unit is ready for field installation.

Frequency	*ZPxxxxxyy
IDS_Status	ZP E3 – IDS passes extended checks
Heating	ZDOK51

*xxxxx is frequency (39970 – 40030 Hz) and yy is the Checksum.

5 PROGRAMMING EXAMPLE FOR CR1000

```
'Declare Public Variables
Public MainString As String * 30
Public Freq_Str As String
Public Frequency As Float
Public CSum As String
Public Status As String
Public Ice      'Default units are in inches
Public Ice_mm   'Ice accumulation in millimeters
Public T109
Public HeatTime

Const Threshold = 0.02 'The icing threshold be be changed based on requirements.
'Note: The recommended min threshold for de-icing is 0.02 inches of ice, and the max is 0.16 inches of ice.

'Define Data Tables
DataTable (IceAcc,True,-1)
  Sample (1,Ice_mm,IIEEE4)
  Sample (1,Ice,IIEEE4)
EndTable

'Main Program
BeginProg
  SerialOpen (Com1,2400,0,0,1000)
  Scan (10,Sec,0,0)

  'Clear buffer before sending commands
  SerialFlush (Com1)

  'Send serial out command to request frequency information
  SerialOut (Com1,"Z1","",0,0)

  'Send serial in command to read information form datalogger buffer.
  SerialIn (MainString,Com1,100,0,100)

  'The following instructions is used to parse the received string.
  Freq_Str = Left (MainString,11)
  Freq_Str = Right (Freq_Str,5)
  Status = Left (MainString,6)
  Status = Right (Status,3)
  CSum = Left (MainString,13)
  CSum = Right (CSum,2)
  Frequency = Freq_Str

  'Formula used to convert the Frequency into Ice Thickness (inches).
  Ice = -0.00015*Frequency + 6

  'Convert ice accumulation from inches to millimeters
  Ice_mm = Ice * 25.4

  'Used to make sure we do not have negative Ice thicknesses in data
  If Ice < 0 Then Ice = 0
  If Ice_mm < 0 Then Ice_mm = 0

  'Measure Temperature Sensor to make sure the temperature is less than 5 degrees Celsius
  Therm109 (T109,1,1,Vx1,0,_60Hz,1.0,0)

  'Check to see the temperature is less than 5 degrees Celsius & ice is greater than threshold. If so, turn on heaters
```

```
'long enough to remove any ice accumulation.
If T109 <= 5 AND Ice >= Threshold Then
  HeatTime = 214.29 * Ice + 5.7142
  HeatTime = INT (HeatTime)

  'If the heat time is calculated higher than 45 seconds, heat for only 45 seconds.
  'NOTE: The heater time is limited to 45 seconds based on the time required to melt
  ' the recommended maximum allowable icing of 4mm (0.16 inches) on the sensing element.
  If HeatTime > 45 Then HeatTime = 45

  'Store icing event data. Calling "IceAcc" table is temperature dependant.
  CallTable IceAcc

  'Heat sensing element for prescribed time calculated in "HeatTime" variable
  SerialOut (Com1,"Z3"+HeatTime,"",0,100)
EndIf

NextScan
EndProg
```

1 APPENDIX A

1.1 SAFETY SUMMARY

1.1.1 Definitions

The following definitions apply to WARNINGS and CAUTIONS found throughout this publication.

1.1.2 Warning

An operation or maintenance procedure, practice, condition, statement, etc., which, if not strictly observed, could result in injury, death, or long term health hazards to personnel.

1.1.3 Caution

An operating or maintenance procedure, practice, statement, etc., which, if not strictly observed, could result in damage/destruction of equipment or loss of mission effectiveness.

1.1.4 Warning

The ground stud must **ALWAYS** be connected to a ground cable when connecting J1(IDS) or applying power to the unit.

1.1.5 General Precautions

The following are general safety precautions that are not related to any specific procedure and therefore do not appear elsewhere in this procedure. These are recommended precautions that personnel shall understand and apply during many phases of operation and maintenance.

1.1.6 Cleaners/Chemicals

Keep in approved safety containers and in minimum quantities. Some cleaners / chemicals may have an effect on skin, eyes and respiratory tract. Observe manufacturer's WARNING labels and current safety directives. Use only in authorized areas. Discard soiled cleaning cloths into safety cans. Unless otherwise indicated in the text, use as described in this manual should not result in any immediate health concerns. Consult the local Bioenvironmental Engineer for specific protective equipment and ventilation requirements.

1.1.7 Compressed Air

Use of compressed air can create an environment of propelled foreign particles. Air pressure not to exceed 15 psi and used with effective chip guarding and personal protective equipment.

1.1.8 Keep Away From Live Circuits

Operating personnel must at all times observe safety regulations. Do not replace components or make adjustments inside the equipment with the voltage supply turned on.

1.1.9 Do Not Service or Adjust Alone

Do not attempt internal service or adjustment unless another person capable of rendering aid and resuscitation is present.

1.1.10 Resuscitation

Personnel working with or near dangerous voltage shall be trained in modern methods of resuscitation. Information and training sources may be obtained from the Director of Base Medical Services.

1.1.11 Electrostatic Discharge (ESD)

Certain circuit card assemblies and their components are susceptible to electrostatic discharge/ damage. Care must be exercised during handling/repair of these items. Use electrostatic discharge (ESD) precautionary procedures.

1.1.12 Environmental Limitations

The 0872F1 is designed for outdoor use in areas that receive inclement weather. Its operation limit is as follows:

<i>Environmental Conditions</i>	<i>Operational Test Limit</i>
High Temperature	50°C
Low Temperature	- 50°C
Humidity	74% RH @ 35°C to 100% RH @ 25° C
Wind (Steady)	to 30 kts

Wind (Gust)	to 46 kts
Rain	3"/hr with 30 kts wind
Freezing Rain	Ice accretion to 1 inch with 20 kt wind at a rate of 1/2 inch per hour
Dust	Exposure to dust laden environment
Low Pressure	to 15.7 in Hg
Ingress Protection	IPX4

1.2 Operation

Apply power to the 0872F1. Wait 30 seconds minimum, then perform the following sequence of commands to ensure proper operation of the unit.

Command	Response	Wait (minimum)
Z1	Zpxxxxxyy	5 sec
Z4	ZP E3	15 sec
Z302	ZDOK51	5 sec

*xxxxx is frequency (39970-40030 Hz) and yy is the checksum

1.3 System Operation

Ice is sensed due to the effect of mass loading on the probe. As ice bonds to the probe the probe mass increases and its natural frequency decreases. The sensor outputs a normalized frequency (corresponding to the ice accretion level) that has been averaged over one minute. The 0872F1 will respond when interrogated by the host system with one of the four different requests described below:

- Z1 – SEND FREQUENCY DATA
- Z3 – DE-ICE STRUT AND PROBE
- Z4 – PERFORM EXTENDED DIAGNOSTICS
- F5 – PERFORM FIELD CALIBRATION

1.4 Data Link

The 0872F1 is interrogated once per minute by the host system. The host system sends ASCII characters to the 0872F1 and awaits the appropriate response. Control characters and control procedures are

compatible with ANSI X3.28 and ANSI X3.66, respectively. The data format consists of the following:

- 1 Start Bit
- 8 Data Bits
- 1 Stop Bit
- No Parity
- 2400 Baud
- Full Duplex
- Serial Asynchronous
- Configured as Data Terminal Equipment (DTE)

Either RS-232 or digital current loop interface can be used to communicate with the 0872F1.

1.5 System Commands

****note: all system commands must be in upper case.**

Z1 – Typing Z1 commands the 0872F1 to “Send Routine Data”. The expected output from the 0872F1 is:

ZPXXXXXXCC Normal Operation
ZDXXXXXXCC De-icing Cycle

“XXXXXX” is the probe frequency (averaged over one minute) and “CC” is the checksum.

The probe frequency must be between 38,400 and 41,500 Hz. Three failure response outputs are also possible after a Z1 command:

ZF1XXXXXXCC Probe Failure
ZF2XXXXXXCC Heater Failure
ZF3XXXXXXCC Electronics Failure

Z3 – Typing “Z3XX” Commands the 0872F1 to turn the strut and probe heaters on for “XX” seconds, where “XX” is a two digit number between 01 and 60. The expected output for the 0872F1 is:

ZDOK51 Confirmation of Heater Activation

If a heater failure is detected or if “XX” is not a valid input, the 0872F1 will not acknowledge the “Z3” request.

WARNING

Probe will become hot during and shortly after heater activation. Sever burns may result if probe is contacted during this time.

CAUTION

Heater activation during test must not exceed 5 seconds if the ambient temperature is greater than 5°C or damage to the probe may result.

Z4 – Typing “Z4” commands the 0872F1 to perform extended diagnostics. The possible outputs from the 0872F1 are:

ZP E3 0872F1 Passes
ZD D7 0872F1 in De-ice Mode
ZF1 EA Probe Failure
ZF2 EB Heater Failure
ZF3 EC Electronics Failure

F5 – Typing “F5” commands the 0872F1 to re-calibrate the probe frequency. The 0872F1 responds with:

Recalibrate? Y or N

Responding with “Y” will recalibrate the nominal probe frequency to 40,000 Hz. Responding with “N” or no response within 10 seconds will cancel the F5 request.

****note: Probe calibration should only be done under the conditions specified in Paragraph 1.8.7 (Field Calibration).**

1.6 Failure Detection

The 0872F1 continuously monitors the following functions:

- Power Supply Voltage
- Memory and Storage Checksums
- Probe Frequency within Operating Range
- Timing
- I/O Port Operation

In addition, the heater control circuit is checked once every ten hours and whenever a Z3 or Z4 command is received.

All failures are logged into a non-volatile RAM circuit and can be read out at the factory using a RS-232 data request. After factory repair, this data is cleared from the non-volatile RAM memory.

1.7 Probe Frequency Variation

It is normal for the 0872F1 frequency (returned after a “Z1” command) to vary slightly due to the effects of temperature, even in non-icing conditions. The frequency can vary up to 15 Hz due to changing ambient temperature. Greater frequency variation is possible during, and shortly after, the heaters have been activated. The frequency will return to normal as the probe cools.

1.8 Electrical Design

1.8.1 Electrical Input Requirements

The ice detector utilizes 115 VAC (103.5 to 126.5 VRMS), 50 to 60 hertz input power. Normal operation continues for power interruptions of less than 10 milliseconds. Power interruptions greater than 10 milliseconds will cause the 0872F1 to go into a reset condition. Under this condition, the 0872F1 will resume operation automatically after the power is reapplied, going through the power-up test sequence.

1.8.2 Power Consumption

Power consumption under the stated supply voltage conditions are shown below:

Mode	Maximum Power Consumption
Monitoring	10 Watts
Detection (no heater power)	10 Watts
De-Icing	385 Watts
Failure	10 Watts

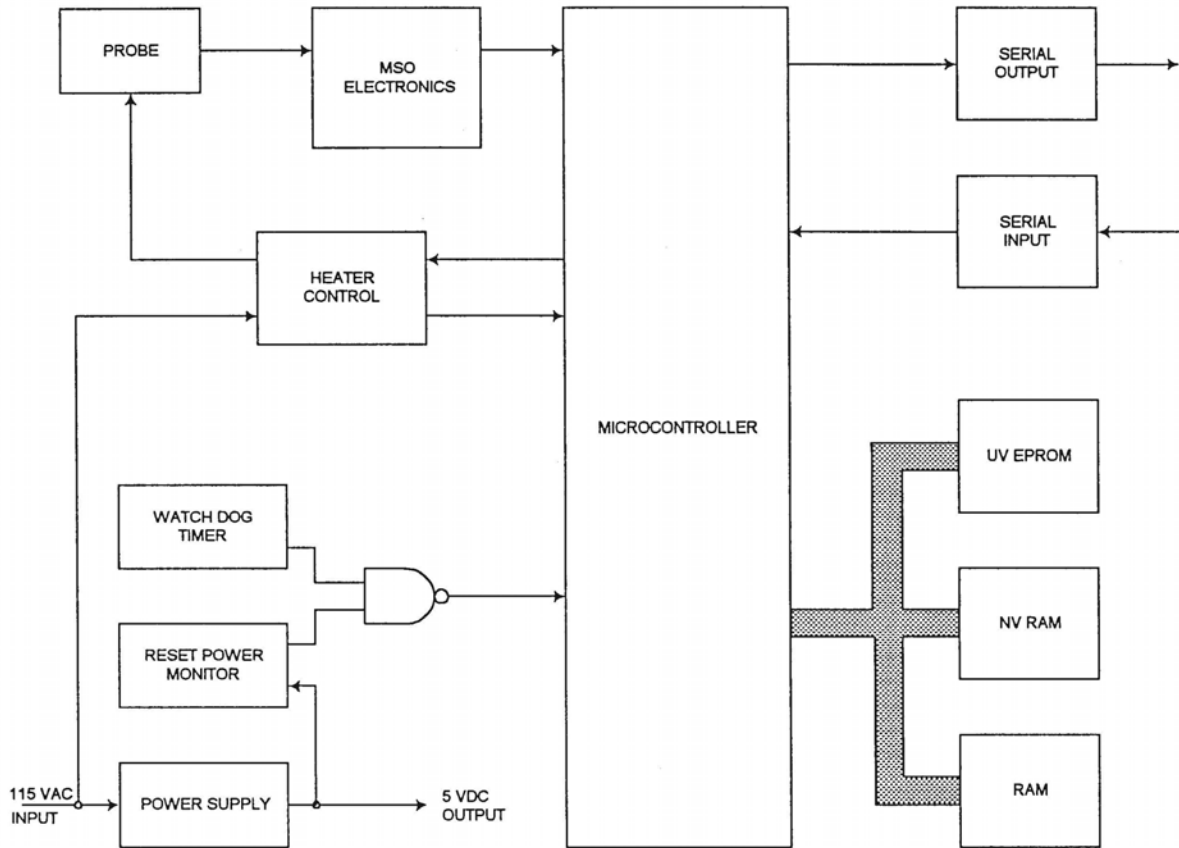

Figure 3. Electrical Block Diagram

Internal Electronics Block	Function
Microcontroller	Performs the ice detection and BIT functions
Heater Control	Activates probe/strut de-icing
Watch Dog Timer/Reset Power Monitor	Monitors internal power supply voltages and power disruptions. Checks microcontroller for operation
Solid-State Power Supply	Provides +5 VDC to unit
Serial Output	Provides RS-232 and digital current pulse
Serial Input	Receives RS-232 and digital current pulse
EPROM/NV-RAM/RAM	Various memories needed for operation of microcontroller

1.9 Maintenance

1.9.1 Maintenance Concept

The maintenance concept for the 0872F1 consists of:

- BIT detecting and isolating a 0872F1 fault to one of three subassemblies.
- Replacement of the faulty subassembly (with 0872F1 attached to the mounting pole).
- Return failed subassembly to Campbell Scientific Canada for repair

1.9.2 Calibration and Preventative Maintenance

The sensor is designed to require no adjustments, alignments, scheduled maintenance, or preventative maintenance. A field calibration feature is included in the design, but the calibration is not performed on a scheduled basis.

****note: probe calibration should only be done under the conditions specified in Paragraph 1.8.7 (Field Calibration).**

1.9.3 Fault Isolation

Failures can be broken into two categories: BIT detected failures, and those that BIT does not detect (non BIT failures).

1.9.3.1 BIT Detected Failures

ZF1 Probe Failure

If a ZF1 failure is indicated in response to the Z1 or Z4 command, proceed as follows:

1. Perform steps 1-6 of paragraph 1.8.5.3 (removal of strut and probe assembly) to electrically disconnect probe from Main CCA.
2. Connect a functional strut and probe assembly to J3(MAIN) and J4(MAIN) on the Main CCA. Install select capacitor (for

3. Turn power to the 0872F1 “On” and wait for 30 seconds. Issue the Z4 command. If the ZF1 failure code is still indicated, replace the Main CCA. If the failure is not longer indicated, replace the strut and probe assembly.

ZF2 Heater Failure

If a ZF2 failure is indicated in response to the Z1 or Z4 command, or if a “no response” condition occurs after issuing the Z3 command, proceed as follows:

1. Perform steps 1-6 of paragraph 1.8.5.3 (removal of strut and probe assembly) to electrically disconnect probe from Main CCA.
2. Check resistance between J4(S/P)-1 and J4(S/P)-2 using an ohmmeter. Resistance must be 42 ± 5 ohms. If resistance is within range, replace Main CCA. If resistance is out of range, replace strut and probe assembly.

ZF3 Electronic Failure

If a Zf3 failure is indicated in response to the Z1 or Z4 command, replace the Main CCA. No further troubleshooting is required.

1.9.3.2 Non BIT Failures

If the sensor fails to respond to commands, proceed as follows:

1. Verify AC power is on and main J1(IDS) and J2(IDS) connectors are connected to the IDS.
2. Switch to RS-232 mode. If the 0872F1 communicates in RS-232 mode, but not is current loop mode, replace the Output Interface CCA. If the 0872F1 fails to communicate in either mode, continue with step 3.
3. Switch AC power off. Disconnect connector J1(IDS). Using an ohmmeter, measure the resistance between connector J1(IDS)-A and J1(IDS)-B. If resistance is less than 200 ohms, replace Main CCA. If not, loosen four cover screws and open cover. Remove plastic guard covering J1(MAIN) terminal block by depressing three white clips on each side of guard. Measure resistance between J12(MAIN) pins 1 and 2. If resistance is less than 200 ohms, replace Filter Assembly. If greater than 200 ohms, replace Main CCA.

1.9.4 Removal of 0872F1

Most repairs can be accomplished without removing the 0872F1 from the mounting pole. If removal is required, proceed as follows:

1. Switch 115 VAC power to 0872F1 off.
2. Place protective tube over strut and probe.
3. Disconnect connectors J1(IDS) and J2(IDS). Place ESD protective caps over connectors.
4. Remove ground nut and wire from ground stud. Put nut back on finger tight.
5. Loosen mounting bolts and remove unit from mounting pole.

1.9.5 Disassembly

1.9.5.1 Removal of Output Interface CCA

Refer to Figure 3 for removal of Output Interface CCA.

WARNING

Remove power to unit prior to opening sensor cover or injuries could result from electrical shock.

CAUTION

This is a Class 1 ESDS item. ESD precautions must be taken prior to opening sensor cover or equipment damage could result.

1. Switch 115 VDC power to the 0872F1 off. Disconnect J1(IDS).
2. Loosen captive screws on sensor cover.
3. Open sensor cover. Cover is hinged to housing. (Pull cover up, then back to open.)
4. Carefully disconnect J1(I/O) and J2(I/O) plugs from Output Interface CCA.
5. Remove green ground wire from case.
6. Remove Output Interface CCA by gently pulling off from Main CCA.

1.9.5.2 Removal of Main CCA

Refer to Figures 3 and 4 for removal of Main CCA.

WARNING

Remove power to unit prior to opening sensor cover or injuries could result from electrical shock.

CAUTION

This is a Class 1 ESDS item. ESD precautions must be taken prior to opening sensor cover or equipment damage could result.

1. Switch 115 VAC power to 0872F1 off. Disconnect J1(IDS).
2. Loosen captive screws on sensor cover.
3. Open sensor cover. Cover is hinged to housing (pull cover up, then back to open.)
4. Remove Output Interface CCA per paragraph 1.9.5.1.
5. Remove plastic terminal block cover mounted on snap-on standoffs.
6. Remove terminal screws #1, #2, and #3 with a flat-tip screwdriver. The lugs on these wires are closed-ended.
7. Carefully remove select capacitor C7. Depress latch and pull capacitor straight upward. (This capacitor will be reinstalled on the replacement CCA.)
8. Carefully disconnect J2(MAIN), J3(MAIN), and J4(MAIN) plugs from main CCA.
9. Remove two remaining wires from terminal block (see Figures 3 and 4).
10. Remove Main CCA mounting screws.
11. Remove Main CCA from sensor housing.

1.9.5.3 Removal of Strut and Probe Assembly from Heat Sink

Refer to Figure 3 for removal of strut and probe assembly from heat sink.

WARNING

Remove power to unit prior to opening sensor cover or injuries could result from electrical shock.

CAUTION

This is a Class 1 ESDS item. ESD precautions must be taken prior to opening sensor cover or equipment damage could result.

****note: Strut and probe replacement can be done at any ambient temperature, however, the unit should be field calibrated only when the ambient temperature is between -10°C and +10°C (see paragraph 1.8.7).**

1. Switch 115VAC power to 0872F1 off. Disconnect J1(IDS).
2. Place protective tube over strut and probe.
3. Loosen captive bolts on sensor cover.
4. Open sensor cover. Cover is hinged to housing (pull cover up, then back to open).
5. Carefully remove select capacitor C7. Depress latch and pull capacitor straight out.
6. Carefully disconnect connectors P3(I/O) and P4(I/O) from J3(MAIN) and J4(MAIN). Remove black grommet from hole in top of housing. **NOTE: Some early units have a small amount of silicone RTV sealing the hole in the housing in place of the grommet. The RTV should be carefully removed prior to strut removal so that the connectors can be routed through the housing and heat sink.**
7. Remove four strut mounting screws securing strut to heat sink.
8. Remove strut and probe assembly from heat sink. Carefully feed connectors through the housing and heat sink as the strut is removed.
9. Remove and examine strut and probe O-ring.

1.9.5.4 Removal of Programmed EPROM

WARNING

Remove power to unit prior to opening sensor cover or injuries could result from electrical shock.

CAUTION

This is a Class 1 ESDS item. ESD precautions must be taken prior to opening sensor cover or equipment damage could result.

1. Switch 115VAC power to 0872F1 off. Disconnect J1(IDS).
2. Loosen captive bolts on sensor cover.
3. Open sensor cover. Cover is hinged to housing (pull cover up, then back to open.)
4. Remove Output Interface CCA per paragraph 1.9.5.1.
5. The EEPROM is located in the lower left corner of the Main CCA. It is distinguished from other components by the socket eject levers used to secure and remove the component from the socket. Push tabs on socket eject levers outward to lift and remove EEPROM from Main CCA.

1.9.5.5 Removal of Filter Assembly

Refer to Figures 3 and 4 for removal of Filter Assembly.

WARNING

Remove power to unit prior to opening sensor cover or injuries could result from electrical shock.

CAUTION

This is a Class 1 ESDS item. ESD precautions must be taken prior to opening sensor cover or equipment damage could result.

1. Switch 115VAC power to 0872F1 off. Disconnect J1(IDS) and J2(IDS).
2. Loosen captive bolts on sensor cover.
3. Open sensor cover. Cover is hinged to housing (pull cover up, then back to open).
4. Remove jam nut securing J1(IDS) connector to housing.
5. Disconnect wires from line filter at terminal block J1(MAIN), terminals 1 and 2.
6. Disconnect green/yellow wire (originating at line filter) from ground stud.
7. Remove two shoulder nuts securing line filter to housing.
8. Remove J1(IDS) connector and line filter from housing.

1.9.6 Assembly

Refer to Figures 3 and 4 for installation of FRUs.

1.9.6.1 Installation of Main CCA

1. Ensure that 115VAC power to 0872F1 is off and J1(IDS) is disconnected.
2. Install Select Capacitor C7 into replacement Main CCA.
3. Position Main CCA into housing with terminal block to the bottom side (ground lug side) of the housing.
4. Install Main CCA mounting screws.
5. Install latching electrical connectors J2(MAIN), J3(MAIN) and J4(MAIN).
6. Position wires on terminal block and tighten terminal screws.
 - Blue wire to terminal #1
 - White wire from terminal #1 to terminal #4
 - Brown wire to terminal #2
 - Black wire from terminal #2 to terminal #5
 - Green wire (from ground stud) to terminal #3
7. Torque terminal block screws to 9 in-lbs.
8. Snap lastic terminal block cover in place.
9. Install Output Interface CCA per paragraph 5.6.2.
10. Position cover on housing.
11. Torque cover mounting screws to 28 in-lbs.
12. Perform “System Verification” (paragraph 1.8.8).

1.9.6.2 Installation of Output Interface CCA

1. Ensure that 115VAC power to 0872F1 is off.
2. Align four plastic standoffs with corresponding holes on Main CCA and snap in place.
3. Install green ground wire to internal ground stud.
4. Install plugs J1(I/O) and J2(I/O) in receptacles on Output Interface CCA.
5. Perform “System Verification” (paragraph 1.8.8).

1.9.6.3 Installation of Strut and Probe Assembly

1. Ensure that 115VAC power to 0872F1 is off and J1(IDS) is disconnected.
2. Replacement select capacitor is provided with the spare strut and probe assembly. Install select capacitor into Main CCA location C7.
3. Install O-ring in channel in strut. Feed probe and heater wires through heat sink into housing.
4. Carefully position strut and probe assembly on heat sink taking care not to pinch any wires.

5. Secure strut and probe assembly to heat sink with four screws. Torque to 12 in-lbs.
6. Connect probe electrical connectors P3(I/O) and P4(I/O) at J3(MAIN) and J4(MAIN).
7. Route wires through grommet and press grommet into hole in top of hole (about two-thirds of grommet should be inside hole).
8. Position cover on housing.
9. Torque cover mounting screws to 28 in-lbs.
10. Remove protective tube from strut and probe.
11. Perform “System Verification” (paragraph 1.8.8).

1.9.6.4 Installation of Programmed EPROM

1. Ensure that 115VAC power to 0872F1 is off and J1(IDS) is disconnected.
2. Orient replacement EPROM so that the notch faces the same direction as other integrated circuits on the CCA. Push EPROM evenly into socket until it is fully seated and eject levers clamp into place. **NOTE: It may be necessary to squeeze the eject levers together slightly to fully seat the EPROM.**
3. Install Output Interface CCA per paragraph 1.8.6.2
4. Perform steps 10 and 11 of paragraph 1.8.6.1 (Installation of Main CCA).
5. Perform “System Verification” (paragraph 1.8.8).

1.9.6.5 Installation of Filter Assembly

Refer to Figures 3 and 4 for installation of filter assembly.

1. Install line filter onto housing studs so that side of filter with two leads faces down
2. Secure line filter to housing using lockwasher and shoulder nut (two places). Torque to 8 in-lbs.
3. Remove jam nut from connector. Insert connector through D-hole in housing and secure with jam nut. **NOTE:** Ensure connector O-ring remains in the groove. Torque jam nut to 80 in-lbs.
4. Perform “System Verification” (paragraph 1.8.8).

1.9.7 Field Calibration

Field Calibration of the 0872F1 may be required after replacement of the Strut and Probe Assembly or Main CCA. Field calibration should be invoked if the “Z1” frequency of a clean and dry probe at $0 \pm 10^{\circ}\text{C}$ is less than 39970 Hz or greater than 40030 Hz.

Calibration should not be performed under any of the following conditions:

- Temperature is greater than 10°C or less than -10°C .
- Freezing rain or snow has accreted on the sensing probe.
- Liquid water or other contaminants are visible on the probe.
- Within 20 minutes of a “Z3” (de-ice) command.
- Z1 or Z4 commands indicate a fail condition

1.9.7.1 Calibration Procedure

1. Insure temperature is $0 \pm 10^{\circ}\text{C}$ and the probe is clean and dry.
2. Type “F5”.
3. Type “Y” when prompted.
4. Wait one minute.
5. Type “Z1”. The 0872F1 should respond with “ZPXXXXXY”. “XXXXX” represents the probe frequency and should be between 39995 and 40005.

1.9.8 System Verification

1. Ensure connectors J1(IDS) and J2(IDS) are attached to the 0872F1 and 115VAC power to the 0872F1 is on.
2. Type “Z1”. The 0872F1 should respond with “ZPXXXXXY”. “XXXXX” represents the probe frequency. If probe is clean and dry and the ambient temperature is $0^{\circ} \pm 10^{\circ}\text{C}$, the probe frequency should be between 39970 and 40030.
3. Type “Z4”. The 0872F1 should respond with “ZP E3”.
4. Type “Z302”. The 0872F1 should respond with “ZDOK51”.

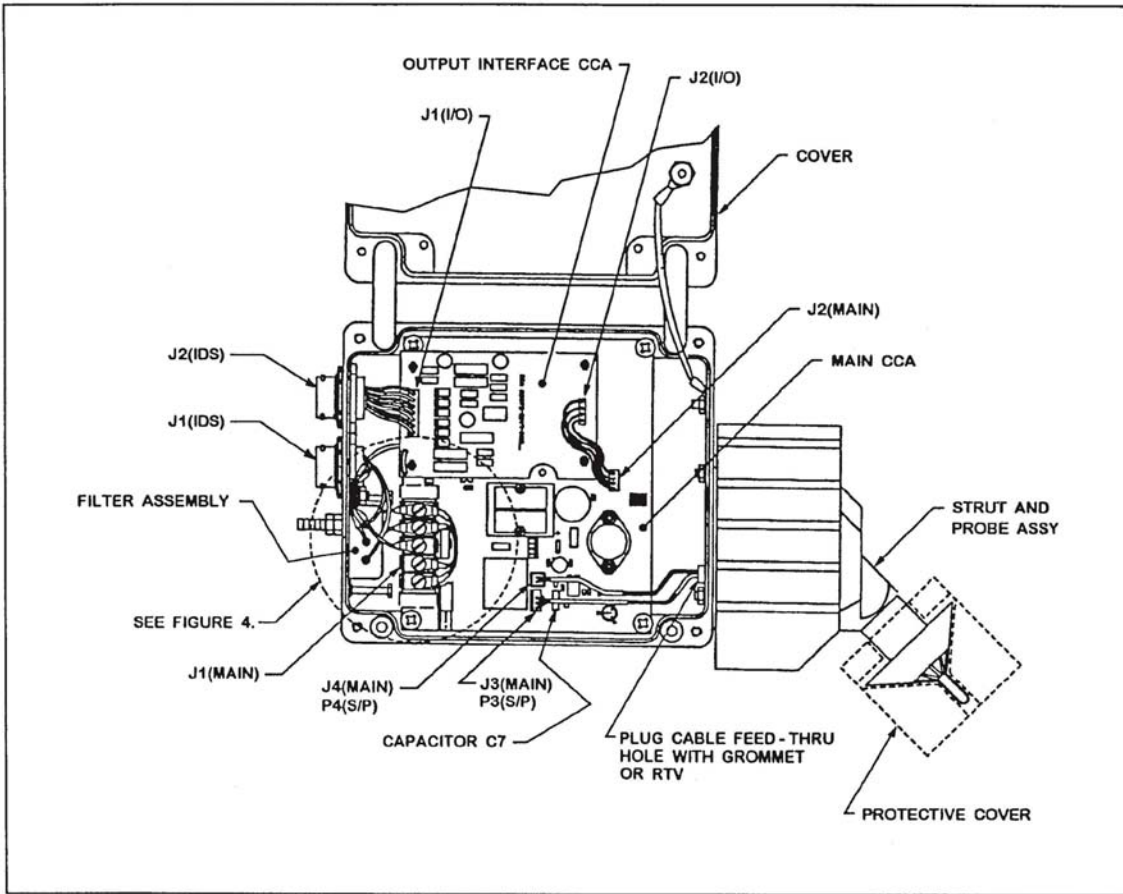

Figure 4. Assembly Drawing

FIELD REPLACEABLE ASSEMBLIES

Item Name	Manufacturer's Part Number	CAGE Code
Main CCA	00872-0330-003	59885
Output Interface CCA	00872-0149-0003	59885
Strut and Probe Assembly	00872-0391-0001	59885
Filter Assembly	00872-0319-0001	59885
Programmed EPROM	00872-0270-0002	59885

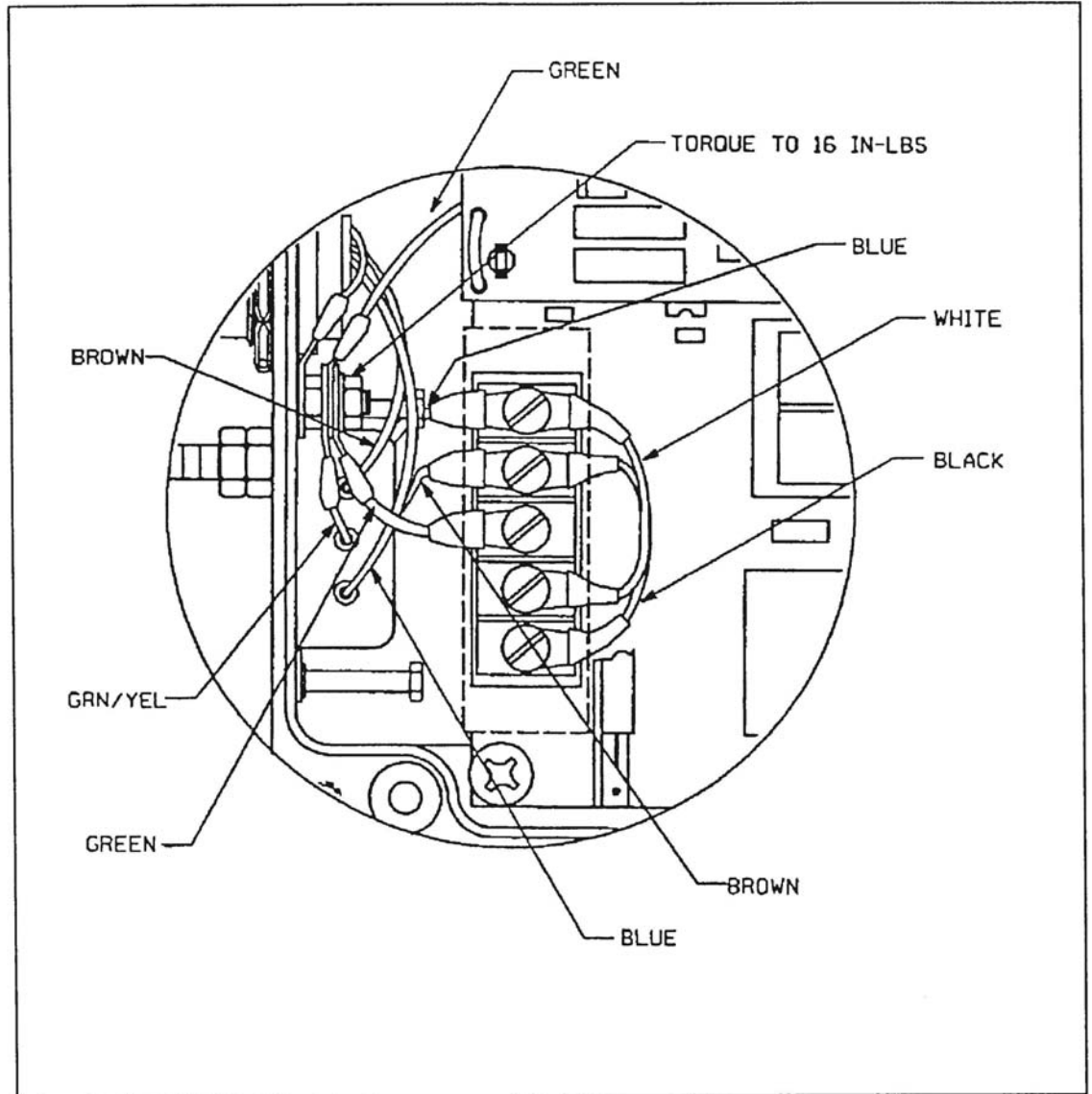

Figure 5. Detail Assembly Drawing

1.9.9 Output Interface Circuit

The Output Interface CCA contains all the necessary electronics to convert the RS-232 signal from the Main CCA to a current pulse output. Standard RS-232 output is also available.

1.9.10 Electrical Connections

Electrical Connections to the 0872F1 are made at the two main unit connectors located on the outside of the housing. Connector J1(IDS) connects power to the 0872F1. J2(IDS) connects the RS-232 and current loop signal lines to the 0872F1.

J1(IDS) Power Connector	
Pin	Description
A	115 VAC Hot
B	115 VAC Neutral
C	Case Ground

J2(IDS) Power Connector	
Pin	Description
A	RS-232Tx
B	RS-232Rx
C	RS-232 Signal Gnd.
D	Unused
E	Unused
F	Current Loop Rx+
G	Current Loop Rx-
H	Current Loop Tx+
J	Current Loop Tx-
K	Unused

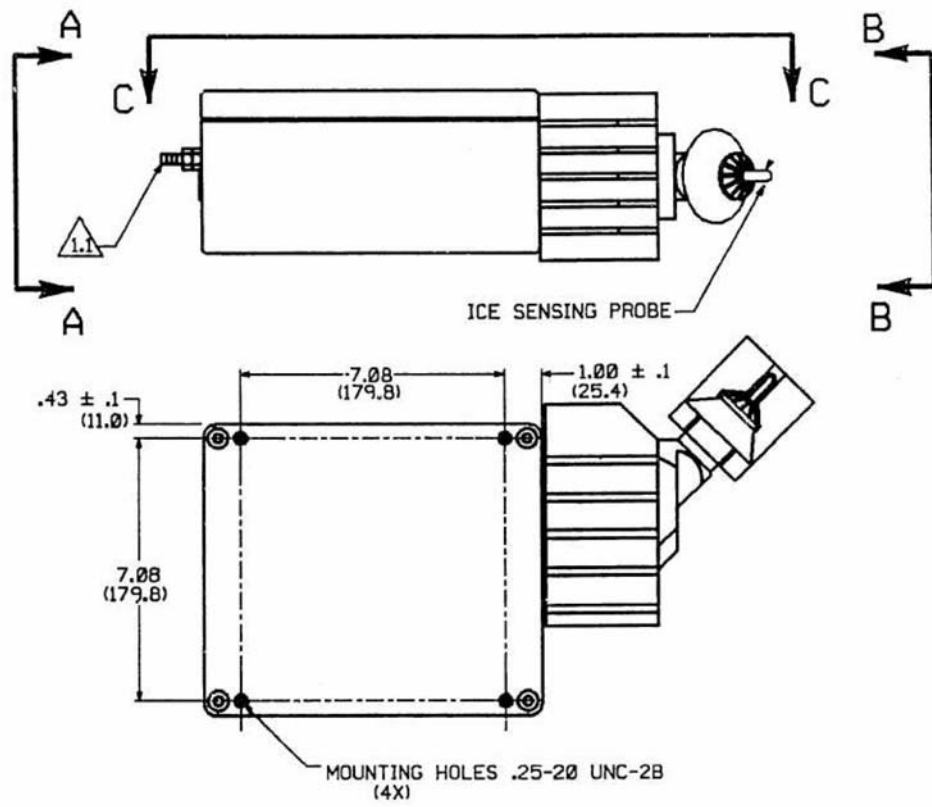

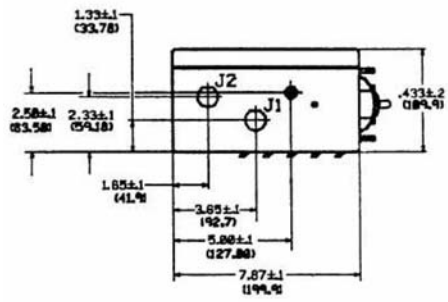

VIEW A-A

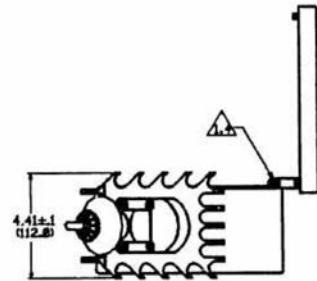

VIEW B-B

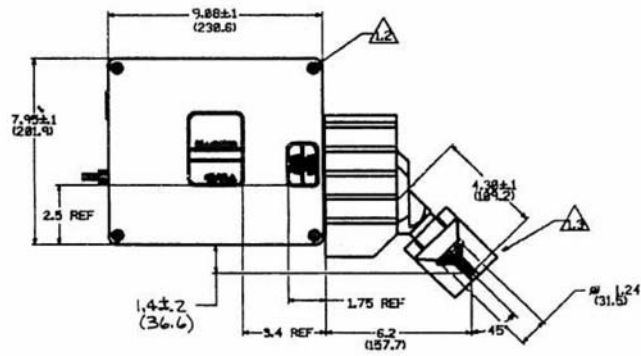

VIEW C-C

2 APPENDIX B

2.1 EC Declaration Certificate

EC DECLARATION OF CONFORMITY

Rosemount Aerospace, Inc. a wholly-owned subsidiary of the Goodrich Corporation,
operating as Goodrich Sensors and Integrated Systems

of 14300 Judicial Road; Burnsville MN 55306

declares that:

Ice Detector Model No. **0872F1 Mod 1** and
Ice Detector Model No. **0872E3 Mod 1** and
Ice Detector Model No. **0872C3 Mod 1**

in accordance with the following Directives

2004/108/EC Directive

has been designed and manufactured to the following specifications:

EN 61326: 1997 Electrical Equipment for Measurement, Control and
Laboratory Use. - EMC Requirements. Includes:
 Amendment A1: 1998
 Amendment A2: 2001
 Amendment A3: 2003

Rosemount Aerospace, Inc. hereby declares that the equipment named above has
been designed to comply with the relevant sections of the above referenced
specifications. The unit complies with the requirements of the above referenced
Directives as qualified per test reports NC708354.

Ice Detector Manager – Darren Jackson



Date 3-9-09

Quality Assurance – Bill Burkhart



Date 3-12-09



TRANSMITTAL OF TECHNICAL DATA (EAR)

These commodities, technology, or software are controlled by the U.S. Export Administration Regulations
(EAR). Diversion contrary to U. S. law is prohibited.
ECCN: 7E994.