

Campbell Scientific (Canada) Corp. is pleased to present the new  
Goodrich Sensor Systems'

# 0871LH1

## Freezing Rain Sensor

*Designed specifically for ground-based freezing rain sensing*  
*Small size, weighs less than 1 pound*  
*Non de-iced strut lowers power consumption*  
*Simplified design lowers cost*  
*Discrete and RS422 output signals*  
*Commanded and continuous built-in test (BIT)*

To detect the presence of an icing condition, the ice detection probe vibrates ultrasonically at a nominal resonant frequency of 40 kHz. As ice accretes on the probe, the added mass causes the resonant frequency to decrease. When a frequency decrease equivalent to 0.50 mm ice thickness is detected, the ice signals (discrete and RS422 outputs) are activated for a period of 60 seconds and the ice detector initiates a self de-icing cycle that removes all accumulated ice from the probe. If another icing encounter is detected within that 60 second period, the annunciator timer is reset to zero and the ice signals remain activated for an additional 60 seconds.

The 0871LH1 should be mounted at a slight inclination angle of 20 to 30 degrees into the prevailing wind. This will allow for the proper drainage of water at the base of the sensor.



## Set Point

The ice signal activates when probe ice thickness exceeds 0.50 mm ± 0.13 mm

## Operating Modes

Sensing  
De-icing

Operating with no ice or with probe ice thickness below the set point.  
Operating with probe ice thickness exceeding the set point.

## Discrete Output Signals

*Ice Signal:*

No icing: Open

Icing detected: Ground

*Status Signal:*

Operating correctly: Ground

Failure detected: Open

*Output Signal Notes:*

"Open" – impedance is >200k ohms

"Ground" – maximum current sink is 50 mA

## RS-422 Output Signals

*Ice State:* 0 = Ice, 1 = No Ice

*Fail State:* 1 = Fail, 0 = No Fail (OK)

## Commanded Built-In Test (BIT)

Commanded BIT is performed at initial power-up. If a failure is detected and verified, the ice detector stops detecting and annunciating icing conditions, the heaters are disabled, and a failure is annunciated.

## Continuous Built-In Test (BIT)

Hardware and software BIT verifies that internal electronics are functioning properly.

**Output Format** RS422 output operates @ 9600 baud. (see our 0871LH1 Manual for details on RS422 output.)

## Electrical

Input Voltage: 22 to 29.5 VDC

Power Consumption:

- Sensing mode: 15 Watts maximum

- De-Icing mode: 50 Watts maximum

Connector Pinout: See configuration drawing

Random Vibration: 7.9 Grms (DO-160D, Category R)

Shock: MIL 810D METHOD 516

Mechanical Electrical Connector: MS27474T10B99PN

Mating Electrical Connector: MS27473T10B99SN

## Environmental

Operating Temperature Range:

-55°C to +71°C

Storage Temperature Range:

-65°C to +90°C

Weight: 0.7 lbs maximum

## CONFIGURATION DRAWING

### CONNECTOR PINOUTS

Pins	Function
A	28 VDC
B	28 VDC return
C	Case ground
D	RS-422 high
E	RS-422 low
F	Ice signal
G	Status signal

## ORDERING INFORMATION

Order Model Number... 0871LH1 Freezing Rain Sensor

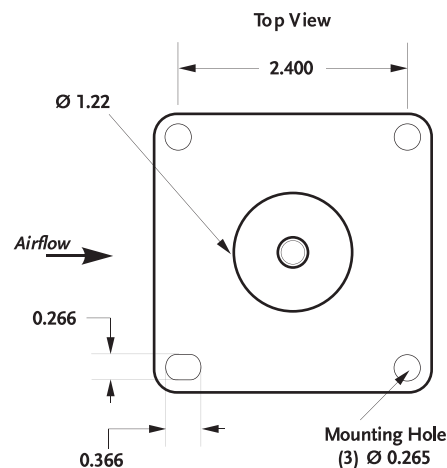
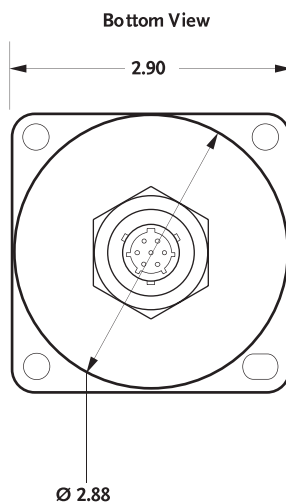

All dimensions in inches

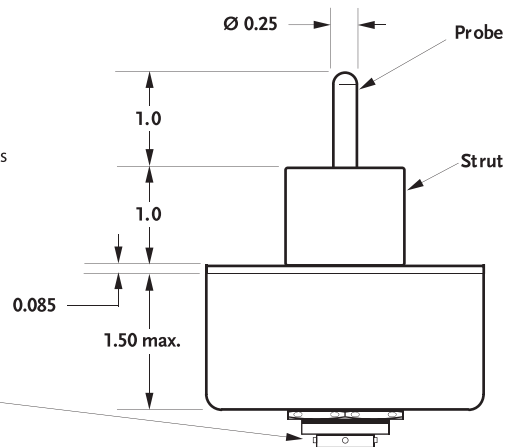

Electrical Connector  
MS27474T10B99P



**CAMPBELL SCIENTIFIC**  
CANADA CORP.

11564 - 149 street - edmonton - alberta - T5M 1W7  
tel 780.454.2505 fax 780.454.2655  
www.campbellsci.ca

rev 02.15.08