

# TIMs

## Terminal Input Modules

Terminal input modules (TIMs) are small peripherals that provide completion resistors for resistive bridge measurements, and act as voltage dividers and precision current shunts. The modules attach directly to the datalogger's input terminals. Each module provides circuitry to connect one sensor, except for the voltage dividers which allow connection of two single-ended sensors. Please note that the legs of our TIMs do not fit on the CR7 datalogger's connectors.

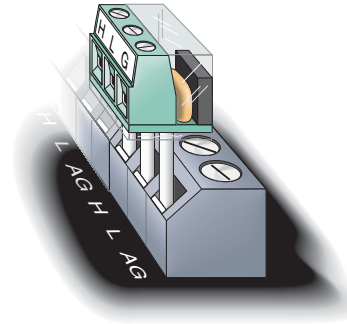

### 3-Wire Half Bridge Module (3WHB10K)

Typically used with 100  $\Omega$  and 1 k $\Omega$  PRTs, the 3WHB10K is designed for 3-wire half-bridge measurements.

#### Specifications

10 k $\Omega$  Completion Resistor ( $R_f$ )  
(bulk metal foil)

Tolerance @ 25°C:  $\pm 0.01\%$

Maximum temperature coefficient:  $\pm 0.8 \text{ ppm } ^\circ\text{C}^{-1}$

Power rating:  
0.25 W @ 70°C

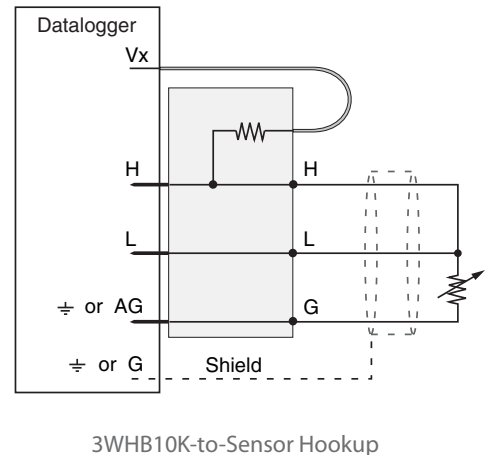
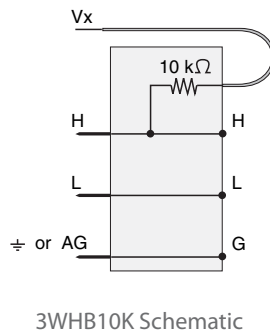

### 4-Wire Half Bridge Module (4WHB10K)

The 4WHB10K provides a completion resistor for 4-wire half bridge measurements. This module should be used with sensors that have a 10 k $\Omega$  resistance.

#### Specifications

10 k $\Omega$  Completion Resistor ( $R_f$ ) (bulk metal foil)

Tolerance @ 25°C:  $\pm 0.01\%$

Maximum temperature coefficient:  $\pm 0.8 \text{ ppm } ^\circ\text{C}^{-1}$

Power rating: 0.25 W @ 70°C

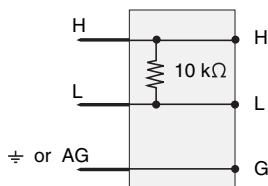

4WHB10K Schematic

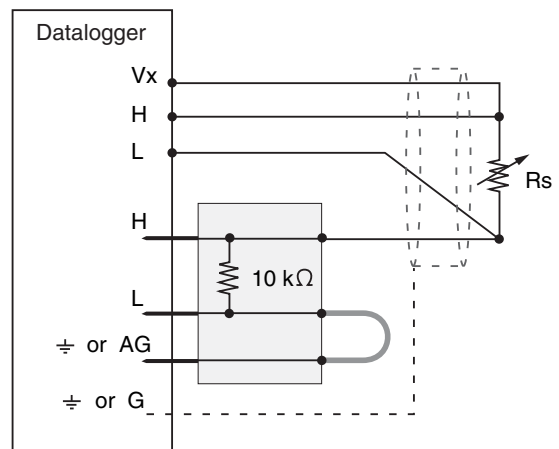

4WHB10K-to-Sensor Hookup

## 4-Wire Full Bridge Modules (4WFB120, 4WFB350, 4WFB1K)

These modules provide completion resistors for strain gage or other full-bridge measurements. The sensor's resistance (R2) and the module's resistance (R1) should match. The modules are available with 120 Ω, 350 Ω, or 1 kΩ resistance. Consult factory for other values.

### Specifications

1:1 Resistive Divider

Resistance (R1 & R2): 1 kΩ & 1 kΩ

Ratio tolerance @ 25°C: ±0.02%

Maximum ratio temperature coefficient:  
2 ppm °C<sup>-1</sup> (0° to 70°C)

Power rating per element: 0.1 W @ 70°C

Completion Resistor (bulk metal foil)

Resistance (R4):

120 Ω (model 4WFB120)

350 Ω (model 4WFB350)

1 kΩ (model 4WFB1K)

Tolerance @ 25°C: ±0.01%

Maximum temperature coefficient:  
±0.8 ppm °C<sup>-1</sup>

Power rating: 0.25 W @ 70°C

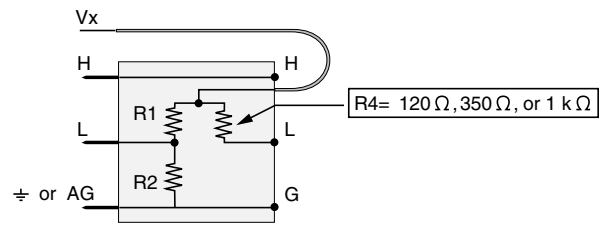

4-Wire Full Bridge Module Schematic

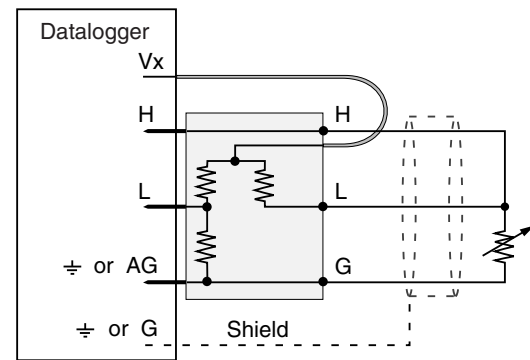

Module-to-Sensor Hookup

## 4-Wire PRT Bridge Modules (4WPB100, 4WPB1K)

These half-bridge modules are designed to provide completion resistors for 100 Ω and 1 kΩ Platinum Resistive Thermometer (PRT) measurements. The PRT's resistance should match the module's resistance (Rf).

### Specifications

Current limiting 10 kΩ Resistor

Tolerance @ 25°C: ±5%

Power rating: 0.25 W

Completion Resistor (bulk metal foil)

Resistance (Rf):

100 Ω (model 4WPB100)

1 kΩ (model 4WPB1K)

Tolerance @ 25°C: ±0.01%

Maximum temperature coefficient: ±0.8 ppm °C<sup>-1</sup>

Power rating: 0.25 W @ 70°C

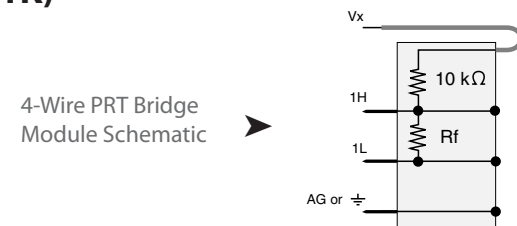

4-Wire PRT Bridge Module Schematic

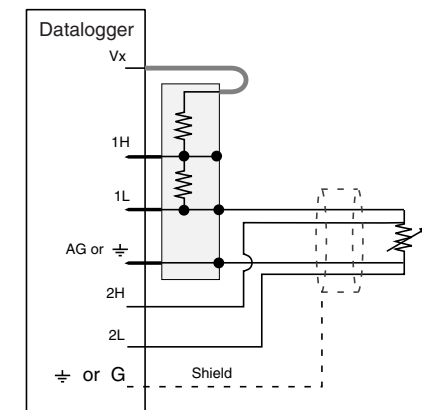

Module-to-Sensor Hookup

## Current Shunt Module (CURS100)

The CURS100 converts a current signal (e.g., 4 to 20 mA) to a voltage measurable by the datalogger. The module uses a 100 Ω resistor allowing currents up to ±25 mA to be read on the ±2500 mV range of a CR510 or CR10X, and currents up to ±50 mA to be read on the ±5000 mV range of a CR800, CR850, CR1000, CR3000, CR5000, or CR9000X.

### Specifications

Shunt Resistor (bulk metal foil): 100 Ω

Tolerance @ 25°C: ±0.01%

Maximum temperature coefficient

0° to 60°C: ±4 ppm °C<sup>-1</sup>

-55° to 125°C: ±8 ppm °C<sup>-1</sup>

Power rating: 0.25 W @ 70°C

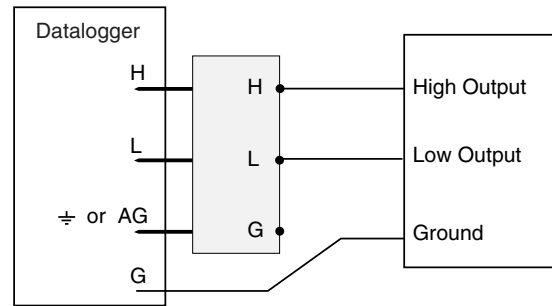
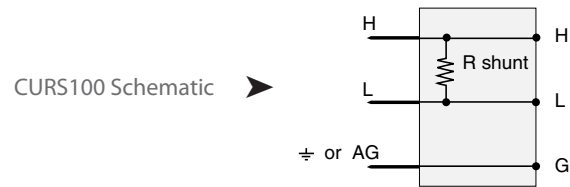

CURS100-to-Sensor Hookup

## Voltage Divider Modules (VDIV10.1, VDIV2.1)

These modules use precision resistor networks to bring sensors with high output voltages into the datalogger's common mode range. The modules divide the sensor's signal voltage by a factor of ten or a factor of two. The maximum input voltage into the 10:1 divider should not exceed ±50 V. Increased input voltage settling time may be necessary to accommodate the relatively high resistances of the 10:1 and 2:1 voltage divider modules.

### Specifications

Division ratio:

10:1 (model VDIV10.1)

2:1 (model VDIV2.1)

Resistors:

90 kΩ & 10 kΩ (model VDIV10.1)

10 kΩ & 10 kΩ (model VDIV2.1)

Ratio tolerance @ 25°C: ±0.02%

Maximum ratio temperature coefficient:

2 ppm °C<sup>-1</sup> (0° to 70°C)

Power rating per element: 0.1 W @ 70°C

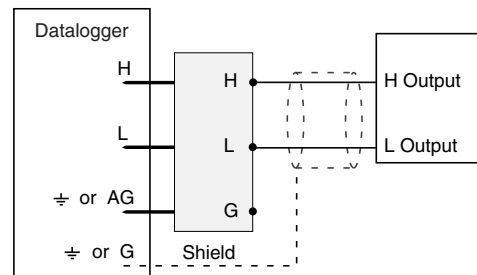
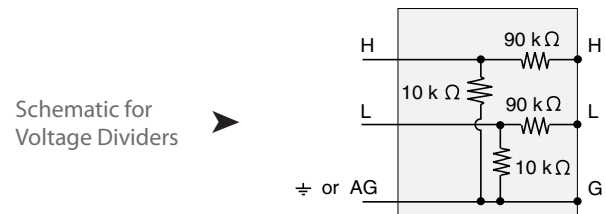

Hookup for one sensor measured differentially

Hookup for two single-ended sensor measurements →

