

INSTRUCTION MANUAL

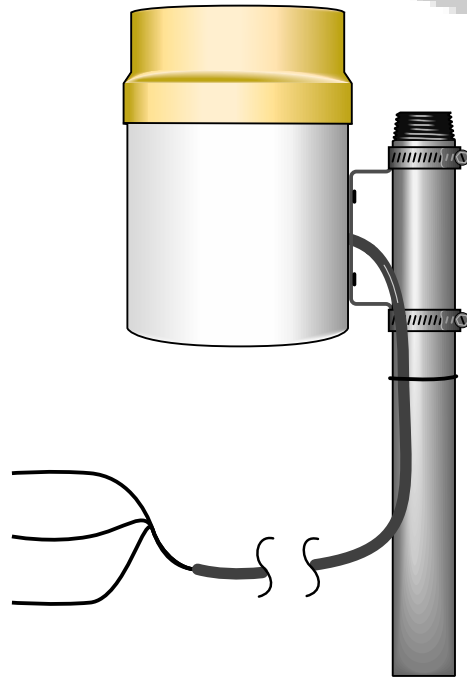

TE525 Tipping Bucket Rain Gage

Revision: 1/10



Copyright © 1990-2008
Campbell Scientific, Inc.

WARRANTY AND ASSISTANCE

This equipment is warranted by CAMPBELL SCIENTIFIC (CANADA) CORP. ("CSC") to be free from defects in materials and workmanship under normal use and service for **twelve (12) months** from date of shipment unless specified otherwise. ***** **Batteries are not warranted.** ***** CSC's obligation under this warranty is limited to repairing or replacing (at CSC's option) defective products. The customer shall assume all costs of removing, reinstalling, and shipping defective products to CSC. CSC will return such products by surface carrier prepaid. This warranty shall not apply to any CSC products which have been subjected to modification, misuse, neglect, accidents of nature, or shipping damage. This warranty is in lieu of all other warranties, expressed or implied, including warranties of merchantability or fitness for a particular purpose. CSC is not liable for special, indirect, incidental, or consequential damages.

Products may not be returned without prior authorization. To obtain a Return Merchandise Authorization (RMA), contact CAMPBELL SCIENTIFIC (CANADA) CORP., at (780) 454-2505. An RMA number will be issued in order to facilitate Repair Personnel in identifying an instrument upon arrival. Please write this number clearly on the outside of the shipping container. Include description of symptoms and all pertinent details.

CAMPBELL SCIENTIFIC (CANADA) CORP. does not accept collect calls.

Non-warranty products returned for repair should be accompanied by a purchase order to cover repair costs.



CAMPBELL SCIENTIFIC
C A N A D A C O R P .

11564 - 149 street - edmonton - alberta - T5M 1W7
tel 780.454.2505 fax 780.454.2655

www.campbellsci.ca

TE525 Table of Contents

PDF viewers note: These page numbers refer to the printed version of this document. Use the Adobe Acrobat® bookmarks tab for links to specific sections.

1. General Description	1
2. Specifications	1
3. Installation	2
3.1 Siting.....	2
3.2 Mounting	3
4. Wiring	4
5. Datalogger Programming	5
5.1 Example Programs.....	6
5.2 CR1000 Example Program	6
5.3 CR10X Example Program	6
5.4 CR200 Series Example Program	7
5.5 Control Port Examples.....	7
5.5.1 CR1000 Example Program	8
5.5.2 C10X Example Program	8
6. Troubleshooting	9
6.1 Precipitation.....	9
7. Maintenance	9

Figures

3-1. TE525 Tipping Bucket Rain Gage	3
3-2. Pedestal Base Options	4
4-1. Rain Gage Schematic	5

Tables

4-1. Wiring for Pulse Channel Input	4
4-2. Wiring for Control Port Input.....	5
5-1. Multipliers for Rain Measurement	5

TE525 Tipping Bucket Rain Gauge

1. General Description

The TE525 is an adaptation of the standard Weather Bureau tipping bucket rain gauge. Output is a switch closure for each bucket tip. Three models are available:

- TE525 6 in. Collector 0.01 in. tip
- TE525WS 8 in. Collector 0.01 in. tip
- TE525M 9.6 in Collector 0.1 mm tip

A “-L” after the model number indicates that the cable length is specified when ordering.

The TE525 ships with:

- (1) Calibration sheet
- (2) Hose clamps from original mfg
- (1) Instruction manual
- (3) Screws from original mfg

2. Specifications

Range of Indication:

Infinite in increments of tip (least count) of rainfall.

Rainfall per Tip

TE525	0.01 in.
TE525WS	0.01 in.
TE525M	0.1 mm

Accuracy:

Rainfall Rate	TE525	TE525WS
Up to 1 in./hr	±1%	±1%
1 to 2 in./hr	+0, -3%	+0, -2.5%
2 to 3 in./hr	+0, -5%	+0, -3.5%

Rainfall Rate	TE525M
Up to 10 mm/hr	±1%
10 to 20 mm/hr	+0, -3%
20 to 30 mm/hr	+0, -5%

Signal Output:

Momentary switch closure activated by tipping bucket mechanism.
Switch closure is approximately 135 ms.

Calibration/Cleaning Frequency:

Sensor is factory calibrated and should not require field calibration.
Debris filters, funnel, and bucket reservoirs should be kept clean. Section 7 describes field calibration check and factory calibration.

Environmental Limits:

Temperature: 0° to +50°C
Humidity: 0 to 100%

Physical Data:

Diameter: 6.25 in. overall

Height

TE525 9.5 in.

TE525WS 12 in.

TE525M 12 in.

Weight: 2.5 pounds

Funnel: Gold anodized spun aluminum knife edge collector ring and funnel assembly.

Funnel Collector Diameter:

TE525 6.064 in.

TE525WS 8 in.

TE525M 9.664 in.

Resolution: 1 tip

Mounting: Side bracket with clamps for pole or mast mounting

Material: Aluminum

Cable: 2-conductor, shielded cable, length must be specified when ordering.

NOTE

The black outer jacket of the cable is Santoprene® rubber. This compound was chosen for its resistance to temperature extremes, moisture, and UV degradation. However, this jacket will support combustion in air. It is rated as slow burning when tested according to U.L. 94 H.B. and will pass FMVSS302. Local fire codes may preclude its use inside buildings.

3. Installation

3.1 Siting

The rain gauge should be mounted in a relatively level spot which is representative of the surrounding area. The lip of the funnel should be horizontal and at least 30 cm. above the ground. It should be high enough to be above the average snow depth. The ground surface around the rain gauge should be natural vegetation or gravel. It should not be paved.

The rain gauge should be placed away from objects that obstruct the wind. The distance should be 2 to 4 times the height of the obstruction.

When leveling, be sure that the funnel is properly seated in the body of the gauge and that:

- the orifice is level
- the body of the sensor is vertical (plumb).

3.2 Mounting

The CM300 Series mounting poles provide a stainless steel 1.5 IPS vertical pole for mounting the TE525 rain gauge. Pole length is 23", 47", or 56" for the CM300, CM305, and CM310 models respectively. The CM300 Series offers pedestal base options as well, as shown in Figure 3-2.

Use the enclosed hose clamps to mount the gauge as shown in Figure 3-1. The lip of the gauge should be at least 2 inches above the post or pole. Level the rain gauge after mounting it.

NOTE

Before final leveling, press either end of the bucket down against its stop to make sure the bucket is NOT hung up in the center.

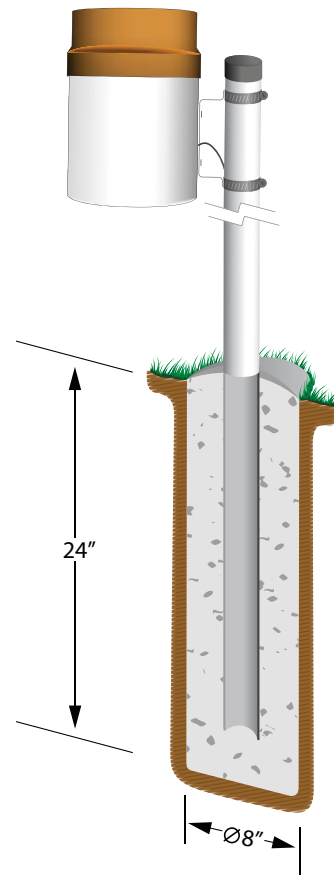

FIGURE 3-1. TE525 Tipping Bucket Rain Gauge

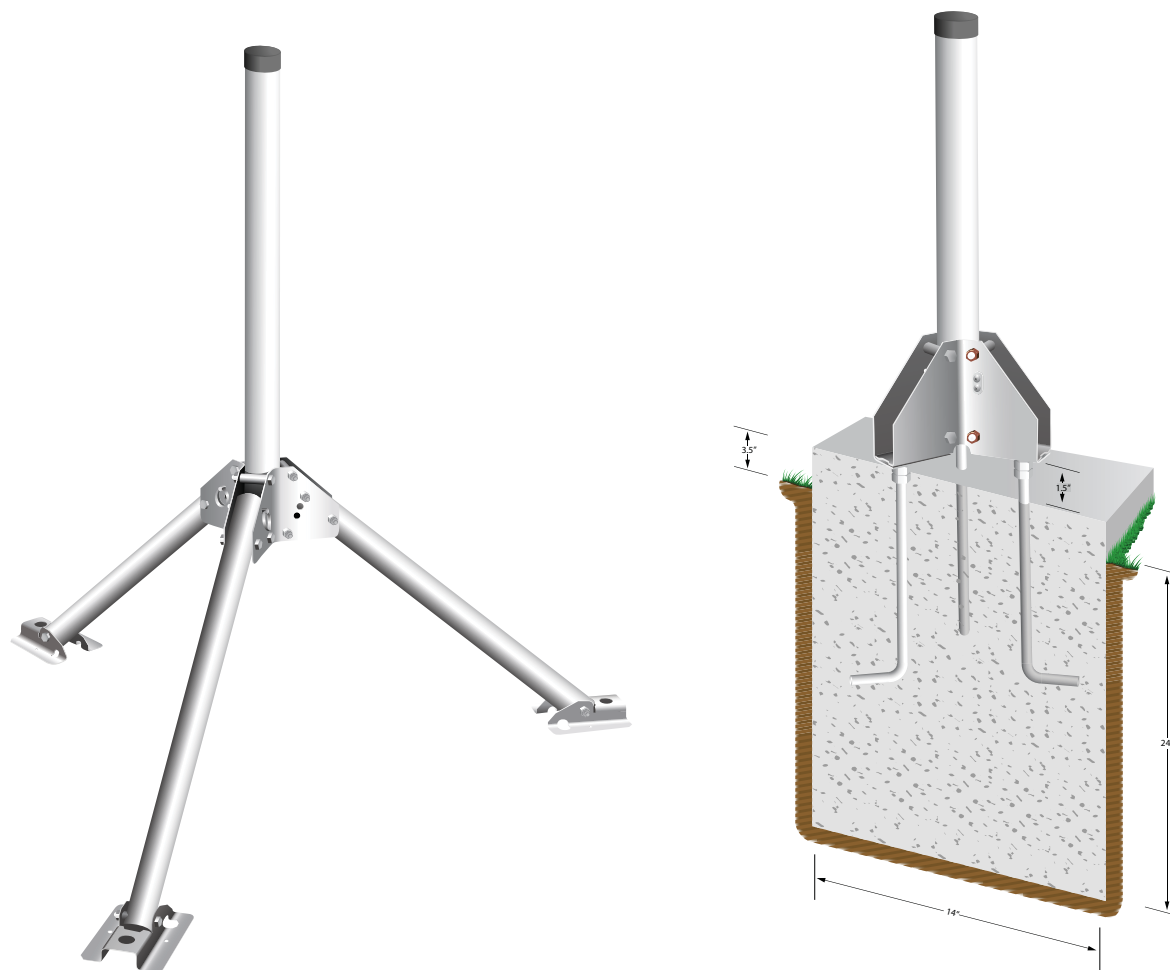

FIGURE 3-2. Pedestal Base Options

4. Wiring

Connections to Campbell Scientific dataloggers are given in Table 4-1. When Short Cut for Windows software is used to create the datalogger program, the sensor should be wired to the channels shown on the wiring diagram created by Short Cut.

TABLE 4-1. Wiring for Pulse Channel Input					
Color	Description	CR800 CR1000 CR3000 CR5000	CR510 CR500 CR10(X)	21X CR7 CR23X	CR200 Series
Black	Signal	Pulse Channel	Pulse Channel	Pulse Channel	P_SW
White	Signal Return	≐	G	≐	≐
Clear	Shield	≐	G	≐	≐

Dataloggers listed in Table 4-2 have the capability of counting switch closures on some of their control ports. When a control port is used, the return from the rain gauge switch must be connected to +5 volts on the datalogger.

Color	Description	CR800 CR1000 CR3000	CR500 CR510	CR10(X)	CR23X
Black	Signal	Control Port	C2/P3	Control Port	Control Port
White	Signal Return	5 V	5 V	5 V	5 V
Clear	Shield	≡	≡	G	≡

The CR10 does not support the use of control port inputs with the Pulse Count instruction; use Short Cut or see Example 8.5 in the CR10 operator's manual.

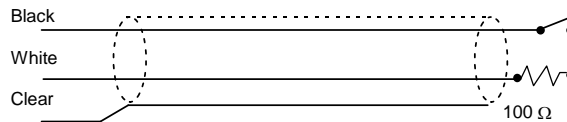

FIGURE 4-1. Rain Gauge Schematic

In a long cable there is appreciable capacitance between the lines. A built up charge could cause arcing when the switch closes, shortening switch life. A 100 ohm resistor is connected in series at the switch to prevent arcing by limiting the current (Figure 4-1). This resistor is installed on all rain gauges currently sold by Campbell Scientific.

5. Datalogger Programming

This section is for users who write their own programs. A datalogger program to measure this sensor can be created using Campbell Scientific's Short Cut Program Builder software. You do not need to read this section to use Short Cut.

The rain gauge is measured using the Pulse Count instruction with the switch closure configuration code. The multiplier used in the Pulse Count instruction determines the units in which rainfall is reported.

Rain Gauge	0.01 in	in	0.1 mm	mm
TE525	1.0	0.01	2.54	0.254
TE525WS	1.0	0.01	2.54	0.254
TE525M	0.394	0.00394	1.0	0.1
TE525 or TE525M w/8" funnel	0.57456	0.0057	1.459	0.1459

The volume of water required to cause a tip in the TE525 and the TE525M is the same. The difference in calibration is strictly due to funnel size. If the CS705 Snowfall Adapter or other eight inch funnel is installed on these gauges, use a multiplier from the last row in Table 5-1. (The CS705 will not install directly on the TE525M, the CS705 should be used with the TE525WS).

5.1 Example Programs

The following example program uses a pulse channel to read the output from the rain gauge and will work with the CR500, CR510, CR10(X), 21X or CR23X. The CR7 is similar but has an additional parameter in the Pulse Count instruction to specify the slot that the Pulse Card is in.

5.2 CR1000 Example Program

```
'CR1000
TE525/TE525WS & TE525M sample program
Public Rain_mm
Units Rain_mm=mm
DataTable(Rain,True,-1)
    DataInterval(0,60,Min,0)
    Totalize(1,Rain_mm,FP2,0)
EndTable

BeginProg
    Scan(1,Sec,1,0)
    'For TE525M Rain Gauge, use multiplier of 0.1 in PulseCount instruction
    PulseCount(Rain_mm,1,1,2,0,0.254,0)
    CallTable(Rain)
    NextScan
EndProg
```

5.3 CR10X Example Program

```
:{CR10X}
*Table 1 Program
01: 1.0000          Execution Interval (seconds)

1: Pulse (P3)
1: 1               Reps
2: 1               Pulse Channel 1
3: 2               Switch Closure, All Counts
4: 3               Loc [ Rain_mm ]
5: 0.254           Multiplier
6: 0               Offset

2: If time is (P92)
1: 0               Minutes (Seconds --) into a
2: 60              Interval (same units as above)
3: 10              Set Output Flag High (Flag 0)

3: Set Active Storage Area (P80)
```

```

1: 1          Final Storage Area 1
2: 101       Array ID

4: Real Time (P77)
1: 1220     Year,Day,Hour/Minute (midnight = 2400)

5: Totalize (P72)
1: 1        Reps
2: 3        Loc [ Rain_mm ]

*Table 2 Program
01: 0       Execution Interval (seconds)

*Table 3 Subroutines

End Program

```

5.4 CR200 Series Example Program

```

'CR200 Series

'Declare Variables and Units
Public Rain_mm

Units Rain_mm=mm

'Define Data Tables
DataTable(Rain,True,-1)
    DataInterval(0,60,Min)
    Totalize(1,Rain_mm,0)
EndTable

'Main Program
BeginProg
    Scan(1,Sec)
        'TE525/TE525WS Rain Gauge measurement Rain_mm:
        PulseCount(Rain_mm,P_SW,2,0,0.254,0)
        'Call Data Tables and Store Data
        CallTable(Rain)
    NextScan
EndProg

'For TE525M Rain Gauge, use multiplier of 0.1 in PulseCount instruction

```

5.5 Control Port Examples

These examples measure a TE525 rain gauge in mm. A different multiplier would be entered (Table 5-1) for other units.

5.5.1 CR1000 Example Program

```
'CR1000
'Declare Public Variables and Units
Public Rain_mm
Units Rain_mm=mm

DataTable (Rain,True,-1)
  DataInterval (0,60,Min,0)
  Totalize (1,Rain_mm,FP2,0)
EndTable

'Main Program
BeginProg
  Scan (1,Sec,1,0)
  'For TE525M Rain Gauge use multiplier of 0.1 in PulseCount Instruction.
  PulseCount (Rain_mm,1,18,2,0,.254,0)
  CallTable (Rain)
  NextScan
EndProg
```

5.5.2 C10X Example Program

```
:{CR10X}
;
*Table 1 Program
01: 1           Execution Interval (seconds)

1: Pulse (P3)
  1: 1           Reps
  2: 8           Control Port 8 (switch closure only) ;Black wire connect to C8
  3: 2           Switch Closure, All Counts
  4: 1           Loc [ Rain_mm ]
  5: .254        Multiplier
  6: 0           Offset

2: If time is (P92)
  1: 0           Minutes (Seconds --) into a
  2: 60          Interval (same units as above)
  3: 10          Set Output Flag High (Flag 0)

3: Set Active Storage Area (P80)
  1: 1           Final Storage Area 1
  2: 101         Array ID

4: Real Time (P77)
  1: 1220        Year,Day,Hour/Minute (midnight = 2400)

5: Totalize (P72)
  1: 1           Reps
  2: 1           Loc [ Rain_mm ]
```

*Table 2 Program 02: 0.0000	Execution Interval (seconds)
*Table 3 Subroutines	
End Program	

Output Instruction 72, Totalize, is used in the output section of the program to output the total rainfall over the output interval. This section should be executed every scan and not placed in a subroutine or conditional statement.

6. Troubleshooting

6.1 Precipitation

Symptom: No Precipitation

1. Check that the sensor is wired to the Pulse Channel specified by the pulse count instruction.
2. Verify that the Configuration Code (Switch Closure), and Multiplier and Offset parameters for the Pulse Count instruction are correct for the datalogger type.
3. Disconnect the sensor from the datalogger and use an ohm meter to do a continuity check of the switch. The resistance measured at the terminal block on the inside of the bucket between the black and white leads should vary from infinite (switch open) when the bucket is tipped, to less than an ohm when the bucket is balanced.
4. Ensure that the rubber band used to secure the tipping bucket during shipping has been removed.

7. Maintenance

The funnel and bucket mechanism must be kept clean. Routinely check for and remove any foreign material, dust, insects, etc. A calibration check is advised every 12 months. A 52260CS Rain Gauge Calibrator information sheet is attached to this manual.

Factory Calibration:

If factory calibration is required, contact Campbell Scientific to obtain an RMA (see Warranty and Assistance at front of manual).

Introduction:

The 52660CS Rain Gauge Calibrator offers a convenient way to determine rain gauge accuracy in the field. The 52260CS is a universal rain gauge calibrator and can be used with a wide variety of tipping bucket rain gauges. The 52260CS provides the flexibility of multiple flow rates at a constant head pressure in order to produce consistent results.

Equipment List:

1. Calibrated water bottle (1000 ml) with stand
2. Constant-head adapter
3. Nozzles for different flow rates
4. Graduated cylinder (250 ml)
5. Graduated syringe (35 ml)

Calibration Procedure:

1. Ensure that the rain gauge is properly leveled before calibration.
2. Connect rain gauge to datalogger or other electronic counter in accordance with the rain gauge literature. If a datalogger or counter is not available, the tips may be counted manually.
3. Select the appropriate nozzle for the desired rainfall rate (Refer to Table 1).
4. Fill the water bottle to the desired level using the graduated cylinder and syringe. Maximum accuracy can be obtained by using a laboratory balance to weigh the water (1ml = 1g). Attach adapter with nozzle to water bottle.
5. Position the bottle stand in the rain gauge funnel. Carefully invert the calibration bottle and place into stand. Water should flow from the nozzle. Be sure to position the bottle stand so that the water hits against the funnel sides and not directly into the funnel hole (Figure 1).
6. Allow water in bottle to flow through the rain gauge until empty. Record the bucket tips or rainfall amount. Refer to Table 2 for a list of common CSC rain gauges and their tipping bucket capacity. With the known values of water level used and the rain gauge bucket capacity, you can calculate an expected number of tips.
7. If the count is outside of the acceptable range, then the rain gauge calibrating screws will need to be equally adjusted to bring the rain gauge into specification. To increase the number of tips for a given volume of water the calibration screws will need to be adjusted upwards. To decrease the number of tips for a given volume of water the calibration screws will need to be adjusted downwards. The calibration procedure will need to be redone to confirm that the adjustment has brought the gauge into specification.

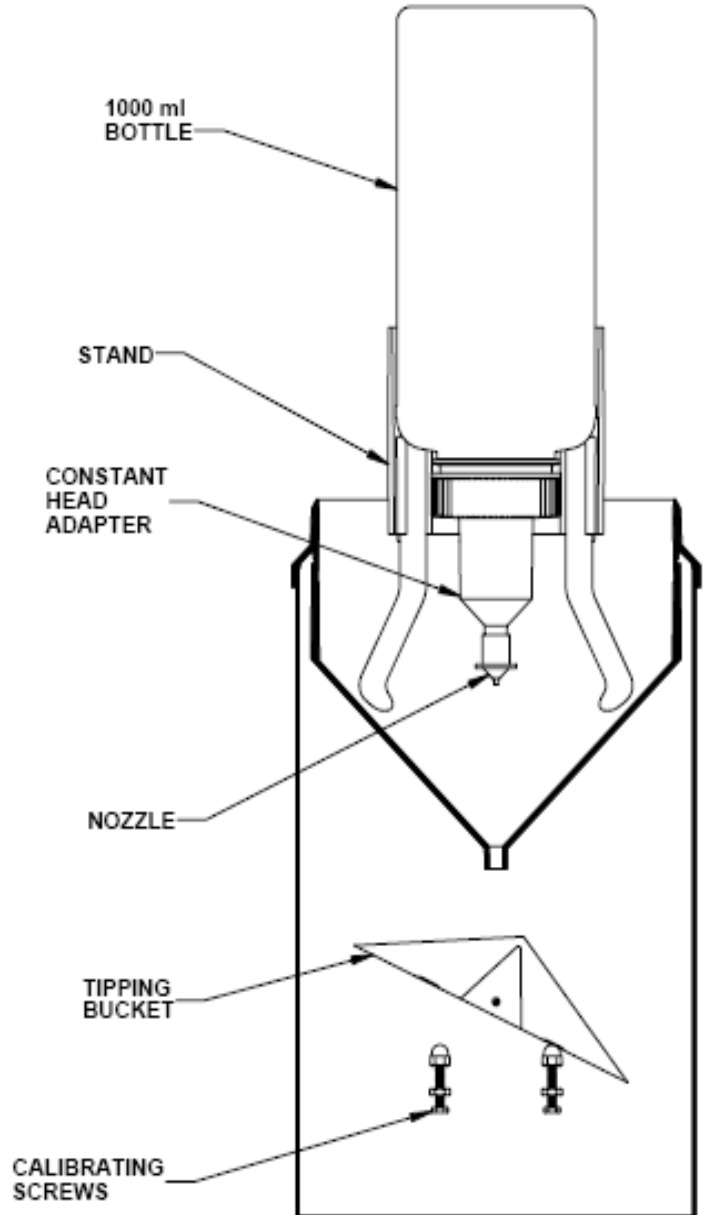

Figure 1: 52260CS and Rain Gauge Schematic

Orifice Diameter (in)	Approximate Flow Rate (ml/hr)*
0.032	1000
0.040	1500
0.045	2000

Table 1: Nozzle Types and Related Flow Rates

Model	Funnel I.D (in)	Funnel Area (in ²)	Rainfall/Tip	Funnel Volume	Bucket Capacity (ml)	Flow Rate Accuracy	Expected Tip Range for Listed Flow Rate Accuracy
TE525**	5.94	27.71	0.01 in	0.2771 in ³	4.54	-5% @ 1000 ml/hr	209 to 220 tips (1000ml)
TE525I** (not sold by CSC)	6.064	28.88	0.01 in	0.2888 in ³	4.73	-3% @ 1000 ml/hr	205 to 211 tips (1000ml)
TE525WS**	8.00	50.27	0.01 in	0.5027 in ³	8.25	-3.5% @ 1000 ml/hr	117 to 121 tips (1000ml)
TE525M	9.664	73.35	0.1 mm	4732 mm ³	4.73	-3% @ 1000 ml/hr	209 to 211 tips (1000ml)
						-3% @ 1500 ml/hr	308 to 317 tips (1500ml)
						-5% @ 2000 ml/hr	401 to 422tips (2000ml)
52202 (03)	6.30	31	0.1 mm	2000 mm ³	2.00	-2% @ 1000 ml/hr	490 to 500 tips (1000ml)
						-5% @1500 ml/hr	713 to 750 tips (1500ml)
						-10% @ 2000ml/hr	900 to 1000 tips (2000ml)

Table 2: Rain Gauge Funnel and Flow Specifications

It is possible to conduct these calibration checks using smaller volumes of water. Ideally this could be done as an initial test of a rain gauge's accuracy. Once the accuracy of the gauge is determined and any required calibration adjustments are made, a larger volume of water should be used to ensure the best performance of the gauge. Such initial tests of accuracy must be done at the slowest flow rates to provide the best accuracy possible.

As an example of an initial test for the 52202 rain gauge, if an individual were to use a water volume of 500 ml at a flow rate of 1000 ml/hr, the gauge should tip between 245 and 250 times in approximately 30 minutes.

Notes:

* Flow rates may vary due to conditions during calibration

** Accuracy at other flow rates is not known for sensor.

1. For best results the calibration test should use the largest volume of water that time will allow.
2. Multiple tests may be required.
3. Normal operational characteristics of tipping bucket rain gauges will produce larger errors at higher rainfall rates.