



SP Lite2 Silicon Pyranometer

FOR COST EFFECTIVE MEASUREMENT OF GLOBAL RADIATION

Compact and lightweight

Designed for use under all weather conditions

Used around the world in meteorology, hydrology and agriculture

Ideal for solar energy applications

INTRODUCTION

The effects of solar radiation are far reaching and it drives the dynamic processes on the Earth's surface and in the atmosphere. The total (global) irradiance on a plane surface is measured by a pyranometer. Kipp & Zonen has been manufacturing pyranometers for over 75 years and we produce models at all price and performance points, up to the very best available. However, some applications require a small and relatively low cost sensor with a fast response time, whilst retaining Kipp & Zonen quality. Therefore we developed the SP Lite2 Silicon Pyranometer.

SP Lite2 can be used under all weather conditions and is designed for a long operating life with simple maintenance. The sensor receives solar energy from the entire hemisphere in its view and produces a small voltage output that can be converted into the irradiance in Watts per square meter (W/m^2).

SP Lite2 is installed around the world for meteorology, hydrology, agriculture and building automation; where reliable measurement at relatively low cost is required, and

the performance of a broadband thermopile pyranometer is not needed.

SP Lite2 is particularly suited to monitoring the efficiency of photovoltaic solar energy systems, where the spectral response is similar to that of PV cells. Solar radiation is also a key input to decision making on activities such as product quality control, determination of optimum location and predicting the system output under various sky conditions.

SP Lite2 is a simple pyranometer for routine measurements of solar radiation. It has a conical Teflon™ diffuser that provides excellent directional (cosine) response, causes rain to run off and is easy to clean. Although the spectral range is limited by the photo-diode detector, the performance of the SP Lite2 compares favorably to ISO 9060 Second Class thermopile pyranometers under clear and unobstructed natural daylight conditions.

The mounting flange incorporates a bubble level and adjustment screws, for easy leveling. A threaded hole takes the accessory screw-in mounting rod for fitting to masts and poles. Two SP Lite2 instruments can easily be bolted back-to-back, and fitted with the mounting rod, to make a simple albedometer. The standard cable length is 5 m, with an option of 15 m. SP Lite2 is ideal for use with the METEON handheld display and data logger for field test use.

Specifications

Response time (95 %)	< 1 s
Non-stability (change/year)	< 2 %
Non-linearity (0 to 1000 W/m ²)	< 1 %
Directional error (at 80 ° with 1000 W/m ² beam)	<50 W/m ²
Temperature dependence(-30 to +70 °C)	- 0.15 %/°C

Other specifications

Sensitivity	60 to 100 µV/W/m ²
Impedance	50 Ω
Operating temperature	-30 °C to +70 °C
Spectral range (50 % points)	400 to 1100 nm
Typical signal output for atmospheric applications	0 to 100 mV
Maximum irradiance	2000 W/m ²
Detector	Silicon photo-diode

SP Lite2 has a standard captive cable of 5 m length. Optional cable length 15 m.

Spectral response

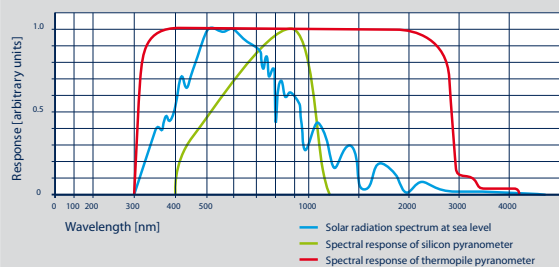

Directional response

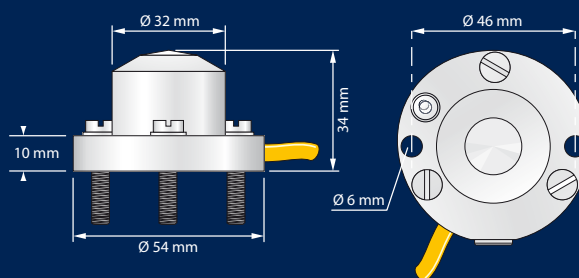
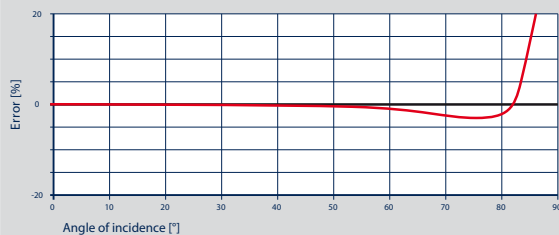

Albedo set-up

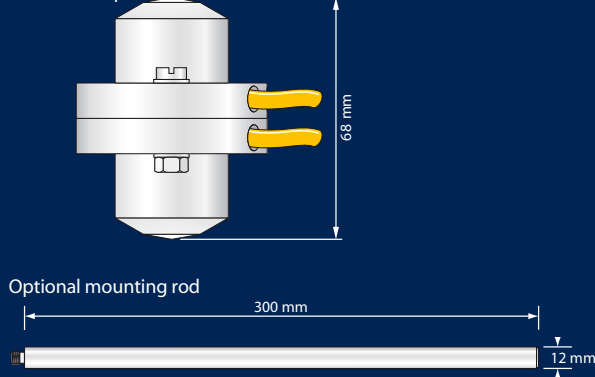

Go to www.kippzonen.com for your local distributor

HEAD OFFICE

Kipp & Zonen B.V.
Delftechpark 36, 2628 XH Delft
P.O. Box 507, 2600 AM Delft
The Netherlands
T: +31 (0) 15 2755 210
F: +31 (0) 15 2620 351
info@kippzonen.com

Kipp & Zonen B.V. reserve the right to alter specifications of the equipment described in this documentation without prior notice



CAMPBELL SCIENTIFIC
CANADA CORP
11564 - 149 street - edmonton - alberta - T5M 1W7
tel 780.454.2505 fax 780.454.2655
www.campbellsci.ca

4414396-1001