

INSTRUCTION MANUAL



SDM-CVO4 4-Channel Current/Voltage Output Module

Revision: 7/11



Copyright © 2001-2011
Campbell Scientific, Inc.

WARRANTY AND ASSISTANCE

This equipment is warranted by CAMPBELL SCIENTIFIC (CANADA) CORP. ("CSC") to be free from defects in materials and workmanship under normal use and service for **twelve (12) months** from date of shipment unless specified otherwise. ***** **Batteries are not warranted.** ***** CSC's obligation under this warranty is limited to repairing or replacing (at CSC's option) defective products. The customer shall assume all costs of removing, reinstalling, and shipping defective products to CSC. CSC will return such products by surface carrier prepaid. This warranty shall not apply to any CSC products which have been subjected to modification, misuse, neglect, accidents of nature, or shipping damage. This warranty is in lieu of all other warranties, expressed or implied, including warranties of merchantability or fitness for a particular purpose. CSC is not liable for special, indirect, incidental, or consequential damages.

Products may not be returned without prior authorization. To obtain a Return Merchandise Authorization (RMA), contact CAMPBELL SCIENTIFIC (CANADA) CORP., at (780) 454-2505. An RMA number will be issued in order to facilitate Repair Personnel in identifying an instrument upon arrival. Please write this number clearly on the outside of the shipping container. Include description of symptoms and all pertinent details.

CAMPBELL SCIENTIFIC (CANADA) CORP. does not accept collect calls.

Non-warranty products returned for repair should be accompanied by a purchase order to cover repair costs.



CAMPBELL SCIENTIFIC
C A N A D A C O R P .

11564 - 149 street - edmonton - alberta - T5M 1W7
tel 780.454.2505 fax 780.454.2655

www.campbellsci.ca

PLEASE READ FIRST

About this manual

Please note that this manual was originally produced by Campbell Scientific Inc. (CSI) primarily for the US market. Some spellings, weights and measures may reflect this origin.

Some useful conversion factors:

Area:	1 in ² (square inch) = 645 mm ²
Length:	1 in. (inch) = 25.4 mm 1 ft (foot) = 304.8 mm 1 yard = 0.914 m 1 mile = 1.609 km
Mass:	1 oz. (ounce) = 28.35 g 1 lb (pound weight) = 0.454 kg
Pressure:	1 psi (lb/in ²) = 68.95 mb
Volume:	1 US gallon = 3.785 litres

In addition, part ordering numbers may vary. For example, the CABLE5CBL is a CSI part number and known as a FIN5COND at Campbell Scientific Canada (CSC). CSC Technical Support will be pleased to assist with any questions.

SDM-CVO4 Table of Contents

PDF viewers note: These page numbers refer to the printed version of this document. Use the Adobe Acrobat® bookmarks tab for links to specific sections.

1. Introduction	1
2. Specifications	2
2.1 General Specifications	2
2.2 Output Specifications.....	3
2.3 Isolation Specifications.....	3
3. Power Considerations	4
4. Installation	4
4.1 Connection to a Datalogger	4
4.2 Output Device Connections	6
4.2.1 Voltage Output Mode	6
4.2.2 Current Output Mode.....	6
4.2.3 Shield and Ground Connections	7
4.2.4 Output Terminal Connectors.....	8
4.3 Output Mode Setting	8
4.4 SDM Address Setting	9
4.5 Safety Considerations	10
5. General Principles of Use	12
5.1 Voltage or Current Signaling.....	12
5.2 Providing Excitation Supplies to Sensors.....	12
6. Datalogger Programming	13
6.1 CRBasic SDMCVO4 Instruction.....	14
6.2 SDMCVO4 Instruction Example.....	15
6.3 SDMSpeed Instruction	16
6.4 Edlog Instruction 103	16
6.5 Edlog Program Examples	18
6.5.1 Voltage and 0-20 mA Current Output Modes.....	18
6.5.2 Restricted Range Current Output Modes (4-20 mA)	20
6.5.3 Providing Isolated Power Supplies to Sensors.....	22

Figures

1. SDM-CVO4.....	1
4-1. Use of the Spring-Loaded Terminal Blocks (Top Position).....	5
4-2. Use of the Spring-Loaded Terminal Blocks (Front Position).....	5
4-3. Location of Jumpers on Circuit Board	9
4-4. Address Selection Switch.....	10

Tables

- 4-1. Datalogger to SDM-CVO4 Connections 4
- 4-2. Switch Position and Addresses..... 10
- 6-1. Description of SDM Speed..... 16
- 6-2. Description of Instruction 103 17

SDM-CVO4 4-Channel Current/Voltage Output Module

The SDM-CVO4 is a synchronously addressed datalogger peripheral designed to allow the datalogger to output variable voltage or current signals under program control.



FIGURE 1. SDM-CVO4 (shown without mounting brackets)

1. Introduction

The SDM-CVO4 expands the analog output capability of Campbell Scientific dataloggers. Each output can be set to 0-10V or 0-20mA by the datalogger. The output can be scaled and limited to 4-20mA by the datalogger program if required by the application.

Typical applications will include driving remote 'current-loop' display units, re-transmitting measured values to industrial control systems which have current or high voltage inputs, sending control signals to valve controllers and providing excitation voltages or currents to external sensors.

Each output is isolated both from the datalogger and the other channels on the CVO4, thereby avoiding ground loop problems that might otherwise occur.

In the current mode the output can either act as a 2-wire current controller, where the loop is powered from a remote voltage source, or it can be used to generate a 0-20 mA current source using a voltage output derived from its own power supply.

The SDM-CVO4 is a synchronously addressed datalogger peripheral. The datalogger's SDM ports are used to address the SDM-CVO4 and send out data that defines the desired voltage/current output of each of the four channels. The output levels are set by four values stored in variables or successive input locations in the datalogger. A total of up to sixteen SDM-CVO4s or other SDM peripherals may be connected and addressed from the same three 'SDM' ports.

NOTE

For the CR7, CR10(X), CR23X, and 21X dataloggers Instruction 103 is used to control the SDM-CVO4. This was introduced in August 1988 for controlling SDM-AO4 functions. (The SDM-AO4 is an older voltage-output-only peripheral.) Dataloggers purchased before this date may use a different instruction.

The SDMCVO4 instruction is used with the CR800, CR850, CR1000, CR3000, and CR5000.

2. Specifications

2.1 General Specifications

Compatible dataloggers: CR800, CR850, CR1000, CR3000, CR5000, and CR7. Also compatible with many retired dataloggers such as the CR10, 21X, and CR23X.

Operating voltage: 12 VDC nominal (8 V to 16 V)

Current drain at 12V DC: Typical active quiescent current 27 or 54 mA, depending on operating mode (no load on output ports). To estimate the total current, add the quiescent current to the sum of all output currents multiplied by 1.5.

E.g. if each port is at 10 mA output, the total = $54 + (1.5 * 4 * 10) = 114$ mA. The device can be shut down to <0.5 mA with all outputs off.

Maximum Total SDM cable length: 600 ft (182 m) for the CR7; 20 ft (6 m) for other dataloggers if the SDMSpeed Instruction is not used. For our CR800, CR850, CR1000, CR3000, and CR5000 dataloggers, cable lengths longer than 20 ft may be acceptable if the SDMSpeed instruction is used.

Operating temperature: -25°C to +50°C standard (-40 to 80°C optional)

Size: 176 mm wide x 111 mm high x 24 mm deep.
234 mm wide x 111 mm high x 24 mm deep when fitted with brackets for mounting in enclosure, etc. Mounting brackets have two holes at 203.2 mm (8") spacing for screw fixings.

Weight:	370 g
EMC Status:	Complies with EN55022-1:1998 and EN50082-1:1998

2.2 Output Specifications

Voltage Mode:	<p>Range: 0 – 10,000 mV Resolution: 2.5 mV Maximum Output Current: 30 mA per channel. Minimum load current: 5 μA if output < 200 mV. Accuracy (+23°C): \pm0.02% of set voltage + (\pm 2.5 mV). Accuracy (-25 to +50°C): \pm0.13% of set voltage + (\pm 2.5 mV).</p>
Current Mode:	<p>Range: 0 – 20 mA Resolution: 5 μA Minimum output current (leakage): 5 μA at +50°C. Accuracy (+23°C): \pm0.02% of full scale range + (\pm 5 μA). Typical Accuracy (-25° to +50°C): \pm0.1% of full scale range + (\pm 5 μA). Worst Case Accuracy (-25° to +50°C): \pm0.15% of full scale range + (\pm 5 μA). Minimum voltage drop across the internal current regulating circuit: 2.5 V at 20 mA current flow. Maximum voltage into I_d relative to channel ground: 20 VDC. When in current mode, the V_o terminal outputs an unregulated voltage source at 15 V nominal (\pm10%), 30 mA maximum load. Please contact Campbell Scientific for the accuracy specification on extended temperature tested units.</p>

2.3 Isolation Specifications

Design criteria:	<p>The unit has an internal isolation barrier and components rated to provide signal isolation for transients up to 1500 VAC (RMS), 2500 VDC nominal. The isolation is between any output and the SDM-CVO4 ground connection and between individual output channels.</p> <p>Protection components are built-in, which will break down in a controlled fashion at voltages close to this limit (see section 4.5, Safety Issues).</p>
Tested isolation:	<p>Each channel of each unit is tested for isolation resistance at 500 VDC. Pass level > 10 MΩ.</p>

Maximum recommended continuous operating voltage: 240 VAC RMS differential between an output and datalogger ground - providing all issues relating to local regulations for safe installation and operation are followed (see section 4.5, safety issues).

3. Power Considerations

The SDM-CVO4 power requirements are large compared to most Campbell Scientific products, especially when driving significant loads. Care must be taken to ensure that the power supply can cope with this higher demand.

Alkaline batteries are *not* recommended for long term applications.

The SDM-CVO4 has two internal power supplies, one for channels 1 and 2 and one for channels 3 and 4. It will only turn on the power supply for channels 3 and 4 if sent an instruction that sets the output of those channels. If channels 3 and 4 are not used the power consumption is approximately 20 mA lower than when all outputs are used.

Where supported by the datalogger, and when the application allows it, the SDM-CVO4 can be shut down to reduce its consumption to less than 0.5 mA. In this state all outputs are switched off.

4. Installation

Prior to installing the device you need to set the output mode (current or voltage) of each channel by positioning internal jumpers (see section 4.3). You also need to set the SDM address of the module (see section 4.4) and additionally consider any safety issues specific to the installation (see section 4.5).

4.1 Connection to a Datalogger

For datalogger connections, see Table 4-1, below.

Connection Order	SDM-CVO4	Datalogger	Function
First	12 V	12 V on datalogger or external supply	Power
Second	\perp or G	\perp or G	Common Ground
	C1	SDM-C1 (CR3000, CR5000) or C1 (other dataloggers)	Data
	C2	SDM-C2 (CR3000, CR5000) or C2 (other dataloggers)	Clock
	C3	SDM-C3 (CR3000, CR5000) or C3 (other dataloggers)	Enable

Multiple SDM-CVO4s may be wired in parallel by connecting the SDM and power connections from one SDM-CVO4 to the next.

NOTE

If the total cable length connecting SDM-CVO4s to SDM-CVO4s, other SDMs and the datalogger exceeds 6 m, the SDM baud rate may need to be reduced to ensure reliable operation. Please contact Campbell Scientific for more information.

The transient protection of the SDM-CVO4 relies on a low resistance path to earth. Ensure that the ground return wire has as low a resistance as possible. An additional G terminal is provided which can be connected directly to the enclosure earth ground terminal to ensure this. Make sure the ground wire from the SDM-CVO4 to the datalogger goes to its G terminal and not the AG terminal.

The SDM-CVO4 uses spring-loaded terminal blocks for the connections to the datalogger which provide quick, vibration resistant, connections. To attach wires, insert a small screwdriver into either the top or front slot, as appropriate, and push to open the terminal spring. Strip any insulation from the wire to give 7 to 9 mm bare wire. Push the wire into the opening, and, while holding it in position, withdraw the screwdriver to release the spring. The wire will now be firmly held in place. See Figures 4-1 and 4-2, below.



FIGURE 4-1. Use of the Spring-Loaded Terminal Blocks (Top Position)

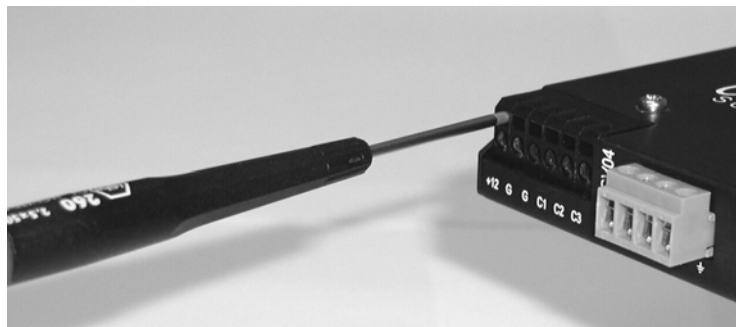

FIGURE 4-2. Use of the Spring-Loaded Terminal Blocks (Front Position)

You cannot reliably insert more than one solid-core wire into one terminal connector unless the wires are soldered or clamped together. When inserting more than one stranded wire, twist the bare ends together before insertion.

4.2 Output Device Connections

For each output channel there are four terminals which are labeled V_o , I_d plus there are two ground (\perp) connections per channel. The two ground terminals are internally connected; two are provided for convenience.

4.2.1 Voltage Output Mode

The V_o terminal is the output for either the preset voltage signal, when the channel is set to operate in voltage mode or an unregulated 15 VDC power source in current mode.

In voltage mode the connection to a remote device is a simple two wire connection:

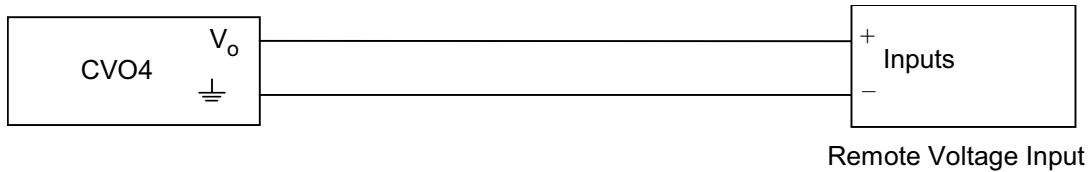

4.2.2 Current Output Mode

The I_d terminal acts as the input for the current that is to be controlled. In current output mode you arrange to sink current into the terminal with a positive current flowing relative to the ground terminals. (In voltage output mode this terminal has no function.)

There are several different possible connections in current mode. As each channel is isolated and floating, the method of connection to a remote device is flexible. There are two different ways of powering the loop current.

- a) The remote device powers the loop, where, depending on the ground referencing requirements of that device, the connection can be as shown in the diagrams below:

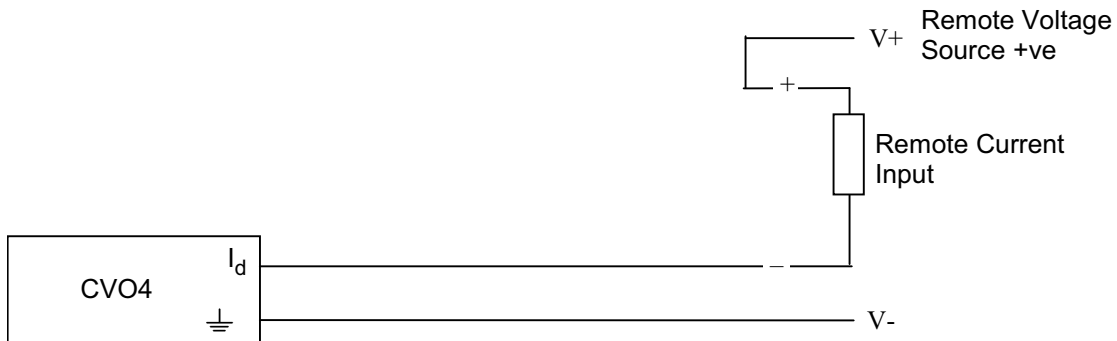

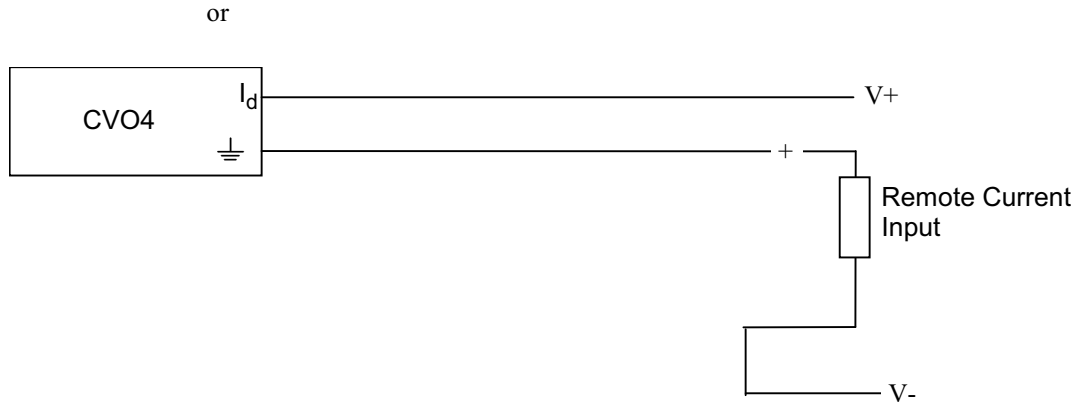

- b) The SDM-CVO4 provides the voltage source to drive the loop. In this case the only real option is:

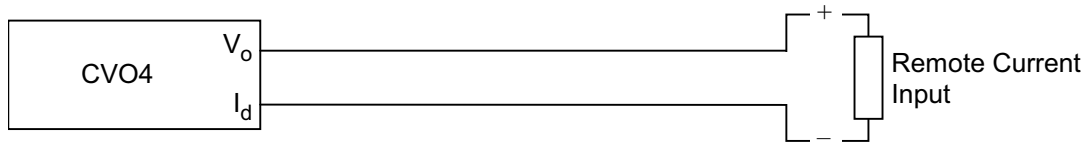

In both cases you need to consider whether the voltage supply is high enough to allow the maximum current to flow (20 mA) through all of the series resistances in the current loop. When considering this factor you need to allow for a minimum 2.5 V drop between the I_d and ⏏ terminal of the SDM-CVO4. You need to add this value to the estimated drop of 20 mA flowing through the total resistance of the cable in the 'loop' plus any voltage drop in the remote device (normally the voltage drop across a fixed sense resistor).

As a simple example, consider the situation where the SDM-CVO4 is powering the loop (as in (b) above), then the supply voltage output from V_o is 13.5 (absolute minimum). If the remote device has a 250 ohms sense resistor this will drop 5V at 20mA (using Ohm's law), which in addition to the SDM-CVO4's 2.5 V drop in the loop means the maximum allowable voltage drop in the cable of the loop should be $13.5 - 5.0 - 2.5 = 6.0$ V. At 20 mA current flow, the loop could therefore have a maximum resistance of 300 ohms. Standard 24 AWG (7/0.2 mm) cable has a typical resistance of 85 ohms per 1000 m. Allowing double this resistance to form a loop (there and back), will mean the total cable length could be as long as 1700 m before the supply voltage started to limit the current flowing.

4.2.3 Shield and Ground Connections

It is generally advisable to use shielded (screened) cable when connecting the output to any remote system to reduce the chances of noise pickup. The shield will only be effective if it is connected to a good ground reference point.

As a result of the isolation barrier in the SDM-CVO4, the ground terminals associated with the output connector of each channel cannot be considered as good ground reference points. Therefore it is advisable to make the connection of the screen to a good ground point at the remote system rather than the

SDM-CVO4. Do not connect the screen at both ends of the cable as this may result in a ground loop being formed.

The output circuitry of the SDM-CVO4 includes protective components to minimize the chances of damage that can be caused by transients which can be induced in the signal cable. The protection clamps the transient voltages to non-damaging levels relative to the ground terminals on each output channel.

If the voltage of that ground point exceeds the datalogger ground potential by more than approximately 2500 VDC, a secondary level protector will break down to provide a path for energy to discharge to the datalogger ground. The likelihood of secondary breakdown can be avoided, if required (perhaps for safety reasons), by connecting a wire to the output ground terminals of the SDM-CVO4 to provide a low impedance path to ground. In doing this, though, there is a risk that you will nullify the effects of the isolation barrier, e.g. if the ground you connect to is the same ground to which the datalogger is connected.

You need to carefully study the ground connections of the entire system when connecting a grounding wire to the output ground terminal, both to avoid creating a ground loop/referencing problem and also possibly causing a safety issue.

4.2.4 Output Terminal Connectors

The output connections use normal, 4-way, screw terminal fixings. These can be unplugged for ease of wiring, if required.

4.3 Output Mode Setting

An internal jumper sets the output mode for each channel of the SDM-CVO4. The output mode can either be voltage or current mode, as described above. To change the mode setting, the case must be opened. To do this first disconnect the device from any source or power, disconnect the output connections (you can unplug the connectors) and then remove the four larger screws from the face of the case which has the product name written. Lay the unit on a flat surface and then, after taking anti-static precautions, lift off the top half of the case to expose the circuit board.

Then refer to Figure 4-3 below to identify the block of jumpers that control the output mode. To operate in current mode, the jumper relevant to the channel concerned must be installed between the two jumper pins, as shown. If operating in voltage mode, the jumper should not bridge any two pins, but may be stored, if required, by fitting it to just one of the pins, leaving the other half unconnected.

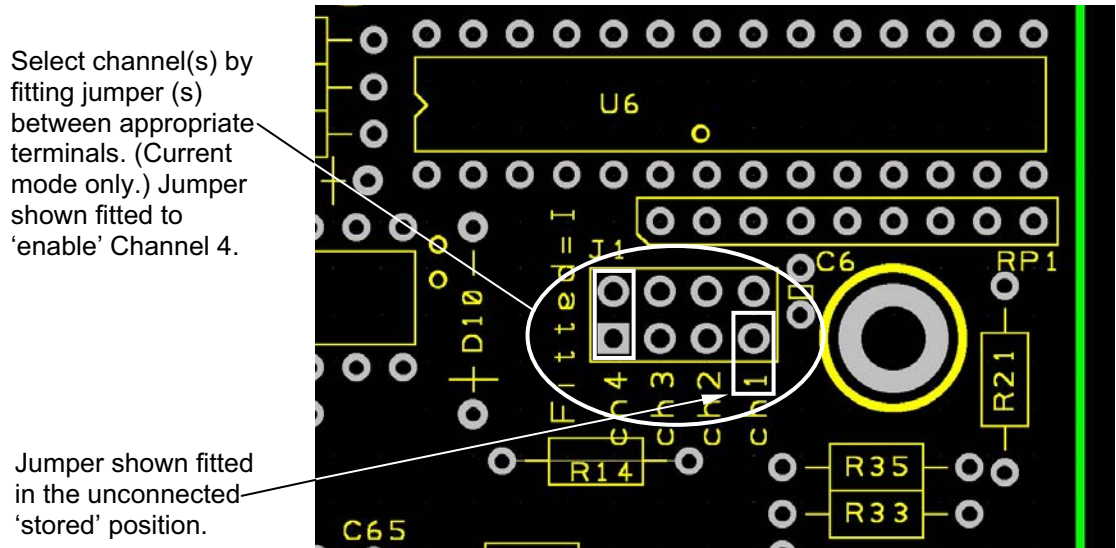

FIGURE 4-3. Location of Jumpers on Circuit Board

CAUTION

Do not store the jumpers between any other pins in the block as this may switch the module into a factory calibration mode, which may result in abnormal operation and change of output accuracy.

The jumper settings can be overridden by the datalogger program, if required, using special commands. Please contact Campbell Scientific for details.

4.4 SDM Address Setting

Each SDM-CVO4 can have 1 of 16 addresses. The factory-set address is 00. Table 4-2 shows switch position and the corresponding address. Figure 4-4 shows the position of the switch on the right-hand end of the casing. Note that you will have to remove the right-hand mounting bracket to gain access to this switch.

Switch Setting	Base 4 Address
0	00
1	01
2	02
3	03
4	10
5	11
6	12
7	13
8	20
9	21
A	22
B	23
C	30
D	31
E	32
F	33

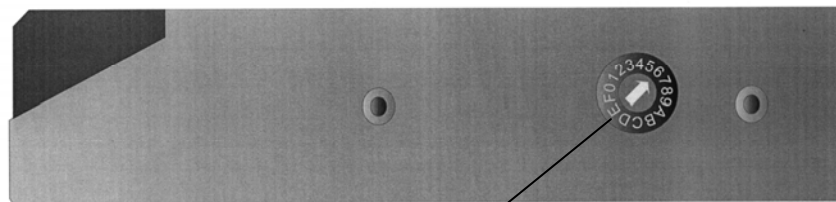

Use a screwdriver to select address

FIGURE 4-4. Address Selection Switch

The address switch has a hexadecimal setting position (0..F). Most datalogger instructions require you to enter the address as a base 4 number. Please see your datalogger manual for more details of the convention required.

4.5 Safety Considerations

Where the potential voltage difference between the datalogger and the SDM-CVO4 outputs is considered to be non-hazardous (less than 50 V) then the unit can be used as any other peripheral without undue concerns as to the risks to safety of the user.

As with the datalogger, it is essential to ensure that the device has a good connection to an earth grounding point to allow the safe discharge of any transient voltages and also ensure proper screening of the device. The SDM-CVO4 has two G terminals on the black connector which are used for connections to the datalogger. One of these can be used to connect the device directly to the earth ground point of the enclosure to ensure the lowest resistance path to ground.

Where the SDM-CVO4 is going to be used in applications where the potential difference between the datalogger and the output terminals exceeds 50 V RMS AC, 74 VDC then careful consideration has to be taken to ensure safe operation and compliance with local safety regulations. For such applications Campbell Scientific does not supply the device as a stand-alone device which will meet all safety requirements. The SDM-CVO4 is supplied as a component for the user to install in a system that is, itself, designed to comply with such regulations. The following guidance is given to help users meet the requirements of such regulations.

The SDM-CVO4 is designed such that the internal safety barrier meets the requirements of BS EN 61010-1 (similar to IEC 950). However, the method of wire connection and earthing facilities prevents the unit being claimed as compliant with such standards, when supplied as a stand-alone unit.

To meet the safety requirements of most countries, wires carrying hazardous voltages, terminated in screw terminals must be housed in an enclosure requiring a tool to open it, and the enclosure must have international symbols on the outside warning of high voltages. An additional warning label, in the local language, may be required stating that the source of hazardous voltage must be turned off before the enclosure is opened.

The exact nature of the enclosure is covered by the standards, but an enclosure designed to house electrical equipment will usually meet the requirements. Campbell Scientific's ENC 12/14 or 16/18 enclosures meet these requirements if fitted with a padlock and with the correct labels on the door.

It is also necessary to ensure that metal parts on the outside of the enclosure that might come in contact with active high voltage circuits are connected to a safety ground. The ground lug of Campbell Scientific enclosures is the main issue for the above enclosures, but this would, in any case, normally be the point of contact to a good ground point.

Cables that connect to the output of the SDM-CVO4 should have adequate strain relief at the point of exit from the enclosure, and the cable and any connectors used should be rated to a high enough voltage and assembled in a safe fashion.

If possible, the external device which is operating at a high voltage relative to ground should be configured with an earth leakage breaker system to disconnect it from the voltage source in the event of a breakdown of the insulation in the system causing a leak to ground.

With a system made to the above requirements the maximum recommended continuous operating voltage between the datalogger and input is 240 VAC. This value is derived from the voltage rating of the terminal blocks used and an internal suppression capacitor (see below).

The unit is designed to withstand a transient flash test of 1500 V RMS AC, for two seconds. However, you need to be aware of some aspects of the design which can influence the results of such a test if made.

- a) To help suppress emissions of electromagnetic interference the isolation barrier is bridged by a 1nF, class 'Y' safety capacitor. This

is rated to withstand a 2700V, 2 second flash test, but will fail if exposed to voltages in excess of 240 V RMS for long periods.

- b) To provide protection from transients and static for this capacitor and the opto-isolation component that bridges the barrier, there is a spark gap across the barrier that has a 2500 VDC nominal breakdown voltage. If this device is at the low end of its tolerance band ($\pm 10\%$), combined with the normal tolerance of flash test devices, then the spark gap could fire during a 1500 VAC flash test, which may cause an indication of failure. Testing at a slightly lower voltage will confirm whether there is a true fault or not.

If you have any doubts about the safety of your installation please first seek advice from your local safety advisor and then Campbell Scientific if you require further technical details.

CAUTION

To ensure safe and correct operation, the SDM-CVO4 *must* be installed where there is no risk of water ingress or condensation.

5. General Principles of Use

5.1 Voltage or Current Signaling

Where the SDM-CVO4 is being used to retransmit measured values from sensors to remote displays or measurement systems, the datalogger program would normally follow the process of taking measurements and writing the measured values into input locations using the same principles as given in the manuals for those sensors.

The measured values would then be scaled using the processing instructions of the datalogger, using either Instructions 37 and 34 or Instruction 53 (if available in your datalogger). Prior to scaling, or during the scaling calculations, the values relating to the four channels of the SDM-CVO4 will normally be written into four new sequential input locations, both to match the required inputs for Instruction 103 and also to preserve the original measurement values for other purposes.

Instruction 103 would then be executed at the same rate as the measurements have been made, to transmit the settings to the SDM-CVO4 and cause the outputs to be updated at the same rate. As the required output levels are held in a digital form in the SDM-CVO4, there is little advantage in sending data more frequently – the only benefit being that it would recover more quickly in the event of a loss of power.

5.2 Providing Excitation Supplies to Sensors

As mentioned in the introduction to this manual, one application for this device is to provide an excitation to a sensor or sensors that are to be measured by the datalogger. This may be considered where a sensor requires a precise voltage or current excitation which cannot be provided by the datalogger itself, or perhaps where exciting the sensor from the datalogger or its power supply would cause a common-mode measurement problem. An example of the latter

problem is where the sensor outputs are not within the common-mode voltage that the datalogger will accept (± 2.5 V for the CR10X).

Careful consideration should be made before using an SDM-CVO4 for such a function. Not only is it a relatively expensive method, but it can also result in a less accurate method of sensor measurement (compared to when the datalogger excites the sensors directly) if the precision of the output is critical to the sensor accuracy.

The reason for this is that direct datalogger excitation is a ratiometric measurement whereby any drift in the excitation output of the datalogger is compensated for. With the SDM-CVO4 as an excitation source, any drift in its output accuracy, or of the logger measurement accuracy, can result in a combination of those errors. It is worth investigating, therefore, the exact requirements of the sensors you wish to use. For instance, on closer inspection of the specification of many pressure sensors you will often find the recommendation of 10V excitation, but in reality many will accept a lower voltage. If new sensors are to be bought for a specific project, it can be worth checking if versions of sensors are available that will accept a low voltage excitation.

There are, however, some sensors that have active components or that have large common mode output voltages that require an isolated and/or precise high voltage supply within the current output capability of the SDM-CVO4. In this context the SDM-CVO4 can be used to provide an isolated supply which can be regulated in the range of 0-10,000 mV, a regulated current (0-20 mA) or an unregulated 15 V (nominal) supply (by setting current output mode and using the V_o terminal).

In these applications, if all channels of the SDM-CVO4 are being used for exciting sensors, you can use the standby mode between measurements to save power. To do this you would send a command (instruction 103 with zero reps - see below) to the SDM-CVO4 to shut it down after making the measurements. When using this mode you need to allow at least 100ms after turning the SDM-CVO4 on again (by using instruction 103 with a non-zero number of reps) for the outputs to stabilize, before starting your measurement sequence.

It is possible that you can power more than one sensor from each output of the SDM-CVO4, either by parallel connection in voltage output mode or serial connection in current output mode. Make sure, however, that you do not try to take more current than available in voltage mode. Additionally you also need to check that all outputs from the sensors powered by one channel do not have a spread which exceeds the common mode range of the datalogger inputs.

6. Datalogger Programming

Our CR800, CR850, CR1000, CR3000, and CR5000 use the SDMCVO4 instruction in CRBasic. Our CR7, CR10(X), 21X, and CR23X dataloggers use Edlog Instruction 103. Both CRBasic and Edlog are provided in PC400, LoggerNet, and RTDAQ software.

6.1 CRBasic SDMCVO4 Instruction

This instruction is used to control the SDM-CVO4 four channel current/voltage output device.

Syntax

SDMCVO4 (CVO4Source, CVO4Reps, SDMAddress, CVO4Mode)

Remarks

This instruction controls the SDM-CVO4, which outputs a voltage or a current. Internal jumpers are used to set the mode for the device, but the jumpers can be overridden with the Mode parameter in this instruction.

CVO4Source The CVO4Source parameter is a variable array that holds the values for the voltages (millivolts) or currents (microamps) that will be output by each channel of the device (Source(1) sets channel1, Source(2) sets channel2, etc.). When outputting a voltage, the variable must be within the range of 0 to 10,000. When outputting a current, the variable must be within the range of 0 to 20,000.

CVO4Reps The CVO4Reps parameter indicates the number of channels to set to the defined voltage or current. Additional SDM-CVO4 devices can be controlled by one SDMCVO4 instruction by assigning them consecutive addresses and setting the CVO4Reps parameter to a value equal to the total number of channels of all devices (e.g., to set all four channels on two devices, set the CVO4Reps parameter to 8).

If the CVO4Reps parameter is set to 0, power to the device will be turned off.

SDMAddress The SDMAddress parameter defines the address of the SDM-CVO4 which will be affected by this instruction. Valid SDM addresses are 0 through 14. Address 15 is reserved for the SDMTrigger instruction.

NOTE

CRBasic dataloggers use base 10 when addressing SDM devices. Edlog programmed dataloggers (e.g., CR10X, CR23X) used base 4 for addressing.

CVO4Mode The CVO4Mode determines what type of signal will be output by the device. The options are:

Option	Description
0	Voltage output, use jumper settings (scale only)
1	Current output; use jumper settings (scale only)
10	Voltage output; override jumper setting
11	Current output; override jumper setting

The two override options (10 and 11) affect all of the channels of all of the SDM-CVO4 devices being controlled by this instruction. These two options override the hardware settings

in the device. Use of this mode takes approximately 2 milliseconds additional time per device. When either of these options is used you lose the flexibility of setting the output mode for each channel individually. Additionally, subsequent programs sent to the datalogger must also use an override mode or the power must be cycled on the device to return it to its default state. Otherwise, if 0 or 1 is entered it will be ignored and the device will remain in its last override state.

NOTE Current output requires an external resistor from Id to +V.

6.2 SDMCVO4 Instruction Example

This program example is for a weather station measuring wind speed, wind direction, temperature, and relative humidity. Each parameter is scaled to 0 to 10000 mVDC, and output to a SCADA system through the SDM-CVO4.

```
Public WS_ms
Public WD_0_360
Public Temp_C
Public RH
Public WD_0_540
Public Flag
Public CVO4Output(4)
Alias CVO4Output(1) = WSOut
Alias CVO4Output(2) = WDOut
Alias CVO4Output(3) = TempOut
Alias CVO4Output(4) = RHOut

'Code for DataTable OneMin
DataTable(OneMin,1,-1)
  DataInterval(0,1,Min,0)
  WindVector (1, WS_ms,WD_0_360, IEEE4, 0, 0, 0, 0)
  Average(1,Temp_C,IEEE4,0)
  Sample(1,RH, IEEE4)
EndTable

BeginProg
  Scan(1,Sec,1,0)
  ' Code for 03001 wind measurements, WS_ms & WD_0_360:

PulseCount(WS_ms, 1, 1, 1, 1, 0.75, 0.2)
  BrHalf(WD_0_360, 1,mV1000, 1, 1, 1, 1000, True, 1000, 250, 355, 0)
  ' Code for CS500 measurement, AirTC and RH:
  VoltSE(Temp_C,1,mV1000,3,0, 0, _60Hz,0.1,-40.0)
  VoltSE(RH,1,mV1000,2,0, 0, _60Hz,0.1, 0)
  ' Call Data Table
  CallTable(OneMin)
  ' Convert 0-360 WD to 0-540:
  If WD_0_540 >= 270 and WD_0_360 <180 Then
    WD_0_540 = WD_0_360 + 360
```

```

Else
    WD_0_540 = WD_0_360
EndIf
' Scale the measurements for the SDM-CVO4 to output 0-10000 mV
WSOut = WS_ms*200 'WS: 0-50 m/s = 0-10000 mV
WDOut = WD_0_540 *18.59 'WD: 0-540 deg = 0-10000mV
TempOut= 100*(Temp_C+40) 'Temp: -40-60 deg C = 0-10000 mV
RHOut = RH *100 'RH: 0-100 % RH = 0-10000 mV
' Send mV outputs to SDM-CVO4 using the option to override the switch settings
SDMCVO4 (CVO4Output(),4,0,10)
NextScan
EndProg

```

6.3 SDMSpeed Instruction

Changes the rate that a CR800, CR850, CR1000, CR3000, or CR5000 uses to clock the SDM data. Slowing down the clock rate may be necessary when long cables lengths are used to connect the datalogger and SDM devices.

TABLE 6-1. Description of SDM Speed

Parameter & Data Type	Enter
BitPeriod <i>Constant or variable</i>	The time per bit, in microseconds. Initial Setting (default): 26.04 μ S Resolution: 8.68 μ S Min Setting: 8.68 μ S Max Setting: 2.2 mS SDMSpeed(30) gives: 26.04 μ S SDMSpeed(k) gives: $\text{bit_rate} = \text{INT}((k*72)/625) *$ Resolution When calculating SDMSpeed(k), the loggers round down to the next higher bit.

6.4 Edlog Instruction 103

To allow full backwards compatibility with older dataloggers and operating systems, the SDM-CVO4 is designed to work with the instruction supplied to control the SDM-AO4 – Instruction 103. However, most datalogger manuals and program editor help systems do not refer to the SDM-CVO4 in the description of Instruction 103. Please see the details of use below to understand the differences.

Instruction 103 is described in Table 6-2 and allows you to set four separate output levels for one SDM-CVO4, or several output levels with multiple SDM-CVO4s. Output levels are reset each time Instruction 103 is executed.

Instruction 103 was originally designed to take an input location range of -5000 to +5000 and output this directly in mV when using the SDM-AO4. When used with the SDM-CVO4, the same range of values (± 5000) in an input

location is used to scale the output to 0-10000mV for voltage mode, or 0-20 mA for current output mode.

In most applications a specific range of a measured value is scaled to utilize the full scale output of SDM-CVO4. For instance, a temperature sensor reading in the range of -20°C to $+50^{\circ}\text{C}$ would be scaled so at -20°C the output is 0 mV and at $+50^{\circ}\text{C}$ the output is 10000 mV. To do this with the SDM-CVO4 you would use the mathematical functions of the datalogger to calculate a scaled value in a new input location, so that the value is -5000 when the temperature is -20°C and +5000 at $+50^{\circ}\text{C}$.

The datalogger limits the output of the SDM-CVO4 so that even if the measured value exceeds the intended range (i.e. the scaling value exceeds ± 5000) the signal output is limited to the equivalent output at -5000 or +5000. Therefore the datalogger instruction does not normally need to have extra instructions to limit the scaling value range. However for displays or input devices which require a current signal of 4-20 mA, the datalogger program needs to include extra instructions to prevent the scaling value going below - 3000 (see the examples below) and thereby setting the lowest possible output to 4 mA.

When checking the output of the SDM-CVO4 against the scaling value you should be aware that the output changes in discrete steps, e.g. 2.5 mV in voltage mode. When the datalogger works out which of these discrete steps to set for a given scaling value, a combination of floating point mathematics followed by truncation to an integer value is made. This will sometimes result in the transition from one output step to the next not happening at the exact midpoint value of each 2.5 mV step, although it should happen within a limit of ± 0.5 in terms of the scaling value stored in the input location.

The number of repetitions, parameter 1, specifies the total number of SDM-CVO4 output channels to be set. The address of the first SDM-CVO4 is specified with parameter 2; multiple SDM-CVO4s must have consecutive addresses. Parameter 3 is the starting input location containing the scaling value for the first output channel of the first SDM-CVO4. Subsequent scaling values must be contained in consecutive input locations immediately after the first input location specified in parameter 3.

For example, two SDM-CVO4s can be used to output eight signals, which are contained in input locations 15 to 22. There are eight repetitions, and so eight (8) is entered for parameter 1. The SDM-CVO4s must have consecutive addresses (e.g. 31 and 32), and so parameter 2 would contain 31 in this case. Fifteen (15) would be entered for parameter 3.

TABLE 6-2. Description of Instruction 103

Par. Number	Data Type	Description
01:	2	Reps — Number of analog outputs
02:	2	Address of SDM-CVO4 in base 4 (00 to 33)
03:	4	Input loc. holds scaling value for the output level

Setting the Reps parameter to 0 (Zero) will cause the addressed SDM-CVO4 to shut down, turning off all its outputs. It will turn on channels 1 and 2 at the next execution of Instruction P103 where the reps parameter is 1 or 2. If the reps parameter is greater than 2, then all the channels will be turned on.

Refer to the manual for the datalogger being used for full details of the execution time of Instruction 103. All of the outputs of the SDM-CVO4 will change simultaneously approximately 10ms after the instruction is completed by the datalogger, or 100ms after power-up.

If the SDM-CVO4 loses power for any reason, when power is restored the outputs will return to the default 'off' state. This will be held until the datalogger runs Instruction 103 again to update the output levels required.

6.5 Edlog Program Examples

The following Edlog program examples are given to help you understand the general principles involved in the use of the SDM-CVO4.

6.5.1 Voltage and 0-20 mA Current Output Modes

This program example is for a simple weather station with a CR23X Micrologger measuring wind speed, wind direction, temperature and solar radiation. Each parameter is scaled to the full-scale output range of the SDM-CVO4 which would be 0-10,000 mV DC or 0-20 mA, depending on the output jumper settings. Programming for the CR10X is very similar.

```

; {CR23X}
; Example weather station program to show scaling values
; for the SDM-CVO4

*Table 1 Program
01: 1      Execution Interval (seconds)

; Measure the output from a switch closure anemometer (A100R)

1: Pulse (P3)
1: 1      Reps
2: 1      Pulse Channel 1
3: 22     Switch Closure, Output Hz
4: 1      Loc [ WindSpeed ]
5: 1.25   Mult ; Scale to m/s
6: 0.0    Offset

```

; Measure the wind direction from a potentiometer windvane

2: Excite-Delay (SE) (P4)

1: 1 Reps
 2: 14 1000 mV, Fast Range
 3: 1 SE Channel
 4: 1 Excite all reps w/Exchan 1
 5: 1 Delay (units 0.01 sec)
 6: 1000 mV Excitation
 7: 2 Loc [WindDir]
 8: 0.357 Mult ; Scale to angle in degrees
 9: 0.0 Offset

; Measure air temperature from a 107 probe

3: Temp (107) (P11)

1: 1 Reps
 2: 2 SE Channel
 3: 31 Excite all reps w/E1, 50Hz, 10ms delay
 4: 3 Loc [AirT]
 5: 1.0 Mult ; Scale to degrees C
 6: 0.0 Offset

; Measure solar radiation from an SP-Lite

4: Volt (SE) (P1)

1: 1 Reps
 2: 32 50 mV, 50 Hz Reject, Slow Range
 3: 3 SE Channel
 4: 4 Loc [Radiation]
 5: 100 Mult
 6: 0.0 Offset

; Now output data in the normal way to final storage

5: If time is (P92)

1: 0 Minutes (Seconds --) into a
 2: 1 Interval (same units as above)
 3: 10 Set Output Flag High (Flag 0)

6: Real Time (P77)

1: 110 Day,Hour/Minute (midnight = 0000)

7: Wind Vector (P69)

1: 1 Reps
 2: 0 Samples per Sub-Interval
 3: 0 S, é1, & â(é1) Polar
 4: 1 Wind Speed/East Loc [WindSpeed]
 5: 2 Wind Direction/North Loc [WindDir]

8: Average (P71)

1: 2 Reps
 2: 3 Loc [AirT]

; Now the code to scale the values and update the SDM-CVO4

```

; As we have four channels to output, we will first copy the
; current readings with P54, block move, in a block of four
; input locations to hold the scaled outputs

```

9: Block Move (P54)

```

1: 4      No. of Values
2: 1      First Source Loc [ WindSpeed ]
3: 1      Source Step
4: 5      First Destination Loc [ ScldOut_1 ]
5: 1      Destination Step

```

```

; Then apply the scaling with one Instruction P53
; The readings are scaled -5000 to +5000, i.e. to
; cover the full scale range which would equate to
; 0 - 10,000 mV in voltage mode or 0-20 mA in
; current mode.

```

```

; Windspeed to cover the range 0-100 m/s
; Wind direction to cover 0-360 degrees
; Temperature -25 to +50 degrees C
; Radiation 0 - 1000 m^2/s

```

10: Scaling Array (A*Loc+B) (P53)

```

1: 5      Start Loc [ ScldOut_1 ]
2: 100    A1 ; WS multiplier
3: -5000  B1 ; WS Offset
4: 27.7778 A2
5: -5000  B2
6: 133.333 A3
7: -1666.67 B3
8: 10     A4
9: -5000  B4

```

```

; Now update the SDM-CVO4 with the information
; for the four channels

```

11: SDM-AO4 (P103)

```

1: 4      Reps
2: 30     SDM Address
3: 5      Loc [ ScldOut_1 ]

```

6.5.2 Restricted Range Current Output Modes (4-20 mA)

When driving a system that requires a restricted current range then the full-scale range is reduced accordingly. In the case of 4-20 mA devices the maximum range is 8000 units and the minimum value should be scaled to -3000 and prevented from going below this level.

The following partial program could be used in place of the last two instructions in the example above.

```

; Then apply the scaling with one instruction P53
; The readings are scaled -3000 to +5000, i.e. to
; cover the range which would equate to
; 4-20 mA in current mode.

; Windspeed to cover the range 0-100 m/s
; Wind direction to cover 0-360 degrees
; Temperature -25 to +50 degrees C
; Radiation 0 - 1000 m^2/s

10: Scaling Array (A*Loc+B) (P53)
  1: 5      Start Loc [ ScldOut_1 ]
  2: 80     A1 ; WS multiplier
  3: -3000  B1 ; WS Offset
  4: 22.2222 A2
  5: -3000  B2
  6: 106.667 A3
  7: -333.32 B3
  8: 8      A4
  9: -3000  B4

; Now limit the lowest scaled value to -3000 (4 mA)
; As we have four 4-20 mA current outputs, a loop
; construct is the easiest way to do this.

11: Beginning of Loop (P87)
  1: 0000   Delay
  2: 4      Loop Count

; If the scaled value is less the -3000

  12: If (X<=>F) (P89)
    1: 5      -- X Loc [ ScldOut_1 ]
    2: 4      <
    3: -3000  F
    4: 30     Then Do

; then set the value to -3000

    13: Z=F (P30)
      1: -3000  F
      2: 00     Exponent of 10
      3: 5      -- Z Loc [ ScldOut_1 ]

  14: End (P95)

15: End (P95)

```

```

; Now update the SDM-CVO4 with the information
; for the four channels

```

```

16: SDM-AO4 (P103)
   1: 4      Repts
   2: 30     SDM Address
   3: 5      Loc [ SclOut_1 ]

```

6.5.3 Providing Isolated Power Supplies to Sensors

This program example sets all the outputs of the SDM-CVO4 to 10 V to provide isolated power supplies to four separate sensors. The program includes code to put the SDM-CVO4 into standby mode after the measurements are made.

```

; {CR10X}
; An example program which show use of the SDM-CVO4
; as an isolated power supply for 4 sensors requiring
; 10 V drive and producing 0-100 mV signals.
; This shows how to set the SDM-CVO4 into standby mode.

```

```

*Table 1 Program

```

```

01:          60                      Execution Interval (seconds)

```

```

; Store a fixed value of 5000 = 10 V output
; in the four scaling locations

```

```

1: Bulk Load (P65)
   1: 5000    F
   2: 5000    F
   3: 5000    F
   4: 5000    F
   5: 0.0     F
   6: 0.0     F
   7: 0.0     F
   8: 0.0     F
   9: 1       Loc [ Scale_1 ]

```

```

; Tell the SDM-CVO4 to set all four outputs to 10,000 mV
; The SDM-CVO4 address is zero in this example.
; This will cause the SDM-CVO4 to come out of standby
; mode.

```

```

2: SDM-AO4 (P103)
   1: 4      Repts
   2: 00     SDM Address
   3: 1      Loc [ Scale_1 ]

```

```

; Wait 100 ms for it to power-on and the outputs to stabilize
; You may need to increase this delay if the sensors themselves
; have a power-on delay

```

3: Excitation with Delay (P22)

```

1: 1      Ex Channel
2: 0000   Delay W/Ex (units = 0.01 sec)
3: 10     Delay After Ex (units = 0.01 sec)
4: 0000   mV Excitation

```

```

; Take the four measurements from the Pressure sensors.

```

4: Volt (Diff) (P2)

```

1: 4      Reps
2: 04     250 mV Slow Range
3: 1      DIFF Channel
4: 5      Loc [ Press_1 ]
5: 1.0    Mult
6: 0.0    Offset

```

```

; Now turn off the SDM-CVO4 by using the command with 0 reps.

```

5: SDM-AO4 (P103)

```

1: 0      Reps
2: 00     SDM Address
3: 1      Loc [ Scale_1 ]

```

```

; Now the normal output processing and final storage
; instructions would follow, for example:

```

```

; Every hour set the output flag

```

6: If time is (P92)

```

1: 0      Minutes (Seconds --) into a
2: 60     Interval (same units as above)
3: 10     Set Output Flag High (Flag 0)

```

```

; Store time

```

7: Real Time (P77)

```

1: 1110   Year,Day,Hour/Minute (midnight = 0000)

```

```

; Store the average readings

```

8: Average (P71)

```

1: 4      Reps
2: 5      Loc [ Press_1 ]

```

Campbell Scientific Companies

Campbell Scientific, Inc. (CSI)

815 West 1800 North
Logan, Utah 84321
UNITED STATES
www.campbellsci.com • info@campbellsci.com

Campbell Scientific Africa Pty. Ltd. (CSAf)

PO Box 2450
Somerset West 7129
SOUTH AFRICA
www.csafrica.co.za • cleroux@csafrica.co.za

Campbell Scientific Australia Pty. Ltd. (CSA)

PO Box 444
Thuringowa Central
QLD 4812 AUSTRALIA
www.campbellsci.com.au • info@campbellsci.com.au

Campbell Scientific do Brazil Ltda. (CSB)

Rua Luisa Crapsi Orsi, 15 Butantã
CEP: 005543-000 São Paulo SP BRAZIL
www.campbellsci.com.br • suporte@campbellsci.com.br

Campbell Scientific Canada Corp. (CSC)

11564 - 149th Street NW
Edmonton, Alberta T5M 1W7
CANADA
www.campbellsci.ca • dataloggers@campbellsci.ca

Campbell Scientific Centro Caribe S.A. (CSCC)

300 N Cementerio, Edificio Breller
Santo Domingo, Heredia 40305
COSTA RICA
www.campbellsci.cc • info@campbellsci.cc

Campbell Scientific Ltd. (CSL)

Campbell Park
80 Hathern Road
Shepshed, Loughborough LE12 9GX
UNITED KINGDOM
www.campbellsci.co.uk • sales@campbellsci.co.uk

Campbell Scientific Ltd. (France)

3 Avenue de la Division Leclerc
92160 ANTONY
FRANCE
www.campbellsci.fr • info@campbellsci.fr

Campbell Scientific Spain, S. L.

Avda. Pompeu Fabra 7-9, local 1
08024 Barcelona
SPAIN
www.campbellsci.es • info@campbellsci.es

Please visit www.campbellsci.com to obtain contact information for your local US or International representative.