

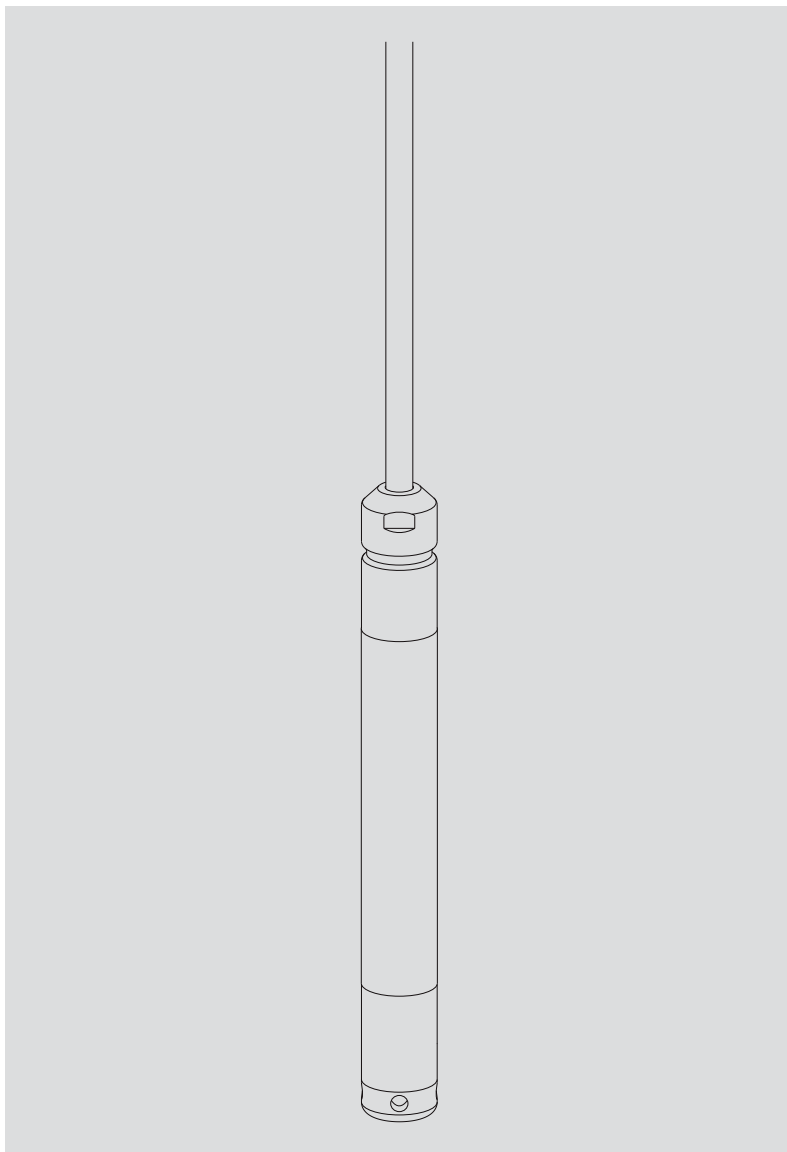

Operating instructions
Pressure Probe OTT PLS



English

We reserve the right to make technical changes and improvements without notice.

WARRANTY AND ASSISTANCE

This equipment is warranted by CAMPBELL SCIENTIFIC (CANADA) CORP. ("CSC") to be free from defects in materials and workmanship under normal use and service for **twelve (12) months** from date of shipment unless specified otherwise. ***** **Batteries are not warranted.** ***** CSC's obligation under this warranty is limited to repairing or replacing (at CSC's option) defective products. The customer shall assume all costs of removing, reinstalling, and shipping defective products to CSC. CSC will return such products by surface carrier prepaid. This warranty shall not apply to any CSC products which have been subjected to modification, misuse, neglect, accidents of nature, or shipping damage. This warranty is in lieu of all other warranties, expressed or implied, including warranties of merchantability or fitness for a particular purpose. CSC is not liable for special, indirect, incidental, or consequential damages.

Products may not be returned without prior authorization. To obtain a Return Merchandise Authorization (RMA), contact CAMPBELL SCIENTIFIC (CANADA) CORP., at (780) 454-2505. An RMA number will be issued in order to facilitate Repair Personnel in identifying an instrument upon arrival. Please write this number clearly on the outside of the shipping container. Include description of symptoms and all pertinent details.

CAMPBELL SCIENTIFIC (CANADA) CORP. does not accept collect calls.

Non-warranty products returned for repair should be accompanied by a purchase order to cover repair costs.



CAMPBELL SCIENTIFIC
C A N A D A C O R P .

11564 - 149 street - edmonton - alberta - T5M 1W7
tel 780.454.2505 fax 780.454.2655

www.campbellsci.ca

Table of contents

1 Scope of Supply	4
2 Order Numbers	4
3 Basic safety instructions	5
4 Introduction	6
5 Installing the pressure probe	8
5.1 Installation type A: fixing the pressure probe into a protective device	8
5.2 Installation type B: hanging pressure probe	9
5.3 Connecting humidity absorbing system	10
5.4 Wire assignment of the pressure probe cable	10
5.5 Connecting the OTT PLS to any datalogger using an SDI-12 interface	11
5.6 Connecting the OTT PLS to any datalogger using a 4 ... 20 mA interface	11
5.7 Determining the maximum load resistance at the 4 ... 20 mA interface	11
5.8 Note on using the 4 ... 20 mA interface	12
5.9 Note on using the RS-485 interface	12
6 SDI-12 Commands and Responses	13
6.1 Standard commands	13
6.2 Advanced SDI-12 commands	15
7 Carrying out maintenance work	20
8 Searching for disruptions/troubleshooting	21
9 Repair	22
10 Note about the disposal of old units	22
11 Technical Data	23
Appendix A – Installing the FAD 4PF humidity absorbing system	25
Appendix B – Connecting the OTT PLS to the LogoSens 2 or DuoSens using an SDI-12 or RS-485 interface	26
Appendix C – Connecting the OTT PLS to the LogoSens 2 or DuoSens using a 4 ... 20 mA interface	28
Appendix D – Declaration of conformity for the OTT PLS	30
Appendix E – CR1000 Wiring Options	31

1 Scope of supply

- ▶ **OTT PLS**
 - 1 Pressure probe with a ceramic, capacitive, relative pressure measuring cell and shielded pressure probe cable with pressure compensation capillary and Kevlar core for length stabilization. Pre-fabricated cable end with transport protection against moisture.
 - 1 Set of operating instructions
 - 1 Factory acceptance test certificate (FAT)

2 Order numbers

- ▶ **OTT PLS**
 - OTT PLS pressure probe** 63.037.001.9.2
 - Version with 4 ... 20 mA interface
 - Version with SDI-12 interface
 - Version with RS-485 interface (SDI-12 protocol)
 - Required order information:
 - Measuring range (0 ... 4 m, 0 ... 10 m, 0 ... 20 m, 0 ... 40 m)
 - System length (1 ... 200 m, $\pm 0.5 \% \pm 0.05$ m)
- ▶ **Accessories**
 - Humidity absorbing system FAD 4PF** 63.025.021.4.2
 - desiccant cartridge in clear container with connection tube for pressure compensation capillary
 - FAD 5 humidity absorbing system** 63.037.025.3.2
 - connecting box (pressure probe cable ↔ connection cable datalogger/voltage supply) with desiccant cartridge
 - Desiccant cartridge** 97.100.066.4.5
 - replacement cartridge in transport container
 - Cable attachment, straight** 96.140.173.9.5
 - Cable attachment, angled** 20.450.133.4.1
 - Connection cable** 97.000.040.9.5
 - twisted pair construction; LiYY
 - PVC, black
 - $2 \times 2 \times 0.75$ mm²
 - unshielded
 - Connection cable** 97.000.039.9.5
 - twisted pair construction; FD CP (TP)
 - PVC, gray
 - $2 \times 2 \times 0.5$ mm²
 - shielded

3 Basic safety information



- ▶ Read these operating instructions before using the OTT PLS for the first time! Make yourself completely familiar with the installation and operation of the OTT PLS! Retain these operating instructions for later reference.
- ▶ The OTT PLS is used for measuring the water level of ground and surface waters in hydrometry. Only use the OTT PLS as described in these operating instructions!
For further information, → see Chapter 4, *Introduction*.
- ▶ Note all the detailed safety information given within the individual work steps. All safety information in these operating instructions are identified with the warning symbol shown here.
- ▶ Ensure the electrical, mechanical, and climatic specifications listed in the technical data are adhered to.
For further information → see Chapter 11, *Technical data*.
- ▶ Do not make any changes or retrofits to the OTT PLS. If changes or retrofits are made, all guarantee claims are voided.
- ▶ Have a faulty OTT PLS inspected and repaired by our repair center. On no account carry out repairs yourself!
For further information → see Chapter 9, *Repair*.
- ▶ Dispose of the OTT PLS properly after taking out of service. On no account put the OTT PLS into the normal household waste.
For further information → see Chapter 10, *Note about the disposal of old units*.

4 Introduction

The OTT PLS pressure probe is used for precisely measuring the water level of ground and surface waters. The pressure probe uses the hydrostatic pressure of the water column above a relative pressure measuring cell to do so. A pressure compensation capillary in the pressure probe cable gives the measuring cell the current ambient air pressure as a reference. Erroneous measurement results due to atmospheric air pressure fluctuations are thus eliminated.

The OTT PLS can be supplied with various measuring ranges:

- ▶ 0 ... 4 m water column (0 ... 0.4 bar)
- ▶ 0 ... 10 m water column (0 ... 1 bar)
- ▶ 0 ... 20 m water column (0 ... 2 bar)
- ▶ 0 ... 40 m water column (0 ... 4 bar)

Furthermore, the pressure probe can be supplied with either an analog or digital interface:

- ▶ 4 ... 20 mA interface (with additional RS-485 interface (SDI-12 protocol) for configuring the 4 ... 20 mA interface*)
- ▶ SDI-12 interface
- ▶ RS-485 interface (SDI-12 protocol)

The pressure probe with the SDI-12/RS-485 interface can be configured via the SDI-12 transparent mode of a datalogger. For example, a reference value or offset value can be entered when starting up the device. With the 4 ... 20 mA version, it is possible to scale the measured value output to a smaller measuring range using the additional RS-485 interface available (SDI-12 protocol).

A particular feature is that the pressure probe measures the water temperature as well as the hydrostatic pressure of the water column and thus yields highly precise and reproducible measurement results by compensating the effects of temperature, specific density of the water and the local gravitational acceleration at the specific station. (For this, the specific density and local gravitational acceleration are entered as required during startup.)

At the SDI-12 and RS-485 interfaces, the OTT PLS outputs either the water level (compensated) or the hydrostatic pressure as well as the water temperature: at the 4 ... 20 mA interface, either the water level (compensated) or hydrostatic pressure. Measurement units can be set with SDI-12 commands as m / cm / ft (water level measurement), mbar / psi (pressure measurement) and °C / °F (temperature measurement).

The properties mentioned enable the universal operation of the pressure probe: for example for connection to a datalogger, controlling pen recorders, alarm devices, switching contacts, and, together with a display, for the display of measured values.

A humidity absorbing system for drying the surrounding air that enters the pressure compensation capillary is available as an accessory.

* No parallel operation of the interfaces

Fig. 1: Main layout of a water level station with the OTT PLS pressure probe.

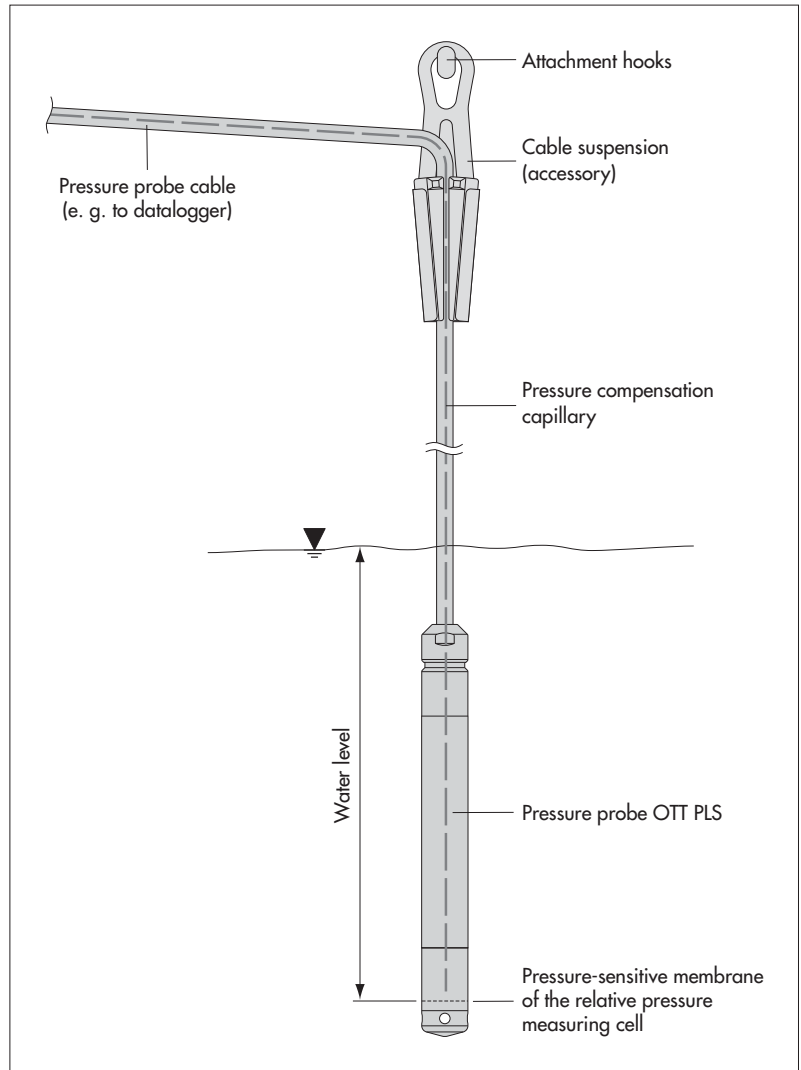

5 Installing the pressure probe

The OTT PLS pressure probe can be used in a variety of ways, for example in observation wells and boreholes from 1" diameter, in shafts, open waterways, and in waterways that do not always hold water.

Caution

We do not recommend installing the pressure probe in the vicinity of port facilities, industrial waste water discharges or areas with heavy chemical contamination. The pressure probe is constructed from high-quality stainless steel and plastic. However, depending on the mounting location, damaging corrosion can arise. For more information on the materials used, see Chapter 11 "Technical data".

The pressure probe can be installed in two ways:

- ▶ fixed in an individual protective device, built on location, or
- ▶ hung on the pressure probe cable.

Caution

No moisture should be allowed to enter the pressure compensation capillary of the pressure probe cable during installation! Very high air humidity can also lead to the formation of water droplets in the pressure compensation capillary due to temperature changes. These inevitably lead to unusable measurement results! As a result, ensure the transport protection is left on the cable end during the whole time it is being laid!

5.1 Installation type A: fixing the pressure probe into a protective device

In flowing waters or waterways with a swell, the pressure probe must be fixed. With strong currents ($> 0.5 \dots 1 \text{ m/s}$) the hydrodynamic influences of the station have to be considered in the installation. Depending on the version and mounting of the individual components, overpressure or negative pressure can arise that can affect the measurement result.

- Determine the minimum and maximum water level at your station (e.g. staff gauge, contact gauge). Use both values to specify the probe position. The following conditions must be fulfilled:
 - position the probe below the minimum water level if possible;
 - difference between max. water level and position of the probe $<$ measuring range of the probe.
- Fix the pressure probe according to your individual requirements in a protective device, as shown in Figure 2, for example.

Note

The fine setting of the probe position is carried out, for example, by entering a reference or offset value (with SDI-12/RS-485 interface) or using a scaling function of the datalogger connected.

Fig. 2: Installation example of the OTT PLS pressure probe in open waterways.

With waterways with currents or swell, a fixing pin is used to securely fasten the probe. Push the fixing pin through the holes in the black protective cap.

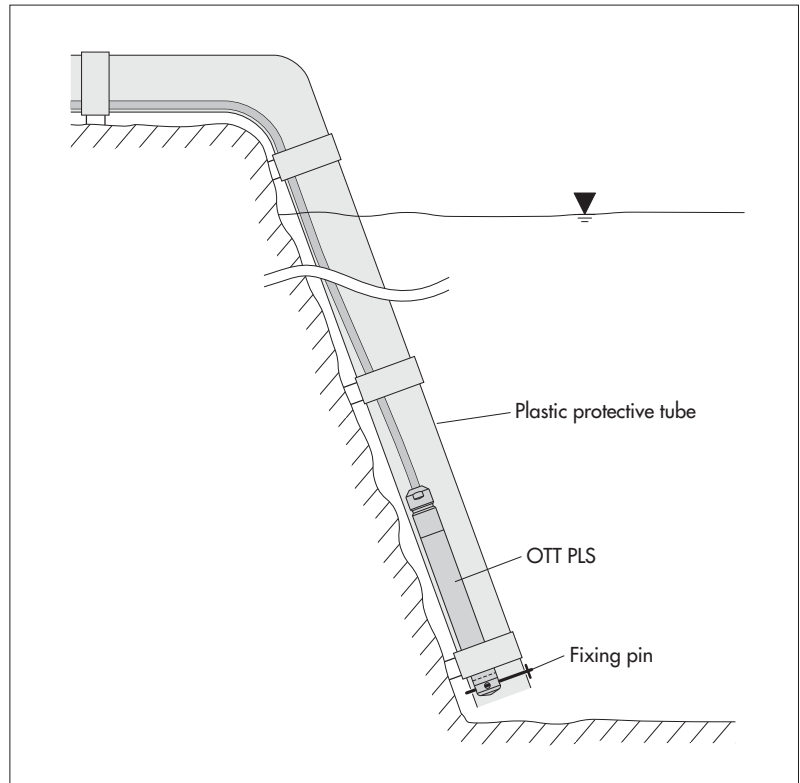

5.2 Installation type B: hanging pressure probe

See also Figure 1.

- Determine the minimum and maximum water level at your station (e.g. staff gauge, contact gauge). Use both values to specify the probe position. The following conditions must be fulfilled:
 - position the probe below the minimum water level if possible;
 - difference between max. water level and position of the probe < measuring range of the probe.
- Fix the cable attachment (accessory) at a suitably sized attachment point.
- Carefully lower the pressure probe on the pressure probe cable to the specified depth. There are markings on the cable every 0.25 m to assist orientation.
- Lay the pressure probe cable in the opened clamping jaws of the cable attachment as shown in Figure 1 and secure the pressure probe cable by pushing the clamping jaws together. The mechanical longitudinal stability required is provided by Kevlar fibers inside the pressure probe cable. **Caution:** maximum hanging depth: 50 m. (greater depths on request).

Notes

- ▶ The fine setting of the probe position is carried out, for example, by entering a reference or offset value (with SDI-12/RS-485 interface) or using a scaling function of the datalogger connected. It is thus sufficient in many applications to position the probe approximately.
- ▶ If the pressure probe cable ends in the immediate vicinity of the cable attachment: fix the Kevlar fibers at a suitable point in addition!

5.3 Connecting humidity absorbing system

A humidity absorbing system must be installed for drying the surrounding air that enters the pressure compensation capillary of the pressure probe cable! See Appendix A.

Caution

Humidity entering the pressure compensation capillary leads to unusable measurement results!

5.4 Wire assignment of the pressure probe cable

Fig. 3: Wire assignment of the OTT PLS pressure probe cable.

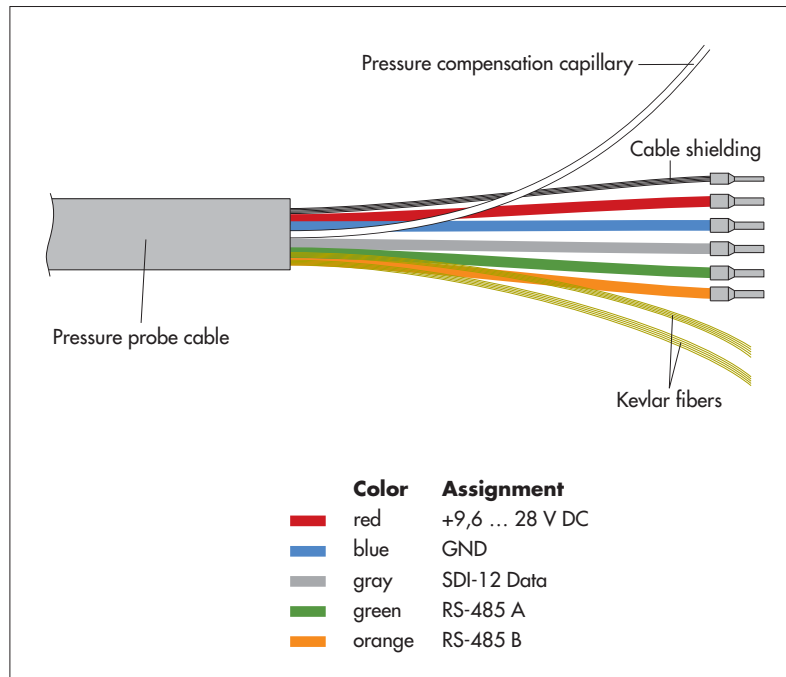

Caution

The factory assembled pressure probe cable should only be shortened with a suitable wire stripping tool! Danger of damaging the cable!
Recommendation: Store excess cable in loops if necessary!

If necessary, the pressure probe cable can be lengthened. For this purpose, use a suitable junction box (e.g. FAD 5). This should also be large enough to hold the humidity absorbing system. The maximum cable length for the RS-485 interface and the 4 ... 20 mA interface is 1,000 m. Recommended cable type for the RS-485 interface: shielded, twisted-pair cable. The wires intended for the power supply can be twisted pair, but do not have to be. Recommended cable type for the 4 ... 20 mA interface: unshielded, low-voltage cable. If the additional RS-485 interface (configuring the 4 ... 20 mA interface) is also to be fed to the datalogger, a twisted pair cable is also necessary in this case.

Suitable wire sizes

- ▶ Up to 500 m cable length: 2 x 2 x 0.5 mm² (41 Ohm/1,000 m)
- ▶ 500 to 1,000 m cable length: 2 x 2 x 0.75 mm² (27 Ohm/1,000 m)

5.5 Connecting the OTT PLS to any datalogger using an SDI-12 interface

- Connect the OTT PLS to an SDI-12 input of the datalogger. Follow the datalogger handbook when doing this. Refer to Figure 4 for the wire assignments of the OTT PLS. Wires used: red, blue, and gray. The maximum length of the cable is 65 m.
- To achieve better protection against overloads, you can optionally connect the cable shielding to a grounding point/equipotential busbar.

Fig. 4: Wires used with an SDI-12 interface.

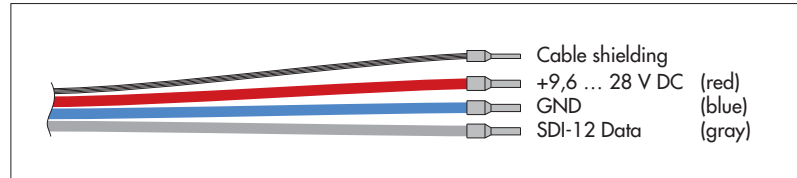

The SDI-12 commands and responses used with the OTT PLS can be found in Chapter 6, SDI-12 Commands and Responses.

5.6 Connecting the OTT PLS to any datalogger using a 4 ... 20 mA interface

- Connect the OTT PLS to a 4 ... 20 mA input of the datalogger. Follow the datalogger handbook when doing this. Refer to Figure 5 for the connection assignments of the OTT PLS. Wires used: red and blue.
Maximum cable length: dependent on the level of the supply voltage and size of the burden (load resistor). Ensure that the ohmic resistance of the pressure probe cable together with any burden present does not exceed the maximum permitted load resistance (see Chapter 5.7). The upper limit for the cable length is 1,000 m in all cases.
- To achieve better protection against overloads, you can optionally connect the cable shielding to a grounding point/equipotential busbar.

Fig. 5: Wires used with a 4 ... 20 mA interface.

If the OTT PLS is to be configured via the RS-485 interface, the green and orange wires are required in addition.

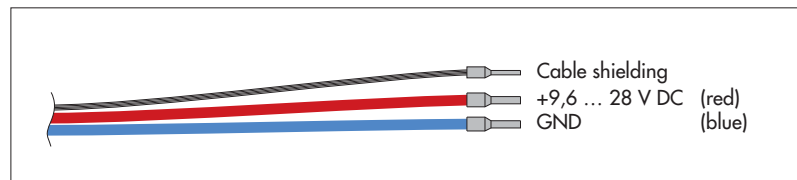

5.7 Determining the maximum load resistance at the 4 ... 20 mA interface

The load resistance (burden + ohmic resistance of the connection cable) connected to the OTT PLS must not exceed a specific maximum value. This value depends on the level of the supply voltage of the OTT PLS. If the load resistance is greater, the loop current* can no longer be evaluated. Smaller load resistances are allowed.

* Due to the imposed (controlled) current by the OTT PLS of the 4 ... 20 mA interface ($\hat{=}$ measured value)

- See the following diagram for the maximum load resistance applicable to your power supply. Alternatively, the maximum load resistance can be calculated according to the formula:

$$R_{\text{load (max)}} = U_{\text{supply}} - 8.5 \text{ V} / 0.025 \text{ mA}$$

Example: Power supply 24 Volt → max. load resistance 620 Ohm.

The OTT PLS delivers a loop current corresponding to the measured value for a load resistance of up to 620 Ohm.

- Dimension the connected electrical circuit accordingly. Check the input resistance of the connected peripheral device for this purpose.

Fig. 6: Diagram to determine the maximum load resistance as a function of the power supply.

Minimum power supply: 9.6 V
 Maximum power supply: 28 V
 Burden tolerance: 0.1 %/15 ppm.
 (Burden = load resistor).

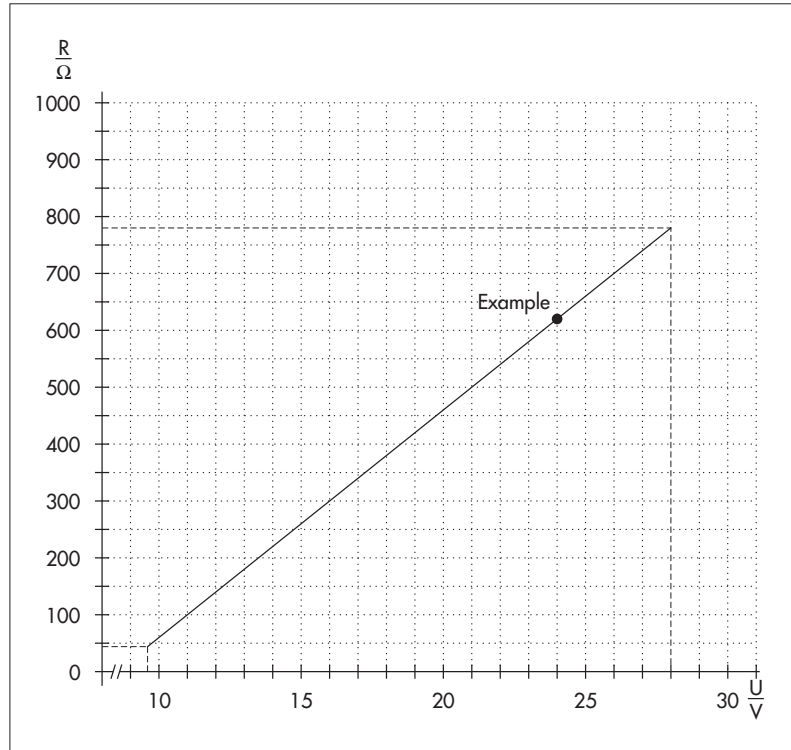

5.8 Note on using the 4 ... 20 mA interface

- ▶ Behavior when switching on the 4 ... 20 mA interface
 After providing the supply voltage, it takes approx. 7 seconds for the loop current to take on the value proportional to the water level. (In the first 7 seconds, the loop current is between 3 and 4 mA.) Afterwards, the pressure probe updates the loop current every 2 seconds.
- ▶ Loop current when configuring the 4 ... 20 mA interface
 If there is a communication via the RS-485 interface, the loop current is higher than the appropriate level for the measured value by several mA. After the end of the communication, it takes approx. 250 ms until the loop current takes on the appropriate value again.

5.9 Note on using the RS-485 interface

The RS-485 interface can only be used with OTT dataloggers. In this case, the transmission protocol via the physical RS-485 interface is the SDI-12 protocol. Connecting OTT PLS via the RS-485 interface to the OTT LogoSens/DuoSens → see Appendix B, Method B.

6 SDI-12 Commands and Responses

6.1 Standard commands

All SDI-12 standard commands are implemented in the OTT PLS. The following SDI-12 standard commands are relevant for the operation of the OTT PLS:

Command	Response	Description
a!	a<CR><LF>	Confirmation active a – sensor address; factory setting = 0
aI!	a13ccccccccmmmmmm vvvxxxx<CR><LF>	Send identification a – Sensor address 13 – SDI-12 protocol version cccccccc – manufacturer identification (company name) mmmmmm – Sensor identification vvv – Sensor version (firmware) xxxxxx – Serial number Answer OTT PLS = 0130TTHACHPLS000100123456
aAb!	b<CR><LF>	Change sensor address a – old sensor address b – new sensor address
?!	a<CR><LF>	Query sensor address a – sensor address
aM!	atttn<CR><LF> and after 2 seconds a<CR><LF>	Starting the measurement a – Sensor address ttt – Time in seconds until the sensor has determined the measurement result Answer OTT PLS = 002 n – Number of measured values Answer OTT PLS = 2 a<CR><LF> – Service request
aD0!	a<value1><value2><CR><LF>	Send data a – sensor address <value1> – level/pressure value measured value formats: m → pbbbb.eee cm → pbbbbbbb ft → pbbbb.ee mbar → pbbbbbb.e psi → pbbbb.eee <value2> – temperature value measured value formats: °C and °F → pbbb.e p – sign (+,-) b – numbers (before the decimal point) Output is without leading zeroes! e – digits after the decimal point
aMC!	atttn<CR><LF> and after 2 seconds a<CR><LF>	Start the measurement and request CRC (Cyclic Redundancy Check). For details see command aM! . The answer to the following aD0! command is extended by a CRC value: a<value1><value2><CRC><CR><LF>
aC!	attnn<CR><LF>	Start concurrent measurement (simultaneous measurement with multiple sensors on one bus feed). For more details, see command aM! . The number of measured values in the answer to this command is two-digit: nn = 02.

Command	Response	Description
aCC!	attnn<CR><LF>	Start concurrent measurement (simultaneous measurement with multiple sensors on one bus feed) and request CRC (Cyclic Redundancy Check). For more details, see command aM!. The number of measured values in the answer to this command is two-digit: nn = 02. The answer to the following aD0! command is extended by a CRC value: a<value1><value2><CRC><CR><LF>
aM1!	attn<CR><LF> and immediately afterwards a<CR><LF>	Query status of the last measurement a – Sensor address ttt – Time in seconds until the sensor has made the result of the system test available Answer OTT PLS = 000 n – Number of measured values Answer OTT PLS = 1 a<CR><LF> – Service request
aD0!	a<value><CR><LF>	Send data (after aM1!, aMC1!, aC1!, aCC1!) a – Sensor address <value> – Status of the last measurement +0 = no hardware defect found +128 = flash memory defective +256 = Watchdog error +512 = memory defective +1024 = pressure cell defective +2048 = D/A converter defective
aMC1!	attn<CR><LF> and immediately afterwards a<CR><LF>	Query the status of the last measurement and request CRC (Cyclic Redundancy Check). For details see command aM!. The answer to the following aD0! command is extended by a CRC value: a<value><CRC><CR><LF>
aC1!	attnn<CR><LF>	Query the status of the last measurement in concurrent mode (simultaneous measurement with multiple sensors on one bus feed). For more details, see command aM! The number of measured values in the answer to this command is two-digit: nn = 02.
aCC1!	attnn<CR><LF>	Query the status of the last measurement in concurrent mode (simultaneous measurement with multiple sensors on one bus feed) and request CRC (Cyclic Redundancy Check). For more details, see command aM! The number of measured values in the answer to this command is two-digit: nn = 02. The answer to the following aD0! command is extended by a CRC value: a<value><CRC><CR><LF>
aV!	attn<CR><LF> and immediately afterwards a<CR><LF>	Carrying out a system test a – Sensor address ttt – Time in seconds until the sensor has made the result of the system test available Answer OTT PLS = 000 n – Number of measured values Answer OTT PLS = 1 a<CR><LF> – Service request

Command	Response	Description
aD0!	a<value><CR><LF>	Send data (after aV!) a – Sensor address <value> – Result of the system test +0 = no hardware defect found +128 = flash memory defective +256 = Watchdog error +512 = memory defective +1024 = pressure cell defective +2048 = D/A converter defective

More information on the SDI-12 standard commands can be found in the document *SDI-12; A Serial-Digital Interface Standard for Microprocessor-Based Sensors, Version 1.3* (see Internet page www.sdi-12.org).

6.2 Advanced SDI-12 commands

All advanced SDI-12 commands begin with an "O" for OTT. With these commands, it is possible to configure the OTT PLS using the transparent mode of a datalogger.

Command	Response	Description
▶ Setting/reading the level/pressure measurement values		
aOSU<value>!	a<value><CR><LF>	Set unit
aOSU!	a<value><CR><LF>	Read out unit
		a – Sensor address
		<value> – Units for level
		+0 = m; factory setting
		+1 = cm
		+2 = ft
		The level measurement is carried out with compensation for water density, water temperature and local gravitational acceleration.
		Units for pressure measurement
		+3 = mbar
		+4 = psi
		Pressure measurement is carried out without compensation!
Caution		
If settings for the parameters "Offset", "Reference value", "Upper limit" or "Lower limit" have been made before changing the unit, they must be reset! There is no automatic conversion of the parameters set!		
▶ Setting/reading the temperature value units		
aOST<value>!	a<value><CR><LF>	Set unit
aOST!	a<value><CR><LF>	Read out unit
		a – Sensor address
		<value> – +0 = °C; factory setting
		+1 = °F

Command	Response
► Set/read local gravitational acceleration	
aOXG<value>!	a<value><CR><LF>
aOXG!	a<value><CR><LF>

Description

Set local gravitational acceleration
Read out local gravitational acceleration

a – Sensor address
<value> – **b.eeeee**
b – numbers before the decimal point
c – numbers after the decimal point
Value range: 9.78036 ... 9.83208 m/s²
factory setting = 9.80665 m/s²

The gravitational acceleration at the earth's surface fluctuates between 9.78036 m/s² at the equator and 9.83208 m/s² at the poles. Also, it decreases by 0.003086 m/s² for each kilometer of elevation above sea level.

Formula for the local gravitational acceleration g in m/s²:

$$g = 9.780356(1 + 0.0052885 \sin^2 \alpha - 0.0000059 \sin^2 2\alpha) - 0.003086 h$$
 α latitude; h = height above sea level in km

(Source: Jursa, A.S., Ed., Handbook of Geophysics and the Space Environment, 4th ed., Air Force Geophysics Laboratory, 1985, pp. 14-17).

Example

Local gravitational acceleration in Kempten: At a height above sea level of 669 m and a latitude of 47.71°, a local gravitational acceleration of 9.80659 m/s² results.

Note

The OTT PLS is preset to an average value for Germany (Kassel). The measurement deviation caused by gravitational acceleration is ±3 mm in Germany (Flensburg – Oberstdorf). This measurement error is compensated by inputting the local gravitational acceleration.

► Set/read average water density

aOXR<value>!	a<value><CR><LF>
aOXR!	a<value><CR><LF>

Set medium water density
Read out medium water density
a – Sensor address
<value> – **b.eeeee**
b – numbers before the decimal point
a – numbers after the decimal point
Value range: 0.50000 ... 2.00000 kg/dm³
Factory setting = 0.99997 kg/dm³ (at 3.98 °C)
With this command you can set the actual density of the water at your station for level/depth measurement. For example, this is worthwhile at stations with brackish water.

► Set/read depth measurement measuring mode

aOAA<value>!	a<value><CR><LF>
aOAA!	a<value><CR><LF>

Set measuring mode depth measurement
Read out measuring mode
a – Sensor address
<value> – +0 = depth measurement measuring mode deactivated
+1 = depth measurement measuring mode activated

Caution

If settings for the parameters "Offset", "Reference value", "Upper limit" or "Lower limit" have been made before changing the measuring mode, they must be reset! There is no automatic conversion of the parameters set!

Command	Response	Description
▶ SDI-12-/RS-485 interface – setting/reading offset for level/depth measurement		
aOAB<value>!	a0022<CR><LF> and after 2 seconds a<CR><LF>	Setting the offset value
aOAB!	a<value><CR><LF>	<p>Reading out the offset value</p> <p>a – Sensor address</p> <p><value> – pbbbb.eee</p> <p>p – sign (+,-)</p> <p>b – numbers (before the decimal point)</p> <p>e – numbers after the decimal point</p> <p>a<CR><LF> – Service request</p> <p>Input/output is without leading zeroes. Value range: -9999.999 ... +9999.999 Factory setting = +0.000</p> <p>With this command you can add a linear offset (positive/negative) to a level/depth measurement value. After setting the offset value, the OTT PLS automatically starts a measurement. After receiving the service request, check the measured value with command aD0!. After an unsuccessful entry, the pressure probe replies with a new service request.</p>
Caution		
This command overwrites any set reference value!		
Example		
Measured value = +10.040 m		
Offset = -0.200 m		
Output = +9.840 m		
Note		
If the unit is changed afterwards (aOSU<value>!), rounding errors of ±0.001 are possible.		
▶ SDI-12-/RS-485 interface – setting/reading reference value for level/depth measurement		
aOAC<value>!	a0022<CR><LF> and after 2 seconds a<CR><LF>	Setting the reference value
aOAC!	a<value><CR><LF>	<p>Reading out the reference value</p> <p>a – Sensor address</p> <p><value> – pbbbb.eee</p> <p>p – sign (+,-)</p> <p>b – numbers (before the decimal point)</p> <p>e – numbers after the decimal point</p> <p>a<CR><LF> – Service request</p> <p>Input/output is without leading zeroes. Value range: -9999.999 ... +9999.999 Factory setting = +0.000</p> <p>With this command you can establish a reference to a level zero, for example, by entering a reference value for level/depth measurement. After setting the reference value, the OTT PLS automatically starts a measurement. After receiving the service request, check the measured value with command aD0!. After an unsuccessful entry, the pressure probe replies with a new service request.</p>

Command **Response**

Description

Caution

This command overwrites any set offset value.

Example

Measured value = +2.100 m
reference value = +1.500 m
output = +1.500 m
(offset calculated by the OTT PLS and applied to all other
measured values = +0.600 m)

Note

If the unit is changed afterwards (**aOSU<value>!**), rounding errors of ± 0.001 are possible.

► 4 ... 20 mA interface – setting/reading the lower limit

aOPA<value>! **a<value><CR><LF>**
aOPA! **a<value><CR><LF>**

Setting the lower limit
Reading out the lower limit
a – Sensor address
<value> – **pbbbb.eee**
p – sign (+,-)
b – numbers (before the decimal point)
e – numbers after the decimal point
Input/output is without leading zeroes!
Value range: -9999.999 ... +9999.999
Factory setting = +0.000

Note

If the unit is changed afterwards (**aOSU<value>!**), rounding errors of ± 0.001 are possible.

► 4 ... 20 mA interface – adjusting/reading the upper limit

aOPB<value>! **a<value><CR><LF>**
aOPB! **a<value><CR><LF>**

Setting upper limit
Reading out upper limit
a – Sensor address
<value> – **pbbbb.eee**
p – Sign (+,-)
b – Numbers (before the decimal point)
e – Numbers after the decimal point
Input/output is without leading zeroes.
Value range: -9999.999 ... +9999.999
Factory setting = +0.000

Note

If the unit is changed afterwards (**aOSU<value>!**), rounding errors of ± 0.001 are possible.

Using the commands *adjust/read the upper/lower limit* you can scale the measurement output of an OTT PLS to a smaller measuring range. Where you do not require the whole measuring range, this has the advantage that a higher resolution for the 4 ... 20 mA interface can be achieved. Example: A measuring range of 16 mA is available for 5 m water level change (e.g. lower limit = +10,000 m; upper limit = +15,000 m. See Figure 7). At the same time, you can use these commands to apply a linear offset (positive/negative) to the measured values of the 4 ... 20 mA interface.

Fig. 7: Scaling measurement output of the 4 ... 20 mA interface to a smaller measuring range.

Example: OTT PLS with measuring range 0 ... 20 m.

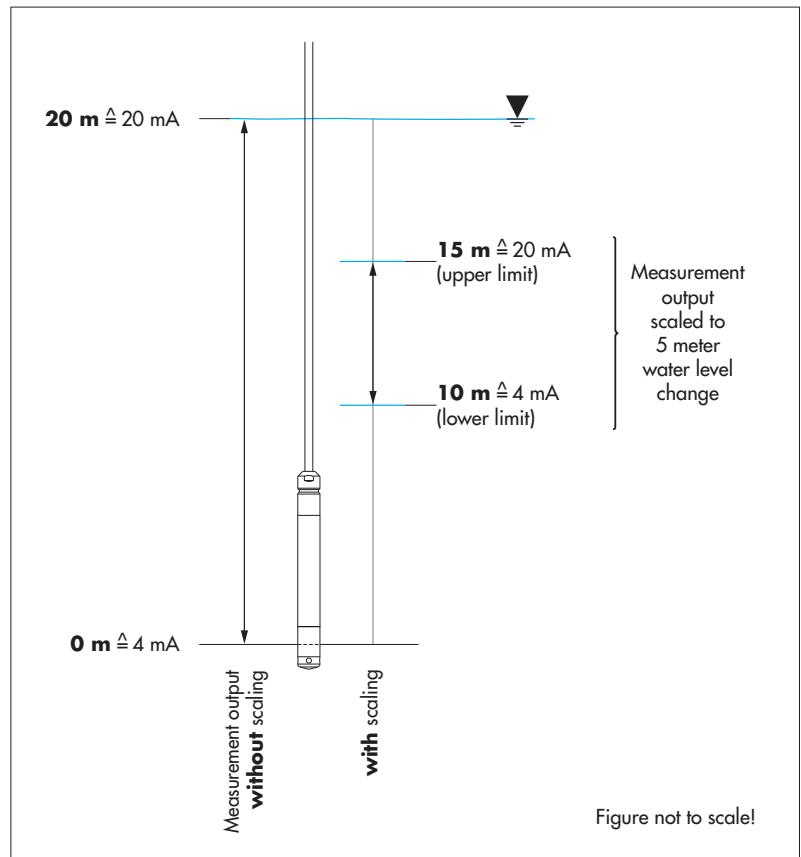

7 Carrying out maintenance work

The high-quality design of the OTT PLS makes regular cleaning work unnecessary. Even a thin build-up of deposits on the measuring cell will not appreciably affect the measurement results.

If very heavy contamination occurs at the station due to algae, mud, vegetation or sediment, the pressure probe should be checked from time to time. For example, imprecise or implausible measured values may indicate a *blocked* measuring cell. If necessary, the pressure probe can be cleaned easily.

How to clean the pressure probe

- Uninstall OTT PLS (see Chapter 5).
- Remove the black protective cap.
- Clean the measuring cell carefully using a brush (hard bristles). Lime scale deposits can be removed using a common household scale remover. Make sure to follow the use and safety instructions of the scale remover!
- Rinse the pressure probe **thoroughly** with clear water!
- Reattach the black protective cap.
- Reinstall OTT PLS (see Chapter 5).
- Specifying measured values, comparing with a reference value (staff gauge, contact gauge) and correcting as necessary (enter reference or offset value or via scaling function of the datalogger attached).

Fig. 8: Cleaning the pressure probe.

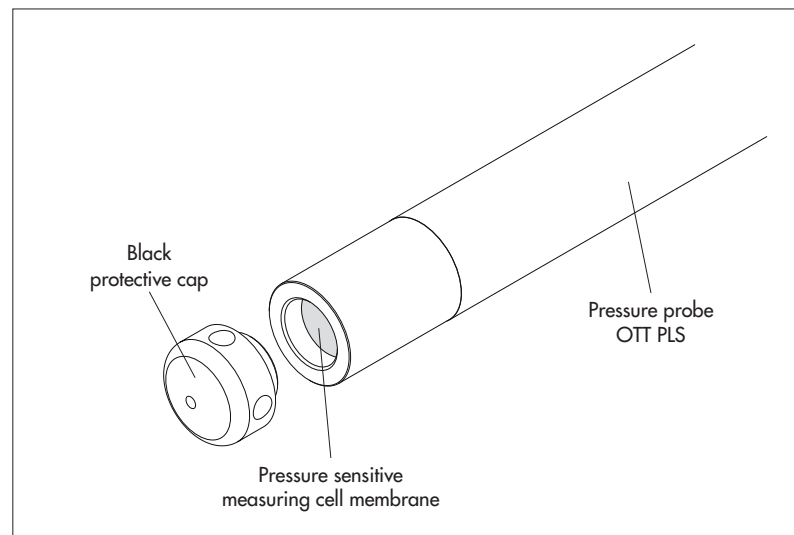

8 Searching for disruptions/troubleshooting

Sensor does not respond to the SDI-12 interface

- ▶ Sensor correctly connected to a datalogger with SDI-12 input (master)?
→ Correct connection assignment.
- ▶ Polarity of the supply voltage reversed?
→ Correct connection assignment.
- ▶ Supply voltage < 9.6 V or > 28 V?
→ Adjust level of voltage supplied (check the length and cross-section of the connection cable).
- ▶ Is the supply voltage not direct current?
→ Only operate sensor with direct current.
- ▶ Does the sensor address of the OTT PLS correspond with the sensor address that the datalogger uses?
→ Correct sensor address.

4 ... 20 mA loop current is missing

- ▶ Is the sensor correctly connected to a datalogger or peripheral device with 4 ... 20 mA input (check polarity)?
→ Correct connection assignment.
- ▶ Is the 4 .. 20 mA loop current correctly supplied through datalogger or OTT PLS (internal/external supply)?
→ Correct connection assignment.

Measured value varies or is not present

- ▶ Sensor dirty?
→ Clean sensor carefully. See Chapter 7, *Carrying out maintenance work*.
- ▶ Installation of the sensor steady (e.g. movement from swell)?
→ Optimize installation.
- ▶ Drops of water in the pressure compensation capillary?
→ Replace pressure probe.

Status output at the 4 ... 20 mA interface

The OTT PLS with 4 ... 20 mA interface indicates the operational state or any faults that might occur via the loop current:

Loop current	Status
4 ... 20 mA	correct
3.4 mA	FLASH memory defective
3.3 mA	Watchdog error
3.2 mA	Failed memory
3.1 mA	Pressure cell defective
3.0 mA	Analog converter defective
<3.0 mA	Loop current error: broken line, loop supply missing
3.6 mA	Measurement range not reached (underflow) or global error
3.8 ... <4.0 mA	Marginally below measurement range: The pressure probe delivers an output signal proportional to the water level, but is outside the specification (under range)
>20.0 ... 20.5 mA	Marginally above measurement range: The pressure probe delivers an output signal proportional to the water level, but is outside the specification (over range)
21.0 mA	Measuring range exceeded (overflow)

Status output at the SDI-12 interface

see SDI-12 command **aM1**!

9 Repair

- With a problem with the device, use Chapter 8, *Error messages/error correction* to see if you can resolve the problem yourself.
- In the case of device defects, please contact the repair center of OTT:

OTT MESSTECHNIK GmbH & Co. KG
Repaircenter
Ludwigstrasse 16
87437 Kempten · Germany
Telephone +49 (0)831/5617-433
Fax +49 (0)831/5617-439
repair@ott.com

Caution: Only have a defective OTT PLS checked and repaired by the OTT repair center. Under no circumstances carry out any repairs yourself. Any repairs or attempted repairs carried out by the customer will result in the loss of any guarantee rights.

10 Note about the disposal of old units



Within the member countries of the European Union

In accordance with the European Union guideline 2002/96/EC, OTT takes back old devices within the member countries of the European Union and disposes of them in an appropriate way. The devices concerned by this are marked with the symbol shown here.

- For further information on the return procedure, please contact your local sales contact. You will find the addresses of all sales partners in the internet on "www.ott.com". Please take into consideration also the national implementation of the EU guideline 2002/96/EC of your country.

For all other countries

- Dispose of the OTT PLS properly after taking out of service.
- Observe the regulations valid in your country for the disposal of electronic devices.
- Never put the OTT PLS into the normal household waste.

Materials used

See Chapter 11 *Technical data*

11 Technical Data

Water level

Measuring range	0 ... 4 m water column (0 ... 0.4 bar) 0 ... 10 m water column (0 ... 1 bar) 0 ... 20 m water column (0 ... 2 bar) 0 ... 40 m water column (0 ... 4 bar)
Resolution	0.001 m; 0.1 cm; 0.01 ft; 0.1 mbar; 0.001 psi
Accuracy (linearity + hysteresis)	
SDI-12 interface	≤ ± 0.05 % of full scale
4 ... 20 mA interface	≤ ± 0.1 % of full scale; 10 ppm/°C at 20 °C
Long-term stability (linearity + hysteresis)	≤ ± 0.1 %/a of full scale
Zero point drift	≤ ± 0.1 % of full scale
Units	m, cm, ft, mbar, psi
Overload protection for the measuring cell	5-times measuring range without permanent mechanical damage
Pressure sensor	ceramic, capacitive; temperature-compensated
Temperature-compensated operating range	-5 °C ... +45 °C

Temperature

Measuring range	-25 °C ... +70 °C
Resolution	0.1 °K
Accuracy	± 0.5 °K
Units	°C, °F
Temperature sensor	NTC
Supply voltage	+9,6 ... +28 V DC, typically 12/24 V DC
Current consumption	
SDI-12 sleep mode	< 600 µA
SDI-12 active mode	< 3.6 mA
Interfaces	SDI-12 version 1.3 RS-485 (SDI-12 protocol) 4 ... 20 mA; 2-wire (scaleable)
Reaction times	
Boot time	5,000 ms
Measuring time	< 2,000 ms
Storage temperature	-40 °C ... +85 °C

Mechanical Data

Dimensions

Pressure probe L x Ø	195 mm x 22 mm
System length (cable length included Pressure probe)	1 ... 200 m ±0.5 % ± 0.05 m

Weight

pressure probe	approx. 0.3 kg
----------------	----------------

Material

Pressure probe housing	POM, stainless steel 1.4539 (904 L), resistant to sea water
Cable jacket	PUR
Seals	Viton
Separating membrane	ceramic Al ₂ O ₃ ; 96 %
Type of protection	IP 68

max. immersion depth: 50 meter; probe with 0 ... 4 m measuring range: 20 meter
max. submersion duration: unlimited time

EMC limits

- Resistance to electrostatic discharge (ESD)	complies with EN 61000-4-2 (4 kV contact discharge)
- Resistance to electromagnetic fields	complies with EN 61000-4-3 (10 V/m)
- Resistance to transient disturbances (burst)	complies with EN 61000-4-4 (2 kV)
- Resistance to lightning surge voltages (surge)	complies with EN 61000-4-5 (1 kV)
- Resistance to HF, asymmetric	complies with EN 61000-4-6 (10 V)
- Interference	complies with EN 61000-6-3 Class B

Appendix A – Installing the FAD 4PF humidity absorbing system

The FAD 4PF humidity absorbing system dries the surrounding air that enters the pressure compensation capillary.

- Mount the humidity absorbing system at the driest position possible (e.g. with double-sided tape). If this is in a control cabinet, it is important that there is a pressure compensation possibility to the outside (no hermetically sealed closure!).
- Insert the pressure compensation capillary at least 5 cm into the PVC tube of the humidity absorbing system as shown in Figure 9.

Fig. 9: Installing the FAD4 humidity absorbing system.

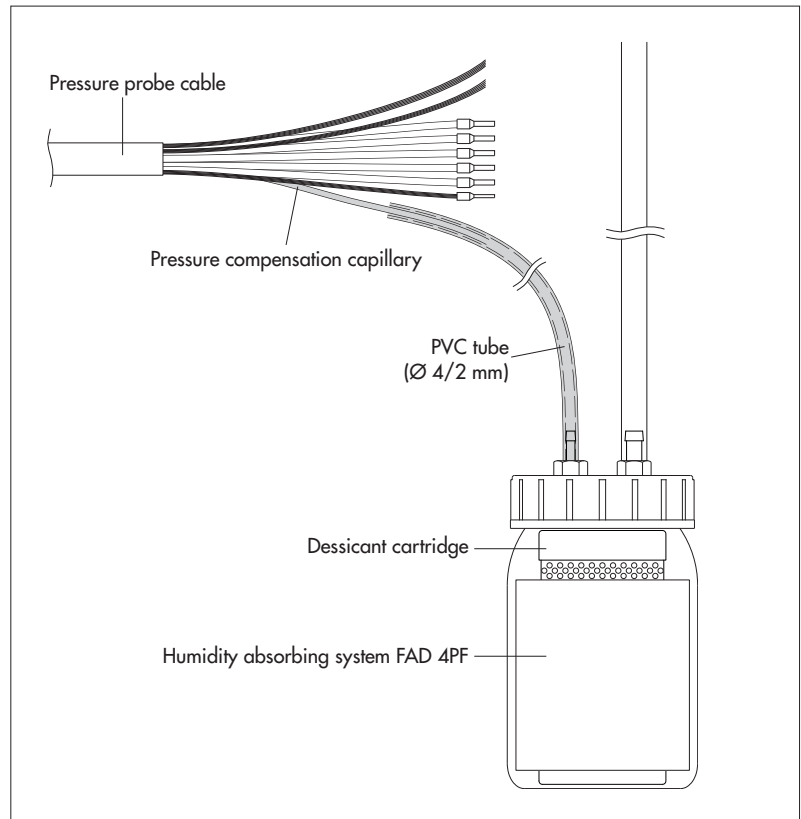

- Please note the instruction leaflet enclosed with the FAD 4PF for regenerating the desiccant cartridge.

Appendix B – Connecting the OTT PLS via SDI-12 or RS-485 interface to LogoSens 2 or DuoSens

Method A: Connecting the OTT PLS via the SDI-12 interface (protocol and physical interface: SDI-12). The maximum length of the cable is 65 m.

- Connect the OTT PLS to the LogoSens 2 Station Manager or to the DuoSens Compact Datalogger as shown in Figure 10. Take note of the operating instructions for the LogoSens 2/DuoSens.

Fig. 10: Connecting the OTT PLS to a LogoSens 2 or DuoSens using an SDI-12 interface.

The letters above the screw terminal strip identify the possible connections on the LogoSens 2/DuoSens.

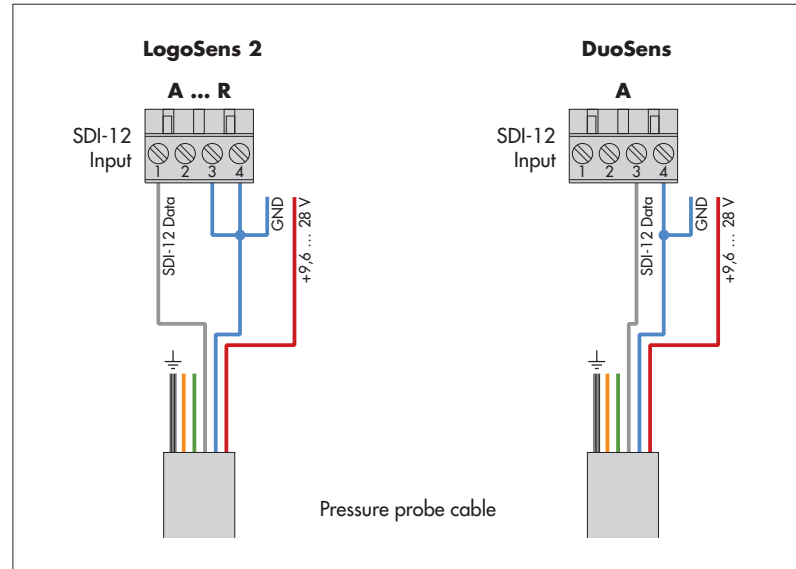

Method B: Connect OTT PLS using the physical RS-485 interface (SDI-12 protocol via physical RS-485 interface). The maximum length of the cable is 1,000 m.

- Connect the OTT PLS to the LogoSens 2 Station Manager or to the DuoSens Compact Datalogger as shown in Figure 11. Take note of the operating instructions for the LogoSens 2/DuoSens.

Fig. 11: Connecting the OTT PLS to a LogoSens 2 or DuoSens using an RS-485 interface (SDI-12 protocol).

The letters above the screw terminal strip identify the possible connections on the LogoSens 2/DuoSens.

When connecting the OTT PLS to the LogoSens 2, use a 120 Ohm terminator (order number: 96.300.205.9.5).

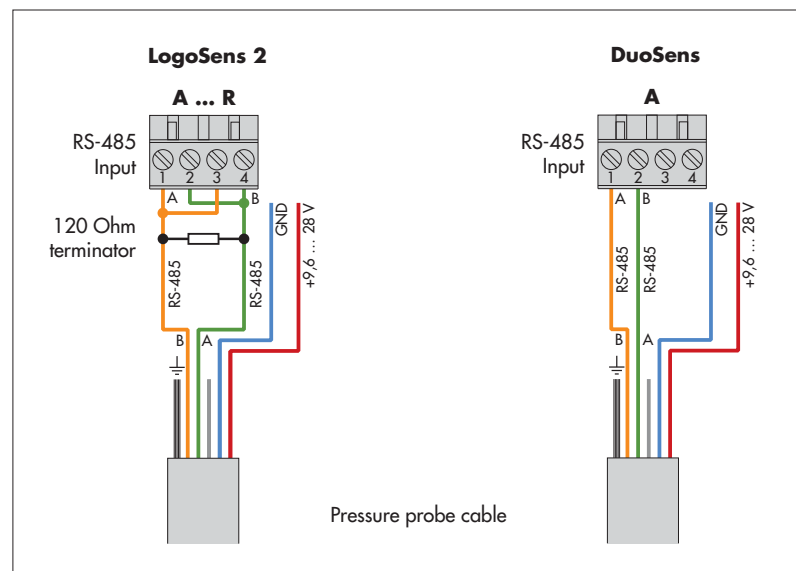

- To achieve better protection against overloads, you can optionally connect the cable shielding to a grounding point/equipotential busbar.

Configuring the LogoSens 2/DuoSens for the OTT PLS with SDI-12 interface

- Create a LogoSens 2/DuoSens channel with *SDI-12 Master* or *OTT SDI RS485* function block (*Serial sensors* tab).
- Apply the following settings:

Fig. 12: Setting the operating parameters of the LogoSens 2/DuoSens *SDI-12 Master* function block.

The function block *OTT SDI RS485* is set in the same way.

- ▶ Terminal block
LogoSens 2: A ... R
DuoSens *SDI-12 Master*: A 3-4 (specified)
DuoSens *OTT SDI RS485*: A 1-2 (specified)
Terminal block used (screw terminal strip) of the LogoSens 2/DuoSens.
- ▶ Slave address
SDI-12 bus address. Each slave address may only be allocated once to an SDI-12 bus feed. (Checking/setting: see operating instructions LogoSens 2/DuoSens, Chapter *SDI-12 transparent mode*.)
Typical setting: 0 (only one OTT PLS is connected to the terminal block with no bus operation).
- ▶ Value no.
Identifies which value (water level or temperature) the OTT PLS is recording on this channel. Typical setting: 1 (water level)
- ▶ Measurement mode
M! (water level + temperature). If the status is also to be recorded: additional channel with *M!* necessary.
- ▶ Value no./
Virtual terminal ID
Allocation of the additional value of the OTT PLS to the virtual terminal (only with *M!*) (Temperature; see also Chapter 6.1; command *aM!*).
- In the appropriate *Channel* function blocks, adjust the required units and number of digits after the decimal place (m: 3; cm: 0; ft: 2; °C: 1, °F: 1, mbar: 1, psi: 3, Status: 0).

Notes:

- ▶ For recording both measured values two channels in the LogoSens 2/DuoSens are thus necessary. The first channel contains the function block *SDI-12 Master* or *OTT SDI RS485* as the input signal. The other channel contains a function block *Virtual Sensor (V02)* as the input signal. Naturally it is possible to record only one value. In this case, no entry is required in the *Value no./Virtual terminal ID* field. If the status is also to be recorded, an additional channel with function block *SDI-12 master* or *OTT SDI RS485* and measurement mode *M!* is necessary.
- ▶ Further information on the SDI-12 commands and responses used can be found in Chapter 6, *SDI-12 Commands and Responses*.
- ▶ The OTT PLS makes the measurement results available 2 seconds after the SDI-12 command *aM!*.

Appendix C – Connecting the OTT PLS to a LogoSens 2 or DuoSens using a 4 ... 20 mA interface

- Connect the OTT PLS to the LogoSens 2 Station Manager or to the DuoSens Compact Datalogger as shown in Figures 13 and 14. Take note of the operating instructions for the LogoSens 2/DuoSens.
Maximum cable length: dependent on the level of the supply voltage and size of the burden (load resistor). Ensure that the ohmic resistance of the connection cable together with any burden present does not exceed the maximum permitted load resistance (see Chapter 5.7). The upper limit for the cable length is 1,000 m in all cases.

Fig. 13: Connecting the OTT PLS to the LogoSens 2 using a 4 ... 20 mA interface.

Use the 100 Ohm OTT burden (order number: 55.550.126.4.2)!

The letters above the screw terminal strip identify the possible connections on the LogoSens 2.

The supply for the loop current and the supply of the OTT PLS is made, in the application example shown, directly from the OTT LogoSens 2.

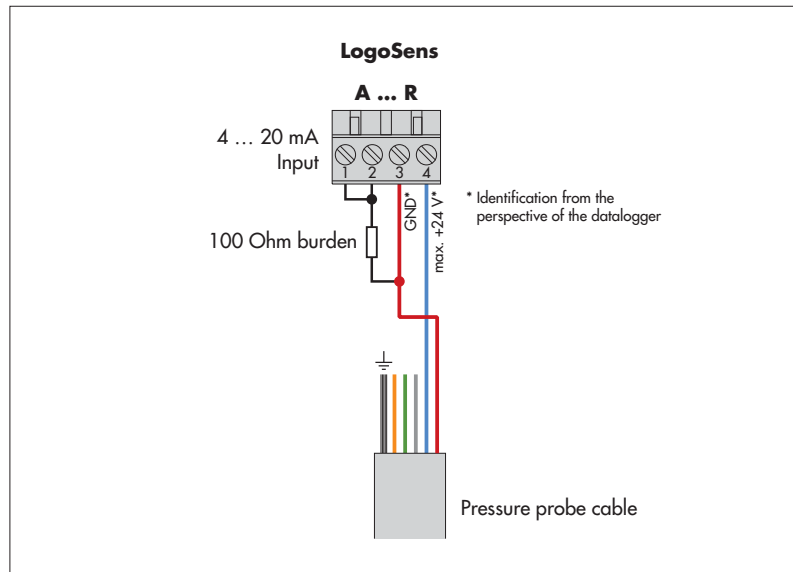
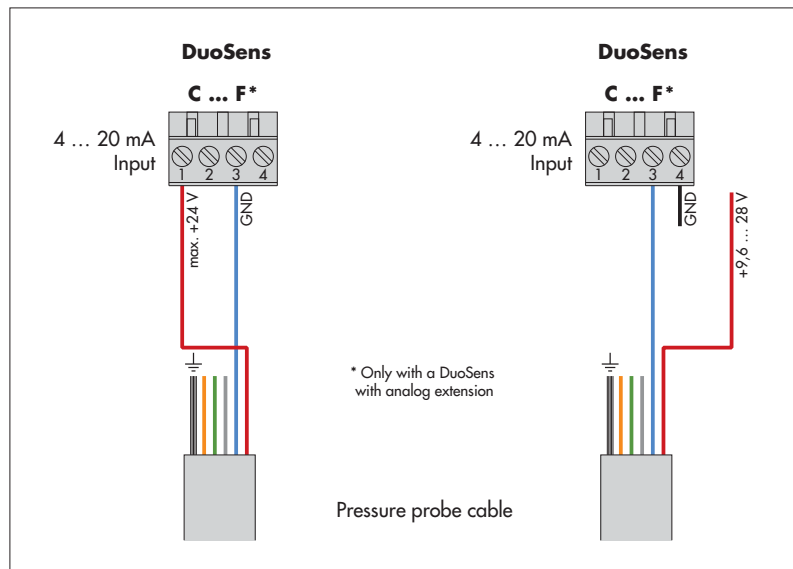

Fig. 14: Connecting the OTT PLS to a DuoSens using a 4 ... 20 mA interface.

The letters above the screw terminal strip identify the possible connections on the DuoSens.

The supply for the current loop and the supply of the OTT PLS is made in the application example shown on the left directly from the OTT DuoSens.



- To achieve better protection against overload, you can optionally attach the cable shielding to a ground point/potential equalization panel.

Configuring LogoSens 2/DuoSens for OTT PLS with 4 ... 20 mA interface

- Create a LogoSens 2/DuoSens channel with function block *I 4-20 mA* (LogoSens 2) or *U/I/Pt100/...* (DuoSens) (Analog sensors tab).
- Apply the following settings:

Fig. 15: Setting operating parameters of the LogoSens 2 *I 4-20 mA* function block.

The DuoSens function block *U/I/Pt100/...* is set in the same way.

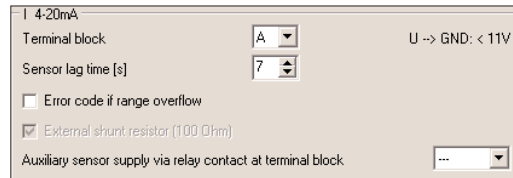

- ▶ Terminal block
 - LogoSens 2: A ... R
 - DuoSens: C ... F
 - Terminal block used (screw terminal strip) of the LogoSens 2/DuoSens.
 - Set to *I 4-20 mA ext.*
- ▶ Measurement mode (only with DuoSens)
- ▶ Sensor lag time (s)
 - switches on the LogoSens 2/DuoSens input 7 seconds before the actual measurement process
- ▶ Error code if range overflow
 - If required: record error codes on range overflow
- ▶ Auxiliary sensor supply via relay contact at terminal block (only for LogoSens 2)
 - not required with an OTT PLS
- Insert a *2-point scaling* function block into this channel and set the appropriate water level values for the electrical values measured (e.g. Point 1: 4 → 0; Point 2: 20 → 40) With this function it is possible to reference a level zero at the same time.
- In the *Channel* function block, set the required units and number of digits after the decimal place (m: 3; cm: 0; ft: 2; °C: 1, °F: 1, mbar: 3, psi: 1, Status: 0).

Note on Appendices B and C

To reference OTT PLS measured values to a level zero: Enter the contact gauge/staff gauge measurement, for example using the scaling function of the datalogger connected to the OTT PLS (e.g. LogoSens 2/DuoSens).

Example:

$$y = ax + b \quad \begin{array}{l} a = 1 \text{ for level measurement and } -1 \text{ for depth measurement} \\ b = \text{reference or offset value} \end{array}$$

Alternatively with SDI-12/RS-485 interface: set a reference value or offset value using the SDI-12 transparent mode of a datalogger when starting up.



**Konformitätserklärung
Declaration of Conformity
Declaration de Conformité**

Wir/ We/ Nous
Anschrift/ Address/ Adresse

OTT Messtechnik GmbH & Co. KG
Ludwigstraße 16
D-87437 Kempten

erklären, daß das Produkt/ declare, that the product/ déclarons, que le produit

Bezeichnung/ Name/ Nom

OTT PLS

Artikel- Nr./ Article No./ No. d' Article

63.037.001.9.0XX

mit den Anforderungen der Normen/ fulfills the requirements of the standard/ satisfait aux exigences des normes

EG (2004/108/EG):

national:

international:

EN 61000-6-3

IEC 61000-6-3

Störaussendung/ emission/ émission

Klasse/ class/ classe B

class/ classe B

Störfestigkeit/ noise immunity/ immunité

EN 61000-6-2

IEC 61000-6-2

EN 61000-4-2 (4 kV/8 kV)

IEC 61000-4-2 (4 kV/8 kV)

EN 61000-4-3 (10 V/m)

IEC 61000-4-3 (10 V/m)

EN 61000-4-4 (2 kV)

IEC 61000-4-4 (2 kV)

EN 61000-4-5 (1 kV)

IEC 61000-4-5 (1 kV)

EN 61000-4-6 (10 V)

IEC 61000-4-6 (10 V)

und den hinterlegten Prüfberichten übereinstimmt und damit den Bestimmungen entspricht/
and the taken test reports and therefore corresponds to the regulations of the Directive/
et les rapports d'essais notifiés et, ainsi, correspond aux réglement de la Directive.

Ort und Datum der Ausstellung/

Kempten, den 2008-07-28

Place and Date of Issue/

Lieu et date d' établissement

Name und Unterschrift des Befugten/

Name and Signature of authorized person/

Nom et signature de la personne autorisée

i.v. Peter Fend

Peter Fend
(Director R&D)

OTT MESSTECHNIK GmbH & Co. KG
Postfach 21 40 · 87411 Kempten
Ludwigstraße 16 · 87437 Kempten
Tel.: +49(0)831/5617-0
Fax: +49(0)831/5617-209
info@ott.com
www.ott.com

Geschäftsführer: Dr.-Ing. Anton Felder · Persönlich haftende Gesellschafterin: **OTT MESSTECHNIK** Verwaltungs GmbH
Sitz der Ges.: Kempten · Registergericht Kempten HRB 7687 und HRA 3807 · USt.-ID.-Nr. DE 128780710 · Steuer-Nr. 127/171/51206
WEEE-Registrierungs-Nummer: 49590817

Deutsche Bank AG München · BLZ 700 700 10 · Kto. Nr. 409 0304 00 · BIC: DEUTDE33 · IBAN: DE98 7007 0010 0409 0304 00

Es gelten unsere Allgemeinen Geschäftsbedingungen (siehe „www.ott.com/AGB“)

All business transactions shall be subject to our General Terms and Conditions (see "www.ott.com/GTC")

Appendix E

CR1000 Wiring Options for the PLS

```
' Option 1: Wire PLS Sensor to Datalogger via the OT6000 (FAD5).
'           Requires the use of the FIN3COND-L between the OT6000 and
'           the CR1000. Use the OT6000 wire connectors to connect the
'           PLS cable to the FIN3COND-L cable.

' PLS +12V Red - (FIN3COND-L Red) - CR1000 12V
' PLS GND Blue - (FIN3COND-L Black) - CR1000 G
' PLS SDI-12 Data Grey - (FIN3COND-L White) - CR1000 C1
' PLS Shield Clear - (FIN3COND-L Clear) - CR1000 G

' Option 2: Wire PLS Sensor directly to the CR1000 Datalogger.

' PLS +12V Red - CR1000 12V
' PLS GND Blue - CR1000 G
' PLS SDI-12 Data Grey - CR1000 C1
' PLS Shield Clear - CR1000 G

'*****

'Declare Public Variables
Public PLS_Results(2)
Public Trigger_Measurement As Boolean
Public Site_Offset

'Declare Alias' for PLS measurement
Alias PLS_Results(1) = Water_Level_m
Alias PLS_Results(2) = Water_Temp_C

'Declare Units for PLS Outputs
Units Water_Level_m = meters
Units Water_Temp_C = degrees Celsius
Units Site_Offset = meters

'Define Data Tables
DataTable(Table1,True,-1)
  DataInterval(0,15,Min,10)
  Sample(1,Water_Level_m,FP2)
  Sample(1,Water_Temp_C,FP2)
EndTable

'Main Program
BeginProg

'Enter site specific offset into public variable so that it can be used in the
'calculation of Water Level. This feature cannot be used in this program if the
'output is a pressure value.
Site_Offset = 0.000

Scan(5,Sec,1,0)

'Measure the PLS on a 15 minute interval using the OM! SDI-12 command. The
'measurement can also be manually triggered with the "Trigger Measurement" flag.
'The measurement interval of the PLS can be altered. Please be sure that the
related
'data table reflects the measurement interval.
If TimeIntoInterval (0,15,Min) OR Trigger_Measurement = True Then
  SDI12Recorder(PLS_Results(),1,"0","M!",1,0) 'Other Port options include C3, C5,
and C7
  Trigger_Measurement = False
```

```
'Use site specific Offset to calculate water level. Note that this value can also
be
'added directly to the PLS. If this is done then do not use the site specific
offset
'in this calculation.
Water_Level_m = Water_Level_m + Site_Offset
EndIf

'Call Data Tables and Store Data
CallTable(Table1)
NextScan
EndProg
```

Document number
63.037.001.B.E 01-0708

OTT MESSTECHNIK GmbH & Co. KG

Ludwigstrasse 16
87437 Kempten · Germany
Tel. +49 (0)831 56 17-0
Fax +49 (0)831 56 17-209

info@ott.com
www.ott.com