

INSTRUCTION MANUAL



NR-LITE2 Net Radiometer

9/10



Copyright © 1998-2010
Campbell Scientific, Inc.

WARRANTY AND ASSISTANCE

This equipment is warranted by CAMPBELL SCIENTIFIC (CANADA) CORP. ("CSC") to be free from defects in materials and workmanship under normal use and service for **twelve (12) months** from date of shipment unless specified otherwise. ***** **Batteries are not warranted.** ***** CSC's obligation under this warranty is limited to repairing or replacing (at CSC's option) defective products. The customer shall assume all costs of removing, reinstalling, and shipping defective products to CSC. CSC will return such products by surface carrier prepaid. This warranty shall not apply to any CSC products which have been subjected to modification, misuse, neglect, accidents of nature, or shipping damage. This warranty is in lieu of all other warranties, expressed or implied, including warranties of merchantability or fitness for a particular purpose. CSC is not liable for special, indirect, incidental, or consequential damages.

Products may not be returned without prior authorization. To obtain a Return Merchandise Authorization (RMA), contact CAMPBELL SCIENTIFIC (CANADA) CORP., at (780) 454-2505. An RMA number will be issued in order to facilitate Repair Personnel in identifying an instrument upon arrival. Please write this number clearly on the outside of the shipping container. Include description of symptoms and all pertinent details.

CAMPBELL SCIENTIFIC (CANADA) CORP. does not accept collect calls.

Non-warranty products returned for repair should be accompanied by a purchase order to cover repair costs.



CAMPBELL[®]
SCIENTIFIC

Campbell Scientific (Canada) Corp.
11564 149 Street | Edmonton AB T5M 1W7
780.454.2505 | fax 780.454.2655 | campbellsci.ca

PLEASE READ FIRST

About this manual

Please note that this manual was originally produced by Campbell Scientific Inc. (CSI) primarily for the US market. Some spellings, weights and measures may reflect this origin.

Some useful conversion factors:

Area:	1 in ² (square inch) = 645 mm ²
Length:	1 in. (inch) = 25.4 mm
	1 ft (foot) = 304.8 mm
	1 yard = 0.914 m
	1 mile = 1.609 km
Mass:	1 oz. (ounce) = 28.35 g
	1 lb (pound weight) = 0.454 kg
Pressure:	1 psi (lb/in ²) = 68.95 mb
Volume:	1 US gallon = 3.785 litres

In addition, part ordering numbers may vary. For example, the CABLE5CBL is a CSI part number and known as a FIN5COND at Campbell Scientific Canada (CSC). CSC Technical Support will be pleased to assist with any questions.

About sensor wiring

Please note that certain sensor configurations may require a user supplied jumper wire. It is recommended to review the sensor configuration requirements for your application and supply the jumper wire is necessary.

NR-LITE2 Table of Contents

PDF viewers note: These page numbers refer to the printed version of this document. Use the Adobe Acrobat® bookmarks tab for links to specific sections.

1. General Description	1
1.1 Electrical Properties.....	2
1.2 Spectral Properties.....	2
1.3 Directional/Cosine Response.....	3
1.4 Sensitivity to Wind Speed	4
2. Sensor Specifications	5
3. Installing the NR-LITE2	6
4. Wiring	8
5. Datalogger Programming	9
5.1 Input Range and Integration	9
5.2 Calibration Factor	9
5.3 Example Programs.....	10
5.3.1 CR3000 Example Program without Wind Speed Correction	10
5.3.2 CR1000 Example Program with Wind Speed Correction.....	11
5.3.3 CR10(X) Example Program without Wind Speed Correction	12
5.3.4 CR10X Example Program with Wind Speed Correction.....	13
6. Maintenance	15
7. Troubleshooting	15
7.1 Checking Sensor Operation	15
7.2 Radiometer produces no apparent output	16
7.3 Readings are not as expected.....	16

Figures

1. NR-LITE2's Components and Dimensions (in millimeters).....	1
2. Electrical Circuit for the NR-LITE2 Net Radiometer.....	2
3. Approximate Spectral Sensitivity and Solar/F.I.R. Radiation	3
4. Cosine Response of a Typical Net Radiometer	4
5. NR-LITE2 Wind Sensitivity.....	5
6. Mounting the NR-LITE2 onto a pole (top) and crossarm (bottom) via the 26120 Mounting Kit.....	7
7. NR-LITE2 to Datalogger Connections.....	8

Tables

- 1. Datalogger Connections for Differential Measurement..... 8
- 2. Datalogger Connections for Single-Ended Measurement..... 8

NR-LITE2 Net Radiometer

The NR-LITE2 is a high-output thermopile sensor which measures the algebraic sum of incoming and outgoing all-wave radiation (i.e. both short-wave and long-wave components). Incoming radiation consists of direct (beam) and diffuse solar radiation plus long-wave irradiance from the sky. Outgoing radiation consists of reflected solar radiation plus the terrestrial long-wave component.

The NR-LITE2 is equipped with Teflon-coated sensor surfaces. This results in a robust design which gives very easy maintenance and good sensor stability. However, this design is slightly less accurate than the more traditional radiometers which use plastic domes.

1. General Description

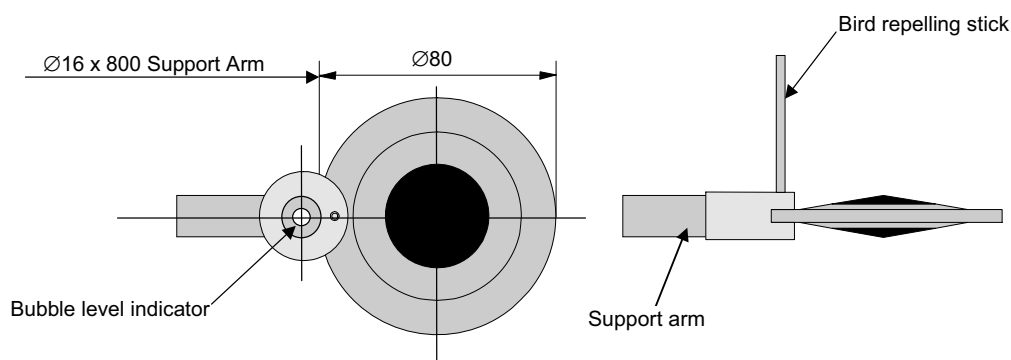

FIGURE 1. NR-LITE2's Components and Dimensions (in millimeters)

The NR-LITE2 is used for measuring solar and far infrared radiation balance. This balance is known as the net (total) radiation. Its upwards facing sensor measures the solar energy and far infra-red energy that is received from the entire hemisphere (180° field of view). Its downwards facing sensor measures the energy received from the surface of the soil. The two readings are automatically subtracted and the result converted to a single output signal. This output represents the net radiation, (which can be interpreted as meaning the radiative energy that is seen at the surface) and is expressed in Watts per square meter (W m^{-2}).

The NR-LITE2 is designed for continuous outside use. The sensor surfaces are coated with Teflon. This ensures good sensor stability, very long life and easy maintenance compared to the more usual radiometers fitted with plastic domes. However, it does have some disadvantages, particularly a higher sensitivity to wind speed with a subsequent lessening of accuracy. It is, though, possible to correct for the wind speed sensitivity if the sensor is installed in a system where wind speed is also being measured.

Although net radiometers are usually used in meteorology to measure radiation balance, the NR-LITE2 can also be used to measure indoor climate radiative stress.

1.1 Electrical Properties

The thermopile consists of a number of thermocouples connected in series, essentially providing a highly sensitive differential temperature sensor. The thermopile generates a voltage output – the sensor itself is passive, and so no power supply is required.

The upwards and downwards facing sensor surfaces are connected to the upper and lower thermopile junctions respectively, and so the sensor can measure the differential temperature. This temperature differential can be measured to a high accuracy (in the order of 0.001 degrees), and is proportional to the net radiation.

The thermopile determines the electrical characteristics of the instrument. Both upper and lower facing sensors have a field of view of 180 degrees, and their angular characteristics conform closely to the so-called ‘cosine’ response (see following sections).

The electrical sensitivity for the thermopile changes with temperature, and no nominal sensitivity value is available.

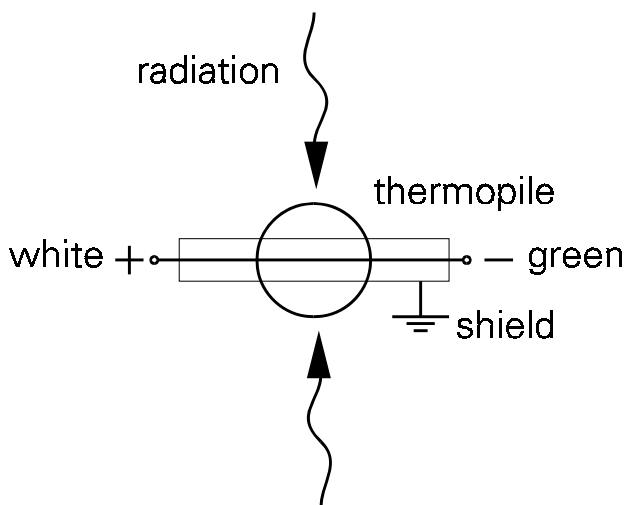

FIGURE 2. Electrical Circuit for the NR-LITE2 Net Radiometer

1.2 Spectral Properties

The spectral properties of the NR-LITE2 are determined by the Teflon surface of the sensors. An approximate spectral sensitivity response curve for the instrument combined with the spectrum of the sun under a clear sky, and the spectrum of outgoing far infra-red radiation (F.I.R.) is shown in Figure 3, below.

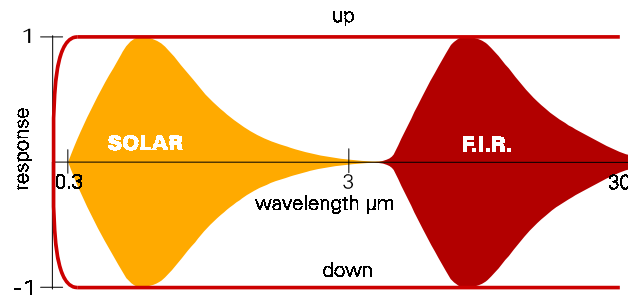

FIGURE 3. Approximate Spectral Sensitivity and Solar/F.I.R. Radiation

The upwards facing sensor is calibrated for solar radiation wavelengths. The following assumptions are made:

- It is assumed that the downwards facing sensor has the same sensitivity. However, since the two sensors may not be perfectly symmetrical, this assumption may not always be true, but any differences are small.
- It is also assumed that the NR-LITE2's sensitivity is the same for both solar and infrared radiation.

1.3 Directional/Cosine Response

The measurement of the radiation falling on a surface (also known as irradiance or radiative flux) is based on two assumptions:

1. The sensor surface is spectrally black - i.e. that it absorbs all radiation from all wavelengths (see section above).
2. That it has a true field of view of 180°.

These two properties, taken together, with which the net radiometer needs to comply, are generally known as the 'cosine response'.

A perfect cosine response will show maximum sensitivity at an angle of incidence of zero degrees (perpendicular to the sensor surface) and zero sensitivity at an angle of incidence of 90 degrees (radiation passing over the sensor surface). At any angle between 0 and 90 degrees the sensitivity should be proportional to the cosine of the angle of incidence.

Figure 4 shows the behavior of a typical net radiometer. The vertical axis shows the deviation from ideal behavior, expressed in percentage deviation from the ideal value.



FIGURE 4. Cosine Response of a Typical Net Radiometer

1.4 Sensitivity to Wind Speed

The calibration of the NR-LITE2 is carried out at zero wind speed. At any other wind speed the sensitivity will decrease. It has been shown that this decrease in sensitivity is less than 1% of reading per meter per second wind speed, and the effect is essentially independent of the radiation level.

Net radiation readings can be corrected for wind speed sensitivity using the following equation, which was developed by Jerry Brotzge at the Oklahoma Climate Survey:

Wind Sensitivity equation for the NR-LITE2:

$$\begin{aligned}
 R_{n,cor} &= R_{n,obs} & U < 5 \text{ m/s} \\
 R_{n,cor} &= R_{n,obs} * (1.0 + A * (U - 5.0)) & U > 5 \text{ m/s}
 \end{aligned}$$

Where,

- R_{n,cor} = Net radiation corrected for wind speed
- R_{n,obs} = Net radiation not corrected for wind speed
- U = Horizontal wind speed in m/s
- A = empirical constant derived from data = 0.021286

The following scatter plots illustrate the wind sensitivity for both the NR-LITE2 and CNR1 net radiometer models.

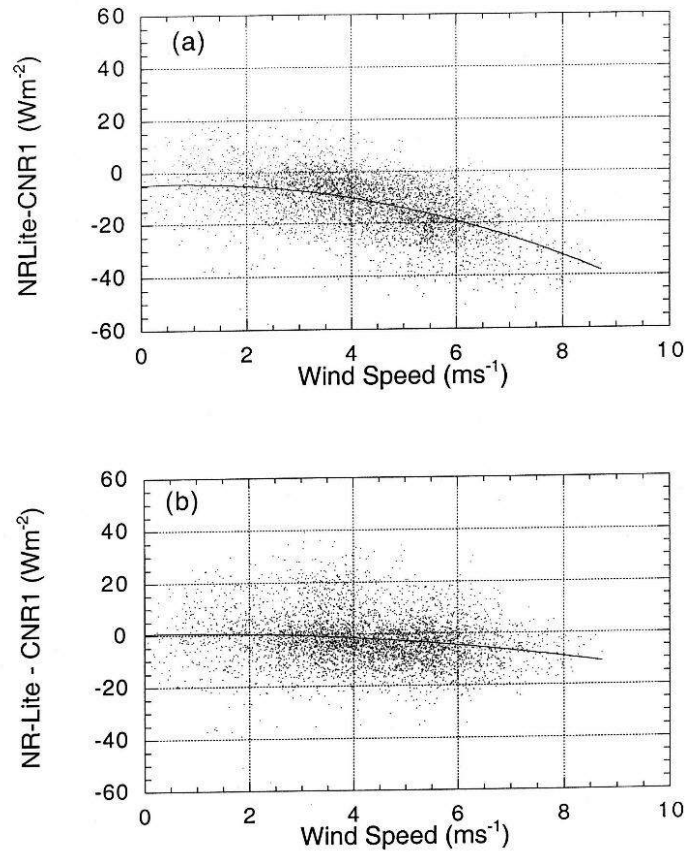

Fig. 10: Differences between the NR-Lite and CNR1 as a function of wind speed for daytime conditions during 7 May - 6 June, 1998. (a) No correction. (b) Eq. (4) applied as a correction.

FIGURE 5. NR-LITE2 Wind Sensitivity

2. Sensor Specifications

Spectral

Spectral range:	0.2 to 100 μm
Detector type:	Thermopile
Detector protection:	Teflon coating
Detector profile:	Conical

Directional

Directional error:	
(0 - 60° at 1000 W m^{-2}):	<30 W m^{-2}
Sensor asymmetry:	$\pm 5\%$ typical, ($\pm 10\%$ worst case).

Mechanical

Housing material:	Anodized aluminum
Cable material:	Polyurethane
Weight:	200 g
Cable length:	15 m (can be extended up to 100 m)
Physical Dimensions	
Sensor:	3.1" (8.0 cm) diameter
Support Arm:	0.6" (1.6 cm) diameter x 31.5" (80 cm) L
Weight:	23 oz (635 g)

Environmental

Working temperature:	-30 to +70°C
Temperature dependence:	0.12%/°C

3. Installing the NR-LITE2

NOTE Screw in the ~2.5" long bird repellent stick, which is typically shipped with the calibration documentation.

Mount the sensor so that no shadow will be cast on it at any time of day from obstructions such as trees, buildings or the mast or structure on which it is mounted. In the northern hemisphere the instrument is normally oriented towards the South to avoid potential problems from shading. The downward facing sensor is representative (99%) for a circular area having a radius of ten times the height (10h).

To avoid shading effects and to promote spatial averaging the NR-LITE2 should be mounted at least 1.5 m above the ground surface. It is recommended that the NR-LITE2 be mounted to a separate vertical pipe at least 25' from any other mounting structures. PN 26120 mounting bracket kit is used to mount the NR-LITE2 directly to a vertical pipe, or to a CM202, CM204, or CM206 crossarm. Mount the sensor as follows:

1. Attach the 26120 mounting bracket to the vertical mounting pipe, or CM200-series crossarm using the u-bolt provided (see Figure 6).
2. Insert the sensor's support arm into the mounting block of the mounting bracket kit. Make sure the sensor points in the direction of the arrows that appear after the word "SENSOR" on top of the bracket (see Figure 6). Perform a coarse leveling of the sensor using the sensor's bubble level. Tighten the four screws on top of the mounting bracket to properly secure the support arm so that it does not rotate.

NOTE Do not attempt to rotate the instrument using the sensor head or you may damage the sensor – use the support arm only.

3. Perform the fine leveling using the two spring-loaded leveling screws— one on the front and the other on the back of the bracket.

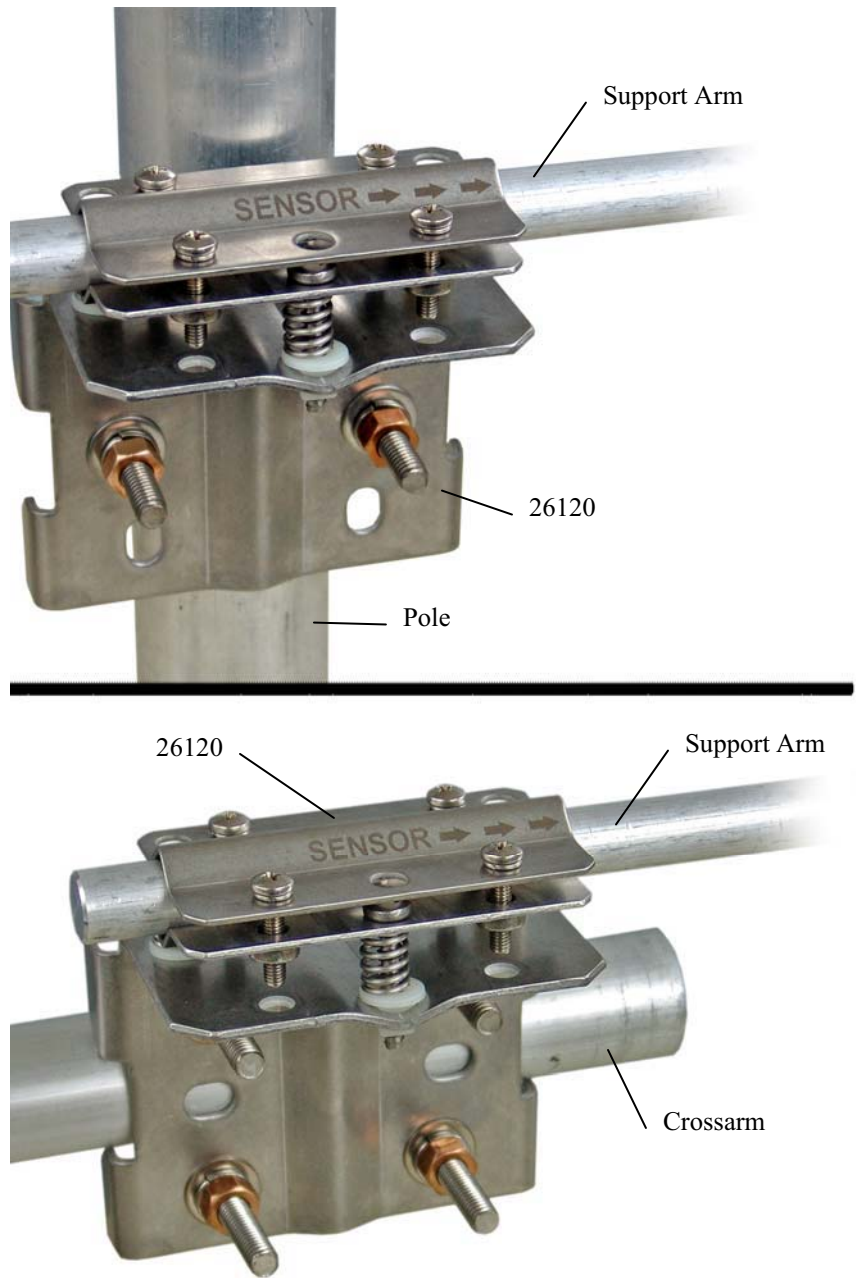

FIGURE 6. Mounting the NR-LITE2 onto a pole (top) and crossarm (bottom) via the 26120 Mounting Kit.

4. Wiring

The NR-LITE2 can be measured with a differential or single-ended channel on the datalogger; a differential channel is recommended.

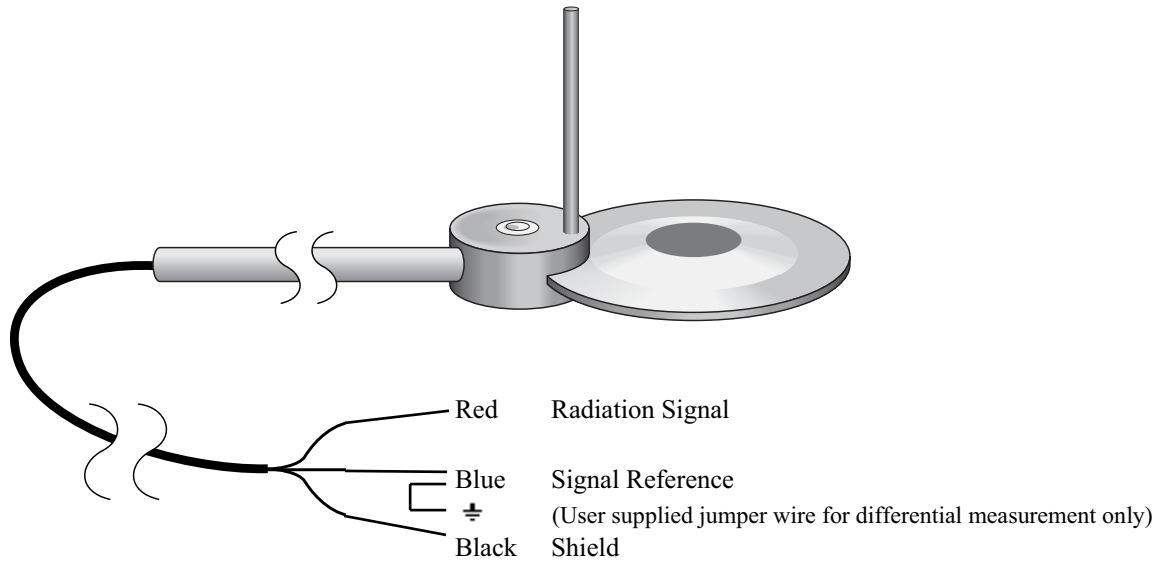

FIGURE 7. NR-LITE2 to Datalogger Connections

TABLE 1. Datalogger Connections for Differential Measurement

Function	Color	CR10X,CR510	CR23X, 21X, CR7	CR800, CR850, CR1000, CR3000, CR5000
Radiation Signal	Red	Differential H	Differential H	Differential H
Signal Reference	Blue	Differential L	Differential L	Differential L
	Jumper to	AG	⚡	⚡
Shield	Black	G	⚡	⚡

TABLE 2. Datalogger Connections for Single-Ended Measurement

Function	Color	CR10X,CR510	CR23X, 21X, CR7	CR800, CR850, CR1000, CR3000, CR5000
Radiation Signal	Red	S.E. Channel	S.E. Channel	S.E. Channel
Signal Reference	Blue	AG	⚡	⚡
Shield	Black	G	⚡	⚡

5. Datalogger Programming

NOTE

This section is for users who write their own datalogger programs. A datalogger program to measure this sensor can be generated using Campbell Scientific's Short Cut Program Builder Software. You only need to read the calibration portion of this section if using Short Cut.

The NR-LITE2 outputs a low-level voltage ranging from 0 to a maximum of about 15 mV. A differential voltage measurement (VoltDiff in CRBasic or Instruction 2 in Edlog) is recommended because it has better noise rejection than a single-ended measurement. If a differential channel is not available, a single-ended measurement (VoltSE in CRBasic or Instruction 1 in Edlog) can be used. The acceptability of a single-ended measurement can be determined by simply comparing the results of single-ended and differential measurements made under the same conditions.

5.1 Input Range and Integration

Normally the 15 mV range for the 21X or CR7, the 25 mV range for the CR800, CR850, CR1000, CR10(X) or CR500/CR510, and the 50 mV range for the CR3000, CR5000, or CR23X are suitable.

The slow or 60 Hz rejection integration gives a more noise-free reading. A fast integration takes less power and allows for faster throughput.

5.2 Calibration Factor

Each NR-LITE2 is provided with a 'Certificate of Calibration' by the manufacturer which shows the sensor serial number and a 'sensitivity' or calibration factor. This calibration factor, after conversion, is used in the datalogger program. Always cross check to ensure that the serial number of your NR-LITE2 and the number on the calibration certificate are identical. The serial number and sensitivity are also shown on a small label attached to the connecting arm near the head of the sensor itself.

The calibration factor provided by Kipp & Zonen is in units of $\mu\text{V}/(\text{W m}^{-2})$, which needs to be converted to units of $(\text{W m}^{-2})/\text{mV}$ for the multiplier parameter in the datalogger program. To convert the units, divide the calibration factor into 1000. For example, if the calibration factor is 15.8 $\mu\text{V}/(\text{W m}^{-2})$, the multiplier is:

$$1000/15.8 = 63.29 (\text{W m}^{-2})/\text{mV}$$

5.3 Example Programs

5.3.1 CR3000 Example Program without Wind Speed Correction

Shown below is an example program written for the CR3000 datalogger. The datalogger measures the output from the sensor every 5 seconds and outputs the average net radiation every hour. The calibration factor used will only apply for one specific sensor. A new value will need to be calculated for every different sensor based on the certificate of calibration for that sensor (see Section 5.2).

Wiring for Example 1

Color	Function	Example CR3000 Program Channels Used
Red	Radiation Signal	IH
Blue	Signal Reference	IL
Jumpered to		\oplus
Black	Shield	\oplus

```
'CR3000

'Declare Variables and Units
Public BattV
Public NR_Wm2

Units BattV=Volts
Units NR_Wm2=W/meter^2

'Define Data Tables
DataTable(Table1,True,-1)
  DataInterval(0,60,Min,10)
  Average(1,NR_Wm2,FP2,False)
EndTable

DataTable(Table2,True,-1)
  DataInterval(0,1440,Min,10)
  Minimum(1,BattV,FP2,False,False)
EndTable

'Main Program
BeginProg
  Scan(5,Sec,1,0)
  'Default Datalogger Battery Voltage measurement BattV
  Battery(BattV)
  'NR-LITE2 Net Radiometer (no wind speed correction) measurement NR_Wm2
  VoltDiff(NR_Wm2,1,mV50,1,True,0,_60Hz,100,0)
  'Call Data Tables and Store Data
  CallTable(Table1)
  CallTable(Table2)
  NextScan
EndProg
```

5.3.2 CR1000 Example Program with Wind Speed Correction

Shown below is an example program written for the CR1000 datalogger. Besides measuring the NR-LITE2, the program also measures wind speed and applies the correction factor as described in Section 1.4. Average net radiation and wind speed are output every hour.

NR-LITE2 wiring for Example 2

Color	Function	Example CR1000 Program Channels Used
Red	Radiation Signal	2H
Blue	Signal Reference	2L
Jumpered to		$\frac{\ominus}{\oplus}$
Black	Shield	$\frac{\ominus}{\oplus}$

```
'CR1000

'Declare Variables and Units
Dim WindCor_7
Public BattV
Public WS_ms
Public WindDir
Public NR_Wm2
Public CNR_Wm2

Units BattV=Volts
Units WS_ms=meters/second
Units WindDir=Degrees
Units NR_Wm2=W/m^2
Units CNR_Wm2=Watts/meter^2

'Define Data Tables
DataTable(Table1,True,-1)
  DataInterval(0,60,Min,10)
  Average(1,WS_ms,FP2,False)
  Sample(1,WindDir,FP2)
  Average(1,NR_Wm2,FP2,False)
  Average(1,CNR_Wm2,FP2,False)
EndTable

DataTable(Table2,True,-1)
  DataInterval(0,1440,Min,10)
  Minimum(1,BattV,FP2,False,False)
EndTable

'Main Program
BeginProg
  Scan(5,Sec,1,0)
  'Default Datalogger Battery Voltage measurement BattV
  Battery(BattV)
```

```
'05103 Wind Speed & Direction Sensor measurements WS_ms and WindDir
PulseCount(WS_ms,1,1,1,1,0.098,0)
BrHalf(WindDir,1,mV2500,1,1,1,2500,True,0,_60Hz,355,0)
If WindDir>=360 Then WindDir=0

'NR-LITE2 Net Radiometer (dynamic wind speed correction)
'measurement NR_Wm2 and CNR_Wm2

VoltDiff(NR_Wm2,1,mv25,2,True,0,_60Hz,100,0)
If WS_ms>=5 Then
    CNR_Wm2=NR_Wm2*(1+0.021286*(WS_ms-5))
Else
    CNR_Wm2=NR_Wm2
EndIf
'Call Data Tables and Store Data
CallTable(Table1)
CallTable(Table2)
NextScan
EndProg
```

5.3.3 CR10(X) Example Program without Wind Speed Correction

Shown below is an example program written for the CR10(X) datalogger. The datalogger measures the output from the sensor every 60 seconds and outputs the average net radiation every hour.

The calibration factor used will only apply for one specific sensor. A new value will need to be calculated for every different sensor based on the certificate of calibration for that sensor (see Section 5.2).

Wiring for Example 3

Color	Function	Example CR10X Program Channels Used
Red	Radiation Signal	1H
Blue	Signal Reference	1L
Jumpered to		AG
Black	Shield	G

```
:{CR10X}
;
;
*Table 1 Program
01: 60      Execution Interval (seconds)
1: Volt (DIFF) (P2)
1: 1      Reps
2: 3**    25 mV Slow Range      ;range code for CR10(X) datalogger
3: 1*    DIFF Channel
4: 1*    Loc [ Net_rad ]
5: 63.29 Mult      ;Multiplier for specific sensor
6: 0.0   Offset      ;in units of (W m-2)/mV (see above)
```

```

2: If time is (P92)
  1: 0      Minutes (Seconds --) into a
  2: 60     Interval (same units as above)
  3: 10     Set Output Flag High (Flag 0)

3: Real Time (P77)
  1: 110    Day,Hour/Minute (midnight = 0000)

4: Average (P71)
  1: 1      Reps
  2: 1      Loc [ Net_rad ]

```

5.3.4 CR10X Example Program with Wind Speed Correction

This example measures the NR-LITE2 using a single-ended input and Instruction 1. The program also measures wind speed and applies the correction factor as described in Section 1.4. Average net radiation and wind speed are output every hour.

NR-LITE2 Wiring for Example 4

Color	Function	Example CR10X Program Channels Used
Red	Radiation Signal	S.E. Channel 1
Blue	Signal Reference	AG
Black	Shield	G

```

;{CR10X}
;
*Table 1 Program
  01: 60      Execution Interval (seconds)

;measure 05103 wind speed

1: Pulse (P3)
  1: 1      Reps
  2: 1      Pulse Channel 1
  3: 21     Low Level AC, Output Hz
  4: 1      Loc [ Wspd_m_s ]
  5: .0980  Mult
  6: 0      Offset

;measure NR-LITE2 net radiation

2: Volt (SE) (P1)
  1: 1      Reps
  2: 3**    25 mV Slow Range
  3: 1*     SE Channel
  4: 2*     Loc [ Rn_obs ]
  5: 63.29  Mult
  6: 0      Offset
;Multiplier for specific sensor
;in units of (W m-2)/mV (see above)

```

```

;apply wind speed correction factor
;Rn.cor = Rn.obs*(1.0+0.021286*(U-5.0)) when U > 5 m/s

3: If (X<=>F) (P89)
1: 1      X Loc [ Wspd_m_s ]
2: 3      >=
3: 5      F
4: 30     Then Do

    4: Z=X+F (P34)
      1: 1      X Loc [ Wspd_m_s ]
      2: -5     F
      3: 24     Z Loc [ scratch_1 ]

    5: Z=X*F (P37)
      1: 24     X Loc [ scratch_1 ]
      2: .021286 F
      3: 25     Z Loc [ scratch_2 ]

    6: Z=X+F (P34)
      1: 25     X Loc [ scratch_2 ]
      2: 1      F
      3: 26     Z Loc [ scratch_3 ]

    7: Z=X*Y (P36)
      1: 26     X Loc [ scratch_3 ]
      2: 2      Y Loc [ Rn_obs ]
      3: 3      Z Loc [ Rn_cor ]

8: Else (P94)

    9: Z=X (P31)
      1: 2      X Loc [ Rn_obs ]
      2: 3      Z Loc [ Rn_cor ]

10: End (P95)

11: If time is (P92)
1: 0      Minutes (Seconds --) into a
2: 60     Interval (same units as above)
3: 10     Set Output Flag High (Flag 0)

12: Real Time (P77)
1: 1220   Year,Day,Hour/Minute (midnight = 2400)

13: Average (P71)
1: 1      Reps
2: 3      Loc [ Rn_cor ]

14: Average (P71)
1: 1      Reps
2: 1      Loc [ Wspd_m_s ]

```

* Proper entries will vary with program and input channel assignments.

** 25 mV range for CR10(X) and CR510, the 50 mV range for CR23X, and the 15 mV range for 21X and CR7.

6. Maintenance

The radiometer is an ‘all weather’ instrument and is very stable, but should be handled with care. It requires little periodic maintenance, apart from cleaning the sensor surfaces carefully with a soft cloth using water or alcohol.

The NR-LITE2 should be recalibrated every two years. Contact CSI for an RMA number before returning the sensor for recalibration.

7. Troubleshooting

7.1 Checking Sensor Operation

To effectively check the instrument’s operation, you will need:

1. The NR-LITE2 itself
2. A voltmeter, range 0 to 50 mV, with an input impedance greater than 5000 Ohms
3. A light source
4. A table or bench

Position the radiometer so that its downward facing sensor is about 10 mm (0.4”) above a flat surface (table or bench), and the upwards facing sensor is facing the light source (lamp). Do not touch the sensor head itself, as this will introduce thermal shocks. Hold the instrument only by its mounting arm at all times.

Follow the procedure outlined below:

- Connect the NR-LITE2 wires to the voltmeter. Connect the red wire to the positive lead and the blue wire to the negative lead.
- Select the most sensitive range on the voltmeter.
- With the lamp switched off, read the sensor output signal – allow a minute or so for the signal to fully stabilize.
- Switch on the lamp. The sensor should now produce a higher positive reading.
- Turn the lamp off again, when the signal should slowly return to its original level, proving the sensor’s sensitivity to light.
- Turn the sensor upside down. The signal value should reverse in sign (i.e. a +10 mV signal should become a –10 mV signal). Don’t worry if the two values are not exactly the same (up to 10% difference) as the sensor profiles can vary. After completing this test, return the sensor to its original orientation and let it stabilize.

- Put your hand over the upper sensor. Assuming that your hand is at a higher temperature than the sensor the positive reading should increase. Conversely, if the sensor is warmer than your hand the reading will decrease.
- Check the radiometer's sensitivity to thermal shocks by touching the edge of the sensor (the blank metal) with your hand for some seconds. The resultant shock will result in a signal drift, or a zero offset that will take some time to settle back to zero.
- Adjust the range of the voltmeter so that the expected full-scale output of the radiometer is about the same as the range of the voltmeter. A (theoretical) way to calculate the maximum expected output for normal meteorological applications is shown below:

Max. expected radiation $+1500 \text{ W m}^{-2}$

Min. radiation -200 W m^{-2}

Sensitivity of the net radiometer $10 \mu\text{V}/(\text{W m}^{-2})$

Expected output range of the radiometer is $(1500+200) \times 10 = 1700 \times 10 = 17.0 \text{ mV}$ or 0.017 V .

7.2 Radiometer produces no apparent output

If your net radiometer does not appear to be working at all, do the following checks:

- Check the instrument's sensitivity to radiation, following the procedure shown in Section 7.1.
- If this appears to produce no results, measure the impedance of the sensor across the red and blue wires. The impedance reading should be close to 2.3Ω . If it is virtually zero, a short circuit is indicated. If it is 'infinite', the thermopile is blown.

7.3 Readings are not as expected

- Under full sunlight the expected radiation value is about 1000 W m^{-2} . Under lamps it may be greater. For indoor climate studies, smaller values are to be expected unless solar radiation is present. A typical value for a room when facing a wall and a relatively cold window is 50 W m^{-2} .
- Are you using the correct calibration factor? Note that this factor is unique for each individual sensor as noted on the calibration certificate provided with that sensor. Did you convert the factor to the correct value for the datalogger program? (See Section 5, above).
- Check the datalogger program for errors.

If you cannot resolve your problems, please contact Campbell Scientific for further advice.

Campbell Scientific Companies

Campbell Scientific, Inc. (CSI)

815 West 1800 North
Logan, Utah 84321
UNITED STATES
www.campbellsci.com • info@campbellsci.com

Campbell Scientific Africa Pty. Ltd. (CSAf)

PO Box 2450
Somerset West 7129
SOUTH AFRICA
www.csafrica.co.za • cleroux@csafrica.co.za

Campbell Scientific Australia Pty. Ltd. (CSA)

PO Box 444
Thuringowa Central
QLD 4812 AUSTRALIA
www.campbellsci.com.au • info@campbellsci.com.au

Campbell Scientific do Brazil Ltda. (CSB)

Rua Luisa Crapsi Orsi, 15 Butantã
CEP: 005543-000 São Paulo SP BRAZIL
www.campbellsci.com.br • suporte@campbellsci.com.br

Campbell Scientific Canada Corp. (CSC)

11564 - 149th Street NW
Edmonton, Alberta T5M 1W7
CANADA
www.campbellsci.ca • dataloggers@campbellsci.ca

Campbell Scientific Centro Caribe S.A. (CSCC)

300 N Cementerio, Edificio Breller
Santo Domingo, Heredia 40305
COSTA RICA
www.campbellsci.cc • info@campbellsci.cc

Campbell Scientific Ltd. (CSL)

Campbell Park
80 Hathern Road
Shepshed, Loughborough LE12 9GX
UNITED KINGDOM
www.campbellsci.co.uk • sales@campbellsci.co.uk

Campbell Scientific Ltd. (France)

Miniparc du Verger - Bat. H
1, rue de Terre Neuve - Les Ulis
91967 COURTABOEUF CEDEX
FRANCE
www.campbellsci.fr • info@campbellsci.fr

Campbell Scientific Spain, S. L.

Avda. Pompeu Fabra 7-9, local 1
08024 Barcelona
SPAIN
www.campbellsci.es • info@campbellsci.es

Please visit www.campbellsci.com to obtain contact information for your local US or International representative.