

# INSTRUCTION MANUAL



## Model HMP155A Temperature and Relative Humidity Probe

Revision: 6/11



Copyright © 1990-2011  
Campbell Scientific, Inc.

## WARRANTY AND ASSISTANCE

This equipment is warranted by CAMPBELL SCIENTIFIC (CANADA) CORP. ("CSC") to be free from defects in materials and workmanship under normal use and service for **twelve (12) months** from date of shipment unless specified otherwise. \*\*\*\*\* **Batteries are not warranted.** \*\*\*\*\* CSC's obligation under this warranty is limited to repairing or replacing (at CSC's option) defective products. The customer shall assume all costs of removing, reinstalling, and shipping defective products to CSC. CSC will return such products by surface carrier prepaid. This warranty shall not apply to any CSC products which have been subjected to modification, misuse, neglect, accidents of nature, or shipping damage. This warranty is in lieu of all other warranties, expressed or implied, including warranties of merchantability or fitness for a particular purpose. CSC is not liable for special, indirect, incidental, or consequential damages.

Products may not be returned without prior authorization. To obtain a Return Merchandise Authorization (RMA), contact CAMPBELL SCIENTIFIC (CANADA) CORP., at (780) 454-2505. An RMA number will be issued in order to facilitate Repair Personnel in identifying an instrument upon arrival. Please write this number clearly on the outside of the shipping container. Include description of symptoms and all pertinent details.

CAMPBELL SCIENTIFIC (CANADA) CORP. does not accept collect calls.

Non-warranty products returned for repair should be accompanied by a purchase order to cover repair costs.



**CAMPBELL SCIENTIFIC**  
C A N A D A C O R P .

11564 - 149 street - edmonton - alberta - T5M 1W7  
tel 780.454.2505 fax 780.454.2655

[www.campbellsci.ca](http://www.campbellsci.ca)

# ***PLEASE READ FIRST***

## **About this manual**

Please note that this manual was originally produced by Campbell Scientific Inc. (CSI) primarily for the US market. Some spellings, weights and measures may reflect this origin.

Some useful conversion factors:

<b>Area:</b>	1 in <sup>2</sup> (square inch) = 645 mm <sup>2</sup>
<b>Length:</b>	1 in. (inch) = 25.4 mm 1 ft (foot) = 304.8 mm 1 yard = 0.914 m 1 mile = 1.609 km
<b>Mass:</b>	1 oz. (ounce) = 28.35 g 1 lb (pound weight) = 0.454 kg
<b>Pressure:</b>	1 psi (lb/in <sup>2</sup> ) = 68.95 mb
<b>Volume:</b>	1 US gallon = 3.785 litres

In addition, part ordering numbers may vary. For example, the CABLE5CBL is a CSI part number and known as a FIN5COND at Campbell Scientific Canada (CSC). CSC Technical Support will be pleased to assist with any questions.

# **HMP155A Table of Contents**

---

*PDF viewers note: These page numbers refer to the printed version of this document. Use the Adobe Acrobat® bookmarks tab for links to specific sections.*

<b>1. General Description</b> .....	1
<b>2. Specifications</b> .....	2
2.1 Temperature Sensor .....	4
2.2 Relative Humidity Sensor .....	4
<b>3. Installation</b> .....	5
3.1 Siting.....	5
3.2 Assembly and Mounting.....	5
<b>4. Wiring</b> .....	7
<b>5. Example Programs</b> .....	8
<b>6. Long Lead Lengths</b> .....	11
<b>7. Absolute Humidity</b> .....	14
<b>8. Sensor Maintenance</b> .....	17
8.1 Periodic Maintenance .....	17
8.1.1 Cleaning.....	17
8.1.2 Changing the Probe Filter .....	17
<b>9. Troubleshooting</b> .....	19
<b>10. References</b> .....	20
 <b>Appendix</b>	
<b>A. Interfacing with HMP155A RS485 Output</b> .....	A-1

## **Figures**

2-1. Probe Dimensions.....	2
2-2. Wiring of HMP155A 8-Pin Connector.....	3
3-1. HMP155A and 14-Plate Radiation Shield on a Tripod Mast .....	6
3-2. HMP155A and 14-Plate Radiation Shield on a CM200 Series Crossarm ....	6
8-1. Changing the Filter .....	18

## **Tables**

1-1. Recommended Lead Lengths .....	1
4-1. Connections for Single-Ended Measurements.....	7
4-2. Connections for Differential Measurements.....	8
4-3. Power Connections using SW12V Power Switch .....	8
5-1. Parameters for Temperature .....	9
5-2. Parameters for Relative Humidity .....	9
5-3. Wiring for Single-ended Measurement Examples.....	9
6-1. Wiring for Differential Measurement Examples .....	12
7-1. Wiring for Vapor Pressure Examples.....	15
8-1. Chemical Tolerances of HMP155A.....	19

# Model HMP155A Temperature and Relative Humidity Probe

---

## 1. General Description

The HMP155A Temperature and Relative Humidity probe contains a Platinum Resistance Temperature detector (PRT) and a Vaisala HUMICAP® 180 capacitive relative humidity sensor.

The HMP155A outputs a 0 to 1 VDC signal for temperature and relative humidity that can be measured by all models of CSI dataloggers with model HMP155ACBL1 cable. The HMP155A also has RS485 outputs for temperature and relative humidity that can be interfaced to the CR800, CR1000 and CR3000 dataloggers with model HMP155ACBL2 cable and the SDM-SIO1 Serial I/O Module as described in Appendix A. Enabling the RS485 outputs will result in higher current drain than listed in the specifications.

The -L option on the model HMP155A Temperature and Relative Humidity probe (HMP155A-L) indicates that the cable length is user specified. This manual refers to the sensor as the HMP155A.

The HMP155A can be powered continuously or the power may be switched to conserve battery life. The HMP155A consumes less than 3 milliamperes current at 12 volts. Approximately 2 seconds is required for the sensor to warm up after power is switched on. At measurement rates slower than once per 5 seconds, the overall power consumption (datalogger and sensors) may be reduced by switching power to the HMP155A. Most current Campbell Scientific dataloggers have a built-in switched 12 volts that can be used to control power.

**NOTE**

---

HMP155 sensors purchased directly from Vaisala Inc. with SNs < E4430001 require approximately 5 seconds warm up time.

---

The CR9000, CR510, CR500, CR7, CR10 and 21X dataloggers do not have a built-in switched 12 volts. Users with these dataloggers can power the sensor continuously or purchase the model SW12V to switch power.

Lead length for the HMP155A is specified when the sensor is ordered. Table 1-1 gives the recommended lead length for mounting the sensor at the top of the tripod/tower with a 2 foot crossarm. Lead length can be 2 feet shorter when the sensor is mounted to the tripod mast / tower leg without a crossarm.

TABLE 1-1. Recommended Lead Lengths							
CM6	CM10	CM110	CM115	CM120	UT10	UT20	UT30
11'	14'	14'	19'	24'	14'	24'	37'

The HMP155A ships with:

- (1) Adjustment Screwdriver from mfg
- (1) Calibration Sheet
- (1) Instruction Manual

## 2. Specifications

### Operating Environment

Operating temperature range for humidity measurement	-80° ... +60°C (-112° ... +140°F)
Storage temperature range	-80° ... +60°C (-112° ... +140°F)
Electromagnetic compatibility	Complies with EMC standard EN61326-1, Electrical equipment for measurement control and laboratory use - EMC requirements for use in industrial locations

### Dimensions in mm (inches)

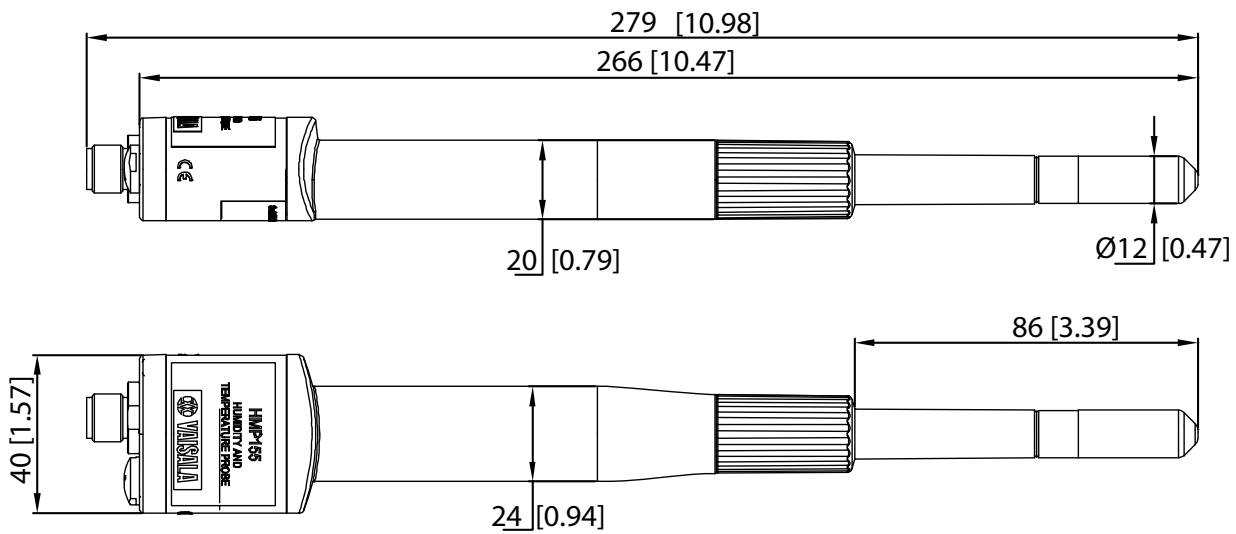
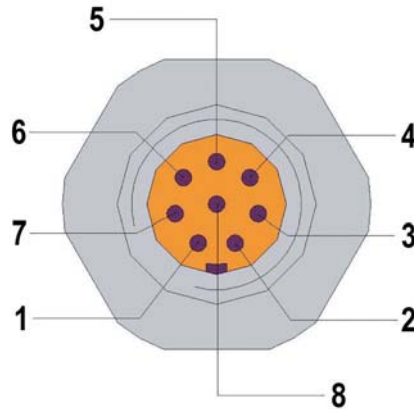

FIGURE 2-1. Probe Dimensions

**8-Pin Connector**



0507-044

FIGURE 2-2. Wiring of HMP155A 8-Pin Connector

\*HMP155A CBL1 Cable provided by Campbell Scientific

1= $V_{OUT1}$  (yellow, temp)

2=RS-485-B (no connection)

3= $A_{GND}$  (white)

4= $V_{OUT2}$  (blue, RH)

5=(no connection)

6=RS-485-A (no connection)

7= $V_{CC}$  (red)

8=GND (black)

- =SHIELD (clear)

\*Note: HMP155A CBL2 for RS485 is described in Appendix A.

**Mechanics**

Filter	Sintered PTFE
Housing material	PC
Housing classification	IP66
Weight	86 g (3 oz)

**Inputs and Outputs**

Voltage outputs	0 ... 1 V
Average current consumption	<3 mA (analog output mode)
Operating voltage	7 ... 28 VDC
Settling time at power-up	2 s

## 2.1 Temperature Sensor

Measurement range	-80° ... +60°C (-112° ... +140°F)
Accuracy with voltage output	
at -80° ... +20°C	$\pm(0.226 - 0.0028 \times \text{temperature}) \text{ } ^\circ\text{C}$
at +20° ... +60°C	$\pm(0.055 + 0.0057 \times \text{temperature}) \text{ } ^\circ\text{C}$

See graph below

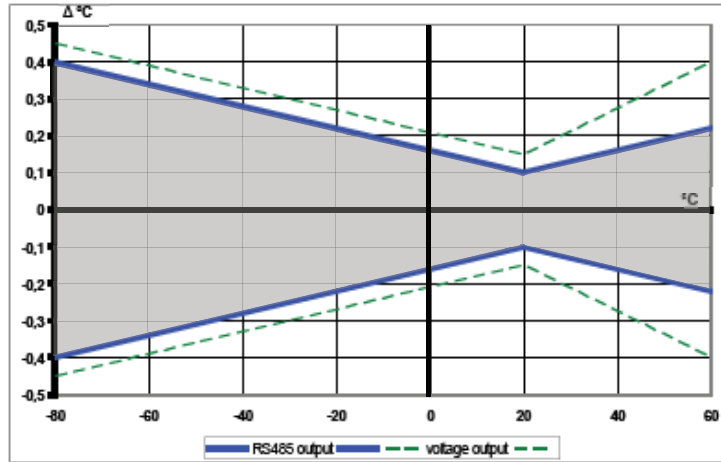

0804-032

Temperature sensor	Pt 100 RTD 1/3 Class B IEC 751
Response time (63 %) for additional temperature probe in 3 m/s air flow	
	63% <20 s
	90% <35 s

## 2.2 Relative Humidity Sensor

Measurement range	0 ... 100% RH
Accuracy (including non-linearity, hysteresis and repeatability)	
at +15° ... 25°C (59 ... 77°F)	$\pm 1\% \text{ RH (0 ... 90\% RH)}$ $\pm 1.7\% \text{ RH (90 ... 100\% RH)}$
at -20° ... +40°C (-4° ... 104°F)	$\pm (1.0 + 0.008 \times \text{reading}) \text{ } \% \text{ RH}$
at -40° ... -20°C (-40° ... -4°F)	$\pm (1.2 + 0.012 \times \text{reading}) \text{ } \% \text{ RH}$
at +40° ... +60°C (104° ... 140°F)	$\pm (1.2 + 0.012 \times \text{reading}) \text{ } \% \text{ RH}$
at -60° ... -40°C (-76° ... -40°F)	$\pm (1.4 + 0.032 \times \text{reading}) \text{ } \% \text{ RH}$
Factory calibration uncertainty (+20°C)	$\pm 0.6\% \text{ RH (0 ... 40\% RH)}$ $\pm 1.0\% \text{ RH (40 ... 97\% RH)}$ (Defined as $\pm 2$ standard deviation limits. Small variations possible, see also calibration certificate.)

Humidity sensor HUMICAP®180R

Response time for HUMICAP®180R(C) at 20°C in still air with sintered PTFE filter	
	63% 20 s
	90% 60 s

**NOTE**

The black outer jacket of the cable is Santoprene® rubber. This compound was chosen for its resistance to temperature extremes, moisture, and UV degradation. However, this jacket will support combustion in air. It is rated as slow burning when tested according to U.L. 94 H.B. and will pass FMVSS302. Local fire codes may preclude its use inside buildings.

---

## 3. Installation

### 3.1 Siting

Sensors should be located over an open level area at least 9 m (EPA) in diameter. The surface should be covered by short grass, or where grass does not grow, the natural earth surface. Sensors should be located at a distance of at least four times the height of any nearby obstruction, and at least 30 m (EPA) from large paved areas. Sensors should be protected from thermal radiation, and adequately ventilated.

Standard measurement heights:

1.5 m +/- 1.0 m (AASC)  
1.25 – 2.0 m (WMO)  
2.0 m (EPA)

See Section 10 for a list of references that discuss temperature and relative humidity sensors.

### 3.2 Assembly and Mounting

Tools Required:

- 1/2" open end wrench
- small screw driver provided with datalogger
- UV resistant cable ties
- small pair of diagonal-cutting pliers

The HMP155A must be housed inside a radiation shield when exposed to solar radiation. The 14-plate radiation shield has a U-bolt for attaching the shield to tripod mast / tower leg (Figure 3-1), or CM200 series crossarm (Figure 3-2). The radiation shield ships with the U-bolt configured for attaching the shield to a vertical pipe. Move the U-bolt to the other set of holes to attach the shield to a crossarm.

Loosen the split-nut on the bottom plate of the 14-plate radiation shield. Remove the yellow protective cap on the HMP155A, and insert the sensor into the shield. Tighten the split-nut to secure the sensor in the shield. Route the sensor cable to the instrument enclosure. Secure the cable to the tripod/tower using cable ties.



FIGURE 3-1. HMP155A and 14-Plate Radiation Shield on a Tripod Mast



FIGURE 3-2. HMP155A and 14-Plate Radiation Shield on a CM200 Series Crossarm

## 4. Wiring

Connections to Campbell Scientific dataloggers are given in Tables 4-1 through 4-3. The probe can be measured by two single-ended or differential analog input channels (recommended for lead lengths > 6.1 m (20 ft.), see Section 6). The CR200(X)-series dataloggers only have single-ended channels.

**CAUTION**

When measuring the HMP155A with single-ended measurements, the white and black leads must both be connected to AG on the CR10(X) and CR500/CR510 or to  $\ominus$  on the CR1000, CR5000, and CR23X. Doing otherwise will connect the datalogger's analog and power ground planes to each other, which in some cases can cause offsets on low-level analog measurements. To avoid 3 mA flowing into analog ground, switch the sensor on/off for its own measurement.

**TABLE 4-1. Connections for Single-Ended Measurements**

Color	Wire Label	CR10X	CR1000, CR3000, CR800, CR5000, CR23X	CR10, CR510, CR500	21X, CR7	CR200(X)
Yellow	Temp Signal	Single-Ended Input	Single-Ended Input	Single-Ended Input	Single-Ended Input	Single-Ended Input
Blue	RH Signal	Single-Ended Input	Single-Ended Input	Single-Ended Input	Single-Ended Input	Single-Ended Input
White	Signal Reference	AG	$\ominus$	AG	$\ominus$	$\ominus$
Black	Signal Ground	AG	$\ominus$	AG	$\ominus$	$\ominus$
Clear	Shield	G	$\ominus$	G	$\ominus$	$\ominus$
Red	Power SW12V	SW12V	SW12V	12V/SW12V*	12V/SW12V*	SW Power
		If using SW12V, jumper from SW12V Control to Control Port				

\*On these dataloggers switched power is only available with the SW12V peripheral.

**TABLE 4-2. Connections for Differential Measurements**

<b>Color</b>	<b>Wire Label or Description</b>	<b>CR10X</b>	<b>CR1000, CR3000, CR800, CR5000, CR23X</b>	<b>CR10, CR510, CR500</b>	<b>21X, CR7</b>
Yellow	Temp Signal	Differential Input – H	Differential Input – H	Differential Input – H	Differential Input – H
	Jumper to White	Differential Input – L	Differential Input – L	Differential Input – L	Differential Input – L
Blue	RH Signal	Differential Input – H	Differential Input – H	Differential Input – H	Differential Input – H
White	Signal Reference	Differential Input – L	Differential Input – L	Differential Input – L	Differential Input – L
Black	Signal Ground	G	G	G	⊕
Clear	Shield	G	⊕	G	⊕
Red	Power SW12V	12V/SW12V	12V/SW12V	12V/SW12V*	12V/SW12V*
		If using SW12V, jumper from SW12V Control to Control Port			

\*On these dataloggers switched power is only available with the SW12V Power Switch (ordered separately).

**TABLE 4-3. Power Connections using SW12V Power Switch**

<b>HMP155A</b>		<b>SW12V Peripheral</b>		<b>Datalogger</b>
<b>Color</b>	<b>Description</b>	<b>Terminal</b>	<b>Wire</b>	
Red	Power	SW12V	Red	12 V
Black	Power Ground	GND	Black	G*
			Green	Control Port

\*The black wire of the SW12V should be connected to the type of datalogger ground channel recommended for the HMP155A black wire as listed in Table 4-1 and Table 4-2.

## 5. Example Programs

This section is for users who write their own datalogger programs. A datalogger program to measure this sensor can be created using Campbell Scientific’s Short Cut Program Builder software. You do not need to read this section to use Short Cut.

The temperature and relative humidity signals from the HMP155A can be measured using a single-ended analog measurement or a differential analog measurement.

Use a single-ended analog measurement when the HMP155A signal lead length is less than 6.1 m (20 ft.) or if the probe will be turned on and off under datalogger control between measurements. For lead lengths greater than 6.1 m (20 ft.) or when the probe will be continuously powered, use a differential analog measurement. For a discussion on errors caused by long lead lengths see Section 6.

**NOTE**

HMP155 sensors purchased directly from Vaisala Inc. with SNs < E4430001 require approximately 5 seconds warm up time.

The HMP155A output scale is 0 to 1000 millivolts for the temperature range of -80°C to +60°C (-112 to +140°F) and for the relative humidity range of 0 to 100%. Multipliers and offsets for converting voltage to temperature and relative humidity are listed in Tables 5-1 and 5-2 respectively.

<b>TABLE 5-1. Parameters for Temperature</b>		
<b>Units</b>	<b>Multiplier (degrees mV<sup>-1</sup>)</b>	<b>Offset (degrees)</b>
Celsius	0.14	-80
Fahrenheit	0.252	-112

<b>TABLE 5-2. Parameters for Relative Humidity</b>		
<b>Units</b>	<b>Multiplier (% mV<sup>-1</sup>)</b>	<b>Offset (%)</b>
Percent	0.1	0
Fraction	0.001	0

<b>TABLE 5-3. Wiring for Single-ended Measurement Examples</b>			
<b>Color</b>	<b>Description</b>	<b>CR1000</b>	<b>CR10(X)</b>
Yellow	Temperature	SE 2 (1L)	SE 3 (2H)
Blue	Relative Humidity	SE 1 (1H)	SE 4 (2L)
White	Signal Reference	⊕	AG
	Jumper from SW12V Control		C1
Red	Power	SW12V	SW12 V
Black	Power Ground	⊕	AG
Clear	Shield	⊕	G

**CR1000 Program using Single-Ended Measurement Instructions Using SW12V on Datalogger**

```
'CR1000 program to measure HMP155A with single-ended measurements

Public AirTC
Public RH

DataTable(Temp_RH,True,-1)
  DataInterval(0,60,Min,0)
  Average(1,AirTC,IEEE4,0)
  Sample(1,RH,IEEE4)
EndTable

BeginProg
  Scan(5,Sec,1,0)
  'HMP155A Temperature & Relative Humidity Sensor measurements AirTC and RH:
  PortSet (9,1)
  Delay(0,5,Sec)
  VoltSE(AirTC,1,mV2500,2,0,0,_60Hz,.14,-80)
  VoltSE(RH,1,mV2500,1,0,0,_60Hz,0.1,0)
  PortSet (9,0)
  If RH>100 And RH<108 Then RH=100
  CallTable(Temp_RH)
  NextScan
EndProg
```

**CR10(X) Program using Single-Ended Measurement Instructions Using SW12V on Datalogger**

```
;Turn the HMP155A on.
;
01: Do (P86)
  1: 41           Set Port 1 High                   ;;Jumper wire from SW12V control to C1
                                                  ;;Green wire (C1) if using SW12V Power Switch
                                                  ;;For CR23X or CR5000 use 49 for SW12V internal
                                                  ;;control port

;;Pause 2 seconds before making measurements so the
;;probe can stabilize on true readings.
;
02: Excitation with Delay (P22)
  1: 1            Ex Channel
  2: 0            Delay W/Ex (units = 0.01 sec)
  3: 500          Delay After Ex (units = 0.01 sec)
  4: 0            mV Excitation
```

```

;Measure the HMP155A temperature.
;
03: Volt (SE) (P1)
  1: 1      Repts
  2: 5      2500 mV Slow Range      ;CR510, CR500 (2500mv); CR23X (1000 mV);
                                       21X, CR7 (5000 mV)
  3: 3      SE Channel              ;Yellow wire (SE 3), white or purple wire (AG)
  4: 1      Loc [ T_C      ]
  5: .14    Mult                    ;See Table 5-1 for alternative multipliers
  6: -80    Offset                  ;See Table 5-1 for alternative offsets

;Measure the HMP155A relative humidity.
;
04: Volt (SE) (P1)
  1: 1      Repts
  2: 5      2500 mV Slow Range      ;CR510, CR500 (2500 mV); CR23X (1000 mV);
                                       21X, CR7 (5000 mV)
  3: 4      SE Channel              ;Blue wire (SE 4), white or purple wire (AG)
  4: 2      Loc [ RH_pct  ]
  5: .1     Mult                    ;See Table 5-2 for alternative multipliers
  6: 0      Offset

;Turn the HMP155A off.
;
05: Do (P86)
  1: 51     Set Port 1 Low          ;Jumper wire from SW12V control to C1
                                       ;Orange wire (C1) if older wiring
                                       ;Green wire (C1) if using SW12V device
                                       ;For CR23X or CR5000 use 59 for SW12V internal
                                       ;control port

```

## 6. Long Lead Lengths

This section describes the error associated with measuring the HMP155A with a single-ended measurement if the probe has a long cable. To avoid these problems, CSI recommends measuring the HMP155A using a differential analog measurement (Instruction 2) when long lead lengths are required. Generic datalogger connections for measuring the HMP155A using a differential measurement are given in Table A-2.

Understanding the details in this section is not required for the general operation of the HMP155A with Campbell Scientific's dataloggers.

The signal reference (white) and the power ground (black) are in common inside the HMP155A. When the HMP155A temperature and relative humidity are measured using a single-ended analog measurement, both the signal reference and power ground are connected to ground at the datalogger. The signal reference and power ground both serve as the return path for 12 V. There will be a voltage drop along those leads because the wire itself has resistance. The HMP155A draws approximately 4 mA when it is powered. The wire used in the HMP155A (P/N 9721) has resistance of 27.7 Ω/1000 feet. Since the signal reference and the power ground are both connected to ground at the datalogger, the effective resistance of those wires together is half of 27.7

$\Omega/1000$  feet, or  $13.9 \Omega/1000$  feet. Using Ohm's law, the voltage drop ( $V_d$ ), along the signal reference/power ground, is given by Eq. (1).

$$\begin{aligned}
 V_d &= I * R \\
 &= 4 \text{ mA} * 13.9 \Omega / 1000 \text{ ft} \\
 &= 55.6 \text{ mV} / 1000 \text{ ft}
 \end{aligned}
 \tag{1}$$

This voltage drop will raise the apparent temperature and relative humidity because the difference between the signal and signal reference lead, at the datalogger, has increased by  $V_d$ . The approximate error in temperature and relative humidity is  $0.56^\circ\text{C}$  and  $0.56\%$  per 100 feet of cable length, respectively.

TABLE 6-1. Wiring for Differential Measurement Examples			
Color	Description	CR1000	CR10(X)
Yellow	Temperature	2H	2H
	Jumper to 1L	2L	2L
Blue	Relative Humidity	1H	1H
White	Signal Reference	1L	1L
	Jumper from SW12V Control		C1
Red	Power	SW12 V	SW12 V
Black	Power Ground	G	G
Clear	Shield	⊕	G

**CR1000 Program using Differential Measurement Instructions Using SW12V on Datalogger**

```

'CR1000 program to measure HMP155A with differential measurements

Public AirTC
Public RH

DataTable(Temp_RH,True,-1)
  DataInterval(0,60,Min,0)
  Average(1,AirTC,IEEE4,0)
  Sample(1,RH,IEEE4)
EndTable
    
```

```

BeginProg
  Scan(5,Sec,1,0)
    'HMP155A Temperature & Relative Humidity Sensor measurements AirTC and RH:
    PortSet (9,1)
    Delay(0,2,Sec)
    VoltDiff (AirTC,1,mV2500,2,True,0, _60Hz,.14,-80)
    VoltDiff (RH,1,mV2500,1,True,0, _60Hz,0.1,0)
    PortSet (9,0)
    If RH>100 And RH<108 Then RH=100
    CallTable(Temp_RH)
  NextScan
EndProg

```

**CR10(X) Program using Differential Measurement Instructions Using SW12V on Datalogger**

```

;Turn the HMP155A on.
;
01: Do (P86)
  1: 41          Set Port 1 High          ;Jumper wire from SW12V control to C1
                                           ;Green wire (C1) if using SW12V device
                                           ;For CR23X or CR5000 use 49 for SW12V internal
                                           ;control port

;Pause 2 seconds before making measurements so the
;probe can stabilize on true readings.
;
02: Excitation with Delay (P22)
  1: 1          Ex Channel
  2: 0          Delay W/Ex (units = 0.01 sec)
  3: 500        Delay After Ex (units = 0.01 sec)
  4: 0          mV Excitation

;Measure the HMP155A temperature.
;
03: Volt (Diff) (P2)
  1: 1          Reps
  2: 5          2500 mV Slow Range        ;CR510, CR500 (2500mv); CR23X (1000 mV);
                                           ;21X, CR7 (5000 mV)
  3: 2          DIFF Channel              ;Yellow wire (3H), jumper (3L to 4L)
  4: 1          Loc [ T_C      ]
  5: .14        Mult                      ;See Table 5-1 for alternative multipliers
  6: -80        Offset                    ;See Table 5-1 for alternative offsets

```

```

;Measure the HMP155A relative humidity.
;
04: Volt (Diff) (P2)
  1: 1      Reps
  2: 5      2500 mV Slow Range      ;CR510, CR500 (2500mv); CR23X (1000 mV);
                                       21X, CR7 (5000 mV)
  3: 1      DIFF Channel            ;Blue wire (4H), white or purple wire (4L)
  4: 2      Loc [ RH_pct  ]
  5: .1     Mult                    ;See Table 5-2 for alternative multipliers
  6: 0      Offset

;Turn the HMP155A off.
;
05: Do (P86)
  1: 51     Set Port 1 Low          ;Jumper wire from SW12V control to C1
                                       ;Green wire (C1) if using SW12V device
                                       ;For CR23X or CR5000 use 59 for SW12V internal
                                       ;control port

```

## 7. Absolute Humidity

The HMP155A measures the relative humidity. Relative humidity is defined by the equation below:

$$RH = \frac{e}{e_s} * 100 \tag{2}$$

where RH is the relative humidity, e is the vapor pressure in kPa , and e<sub>s</sub> is the saturation vapor pressure in kPa. The vapor pressure, e, is an absolute measure of the amount of water vapor in the air and is related to the dew point temperature. The saturation vapor pressure is the maximum amount of water vapor that air can hold at a given air temperature. The relationship between dew point and vapor pressure, and air temperature and saturation vapor pressure are given by Goff and Gratch (1946), Lowe (1977), and Weiss (1977).

When the air temperature increases, so does the saturation vapor pressure. Conversely, a decrease in air temperature causes a corresponding decrease in saturation vapor pressure. It follows then from Eq. (2) that a change in air temperature will change the relative humidity, without causing a change absolute humidity.

For example, for an air temperature of 20°C and a vapor pressure of 1.17 kPa, the saturation vapor pressure is 2.34 kPa and the relative humidity is 50%. If the air temperature is increased by 5°C and no moisture is added or removed from the air, the saturation vapor pressure increases to 3.17 kPa and the relative humidity decreases to 36.9%. After the increase in air temperature, the air can hold more water vapor. However, the actual amount of water vapor in the air has not changed. Thus, the amount of water vapor in the air, relative to saturation, has decreased.

Because of the inverse relationship between relative humidity and air temperature, finding the mean relative humidity is meaningless. A more useful quantity is the mean vapor pressure. The mean vapor pressure can be computed on-line by the datalogger as shown in the following examples.

<b>TABLE 7-1. Wiring for Vapor Pressure Examples</b>			
<b>Color</b>	<b>Description</b>	<b>CR1000</b>	<b>CR10(X)</b>
Yellow	Temperature	SE 2 (1L)	SE 3 (2H)
Blue	Relative Humidity	SE 1 (1H)	SE 4 (2L)
White	Signal Reference	⊕	AG
	Jumper from SW12V Control		C1
Red	Power	SW12V	SW12 V
Black	Power Ground	⊕	AG
Clear	Shield	⊕	G

**CR1000 Program that Computes Vapor Pressure and Saturation Vapor Pressure**

```
'CR1000 program that calculates Vapor Pressure

Public AirTC
Public RH
Public RH_Frac, e_Sat, e_kPa

DataTable(Temp_RH,True,-1)
  DataInterval(0,60,Min,0)
  Average(1,AirTC,IEEEE4,0)
  Sample(1,RH,IEEEE4)
  Sample(1,e_kPa,IEEEE4)
EndTable

BeginProg
  Scan(5,Sec,1,0)
  'HMP155A Temperature & Relative Humidity Sensor measurements AirTC and RH:
  PortSet (9,1)
  Delay(0,2,Sec)
  VoltSE(AirTC,1,mV2500,2,0,0,_60Hz,,14,-80)
  VoltSE(RH,1,mV2500,1,0,0,_60Hz,0.1,0)
  PortSet (9,0)
  If RH>100 And RH<108 Then RH=100
  'Calculate Vapor Pressure
  'Convert RH percent to RH Fraction
  RH_Frac = RH * 0.01
  'Calculate Saturation Vapor Pressure
```

```

SatVP(e_Sat, AirTC)
'Compute Vapor Pressure, RH must be a fraction
e_kPa = e_Sat * RH_Frac
CallTable(Temp_RH)
NextScan
EndProg

```

### CR10(X) Program that Computes Vapor Pressure and Saturation Vapor Pressure

```

;Turn the HMP155A on.
;
01: Do (P86)
  1: 41      Set Port 1 High      ;Jumper wire from SW12V control to C1
                                       ;Green wire (C1) if using SW12V device
                                       ;For CR23X or CR5000 use 49 for SW12V internal
                                       ;control port

;Pause 5 seconds before making measurements so the
;probe can stabilize on true readings.
;
02: Excitation with Delay (P22)
  1: 1      Ex Channel
  2: 0      Delay W/Ex (units = 0.01 sec)
  3: 500    Delay After Ex (units = 0.01 sec)
  4: 0      mV Excitation

;Measure the HMP155A temperature.
;
03: Volt (SE) (P1)
  1: 1      Reps
  2: 5      2500 mV Slow Range      ;CR510, CR500 (2500mv); CR23X (1000 mV);
                                       ;21X, CR7 (5000 mV)
  3: 3      SE Channel              ;Yellow wire (SE 3), white or purple wire (AG)
  4: 1      Loc [ T_C      ]
  5: .14    Mult
  6: -80    Offset

;Measure the HMP155A relative humidity.
;
04: Volt (SE) (P1)
  1: 1      Reps
  2: 5      2500 mV Slow Range      ;CR510, CR500 (2500mv); CR23X (1000 mV);
                                       ;21X, CR7 (5000 mV)
  3: 4      SE Channel              ;Blue wire (SE 4), white or purple wire (AG)
  4: 2      Loc [ RH_frac  ]
  5: .001   Mult
  6: 0      Offset

```

```

;Turn the HMP155A off.
;
05: Do (P86)
    1: 51          Set Port 1 Low          ;Jumper wire from SW12V control to C1
                                           ;Green wire (C1) if using SW12V device
                                           ;For CR23X or CR5000 use 59 for SW12V internal
                                           ;control port

;Compute the saturation vapor pressure.
;The temperature must be in degrees Celsius.
;
06: Saturation Vapor Pressure (P56)
    1: 1          Temperature Loc [ T_C    ]
    2: 3          Loc [ e_sat    ]

;Compute the vapor pressure.
;Relative humidity must be a fraction.
;
07: Z=X*Y (P36)
    1: 3          X Loc [ e_sat    ]
    2: 2          Y Loc [ RH_frac  ]
    3: 4          Z Loc [ e        ]

```

## 8. Sensor Maintenance

The HMP155A Probe requires minimal maintenance. Check monthly to make sure the radiation shield is free from debris. The filter at the end of the sensor should also be checked for contaminants.

### 8.1 Periodic Maintenance

#### 8.1.1 Cleaning

Clean the probe with a soft, lint-free cloth moistened with mild detergent.

#### 8.1.2 Changing the Probe Filter

1. Remove the filter from the probe.
2. After removing the filter, check the O-ring and change it if necessary.
3. Install a new filter on the probe.

New filters can be ordered from Campbell Scientific or Vaisala.

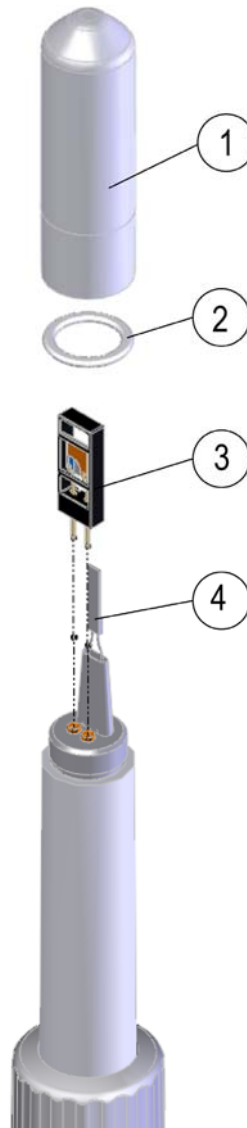

FIGURE 8-1. Changing the Filter

The following numbers refer to Figure 8-1 above:

- 1 = Filter
- 2 = O-ring
- 3 = HUMICAP<sup>®</sup> sensor
- 4 = Pt100 temperature sensor

When installed in close proximity to the ocean or other bodies of salt water (e.g., Great Salt Lake), a coating of salt (mostly NaCl) may build up on the radiation shield, sensor, filter and even the chip. NaCl has an affinity for water. The humidity over a saturated NaCl solution is 75%. A buildup of salt on the filter or chip will delay or destroy the response to atmospheric humidity.

The filter can be rinsed gently in distilled water. If necessary, the chip can be removed and rinsed as well. Do not scratch the chip while cleaning.

Long term exposure of the HUMICAP® relative humidity sensor to certain chemicals and gases may affect the characteristics of the sensor and shorten its life. Table 8-1 lists the maximum ambient concentrations, of some chemicals, that the HUMICAP® can be exposed to.

<b>TABLE 8-1. Chemical Tolerances of HMP155A</b>	
<b>Chemical</b>	<b>Concentration (PPM)</b>
Organic solvents	1000 to 10,000
Aggressive chemicals (e.g. SO <sub>2</sub> , H <sub>2</sub> SO <sub>4</sub> , H <sub>2</sub> S, HCl, Cl <sub>2</sub> , etc.)	1 to 10
Weak Acids	100 to 1000
Bases	10,000 to 100,000

Recalibrate the HMP155A annually. Obtain an RMA number before returning the HMP155A to Campbell Scientific for recalibration.

## 9. Troubleshooting

Symptom: -9999, NAN, -80 deg C, or 0 % relative humidity

1. Check that the sensor is wired to the correct input channels as specified by the measurement instructions.
2. Verify the Range code is correct for the datalogger type.
3. Verify the red power wire is correctly wired to the 12V, Switched 12V, or SW12V Power Switch. The terminal the wire is connected to will depend on the datalogger program.

Connect the red wire to a 12V terminal to constantly power the sensor for troubleshooting purposes. With the red wire connected to 12V, a voltmeter can be used to check the output voltage for temperature and relative humidity on the yellow and blue wires respectively (temperature °C = mV \* 0.14 – 80.0; relative humidity % = mV \* 0.1).

Symptom: Incorrect temperature or relative humidity

1. Verify the multiplier and offset parameters are correct for the desired units (Table 5-1).

## 10. References

- Goff, J. A. and S. Gratch, 1946: Low-pressure properties of water from -160° to 212°F, *Trans. Amer. Soc. Heat. Vent. Eng.*, **51**, 125-164.
- Lowe, P. R., 1977: An approximating polynomial for the computation of saturation vapor pressure, *J. Appl. Meteor.*, **16**, 100-103.
- Vaisala, Inc. (2008) HMP155A Humidity and Temperature Probe User Guide, Helsinki, Finland. Text and figures used with permission of Vaisala, Inc.
- Weiss, A., 1977: Algorithms for the calculation of moist air properties on a hand calculator, *Amer. Soc. Ag. Eng.*, **20**, 1133-1136.

# ***Appendix A. Interfacing with HMP155A RS485 Output***

---

## **A.1 RS485 Interface Options**

The HMP155A outputs a 0 to 1 VDC signal for temperature and relative humidity that can be measured by all models of CSI dataloggers with model HMP155ACBL1 cable. The HMP155A also has RS485 outputs for temperature and relative humidity that can be interfaced to the CR800, CR1000 and CR3000 dataloggers with model HMP155ACBL2 cable and the SDM-SIO1 Serial I/O Module. Vaisala also sells a cable with RS485 outputs which is documented in the example programs below.

The MD485 Multidrop Interface can also be used to interface the RS485 outputs to the CR800, CR1000 and CR3000 dataloggers. This option requires a USB to RS485 cable (available from Vaisala) to change the default baud rate of the RS485 output from the default of 4800 to a baud rate supported by the MD485.

## **A.2 SDM-SIO1 Serial I/O Module Interface Option**

The SDM-SIO1 module is used to interface the RS485 outputs of the HMP155A to the datalogger. The SDM-SIO1 functions like a built-in serial port to the datalogger. Data are buffered in the SDM-SIO1 and retrieved by the datalogger using standard program instructions.

The SDM-SIO1 connects to the datalogger's 12V, G, and SDM terminals (C1, C2, C3). Sensor wiring to the SDM-SIO1 and datalogger is documented in the example program below.

**Program Example for SDM-SIO1 Module:**

The following program sends the commands 'SMODE RUN' and 'R' to enable the RS485 output. SerialInRecord and Mid instructions parse the serial string and put the temperature and relative humidity values into public variables.

```
'CR1000 Series Datalogger

'Sensor Wiring:

'HMP155A with RS485 Output:
'

| HMP155A  | HMP155A                        | SDM-SIO1 | CR1000 | Connector Pin-Out |
|----------|--------------------------------|----------|--------|-------------------|
| ' CSI    | Vaisala                        |          |        |                   |
| ' Cable  | Cable                          |          |        |                   |
| ' blue   | pink                           | Y        |        | 6                 |
| ' yellow | brown                          | Z        |        | 2                 |
| ' black  | red                            |          | G      | 8                 |
| ' red    | blue                           |          | 12V    | 7                 |
| ' clear  | green                          | 0V       |        | 3                 |
| ' shield | black                          |          | Ground | not connected     |
| '        | grey, white, yellow - NOT used |          |        |                   |

'

'Declare Public Variables
Public TempC, RH, NBytesReturned
Public SerialIndest As String * 26
Public String_1 As String
Public String_2 As String

Const SensorPort=32
Const CRLF=CHR(13)+CHR(10)

SequentialMode

'Define Data Tables
DataTable (Table1,1,-1)
    DataInterval (0,15,Min,10)
    Average (1,TempC,FP2,False)
    Sample (1,RH,FP2)
EndTable

'Main Program (for sensor configured for default settings of 4800 baud, E,7,1)
BeginProg

    SerialOpen (SensorPort,4800,58,0,53)          ' buffer = 2*number of bytes + 1
                                                ' SDM-SIO1 port 58 for half duplex, 7,E,1

    'Strings to start serial output
    String_1 = "SMODE RUN"+CRLF ' set SMODE to "RUN"
    String_2 = "R"+CRLF ' send "R" to start serial output
```



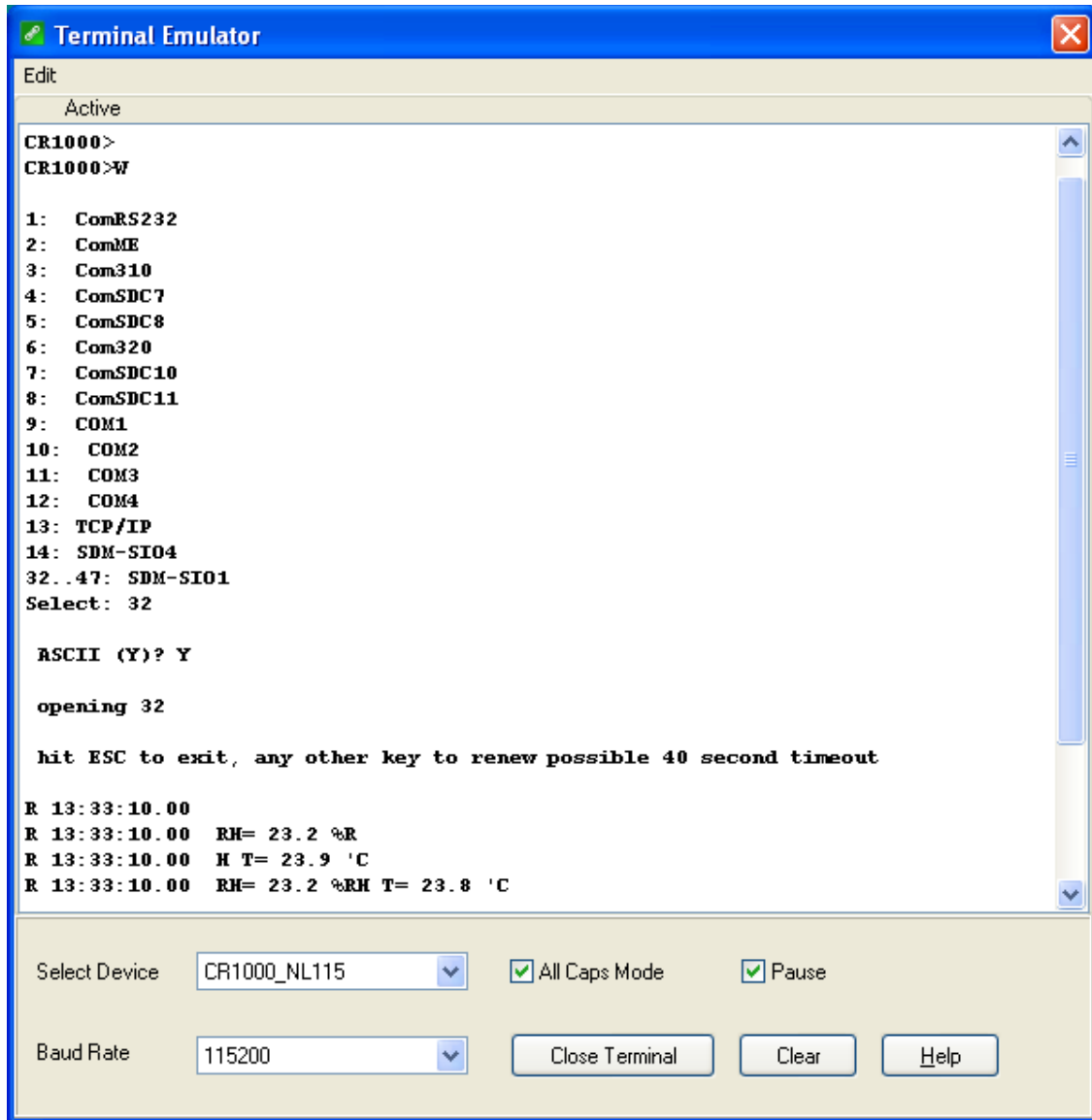

### A.3 MD485 Multidrop Interface Option

The MD485 Multidrop Interface can be used to interface the RS485 outputs of the HMP155A to the datalogger's CS I/O port. Connect the MD485's CS I/O port to the datalogger's CS I/O port with an SC12 cable. Sensor wiring to the MD485 and datalogger is documented in the example program below.

The HMP155A has a default RS485 baud rate of 4800, which must be changed to 9600 to be compatible with the MD485. To change settings in the HMP155A, Vaisala's USB to RS485 cable is required to interface the HMP155A sensor to a computer. Commands to change settings are sent to the HMP155A using a terminal emulator such as Windows HyperTerm.

Vaisala's USB to RS485 cable includes a CD with drivers that must be installed on the computer before the cable can be used. Insert the CD into the computer's CD drive and follow the prompts.

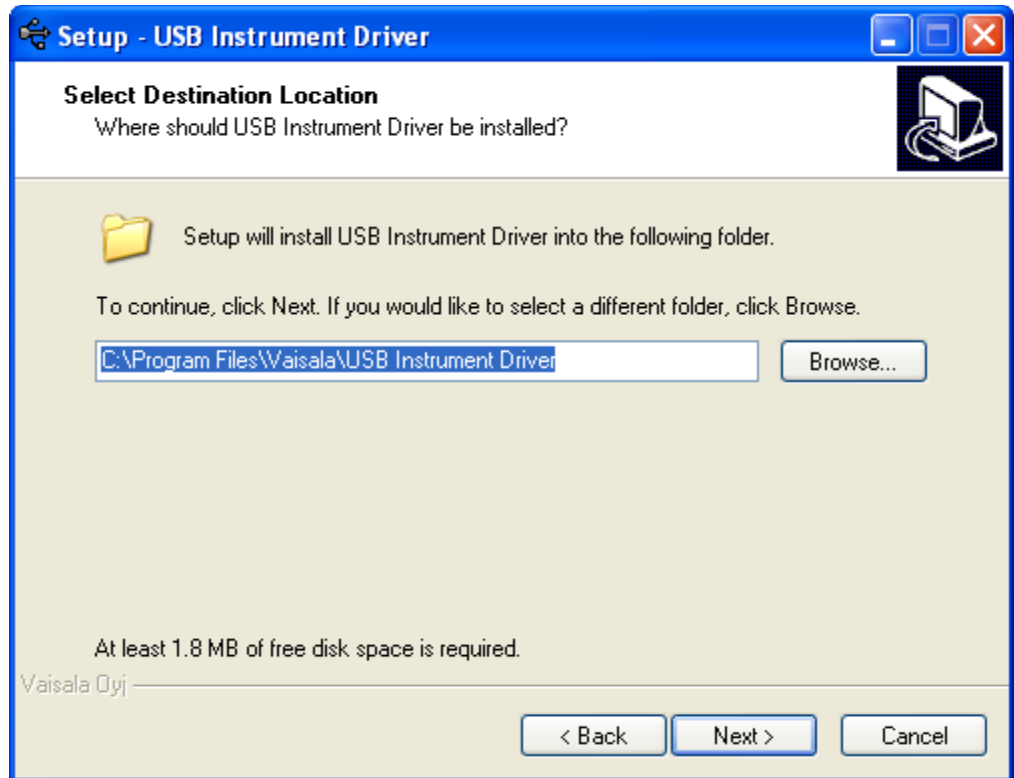

Use the Device Manager in Windows to determine which COM port the USB/RS485 cable was assigned:

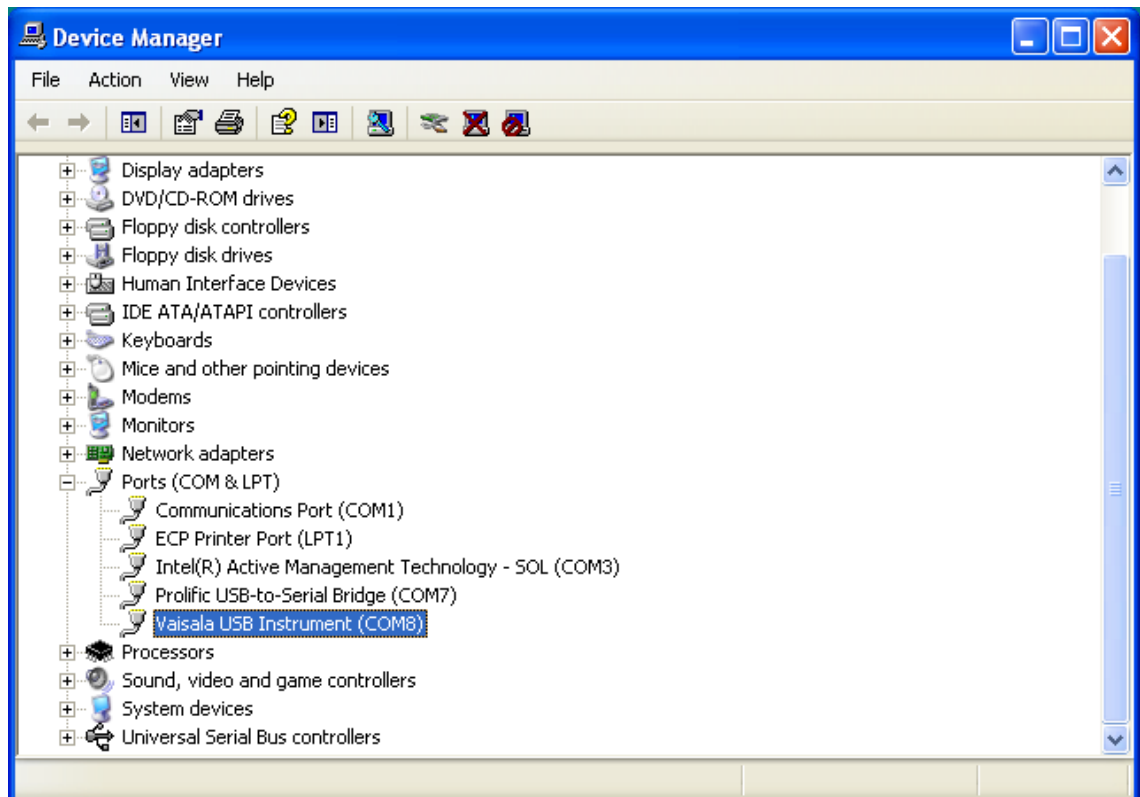

Configure Windows HyperTerminal for the appropriate COM port (e.g. COM8 in the example above) for the default HMP155A RS485 settings of 4800 baud, 8,N,1.

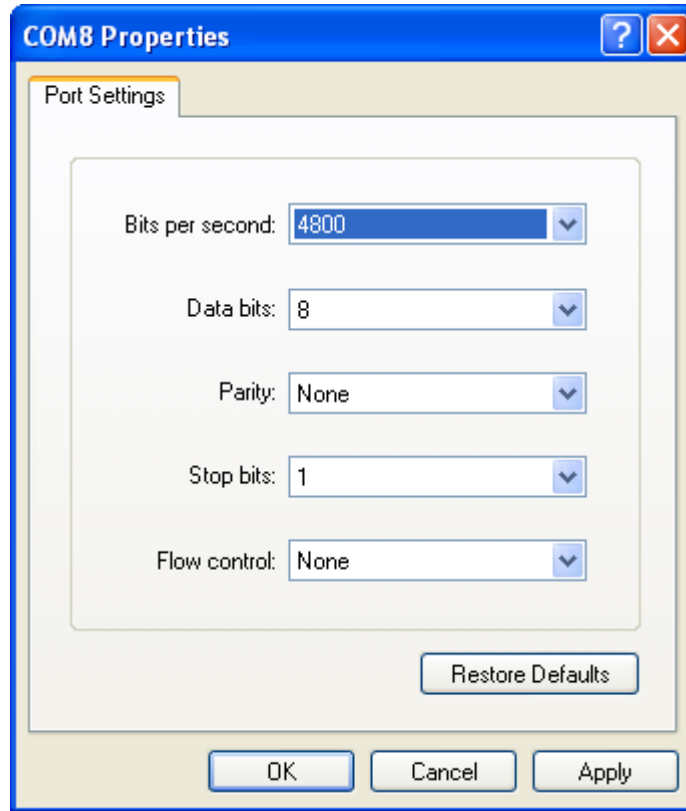

Using HyperTerminal, send the following commands to the HMP155A:

VERS[enter] to get a response from the sensor, e.g. HMP155A 1.14  
SERI[enter] to get the current RS485 settings, e.g. 4800 N 8 1  
SERI 9600 N 8 1[enter] to change the RS485 settings, response should be  
9600 N 8 1  
R[enter] to put the sensor in the Run mode to output continuous measurements

Responses to the commands are shown in the screen capture below.

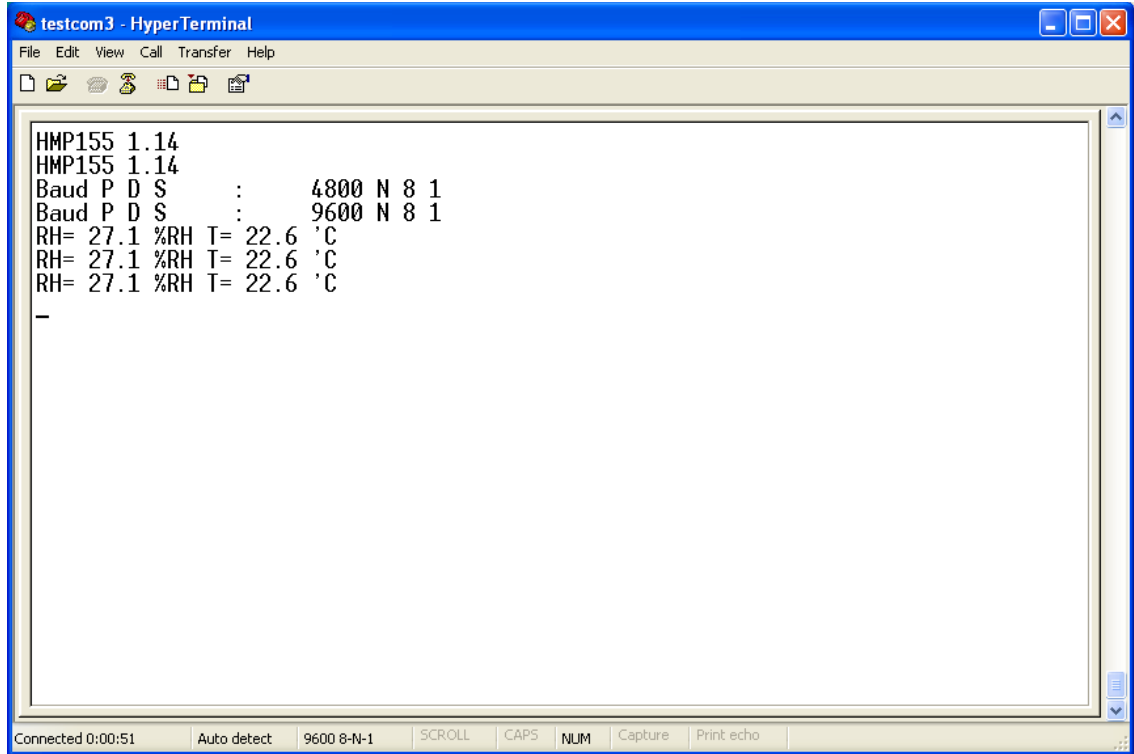

After the settings have been changed, change the baud rate in HyperTerminal to 9600, and make sure the relative humidity and temperature string is being displayed before connecting the sensor to the MD485.

### A.3.1 MD485 Multidrop Interface Configuration

Using the Device Configuration Utility, configure the MD485 as shown below.

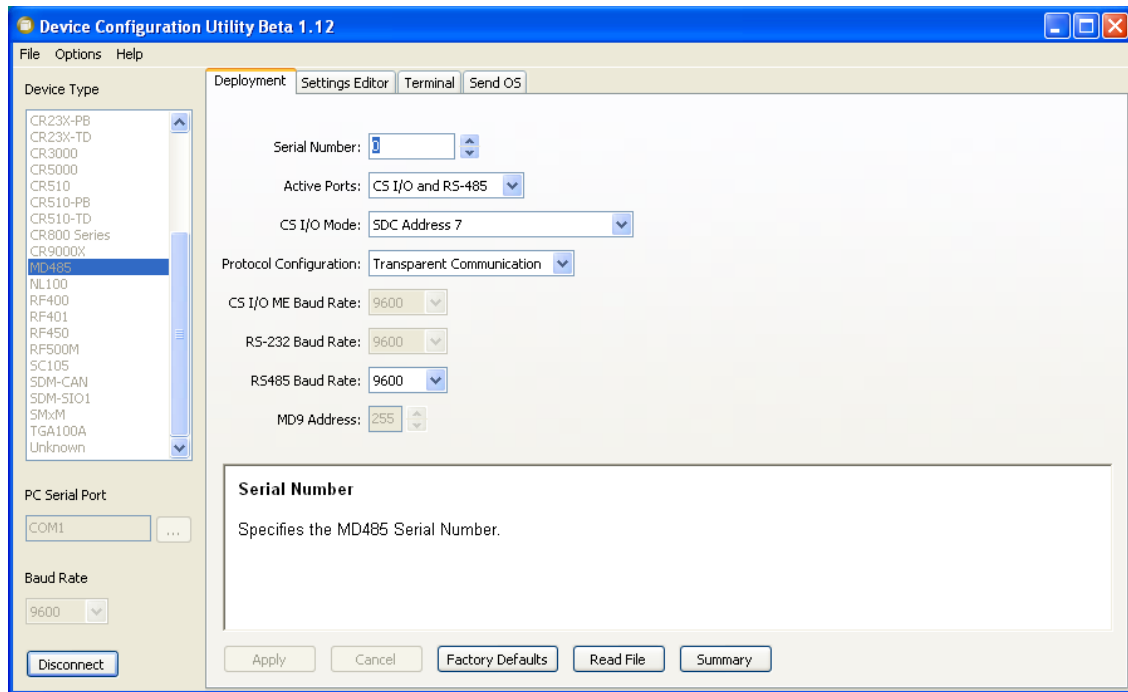

Connect the MD485 's CS I/O port the the datalogger's CS I/O port using an SC12 cable. Use the HMP155ACBL2 to connect the HMP155A sensor to the MD485 and datalogger (CR1000, CR800 or CR3000) as shown in the following table. The table also shows wiring for cables purchased from Vaisala.

HMP155A CSI Cable	HMP155A Vaisala Cable	MD485	CR1000	Connector Pin-Out
blue	pink	B		6
yellow	brown	A		2
black	red		G	8
red	blue		12V	7
white	green		Ground	3
shield (clear)	Black		Ground	not connected
	grey, pink, brown - NOT used			

## CR1000 Example Program for use with MD485

The following program sends the commands 'SMODE RUN' and 'R' to enable the RS485 output. SerialInRecord and Mid instructions parse the serial string and put the temperature and relative humidity values into public variables.

```
'CR1000 Series Datalogger

'Change HMP155A default serial settings from 4800,E,7,1 To 9600,N,8,1:

' Sensor Wiring:

' CSI cable      Vaisala cable  MD485      CR1000      Connector Pin-Out
' blue           pink           B           6
' yellow         brown          A           2
' black          red            G           8
' red            blue           12V        7
' clear          green          Ground      3
' shield         Black          Ground      not connected
'                grey, white, yellow - NOT used

'MD485 settings:
' CS I/O AND RS-485
' SDC Address 7
' Transparent Communication
' RS485 baud 9600

'Connect CS I/O port of MD485 to CS I/O port on CR1000 with SC12 cable.

'Declare Public Variables
Public TempC, RH, NBytesReturned
Public SerialIndest As String * 26
Public String_1 As String
Public String_2 As String

Const CRLF=CHR(13)+CHR(10)

SequentialMode

'Define Data Tables
DataTable (Table1,1,-1)
    DataInterval (0,15,Min,10)
    Average (1,TempC,FP2,False)
    Sample (1,RH,FP2)
EndTable

'Main Program (for sensor configured for 9600 baud, 8,1,none)
BeginProg

    SerialOpen (ComSDC7,9600,0,0,53)
```

```

'Strings to start serial output
String_1 = "SMODE RUN"+CRLF           'set SMODE to "RUN"
String_2 = "R"+CRLF                   'send "R" to start serial output

'Instructions to start serial output
SerialOut (ComSDC7,String_1,"RUN",3,100) 'send String_1, wait for 'RUN' response
Delay (0,500,mSec)
SerialOut (ComSDC7,String_2,"RH",3,100)  'send String_2

Scan (5,Sec,0,0)

'Get serial string from sensor
SerialInRecord (ComSDC7,SerialIndest,00,24,&H0D0A,NBytesReturned,00) '&H0D0A = CRLF
'Parse RH and temp from string
RH=Mid (SerialIndest,5,4)
TempC=Mid (SerialIndest,17,4)

CallTable Table1
NextScan
EndProg
    
```

The public variables for temperature and relative humidity can be viewed in the 'Numeric Display' mode as shown below.

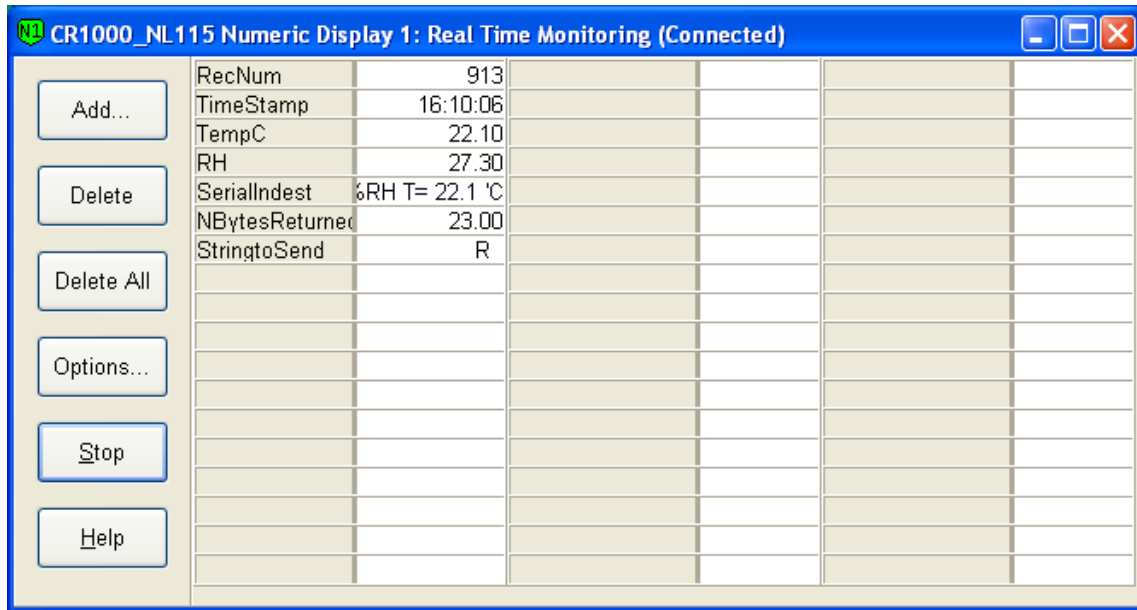

For troubleshooting purposes, the serial data buffer in the datalogger can be viewed using the 'W' terminal command. This is done by connecting to the datalogger from the 'Connect' button of Loggernet or PC400W. From the Connect screen, select Tools|Terminal Emulator. Click the 'Open Terminal' button, and hit the enter key to get the 'CR1000' prompt. Type 'W' for the 'Serial Comms Sniffer'. Select '4' for 'ComSDC7', and 'Y' for ASCII. Raw serial data received by the buffer is displayed on the screen as shown below.

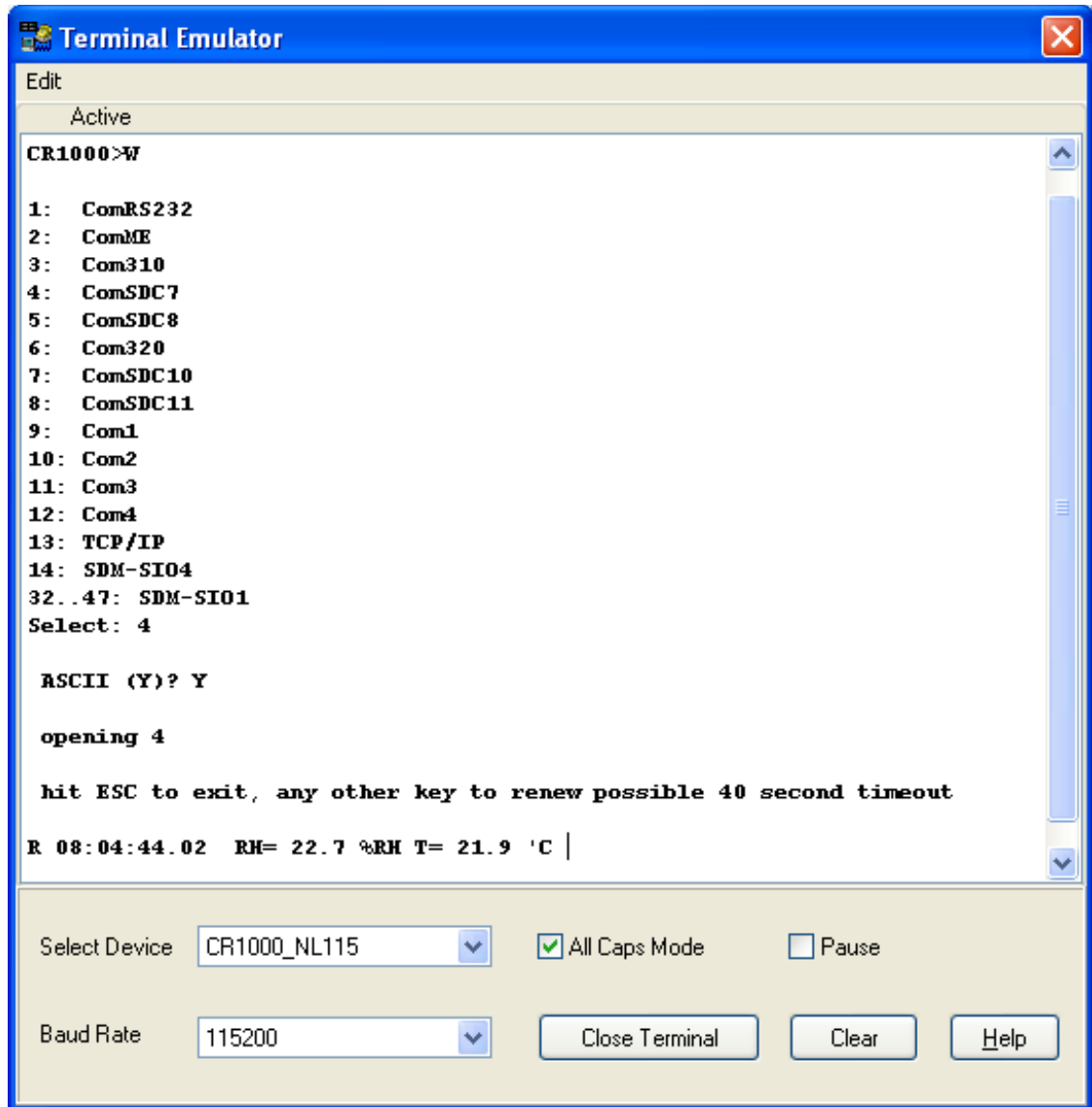





## **Campbell Scientific Companies**

---

### **Campbell Scientific, Inc. (CSI)**

815 West 1800 North  
Logan, Utah 84321  
UNITED STATES  
www.campbellsci.com • info@campbellsci.com

### **Campbell Scientific Africa Pty. Ltd. (CSAf)**

PO Box 2450  
Somerset West 7129  
SOUTH AFRICA  
www.csafrica.co.za • cleroux@csafrica.co.za

### **Campbell Scientific Australia Pty. Ltd. (CSA)**

PO Box 444  
Thuringowa Central  
QLD 4812 AUSTRALIA  
www.campbellsci.com.au • info@campbellsci.com.au

### **Campbell Scientific do Brazil Ltda. (CSB)**

Rua Luisa Crapsi Orsi, 15 Butantã  
CEP: 005543-000 São Paulo SP BRAZIL  
www.campbellsci.com.br • suporte@campbellsci.com.br

### **Campbell Scientific Canada Corp. (CSC)**

11564 - 149th Street NW  
Edmonton, Alberta T5M 1W7  
CANADA  
www.campbellsci.ca • dataloggers@campbellsci.ca

### **Campbell Scientific Centro Caribe S.A. (CSCC)**

300 N Cementerio, Edificio Breller  
Santo Domingo, Heredia 40305  
COSTA RICA  
www.campbellsci.cc • info@campbellsci.cc

### **Campbell Scientific Ltd. (CSL)**

Campbell Park  
80 Hathern Road  
Shepshed, Loughborough LE12 9GX  
UNITED KINGDOM  
www.campbellsci.co.uk • sales@campbellsci.co.uk

### **Campbell Scientific Ltd. (France)**

3 Avenue de la Division Leclerc  
92160 ANTONY  
FRANCE  
www.campbellsci.fr • info@campbellsci.fr

### **Campbell Scientific Spain, S. L.**

Avda. Pompeu Fabra 7-9, local 1  
08024 Barcelona  
SPAIN  
www.campbellsci.es • info@campbellsci.es

*Please visit [www.campbellsci.com](http://www.campbellsci.com) to obtain contact information for your local US or International representative.*