

ENC-Series

Weather-Resistant Enclosures



Campbell Scientific offers fiberglass-reinforced polyester enclosures for housing our dataloggers and peripherals. These non-corrosive, white enclosures are UV-stabilized and reflect solar radiation—reducing temperature gradients inside the enclosure without requiring a separate radiation shield. Dataloggers and peripherals housed in an enclosure with desiccant are protected from water and most pollutants.

The NEMA 4X enclosures (modified for cable entry) include a door gasket, external grounding lug, stainless steel hinge, and a lockable hasps. The enclosures are shipped with the 7363 enclosure supply kit that consists of desiccant, a humidity indicator card, cable ties, wire tie tabs, putty, grommets, screws, and PVC coupling. Additionally, Campbell Scientific offers a CS210 Enclosure Humidity Sensor for monitoring relative humidity inside of the enclosure.

Backplate

Dataloggers, peripherals, and brackets are mounted to an internal plate punched with a grid of one-inch-on-center holes. This mounting scheme simplifies system configuration and facilitates addition and removal of equipment in the field.

An internal backplate is included with each ENC10/12, ENC12/14, or ENC14/16 enclosure. Two internal mounting plate options are offered for the ENC16/18. The *-SB* option provides a backplate that is similar to the one included with the other enclosures. The *-EB* option provides both a backplate and sideplate. Photograph at right shows an ENC16/18 with the *-EB* option.

Models Available

ENC10/12

Campbell Scientific's ENC10/12 enclosure has internal dimensions of 10 x 12 x 4.5 in. (25.4 x 30.5 x 11.4 cm) and weighs 9.0 lb. (4.1 kg). It can house one CR200(X)-series datalogger, power supply, and one small peripheral. A CR800, CR850, or CR1000 can also be housed in the ENC10/12 if the #17565 stack mounting kit is used. For peripherals that are taller, an enclosure that has a raised lid is available; contact Campbell Scientific for more information.

ENC12/14

The ENC12/14 has internal dimensions of 12 x 14 x 5.5 in (30.5 x 35.6 x 14 cm). This enclosure can house one CR200(X)-series, CR800, CR850, CR1000, or CR3000 datalogger, power supply, and one or more peripherals (depending on the peripheral's footprint). It weighs 11.2 lb. (5 kg).

ENC14/16

This enclosure has internal dimensions of 14 x 16 x 5.5 in. (35.6 x 40.6 x 14 cm). The ENC14/16 can house one CR200(X)-series, CR800, CR850, CR1000, CR3000, or CR5000 datalogger, power supply, and one or more peripherals (depending on the peripheral's footprint).

ENC16/18

The ENC16/18, our largest enclosure, provides internal dimensions of 16 x 18 x 9 in (40.6 x 45.7 x 22.9 cm) and weighs 17 lb. (7.7 kg). It can house one CR200(X)-series, CR800, CR850, CR1000, CR3000, or CR5000 datalogger, power supply, and two or more peripherals (depending on the peripheral's footprint).



Mounting Bracket Options

Tripod

Order the *-MM* option if you want to mount your enclosure to the mast of one of our tripods or to a user-supplied pipe with a 1.25-in to 2.1-in OD. A three-piece bracket attaches to the top of the enclosure and an identical three-piece bracket attaches to the bottom of the enclosure (see illustrations at right). Each bracket is attached to the mast or pole via a 2-in u-bolt.

Tower

Order the *-TM* option if you want to mount your enclosure to a UT10, UT20, or UT30 tower. This mounting bracket option uses the same three-piece brackets as the *-MM* option, except the pieces are rearranged so that the flanges are on the side of the bracket instead of in the middle. Four 1.5-in u-bolts attach the brackets to the tower legs.

Please note that enclosures with the *-TM* option are shipped configured for the UT10 tower. UT20 and UT30 customers will need to: (1) remove the bolts attaching the bracket to the enclosure, (2) slide out the flange sections so that the distance between the center of each flange is 17 inches, and (3) reattach the bracket to the enclosure using the original bolts.

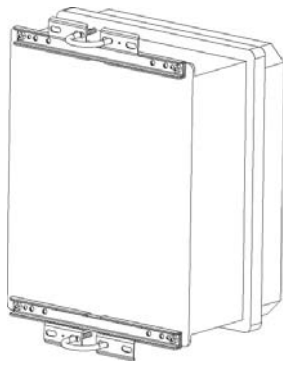

At left is an enclosure with the *-MM* mount option. The bracket is ready to be attached to a mast or user-supplied vertical pipe with a 1.25-in. to 2.1-in. outer diameter.

At right is an exploded view of the *-TM* option. It shows the bracket components and how the enclosure attaches to a tower.

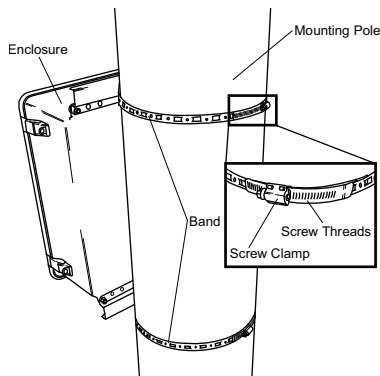
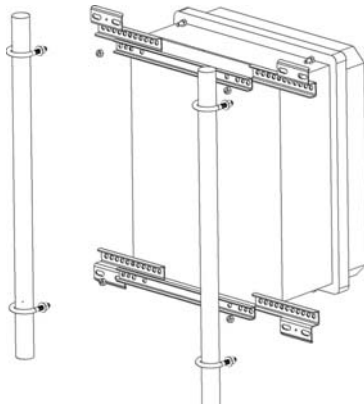

At left shows the *-PM* option, where the enclosure is mounted to a large diameter pole via band clamps.

Tripod Leg Base

Order the *-LM* option to mount the enclosure to the leg base of a CM106, CM110, CM115, or CM120 tripod; the ENC16/18 can only be mounted to the CM106's leg base. This option includes a metal flange, two brackets, and a 2.5-in u-bolt. The brackets attach to the right and left side of the enclosure, and the flange attaches to the tripod near the mast. The flange fits into a notch in one of the brackets, and the other bracket connects to a tripod leg via the u-bolt. Two enclosures may be mounted back-to-back on a leg base.

Large Diameter Pole

Order the *-PM* option to mount the enclosure to a large diameter pole such as a telephone pole. This option uses band clamps to secure the enclosure to the pole.

Special Brackets

Special brackets are also available for attaching enclosures to CTS Towers, Rohn Towers, Aluma Towers, or other non-Campbell Scientific instrument mounts. Contact Campbell Scientific for more information.

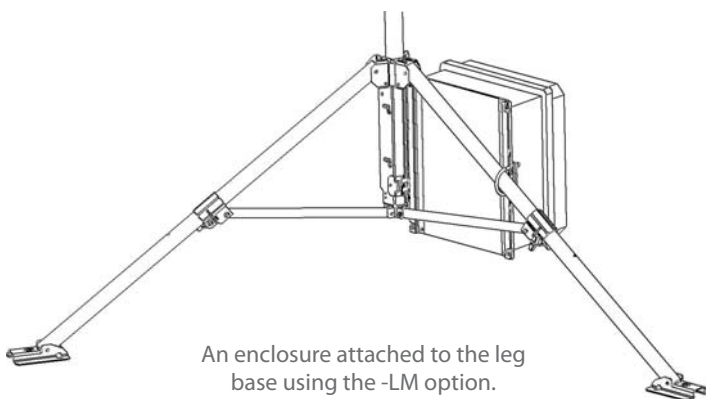

An enclosure attached to the leg base using the *-LM* option.

Cable-Entry Options

Conduit(s)

Multiple cables can be routed through one conduit. The -SC option provides one 1.5-in. diameter conduit; the -DC option provides two horizontally-arranged 1.5-in. diameter conduits; and the -VC option (ENC16/18 only) provides two vertically-arranged 1.5-in. diameter conduits. A plug included in the 7363 enclosure supply kit can reduce the conduit's internal diameter to 0.5 in. (1.3 cm). The enclosure supply kit also contains the putty used to seal each conduit.

Entry Seals (-ES Option)

Entry seals have a more water-tight seal than the conduits. With the -ES option, each entry seal is compressed around one cable. The seals contain a small vent to equalize pressure with the atmosphere. The number and size of seals provided depends on the enclosure model (see below):

ENC10/12: (1) **Medium** (fits 0.231 to 0.394 in. cables)
(2) **Small** (fits 0.118 to 0.275 in. cables)

ENC12/14: (2) **Medium** (fits 0.231 to 0.394 in. cables)
(2) **Small** (fits 0.118. to 0.275 in. cables)

ENC14/16: (2) **Large** (fits 0.236 to 0.512 in. cables)
(2) **Medium** (fits 0.231 to 0.394 in. cables)
(2) **Small** (fits 0.118 to 0.275 in. cables)

ENC16/18: (2) **Large** (fits 0.236 to 0.512 in. cables)
(2) **Medium** (fits 0.231 to 0.394 in. cables)
(2) **Small** (fits 0.118 to 0.275 in. cables)

Accessory Installations

Antenna Cable/Bulkhead

These accessories are offered for enclosures that will house a cellular phone, satellite transmitter, or radio. When ordered, Campbell Scientific will punch a special bulkhead hole in the enclosure and install a 17-in. antenna cable. Available antenna cable/bulkhead accessories are:

19335: Type N-to-RPSMA Antenna Cable for our RF401-series spread spectrum radios or CR200(X)-series dataloggers

19334: Type N-to-SMA Antenna Cable for the RF450 radio or RavenXT-series cellular modems

19332: Type N-to-Type N Antenna Cable for the RF310-series radios, TX320 GOES satellite transmitter, or FGR-115 radios

19336: Type SMA-to-SMA Antenna Cable for the GPS device used with satellite transmitters

19333: Type N-to-TNC Antenna Cable for our Raven100-series or Redwing100-series digital cellular modems

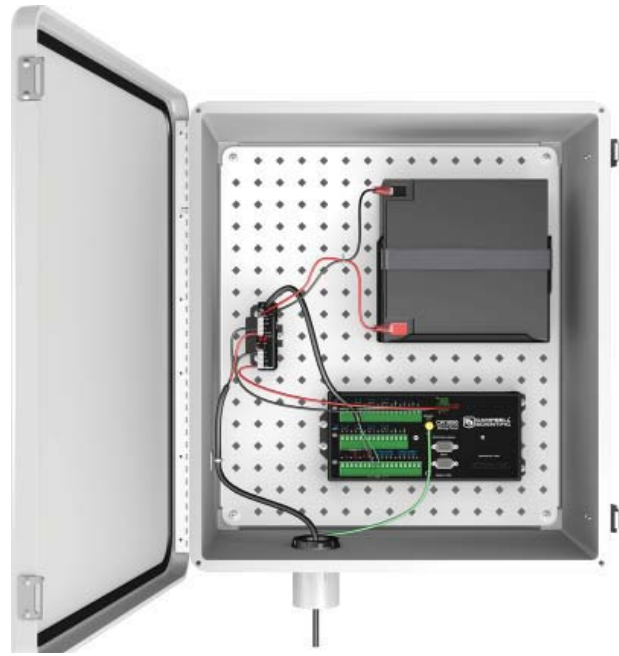

An enclosure with the -SC option includes one 1.5-in diameter port for cable entry. Shown is an ENC16/18 housing a CR1000 datalogger, CH200 Regulator, and BP24 battery pack.



An enclosure with the -DC option includes two horizontally-arranged 1.5-in diameter ports for cable entry (shown above).



An ENC16/18 with the -ES option has two small, two medium, and two large cable entry seals.



The CD100 has a vacuum fluorescent display for responsive use through a very wide operating temperature range. It has a water and dust ingress protection rating of IP66 when installed.

CD100 Mountable Display with Keypad

Specify #27814 to have Campbell Scientific install a CD100 in the enclosure door. The CD100 is an integrated keypad with display that mounts in an enclosure lid, which allows you to enter and view data without opening the enclosure. The CD100 provides the same operation and functionality as the CR1000KD, and is typically used with our CR800 and CR1000 dataloggers.

CD295 Data View II Display

Specify #18132 to have Campbell Scientific install a CD295 in the enclosure door. The CD295 is a two-line, 32-character LCD that is used with PakBus® dataloggers (i.e., CR200(X), CR800, CR850, CR1000, CR3000). When the CD295 is installed in an enclosure door, you can view real-time data on-site without opening the enclosure.



When a CD295 DataView II is installed in an enclosure door, you can view real-time data in the field without opening the enclosure.

CD294 Data View Display

Specify #16737 to have Campbell Scientific install a CD294 in the enclosure door. The CD294 is a two-line, 32-character LCD that is used with mixed-array dataloggers (e.g., CR510, CR10X). When the CD294 is installed in an enclosure door, you can view real-time data on-site without opening the enclosure.

Enclosure Door Switch Indicator

Specify #18166 to have Campbell Scientific install an enclosure door switch indicator or specify #18165 to have the customer install the indicator. This small accessory monitors when the door of the enclosure is open. It consists of an actuator and a magnetic switch—one is located on the case side, the other on the door side of the enclosure. The switch is monitored with a control port on the datalogger.



On the ENC10/12 and ENC12/14, the actuator (above left) for the door switch indicator is attached to the enclosure case and the switch (above right) is attached to the enclosure door. For the other enclosures, the actuator is attached to the door and the switch is attached to the case.