

INSTRUCTION MANUAL

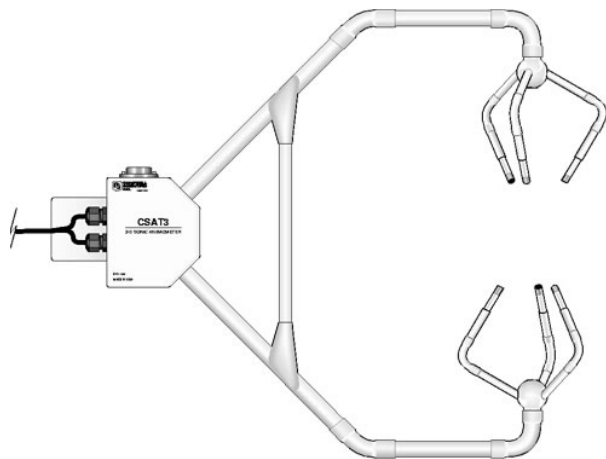

CSAT3 Three Dimensional Sonic Anemometer

Revision: 10/11



Copyright © 1998-2011
Campbell Scientific, Inc.

WARRANTY AND ASSISTANCE

This equipment is warranted by CAMPBELL SCIENTIFIC (CANADA) CORP. ("CSC") to be free from defects in materials and workmanship under normal use and service for **twelve (12) months** from date of shipment unless specified otherwise. **** **Batteries are not warranted.** **** CSC's obligation under this warranty is limited to repairing or replacing (at CSC's option) defective products. The customer shall assume all costs of removing, reinstalling, and shipping defective products to CSC. CSC will return such products by surface carrier prepaid. This warranty shall not apply to any CSC products which have been subjected to modification, misuse, neglect, accidents of nature, or shipping damage. This warranty is in lieu of all other warranties, expressed or implied, including warranties of merchantability or fitness for a particular purpose. CSC is not liable for special, indirect, incidental, or consequential damages.

Products may not be returned without prior authorization. To obtain a Return Merchandise Authorization (RMA), contact CAMPBELL SCIENTIFIC (CANADA) CORP., at (780) 454-2505. An RMA number will be issued in order to facilitate Repair Personnel in identifying an instrument upon arrival. Please write this number clearly on the outside of the shipping container. Include description of symptoms and all pertinent details.

CAMPBELL SCIENTIFIC (CANADA) CORP. does not accept collect calls.

Non-warranty products returned for repair should be accompanied by a purchase order to cover repair costs.



CAMPBELL SCIENTIFIC
C A N A D A C O R P .

11564 - 149 street - edmonton - alberta - T5M 1W7
tel 780.454.2505 fax 780.454.2655

www.campbellsci.ca

PLEASE READ FIRST

About this manual

Please note that this manual was originally produced by Campbell Scientific Inc. (CSI) primarily for the US market. Some spellings, weights and measures may reflect this origin.

Some useful conversion factors:

Area: 1 in² (square inch) = 645 mm²

Length: 1 in. (inch) = 25.4 mm
1 ft (foot) = 304.8 mm
1 yard = 0.914 m
1 mile = 1.609 km

Mass: 1 oz. (ounce) = 28.35 g
1 lb (pound weight) = 0.454 kg

Pressure: 1 psi (lb/in²) = 68.95 mb

Volume: 1 US gallon = 3.785 litres

In addition, part ordering numbers may vary. For example, the CABLE5CBL is a CSI part number and known as a FIN5COND at Campbell Scientific Canada (CSC). CSC Technical Support will be pleased to assist with any questions.

CSAT3 Table of Contents

PDF viewers: These page numbers refer to the printed version of this document. Use the PDF reader bookmarks tab for links to specific sections.

1. General	1
2. Specifications	1
2.1 Measurements	1
2.2 Output Signals	2
2.3 Physical Description	3
2.4 Power Requirements	4
3. Initial Setup	4
3.1 Factory Settings	4
3.2 SDM Address	5
4. Installation	5
4.1 Orientation	5
4.2 Mounting	6
4.3 Leveling	8
4.4 Fine Wire Thermocouple	8
5. Wiring	8
6. CSAT3 Outputs	10
6.1 SDM Output	11
6.1.1 CRBasic Dataloggers	12
6.1.2 EDLOG Dataloggers	12
6.1.3 CR9000	12
6.2 RS-232 Output	12
6.3 Analog Output	12
7. Operational Principles	13
7.1 Embedded Code Version 4	13
7.2 Embedded Code Version 3	13
7.3 Effects of Crosswind on the Speed of Sound	15
8. CSAT3 Trigger	15
8.1 Sampling Modes	17
8.1.1 Single-Measurement Mode	17
8.1.2 Oversample Mode	17

9. Data Pipeline Delay	18
10. Datalogger Programming using SDM	18
10.1 CRBasic CSAT3 () Instruction	18
10.2 EDLOG SDM-CSAT3 (P107) Instruction.....	19
10.3 Datalogger Instruction Parameters.....	19
10.4 Diagnostic Word	21
10.5 SDMTrigger ()/SDM-Group Trigger (P110).....	23
10.6 Example CRBasic Datalogger Program.....	23
10.7 Example EDLOG Datalogger Program	28
11. Maintenance	37
11.1 Wicks	38
11.2 Calibration.....	39
11.2.1 Cold Shifted Calibration.....	39
11.2.2 Test for Wind Offset	40
12. Select Backdoor Commands	42
 <i>Appendices</i>	
A. CSAT3 Orientation	A-1
A.1 Determining True North and Sensor Orientation.....	A-1
A.2 Online Magnetic Declination Calculator.....	A-3
B. Serial Communications with the CSAT3	B-1
B.1 CSAT3 RS-232 Commands	B-1
B.2 CSAT3 Binary Data Output Format.....	B-3
B.3 Words 0 through 3.....	B-4
B.4 Word 4.....	B-5
B.5 CSAT3 RS-232 Status Format	B-5
C. CSAT3 Measurement Theory.....	C-1
C.1 Theory of Operation	C-1
C.1.1 Wind Speed	C-1
C.1.2 Temperature.....	C-1
D. SDM Communications and Long Signal Cables... D-1	
D.1 Brief Description of SDM Clock Rates.....	D-1
D.2 CR3000 Example	D-2
D.3 CR23X Example	D-2

Figures

1. CSAT3 Coordinate System and Captive Mounting Hardware6

2. CSAT3 Coordinate System, and Captive Mounting Hardware and Cup Washer7

3. CSAT3 Coordinate System and Original Noncaptive Mounting Hardware7

4. Typical Average CSAT3 Current Drain at +12 VDC.....16

5. CSAT3 Pipeline Delay17

6. Proper Location of the Top and Bottom Wicks.....38

7. CSAT3 running at 1 Hz and successfully communicating with the CSAT3.....40

8. Recommended Settings for the Wind Vertical Axis.....41

9. Recommended Settings for the Wind Vertical Axis Labels41

10. Wind Data from CSAT3 s/n 315; Wind Offsets within Specifications at 19°C42

A-1. Magnetic Declination for the Conterminous United States A-1

A-2. A Declination Angle East of True North (Positive) is Subtracted from 360 (0) degrees to Find True North A-2

A-3. A Declination Angle West of True North (Negative) is Subtracted from 0 (360) degrees to Find True North A-2

A-4. USGS Web Calculator..... A-3

B-1. PC as the Trigger SourceB-3

B-2. CSAT3 as the Trigger Source.....B-3

Tables

1. SDM Addressing Scheme.....5

2. CSAT3 Power.....9

3. CSAT3 SDM Output to a CR3000, CR5000, and CR9000X Datalogger ..9

4. CSAT3 SDM Output to a CR1000, CR800/850, CR23X and CR10(X) datalogger9

5. CSAT3 SDM Output to a 21X Datalogger.....9

6. CSAT3 SDM Output to a CR9000 Datalogger9

7. CSAT3 RS-232 Output Pin Out10

8. CSAT3 Analog Output Wiring.....10

9. FW05/FWC-L35 Fine Wire Thermocouple10

10. CSAT3 Outputs11

11. SDM Compatible Dataloggers.....11

12. Calibration for Analog Outputs13

13. CSAT3 () Instruction Parameters18

14. SDM-CSAT3 (P107) Instruction Parameters19

15. CR3000, CR1000, CR5000, CR800/850, CR9000(X), CR23X, and 21X Execution Interval and CSAT3 Execution Parameter.....21

16. CR10(X) Execution Interval and CSAT3 Execution Parameter.....21

17. Diagnostic Word.....22

18. CSAT3 Diagnostic Flags23

19. Wiring for Program Example 123

20. Wiring for Program Example 228

B-1. RS-232 Command CodesB-2

B-2. RS-232 Output.....B-4

B-3. Converting u_x Wind from Word 0B-4

B-4. Converting u_y Wind from Word 1B-4

B-5. Converting u_z Wind from Word 2B-4

B-6. Converting Speed of Sound from Word 3B-5

- B-7. Decoding the Diagnostic Flags from Word 4 B-5
- B-8. Special Case – Not a Number B-5
- B-9. RS-232 Status, Response to the S or P Command B-6
- D-1. Data from Example CR3000 SDM Clock Rate Search Program..... D-2
- D-2. Data from Example CR23X SDM Clock Rate Search Program..... D-3
- D-3. SDM Clock Rate Report..... D-3

CSAT3 Three Dimensional Sonic Anemometer

1. General

The CSAT3 is an ultrasonic anemometer for measuring wind speed in three dimensions. It uses three pairs of non-orthogonally oriented transducers to sense the horizontal wind. Each pair of transducers transmits and receives the ultrasonic signal. The time of flight is directly related to the wind speed along the sonic transducer axis. The speed of sound is directly related of the air density, e.g. temperature and humidity.

The CSAT3 can be used to measure average horizontal wind speed and direction or turbulent fluctuations of horizontal and vertical wind. From the turbulent wind fluctuations, momentum flux is calculated. By finding the covariance between vertical wind and scalars, sensible, latent heat, carbon dioxide flux is directly be measured.

The sonic transducers are sealed and will not be damaged should they become wet. The CSAT3 will continue to make wind measurements under rainy conditions; however, like all ultrasonic anemometers, should the transducers be sufficiently obscured, the CSAT3 will be unable to make further measurements.

The CSAT3 can be measured using SDM (Synchronous Device for Measurements) communications and a Campbell Scientific, Inc. datalogger. All Campbell Scientific dataloggers that support the CSAT3 SDM instruction do so without a special operating system with the exception of the 21X and CR10, see Table 11 for compatible dataloggers.

The fine wire thermocouple used with the CSAT3 is the FW05. It is a 0.0005” diameter thermocouple mounted on a stainless steel bayonet. A FWC-L35 cable is required with the FW05. Four feet of the FWC-L35 is bundled inside the enclosure to minimize conduction of heat into the terminal strips. The remaining 31 feet permits mounting the FW05 to the side of the CSAT3 head. Finally, the thermocouple cover (p/n 10080) is placed over the connectors. This cover is used to mount the connectors to the side of the CSAT3 head and minimize the temperature gradient across the omega brand connectors.

2. Specifications

2.1 Measurements

The CSAT3 measures wind speed and the speed of sound along the three non-orthogonal sonic axes. The wind speeds are then transformed into the orthogonal wind components u_x , u_y , and u_z and are referenced to the anemometer head; the reported speed of sound (c) or sonic virtual temperature (T_s), is the average between the three non-orthogonal sonic axes. The errors caused by wind blowing normal to the sonic path are corrected online before the wind speed is transformed into orthogonal coordinates. It is not necessary

to apply the speed of sound correction described by Liu et al., 2001. The CSAT3 can be configured to make a single measurement per trigger or multiple measurements that are centered around the trigger (oversampled).

OUTPUTS: u_x , u_y , u_z , and c (u_x , u_y , u_z , are orthogonal wind components referenced to the anemometer head; c is the speed of sound)

SPEED OF SOUND: determined from 3 acoustic paths; corrected for crosswind effects

MEASUREMENT RATE: programmable from 1 to 60 Hz, instantaneous measurements; two oversampled modes are block averaged to either 20 Hz or 10 Hz

MEASUREMENT RESOLUTION: u_x and u_y are 1 mm s^{-1} rms; u_z is 0.5 mm s^{-1} rms; c is 15 mm s^{-1} (0.025°C) with embedded code version 4 (standard) [c is 1 mm s^{-1} (0.002°C) with embedded code version 3]. Values are the standard deviations of instantaneous measurements made of a constant signal. The noise is unaffected by the sample rate.

OPERATING TEMPERATURE RANGE: -30° to 50°C (standard); -40° to 40°C (cold shifted)

ACCURACY (-30° to 50°C and -40° to 40°C operating range; wind speed $< 30 \text{ m s}^{-1}$; azimuth angles between $\pm 170^\circ$):

Offset Error:

$u_x, u_y:$	$< \pm 8 \text{ cm s}^{-1}$
$u_z:$	$< \pm 4 \text{ cm s}^{-1}$

Gain Error:

Wind vector within $\pm 5^\circ$ of horizontal	$< \pm 2$ percent of reading
Wind vector within $\pm 10^\circ$ of horizontal	$< \pm 3$ percent of reading
Wind vector within $\pm 20^\circ$ of horizontal	$< \pm 6$ percent of reading

2.2 Output Signals

The CSAT3 can output data to a data retrieval system using any of the following communications: SDM (Synchronous Device for Measurement), RS-232, or analog output. All the output signals have a two scan delay.

DIGITAL SDM: A Campbell Scientific, Inc. 33300 bps serial interface for datalogger/sensor communication

Data type: 2-byte integer per output plus 2-byte diagnostic and 2-byte configuration parameter

DIGITAL RS-232: Baud rate: 9600 bps or 19200 bps

Data type: 2-byte integer per output plus 2-byte diagnostic

ANALOG: Number of outputs: 4

Voltage range: $\pm 5 \text{ V}$

Number of bits: 12

REPORTING RANGE:

SDM and RS-232 digital Outputs:

Full scale wind: $\pm 65.535 \text{ m s}^{-1}$ autoranging between four ranges; least significant bit is $0.25 \text{ to } 2 \text{ mm s}^{-1}$

Speed of sound: $300 \text{ to } 366 \text{ m s}^{-1}$ ($-50^\circ \text{ to } +60^\circ\text{C}$); least significant bit is 1 mm s^{-1} (0.025°C embedded code version 4; 0.002°C embedded code version 3)

ANALOG OUTPUTS:

<u>Output</u>	<u>Range</u>	<u>LSB</u>
u_x, u_y	$\pm 32.768 \text{ m s}^{-1}$	15 mm s^{-1}
	$\pm 65.536 \text{ m s}^{-1}$	30 mm s^{-1}
u_z	$\pm 8.192 \text{ m s}^{-1}$	4 mm s^{-1}
c	$300 \text{ to } 366 \text{ m s}^{-1}$ ($-50^\circ \text{ to } +60^\circ\text{C}$)	16 mm s^{-1} (0.026°C)

2.3 Physical Description

MEASUREMENT PATH LENGTH: 10.0 cm vertical; 5.8 cm horizontal

TRANSDUCER PATH ANGLE FROM HORIZONTAL: 60 degrees

TRANSDUCER: 0.64 cm (0.25 in) diameter

TRANSDUCER MOUNTING ARMS: 0.84 cm (0.33 in) diameter

SUPPORT ARMS: 1.59 cm (0.63 in) diameter

DIMENSIONS:

Anemometer Head: 47.3 cm (l) x 42.4 cm (h) (18.6 in x 16.7 in)

Electronics Box: 26 cm x 16 cm x 9 cm (10.2 in x 6.3 in x 3.5 in)

Carrying Case: 71.1 cm x 58.4 cm x 33 cm (28 in x 23 in 13 in)

WEIGHT:

Anemometer Head: 1.7 kg (3.7 lb)

Electronics Box: 2.8 kg (6.1 lb)

Shipping: 16.8 kg (37 lb)

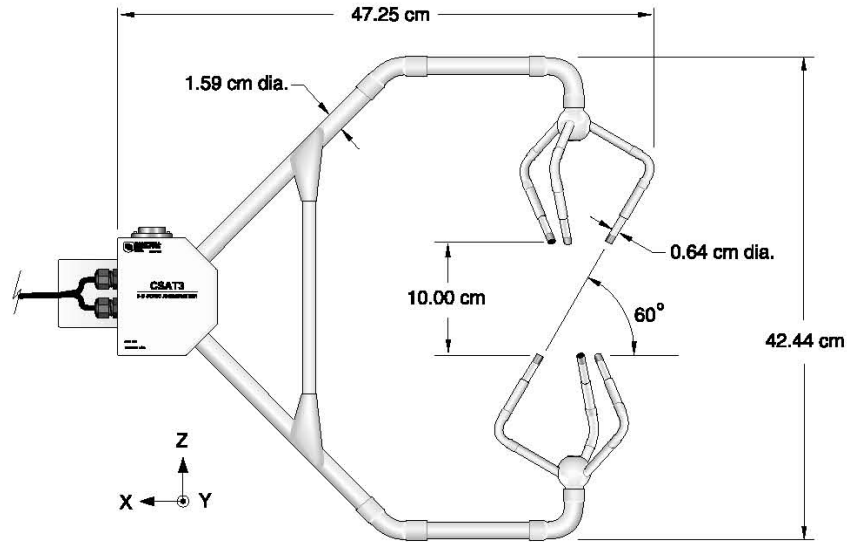

Anemometer Head

2.4 Power Requirements

VOLTAGE SUPPLY: 10 to 16 Vdc

POWER:

2.4 W @ 60 Hz measurement frequency

1.2 W @ 20 Hz measurement frequency

3. Initial Setup

3.1 Factory Settings

- Analog Outputs – Off
- Execution Parameter – 10 Hz (see Section 10.3 and B.1)
- Trigger Source – Internal Clock (see Section 8, 9, and B.1)
- SDM Address – 3 (see Section 3.2, 6.1, and 10.3)
- RS-232 baud rate – 9600 bps (RS=0) (see Section 12 and Appendix B)
- Software RTS – Off (RI=0) (see Section 12 and Appendix B)
- Unprompted Output – Off (&=0) (see Appendix B)

The above settings can be changed with a PC, running the CSAT3 PC support software (CSAT32.EXE), and the RS-232 cable. A copy of the CSAT3 PC support software is available from the Campbell Scientific web site in the Support/Downloads section.

3.2 SDM Address

Each CSAT3 on the SDM bus must have a unique address. A hex thumb switch within the electronics box is used to change the SDM address. Remove the lid and orient the electronics box with the connectors pointing down. The hex thumb switch is now located in the lower right hand side of the electronics box (see Table 1 for SDM addresses).

CAUTION **SDM address F (hex) is a special address used during a Group Trigger. Do not set the hex thumb switch to SDM address F on the CSAT3's CPU board.**

TABLE 1. SDM Addressing Scheme

CRBasic Datalogger Address (base 10)	EDLOG Datalogger Address (base 4)	CSAT3 Thumb Switch (hexadecimal)
0	00	0
1	01	1
2	02	2
3	03	3
4	10	4
5	11	5
6	12	6
7	13	7
8	20	8
9	21	9
10	22	A
11	23	B
12	30	C
13	31	D
14	32	E

4. Installation

4.1 Orientation

The three components of wind are defined by a right handed orthogonal coordinate system. The CSAT3 points into the negative x direction (see Figure 1). If the anemometer is pointing into the wind, it will report a positive u_x wind.

In general, point the anemometer into the prevailing wind to minimize the amount of data that is contaminated by the anemometer's arms and other supporting structures.

4.2 Mounting

The sonic anemometer is mounted to a vertical 3/4" diameter US bore pipe with a 3/4" by 3/4" crossover fitting (p/n 1017). The fitting is included with the CSAT3. The fitting will accommodate up to a 1" outside diameter pipe.

CAUTION Do not carry the CSAT3 by the arms or the strut between the arms. Always hold the CSAT3 by the block, where the upper and lower arms connect.

Attach the crossover fitting to the vertical pipe and lightly tighten the vertical set screws. Insert the horizontal mounting arm into the crossover fitting and lightly tighten the horizontal set screws. Point the horizontal arm into the prevailing wind. Tighten all the fitting set screws. Mount the anemometer head to the horizontal arm. Lightly tighten the bolt underneath the anemometer block (see Figure 1, 2, and 3).

CAUTION Over-tightening bolts will damage or deform the mounting hardware.

Attach the electronics box to the body of the tripod. Use a 1/2" wrench to tighten the nuts. Connect the cable from the anemometer head to the connector on the electronics box labeled Transducer Head.

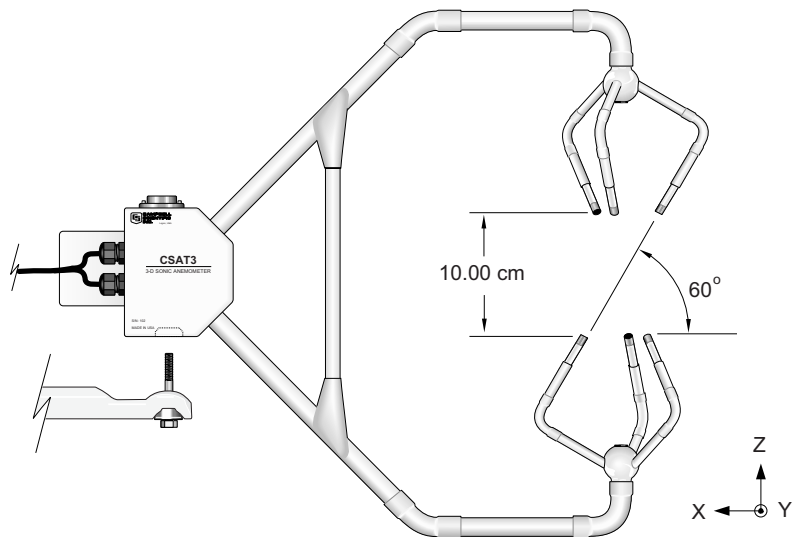

FIGURE 1. CSAT3 Coordinate System and Captive Mounting Hardware (s/n 0631 to current)

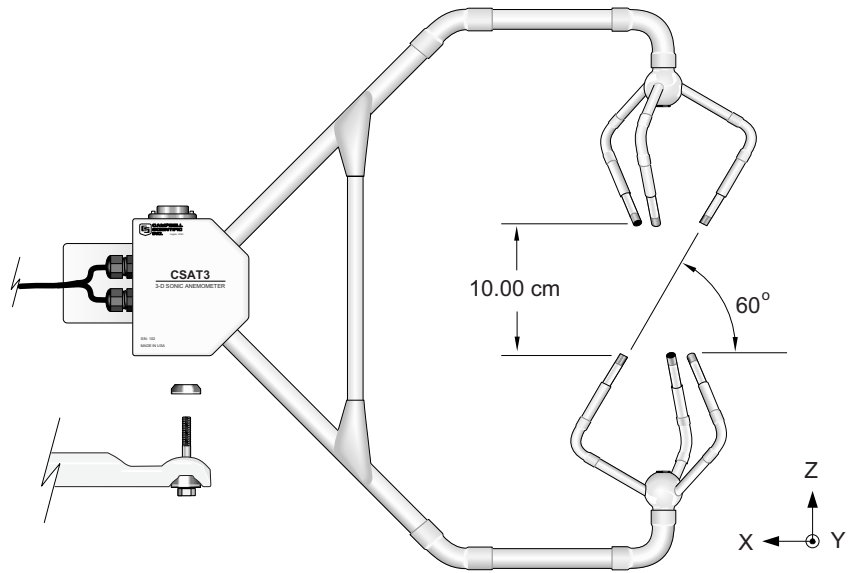

FIGURE 2. CSAT3 Coordinate System, and Captive Mounting Hardware and Cup Washer (s/n 0107 to 0630)

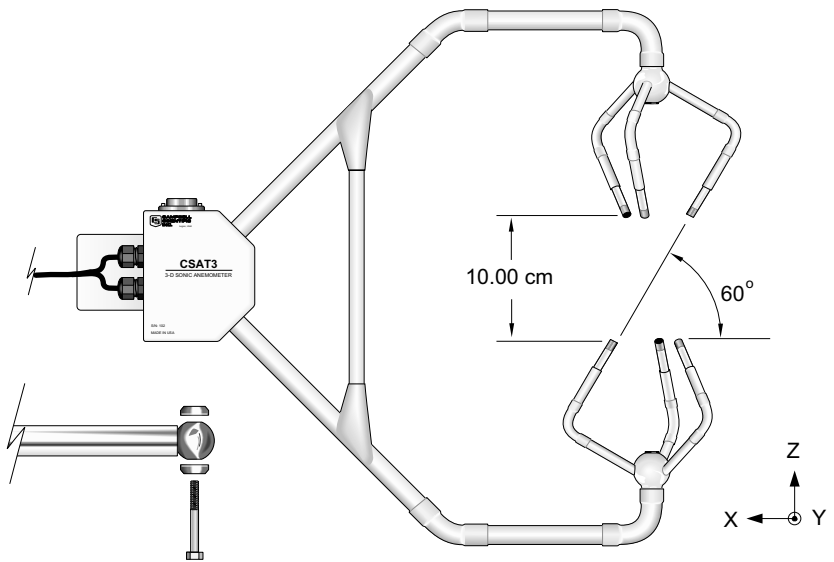

FIGURE 3. CSAT3 Coordinate System and Original Noncaptive Mounting Hardware (s/n 0107 to 0630)

4.3 Leveling

Over flat level terrain, adjust the anemometer head so that the bubble within the level is in the bullseye. Over sloping terrain, adjust the anemometer head so that the horizontal surface that the bubble level is mounted on is parallel to the terrain. Firmly grasp the sonic anemometer block, loosen the bolt underneath the block, and adjust the head accordingly. Finally, tighten the bolt with a 9/16" wrench.

4.4 Fine Wire Thermocouple

A fine wire thermocouple (model FW05 and FWC-L35) can be mounted to the side of the anemometer block to measure temperature fluctuations. Attach the female connector from the FWC-L35 to the side of the anemometer with the short screw (#2-56 0.437", p/n 3514) that was provided with the thermocouple cover. Insert the male connector of the FW05 into the female connector of the FWC-L35. Finally, attach the thermocouple cover to the anemometer block, using the thumb screw, so that both the FW05 and FWC-L35 connectors are covered.

5. Wiring

There are four military style connectors on the CSAT3 electronics box. They are labeled as +12V SDM, RS-232, Transducer Head, and Analog Output. Connect the cable from the anemometer head to the electronics box labeled Transducer Head. The anemometer head cable is 2.13 m (7 ft) in length. Each of the signal cables is 7.62 m (25 ft) in length. Connect the appropriate signal cable to the electronics box. See the Tables 2 through 9 for details on the wire color scheme.

CAUTION **The CSAT3 electronics box contains unique calibration information for its respective sensor head. Do not mismatch CSAT3 sensor heads and electronics. Doing so will result in erroneous wind and speed of sound measurements.**

NOTE Before extending the SDM signal cable, read Appendix D.

NOTE Short haul modems, wire or fiber optic, may be used to lengthen the RS-232 communications cable. Short haul modems do not include an RTS signal. The CSAT3's RS-232 drivers can be asserted by a software setting in the CSAT3. This setting will always power the RS-232 drivers, independent of the RTS line.

Spark gaps (model 6536 and 6361) may be required to protect against transients when using wire short haul modems. Spark gap protection is not needed with fiber optic short haul modems.

TABLE 2. CSAT3 Power			
Battery Terminal	Description	Color	Pin
Positive	12 Vdc	Red	A
Negative	Power Reference	Black	B

TABLE 3. CSAT3 SDM Output to a CR3000, CR5000, and CR9000X Datalogger			
Channel	Description	Color	Pin
SDM-C1	SDM Data	Green	D
SDM-C2	SDM Clock	White	C
SDM-C3	SDM Enable	Brown	E
G	Digital Ground	Black	F
G	Shield	Clear	nc

TABLE 4. CSAT3 SDM Output to a CR1000, CR800/850, CR23X and CR10(X) Datalogger			
Channel	Description	Color	Pin
C1	SDM Data	Green	D
C2	SDM Clock	White	C
C3	SDM Enable	Brown	E
G	Digital Ground	Black	F
G	Shield	Clear	nc

TABLE 5. CSAT3 SDM Output to a 21X Datalogger			
Channel	Description	Color	Pin
1H	SDM Data	Green	D
C1	10 K resistor to 1H		
C2	SDM Clock	White	C
C3	SDM Enable	Brown	E
⊕	Digital Ground	Black	F
⊕	Shield	Clear	nc

TABLE 6. CSAT3 SDM Output to a CR9000 Datalogger			
CR9000 9080 DB9 Pin	Datalogger Description	Color	Pin
8	SDM Data	Green	D
7	SDM Clock	White	C
6	SDM Enable	Brown	E
2	Digital Ground	Black/Clear	F/nc

TABLE 7. CSAT3 RS-232 Output Pin Out				
CSAT3 (DCE) DB9 Pin		PC (DTE) DB9 Pin	Color	Pin
2 (TxD)	→	2 (RxD)	Red	B
3 (RxD)	←	3 (TxD)	White	C
5 (gnd)		5 (gnd)	Green	E
7 (CTS)	←	7 (RTS)	Brown	G
8 (RTS)	→	8 (CTS)	Black	H

TABLE 8. CSAT3 Analog Output Wiring		
Description	Color	Pin
u _x sig high	Brown	A
u _x sig low	Black	E
u _y sig high	Red	B
u _y sig low	Black	E
u _z sig high	Green	C
u _z sig low	Black	E
c sig high	White	D
c sig low	Black	E
shield	Clear	nc

TABLE 9. FW05/FWC-L35 Fine Wire Thermocouple	
Description	Color
Signal High	Purple
Signal Low	Red

6. CSAT3 Outputs

The CSAT3 has three signal outputs: SDM, RS-232, and analog. Campbell Scientific recommends that the SDM output be used when ever possible, followed by RS-232, and finally analog. Table 10 summarizes the difference between the three output options. In general SDM communications has the following advantages: lowest CSAT3 current drain, best control and diagnostics, and highest data resolution.

	SDM	RS-232	Analog
Typical Current Drain @ 10 Hz	51 mA @ 12 Vdc	89 mA @ 12 Vdc	99 mA @ 12 Vdc
External Trigger Source	yes	yes	no
Output Dynamic Range	19 bit	19 bit	12 bit
Diagnostics Available	yes	yes	no

6.1 SDM Output

SDM is a Campbell Scientific communication protocol used between a Campbell Scientific datalogger and a smart sensor. Table 11 lists all the Campbell Scientific dataloggers that support SDM communications, along with the required datalogger OS/PROM and CSAT3 embedded code.

Datalogger Model	Datalogger PROMs or Operating System (OS)	Requires CSAT3 embedded code
21X 1K	6145-3, 6146-5, 10006-1	2.1 or >
21X 2K	6148-5, 6149-7, 6070-64	2.1 or >
CR10 2K	5954-396	2.1 or >
CR10 4K	Library Special	2.1 or >
CR10X	OS 1.4 or >	2.1 or >
CR23X	All OS	2.1 or >
CR9000	2.01 or >	2.1 or >
CR5000	All OS	3.0 or >
CR9000X	All OS	3.0 or >
CR1000	All OS	3.0 or >
CR3000	All OS	3.0 or >
CR800/850	All OS	3.0 or >

6.1.1 CRBasic Dataloggers

SDM is a Campbell Scientific communication protocol used between a Campbell Scientific datalogger and a smart sensor. This protocol uses SDM dedicated control ports (CR3000, CR5000, and CR9000X) or multipurpose control ports (CR1000, CR800/850) to communicate with the CSAT3. SDM protocol allows synchronized measurement and rapid communication between a datalogger and the CSAT3. The CRBasic datalogger instruction, CSAT3 () is used to communicate with the CSAT3 over the SDM bus.

6.1.2 EDLOG Dataloggers

SDM is a Campbell Scientific communication protocol used between a Campbell Scientific dataloggers and a smart sensor. This protocol uses SDM dedicated control ports (CR23X) or multipurpose control ports (21X or CR10(X)) to communicate with the CSAT3. With a 21X, single ended analog input channel 1 (labeled 1H) and a 10 K resistor is used in conjunction with control port 1. SDM protocol allows synchronized measurement and rapid communication between a datalogger and the CSAT3. The EDLOG datalogger instruction, SDM-CSAT3 (P107), is used to communicate with the CSAT3 over the SDM bus.

6.1.3 CR9000

SDM communications between the CR9000 and CSAT3 is achieved via the 9 pin CSI serial I/O port on the 9080 peripheral and memory card. The CR9000 instruction CSAT3() is used to communicate with the CR9000 over the SDM bus.

6.2 RS-232 Output

The Windows PC support software (CSAT32.EXE) can be used to graph the CSAT3 data in real time or collect time series via the RS-232 serial port. A copy of the CSAT3 PC software is available from the Campbell Scientific web site in the Support|Downloads section. This software is intended as a diagnostic tool, rather than part of a long term data acquisition system.

Appendix B contains detailed information on the CSAT3 RS-232 commands. An example of an elementary Visual Basic program to configure and collect data from a CSAT3 is available from the Campbell Scientific web site in the Support|Downloads section.

6.3 Analog Output

The anemometer can be programmed to output four analog signals that correspond to u_x , u_y , u_z , and c . These signals range ± 5000 mV. The analog output is enabled using the Windows CSAT3 PC support software (CSAT32.EXE) using the PC's and CSAT3's RS-232 serial port. The u_x and u_y components of wind have two output ranges, low range (± 32.768 m s⁻¹) and high range (± 65.536 m s⁻¹). These ranges are changed using the support software. Low range is adequate to measure wind speeds ± 32.768 m s⁻¹. Table 12 gives the multipliers and offset for all the anemometer outputs in m s⁻¹.

TABLE 12. Calibration for Analog Outputs

	Slope Low Range ($\text{m s}^{-1} \text{V}^{-1}$)	Slope High Range ($\text{m s}^{-1} \text{V}^{-1}$)	Offset (m s^{-1})
u_x	6.5536	13.1072	0
u_y	6.5536	13.1072	0
u_z	1.6384	1.6384	0
c	6.5536	6.5536	340

When analog outputs are used, the anemometer uses its internal timer to trigger the wind measurements. Thus, the wind measurements can be skewed in time $\pm 1/2$ the data acquisition system's scan interval from other analog measurements, e.g. temperature or humidity. Recall that the CSAT3 analog outputs also have a two measurement pipeline delay.

7. Operational Principles

7.1 Embedded Code Version 4

The CSAT3 measures wind speeds and the speed of sound by determining the time of flight of sound between pairs of transducers, as described in Appendix C. However, unlike many other commercial anemometers, it does not use simple threshold detection to determine the ultrasonic times of flight. Instead, it uses advanced digital signal processing techniques to determine the arrival of the transmitted ultrasonic signal. In comparison to other systems, the digital signal processing techniques result in more accurate, lower noise measurements.

Unlike CSAT3s running embedded code version 3, embedded code version 4 does not use a library of calibration templates and pattern recognition to determine the ultrasonic time of flight. Embedded code versions 4 and 3 have the same wind resolution. The resolution of the speed of sound measurement using embedded code version 4 is 15 times worse than embedded code version 3 (0.002°C to 0.025°C RMS); however, the resolution of the speed of sound measurement is still a factor of two better compared to any other commercially available sonic anemometer.

Field comparisons of measurements made with a CSAT3 anemometer containing embedded code version 4 and one containing embedded code version 3 show that the new algorithm significantly improves the anemometer's ability to obtain measurements under conditions of low signal to noise ratio, e.g. during rain events. Additionally, the water wicks installed on the CSAT3 transducers contribute to improved performance during rain events by preventing large drops from accumulating on the transducer faces.

7.2 Embedded Code Version 3

The CSAT3 measures wind speeds and the speed of sound by determining the time of flight of sound between pairs of transducers, as described in Appendix C. However, unlike many other commercial anemometers, it does not use simple threshold detection to determine the ultrasonic times of flight. Instead,

it uses advanced digital signal processing techniques and pattern recognition algorithms which, in comparison to other systems, results in more accurate, lower noise measurements. The pattern recognition algorithms allow the system to quickly detect and indicate a degradation of signal quality and system performance. As a consequence, a CSAT3 running embedded code version 3 was highly sensitive to rain droplets on the transducers faces.

WARNING

Placing wicks on a CSAT3 running embedded code version 3 will not improve the CSAT3s performance in the rain. The wicks prevent large drops of water that completely obscure the sonic signals from accumulating on the transducer faces and are part one of a two part solution in operating in rainy conditions. The second part is in the digital signal processing in embedded code version 4.

The CSAT3 signal processing techniques result in slight differences in operation when compared to simpler sonic anemometers. These differences include a start-up delay before the system is fully functional plus a requirement for the correct triggering of the sensor to ensure a constant flow of synchronized data. The general principles of operation are described in the following section.

After the CSAT3 transmits an ultrasonic signal from one of its transducers, it records the received signal from the opposing transducer. To optimize system performance, the CSAT3 only looks for the received signal during a limited window in time. The exact start and end times of the window is determined not only by the spacing between transducers but also by the current wind speed and speed of sound conditions.

After power-up or loss of signal, the CSAT3 enters a mode where it tests the forward and return paths for each of the pairs of ultrasonic transducers. This is called the “acquire” mode and takes about 10 seconds before normal output is available from the anemometer. This delay is caused in part because the anemometer has no recent knowledge of the responses of the transducer pairs and in particular no past history of the wind speed and speed of sound. During this acquire mode, it has to search across quite wide windows in time to find the true arrival time of each received signal.

Once it has acquired the signal, it uses a tracking algorithm to adjust the start and end times of its search window based both on the Execution Parameter (see Section 10.3) and the last measured ultrasonic time of flight. The basis of this adjustment is that the dynamics of air movement prevent the time of flight changing by more than a certain amount in a given time. The result of using this algorithm is that the width of this window in time can be kept to a minimum and measurements can be made at a higher frequency for an overall lower consumption of power when compared to using wider fixed windows.

Because the Execution Parameter is used as an important input to the tracking algorithm it must be set to match the frequency at which the anemometer is triggered. The setting of this parameter and matching it to the trigger frequency are discussed in Section 8.

7.3 Effects of Crosswind on the Speed of Sound

The speed of sound is found by combining the out and back time-of-flight measurements (see Eq. 5 in Appendix C). The parallel component of the wind along the sonic axis does not affect the measured speed of sound, however, the perpendicular component does. The effects of the perpendicular component of wind can be accounted for online, using the measured components of wind and simple trigonometry, or off-line using methods described by Schotanus et al., 1983 and Liu et al., 2001. The CSAT3 has always corrected for the effects of crosswind on the speed of sound, and as of the printing of this manual, the CSAT3 is the only commercially available sonic anemometer that corrects the speed of sound, and ultimately the sonic temperature, for the effects of wind blowing normal to the sonic measurement path.

The equations derived by Schotanus et al. (1983) apply to sonic anemometers that make speed of sound measurements from a single pair of transducers. Liu et al. (2001) extends these equations to sonic anemometers that measure the speed of sound on all three axes and then averages the results to a single speed of sound as with the CSAT3. Liu et al. (2001) assume that the geometry of each individual three-dimensional anemometer is ideal when they derive the factors given in their Table 1.

NOTE

Liu et al. (2001) recommends that CSAT3 sonic temperature variances and sonic sensible heat flux be corrected for the effects of cross wind. However, CSAT3 users need not make these corrections to their fluxes because the CSAT3 performs an online correction. Correcting CSAT3 data off-line for cross wind effects will cause errors in the measured fluxes.

8. CSAT3 Trigger

The CSAT3 takes a measurement of wind speed and the speed of sound when triggered from one of three different sources. The trigger sources are the internal CSAT3 timer, SDM communications, or RS-232 communications.

In the case of the CSAT3 internal timer, the Execution Parameter exactly defines the trigger rate. The Execution Parameter is set either via a SDM or RS-232 command. Once set, this value is stored in non-volatile memory and is used thereafter. If the CSAT3 is set to use its internal trigger, it will take measurements at this rate until it is changed.

Note that the power consumption of the anemometer is dependent on the Execution Parameter and the trigger rate (see Figure 4).

Where an external trigger source is used it is important to make sure the trigger rate is greater than or equal to the Execution Parameter. This is because, as discussed above, the Execution Parameter is used to define how much the wind speed could have changed from the previous reading. If the anemometer is triggered too slowly, under gusty conditions, it is possible that the CSAT3 sets its search window to a point in time which misses the ultrasonic pulse. This will give erroneous readings.

Conversely, if the trigger rate is slightly higher than the Execution Parameter, the CSAT3 will consume more power than necessary and at much higher rates the CSAT3 will simply not be able to take measurements at the speed required, because it is analyzing wider time windows than necessary and it will run out of time. The latter will cause the CSAT3 to output 61503 as the diagnostic word, indicating an overrun (see Section 10.4 and B.4).

If the SDM or PC fails to provide a trigger to the CSAT3, it will enter a lost trigger state after three seconds. The data acquisition system will then have to reissue the acquire signal command (see Section 10.3 and B.1).

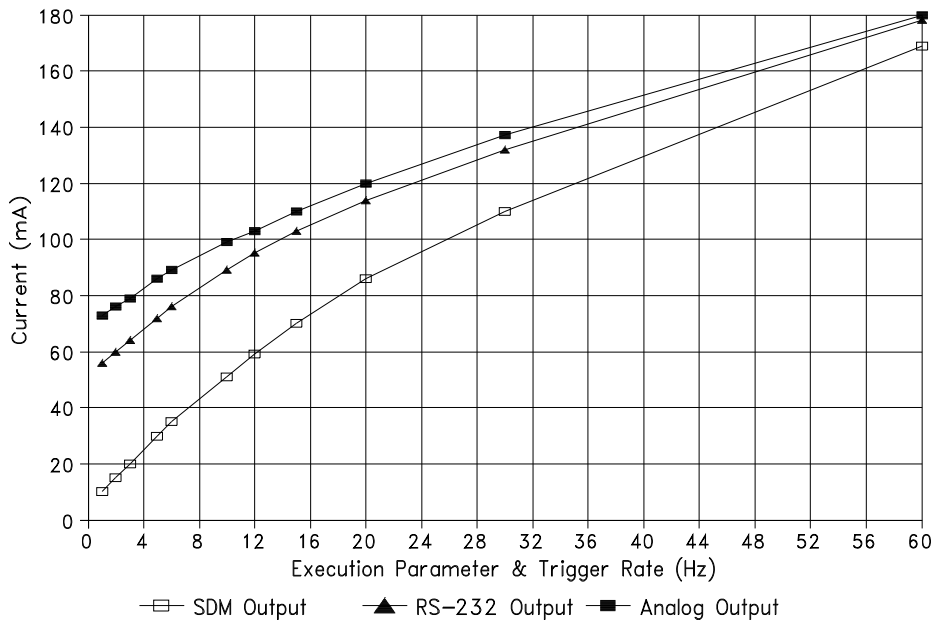

FIGURE 4. Typical Average CSAT3 Current Drain at +12 VDC

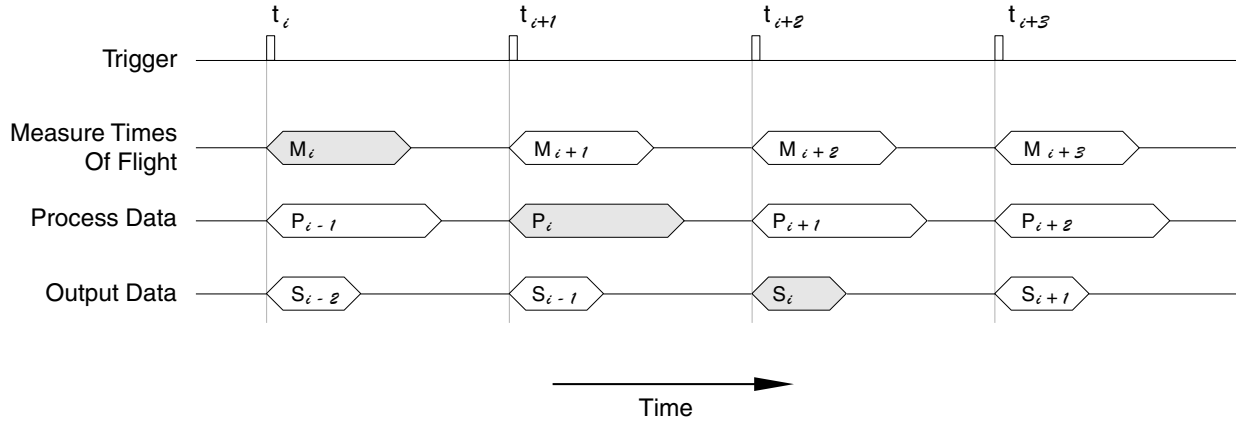

FIGURE 5. CSAT3 Pipeline Delay

8.1 Sampling Modes

The CSAT3 can be configured to make measurements in either a single-measurement mode or an oversampled mode. In the single-measurement mode, the CSAT3 makes one measurement synchronously with the trigger provided by the CSAT3 internal trigger, SDM communications, or RS-232 communications. In the oversampled mode, the CSAT3s internal trigger, SDM communications, or RS-232 communication trigger several measurements. The average of these measurements is output at the trigger rate.

8.1.1 Single-Measurement Mode

In the single-measurement mode, the anemometer makes one measurement per trigger. With this approach, the anemometer’s high frequency response is limited only by the geometry of the anemometer head, thus minimizing the possibility of under-estimating high-frequency signal variations and covariations. However, this approach also aliases high-frequency information to lower frequencies. This aliasing is apparent in spectra from an upwards tail, when compared to the $-5/3$ power relationship, at frequencies approaching the Nyquist frequency (one-half the sample rate). This aliasing does not compromise the variances and covariances (and therefore, fluxes) computed from aliased data. The variance and covariance calculations are not frequency dependent, they simply measure a signal’s total variation and two signal’s total covariation, respectively.

8.1.2 Oversample Mode

In the oversample mode, the CSAT3 makes wind measurements at 60 Hz and then block averages those measurements to 10 or 20 Hz output. The output is synchronized to any one of the three triggers. The oversampling modes minimize aliasing by limiting the anemometer’s high-frequency response. The 60 Hz data is filtered with a $\sin x/x$ function.

The oversampled modes maintain synchronization to the master trigger. In the six-times oversampled mode, the CSAT3 interpolates six minor triggers that are centered on the 10 Hz master trigger. In the three-times oversample mode, the CSAT3 interpolates three minor triggers that are centered on the 20 Hz

master trigger. For compatibility with the existing single-sampled modes, the block-averaged output data have a fixed delay of two periods of the master trigger.

9. Data Pipeline Delay

When the CSAT3 is triggered to take a measurement, it determines the times of flight for all three transducer pairs. This process takes between 12 to 18 mSec, depending on the Execution Parameter. After determining the times of flight, the CSAT3 corrects these times of flight for transducer delays, and then calculates the u_x , u_y , and u_z components of wind speed. In addition, it corrects each of the three sonic paths speed of sound for the effects of wind blowing perpendicular to the sonic path. The three corrected speed of sound values are then averaged.

All the CSAT3 output signals (SDM, RS-232, and analog) have the two measurement pipeline delay. The wind speeds and speed of sound that are sent to the data acquisition system were measured by the anemometer two triggers ago (see Figure 5). To optimize system performance, the CSAT3 uses parallel processing techniques. These techniques cause a two measurement delay between the trigger and data output. This delay applies at all trigger frequencies.

When the covariance is found between the turbulence data from the CSAT3 and other scalar sensors, the data from each sensor has to be aligned in time. This can be done online with a datalogger.

10. Datalogger Programming using SDM

The CRBasic CSAT3 () and EDLOG SDM-CSAT3 (P107) instructions are Input/Output instructions that control and retrieve data from the CSAT3. These instructions are available on the CR3000, CR1000, CR5000, CR800/850, CR9000(X), and CR23X, 21X (with CSAT3 PROMs), CR10X, and CR10 (with CSAT3 PROMs or library special PROMs).

10.1 CRBasic CSAT3 () Instruction

The CSAT3 () instruction is a five parameter CRBasic instruction to control and retrieve data from the CSAT3. The parameters for this instruction are given in Table 13 and described in Section 10.3.

TABLE 13. CSAT3 () Instruction Parameters
--

CSAT3 (Dest,Reps,SDMAddress,Command,Option)

10.2 EDLOG SDM-CSAT3 (P107) Instruction

The SDM-CSAT3 (P107) is a four parameter instruction. The parameters are given in Table 14 and described in Section 10.3.

PARAMETER NUMBER	DATA TYPE	DEFAULT DESCRIPTION
01:	2	Reps
02:	2	SDM Address
03:	2	Option
04:	4	Ux Input Location

10.3 Datalogger Instruction Parameters

Dest: The destination variable to store the first of five data values to a CRBasic datalogger. The variable must be declared as a float (default) with at least five elements. The CSAT3 returns the following data after receiving the “Trigger and Get Data” or “Get Data after a Group Trigger” command in the “Command” parameter: u_x , u_y , u_z , c or T_s , and a diagnostic word, where u_x , u_y , and u_z are the wind speeds along the x, y, and z axes defined by the anemometer head (see Figure 1), c is the speed of sound, and T_s is the sonic virtual temperature. The wind speed and the speed of sound are in units of $m\ s^{-1}$, and T_s is in degrees Celsius. If the Reps option is greater than 1, the number of elements required in the destination variable is Reps * 5.

Reps: The number of CSAT3s on the SDM bus that will be sequentially addressed with the CSAT3()/SDM-CSAT3 (P107) instruction.

SDMAddress/SDM Address: The unique SDM Address of the CSAT3 connected to the datalogger. In CRBasic dataloggers, the CSAT3 address is entered as a base ten number. In EDLOG dataloggers, the CSAT3 address is entered as a base four number (see Table 1). The SDM Address is sequentially incremented if the Reps option is greater than 1.

The wind data and the speed of sound (sonic virtual temperature) is scaled by the instruction into $m\ s^{-1}$ and degrees Celsius.

CAUTION

SDM address 15 (base 10)/33 (base 4) is a special address used during a Group Trigger. Do not program the datalogger to address SDM address 15/33.

Command/Option 90: “Trigger and Get Wind & c Data” sends a measurement trigger to the CSAT3 whose SDM address is specified in SDMAddress/SDM Address parameter. The CSAT3 also sends data to the datalogger.

Command/Option 91: “Trigger and Get Wind & T_s Data” sends a measurement trigger to the CSAT3 whose SDM address is specified in the SDMAddress/SDM Address parameter. The CSAT3 also sends wind speed and sonic virtual temperature (defined in Equation (9) in Appendix C) via the SDM bus to the datalogger.

Command/Option 92: “Trigger and Get Wind & c-340 Data” sends a measurement trigger to the CSAT3 whose SDM address is specified in SDMAddress/SDM Address parameter. The CSAT3 also sends wind speed and the speed of sound minus 340 m s⁻¹ via the SDM bus to the datalogger.

Command/Option 97: “Get Wind and c-340 Data After a Group Trigger”. The CSAT3, specified in SDMAddress/SDM Address parameter, sends wind speed and the speed of sound minus 340 m s⁻¹ to the datalogger. A new measurement is not triggered. The CSAT3 ()/SDM-CSAT3 (P107) Instruction must be preceded by the SDMTrigger/Group Trigger (P110) Instruction to use this option.

Command/Option 98: “Get Wind and T_s Data After a Group Trigger”. The CSAT3, specified in SDMAddress/SDM Address parameter, sends the wind speed and sonic virtual temperature (defined in Equation (9) in Appendix C) to the datalogger. A new measurement is not triggered. The CSAT3 ()/SDM-CSAT3 (P107) Instruction must be preceded by the SDMTrigger/Group Trigger (P110) Instruction to use this option.

Command/Option 99: “Get Wind and c Data After a Group Trigger”. The CSAT3, specified in SDMAddress/SDM Address parameter, sends the wind speed and speed of sound to the datalogger. A new measurement is not triggered. The CSAT3 ()/SDM-CSAT3 (P107) Instruction must be preceded by the SDMTrigger/Group Trigger (P110) Instruction.

CAUTION

Command/Option 90, 91, 98, or 99 must not be used to collect data from a CSAT3 running a cold shifted calibration, see Section 11.2.1.

Option 1, 2, 3, 5, 6, 10, 12, 15, 20, 30, and 60: “Set Execution Parameter” tells the CSAT3 which measurement parameters to use and what frequency to expect the measurement trigger from the datalogger. The datalogger Execution Interval and the appropriate CSAT3 Execution Parameter is summarized in Tables 15 and 16.

Option 61 and 62: “Set Execution Parameter” tells the CSAT3 to oversample (Section 8.1.2) the wind measurements at a rate of 60 Hz and expect a trigger at a rate of 10 Hz (option 61) or 20 Hz (option 62) from a CR3000, CR1000, CR5000, CR800/850, CR9000(X), CR23X or 21X datalogger.

Option 51 and 52: “Set Execution Parameter” tells the CSAT3 to oversample (Section 8.1.2) the wind measurements at a rate of 48 Hz and expect a trigger at a rate of 8 Hz (option 51) or 16 Hz (option 52) from a CR10(X) datalogger.

TABLE 15. CR3000, CR1000, CR5000, CR800/850, CR9000(X), CR23X and 21X Execution Interval and CSAT3 Execution Parameter

Datalogger Execution Interval (seconds)	Datalogger Execution Frequency (Hz)	CSAT3 Execution Parameter
0.05	20	20
0.0625	16	15
0.075	13.333	12
0.0875 to 0.1	11.429 to 10	10
0.1125 to 0.1625	8.889 to 6.154	6
0.175 to 0.2	5.714 to 5	5
0.2125 to 0.325	4.706 to 3.077	3
0.3375 to 0.5	2.963 to 2	2
0.5125 to 1	1.951 to 1	1

TABLE 16. CR10(X) Execution Interval and CSAT3 Execution Parameter

Datalogger Execution Interval (seconds)	Datalogger Execution Frequency (Hz)	CSAT3 Execution Parameter
0.0625	16	15
0.078125	12.8	12
0.09375	10.667	10
0.109375 to 0.15625	9.143 to 6.4	6
0.171875 to 0.1875	5.818 to 5.333	5
0.203125 to 0.328125	4.923 to 3.047	3
0.34375 to 0.5	2.909 to 2	2
0.515625 to 1	1.939 to 1	1

Ux Input Location: The Input Location to store the first of five data values to an EDLOG datalogger. The CSAT3 returns the following data after receiving the “Trigger and Get Data” or “Get Data after a Group Trigger” command in the option parameter: u_x , u_y , u_z , c or T_s , and a diagnostic word, where u_x , u_y , and u_z are the wind speeds along the x, y, and z axes defined by the anemometer head (see Figure 1), c is the speed of sound, and T_s is the sonic virtual temperature. The wind speed and the speed of sound are in units of $m\ s^{-1}$, and T_s is in degrees Celsius. If the Repts option in parameter 1 is greater than 1, the number of sequential Input Locations used is $Reps * 5$.

10.4 Diagnostic Word

The fifth output from the CSAT3 is the diagnostic word. The diagnostic word describes the status of the anemometer and is useful in filtering data. For example, when the anemometer is locking in on the ultrasonic signals after receiving the acquire signals command, the NaN or -99999’s it sends to the datalogger for the science data can be filtered out of the statistics based on the diagnostic word, see the example program in Section 10.6 and 10.7.

The CSAT3 (/SDM-CSAT3 instruction (P107), decodes the diagnostic word and represents it in base 10. The bits in the diagnostic word are grouped together into three categories. Bits 15 through 12 are four diagnostic flags (see Tables 17 and 18), bits 11 through 6 represent the range the measurements are

reported in (used by the datalogger), and bits 5 through 0 are a counter. A detailed description of decoding the diagnostic word is given in Appendix B.

TABLE 17. Diagnostic Word				
Diagnostic Word				
b15 - b12	b11 b10	b09 b08	b07 b06	b05 - b00
diagnostic flags	u _x range	u _y range	u _z range	counter

The following are four specific Diagnostic Words (Base 10) and the situation that produces them:

NaN or -99999, Anemometer does not Respond. This is the special case when the datalogger attempts to address an anemometer and the anemometer does not answer. This occurs if the anemometer is not connected to the SDM bus, the anemometer is not connected to a 12 Vdc power supply, or none of the anemometers on the SDM bus are set to the SDM address in the CSAT3 (/SDM-CSAT3 (P107) instruction.

61440, Lost Trigger. The anemometer has lost the trigger source, in this case all the diagnostic bits are set high, the range bits are set low, and the counter bits are low. This occurs if the anemometer is disconnected from the SDM bus; e.g. a loose SDM clock line. To bring the anemometer back on-line, connect the CSAT3 to the SDM bus and execute the CSAT3 (/SDM-CSAT3 (P107) instruction with the “Set Execution Parameter” Command/Option.

61503, No Data Available. The anemometer has no new data. In this case all the diagnostic bits are set high, the range bits are low, and all the counter bits are high. This occurs immediately after the anemometer receives the acquire signal command from the datalogger, e.g. a CSAT3 (/SDM-CSAT3 (P107) instruction with the “Set Execution Parameter” Command/Option. The no new data condition also occurs when the datalogger’s execution frequency (inverse of the execution interval) is much greater than the execution parameter the anemometer was told to use.

61441, SDM Communications Error. The datalogger and CSAT3 are unable to communicate correctly. Extending the SDM cable beyond the standard 7.62 m (25 ft.) and not slowing down the SDM clock with the SDMSpeed () instruction (CRBasic), or Instruction 115 (CR23X or CR10(X)) or 108 (21X) is the most common cause of this error. See Appendix D for details on identifying the appropriate SDM clock rate for a given cable length.

61442, Wrong CSAT3 embedded code. The CSAT3 is running a version of embedded code prior to version 3. Starting with embedded code version 3 and the CR5000, the configuration of the CSAT3 is done within the instruction, rather than in separate datalogger code. CSAT3s running a version of embedded code prior to 3 and deployed in systems using a CR3000, CR1000, CR5000, CR800/850, or CR9000X datalogger must upgrade to a version of CSAT3 embedded code that is 3 or greater.

TABLE 18. CSAT3 Diagnostic Flags

Bit Set High	Description	Comment
b15	Difference in the speed of sound between the three non-orthogonal axes is greater than 2.360 m s^{-1} (~ 4°C @ 25°C)	The anemometer path length may have been altered or the anemometer head is broken.
b14	Poor signal lock	There may be an obstruction in the anemometer path or on the transducer face.
b13	Sonic signal amplitude too high	An obstruction, in the anemometer path or on the transducer face, was removed.
b12	Sonic signal amplitude too low	There may be an obstruction in the anemometer path or on the transducer face.

10.5 SDMTrigger (/)SDM-Group Trigger (P110)

A SDM Input/Output instruction that controls SDM devices that support the group trigger protocol, including the CSAT3. Up to 15 group trigger devices can be connected to the SDM bus. All group trigger devices are triggered to make simultaneous measurements with the SDMTrigger/SDM Group Trigger (P110). The data from each device is then retrieved with the appropriate device specific instruction. For the CSAT3, the CSAT3 (/)SDM-CSAT3 (P107) Instruction with the “Get data after Group Trigger” Command/Option (97, 98, or 99) is used to retrieve the data.

10.6 Example CRBasic Datalogger Program

In the following example, a CR3000 is used to collect data from the CSAT3 using SDM communications. The CR3000 will trigger each wind measurement over the SDM bus and retrieve the data.

TABLE 19. Wiring for Program Example 1

Description	Color	CR3000
SDM Data	Green	SDM-C1
SDM Clock	White	SDM-C2
SDM Enable	Brown	SDM-C3
Digital Ground	Black	G
SDM Signal Shield	Clear	G
Power	Red	+12 Vdc
Power Referenece	Black	G
Power Shield	Clear	G

```

Const CSAT_OPT = INT (1000/SCAN_INTERVAL)      'Compute CSAT3 Execution Parameter.
Const SDM_PER = 30                             'Default SDM clock speed.

*** Variables ***

'Online lagged CSAT3 data.
Public wind(5)
Alias wind(1) = Ux
Alias wind(2) = Uy
Alias wind(3) = Uz
Alias wind(4) = Ts
Alias wind(5) = diag_csat
Units Ux = m/s
Units Uy = m/s
Units Uz = m/s
Units Ts = C
Units diag_csat = unitless

Public diag_bits(4) AS Boolean
Alias diag_bits(1) = del_T_f
Alias diag_bits(2) = sig_lck_f
Alias diag_bits(3) = amp_h_f
Alias diag_bits(4) = amp_l_f
Units diag_bits = samples

Public batt_volt                               'CRBasic datalogger battery voltage.
Public panel_temp
Units batt_volt = V
Units panel_temp = C

'Wind directions and speed.
Dim wnd_out(8)
'Alias wnd_out(1) = wnd_spd - in compass coordinate system, same as CSAT3.
'Alias wnd_out(2) = rslt_wnd_spd - in compass coordinate system, same as CSAT3.
Alias wnd_out(3) = wnd_dir_compass
'Alias wnd_out(4) = std_wnd_dir - in compass coordinate system, same as CSAT3.
Alias wnd_out(5) = wnd_spd
Alias wnd_out(6) = rslt_wnd_spd
Alias wnd_out(7) = wnd_dir_csat3
Alias wnd_out(8) = std_wnd_dir
Units wnd_dir_compass = degrees
Units wnd_spd = m/s
Units rslt_wnd_spd = m/s
Units wnd_dir_csat3 = degrees
Units std_wnd_dir = degrees

'Diagnostic variables.
Dim disable_flag_on(2) AS Boolean             'Intermediate processing disable flags.
Dim n                                         'Number of samples in the online stats.
Units n = samples

'Working variables.
Dim wind_east                               'East wind in compass coordinate system.
Dim wind_north                              'North wind in compass coordinate system.
Dim diag_csat_work AS Long

*** Final Output Data Tables ***

```

```

'Online stats data.
DataTable (stats,TRUE,-1)
  DataInterval (0,OUTPUT_INTERVAL,Min,10)

  Average (1,Ts,IEEE4,disable_flag_on(1))
  StdDev (1,Ts,IEEE4,disable_flag_on(1))
  Average (1,Ux,IEEE4,disable_flag_on(1))
  StdDev (1,Ux,IEEE4,disable_flag_on(1))
  Average (1,Uy,IEEE4,disable_flag_on(1))
  StdDev (1,Uy,IEEE4,disable_flag_on(1))
  Average (1,Uz,IEEE4,disable_flag_on(1))
  StdDev (1,Uz,IEEE4,disable_flag_on(1))

  Sample (1,wnd_dir_compass,IEEE4)
  Sample (1,wnd_dir_csat3,IEEE4)
  Sample (1,wnd_spd,IEEE4)
  Sample (1,rslt_wnd_spd,IEEE4)
  Sample (1,std_wnd_dir,IEEE4)

  Totalize (1,n,IEEE4,disable_flag_on(1))

  Totalize (1,n,IEEE4,NOT (disable_flag_on(1) OR disable_flag_on(2)))
  FieldNames ("csat_warnings")

  Totalize (1,n,IEEE4,NOT (del_T_f) OR NOT (disable_flag_on(2)))
  FieldNames ("del_T_f_Tot")
  Totalize (1,n,IEEE4,NOT (sig_lck_f) OR NOT (disable_flag_on(2)))
  FieldNames ("sig_lck_f_Tot")
  Totalize (1,n,IEEE4,NOT (amp_h_f) OR NOT (disable_flag_on(2)))
  FieldNames ("amp_h_f_Tot")
  Totalize (1,n,IEEE4,NOT (amp_l_f) OR NOT (disable_flag_on(2)))
  FieldNames ("amp_l_f_Tot")

  Average (1,panel_temp,IEEE4,FALSE)
  Average (1,batt_volt,IEEE4,FALSE)
EndTable

'*** Working Data Tables ***

'Compute the wind direction This data is output every OUTPUT_INTERVAL minutes.
DataTable (wnd_vec,TRUE,1)
  DataInterval (0,OUTPUT_INTERVAL,Min,1)

  'Compute wind direction from CSAT3 data.
  WindVector (1,wind_east,wind_north,IEEE4,disable_flag_on(1),0,1,2)
  WindVector (1,Uy,Ux,IEEE4,disable_flag_on(1),0,1,2)
EndTable

'*** Program ***

```

```

BeginProg
  n = 1

  'Set all CSAT3 variables to NaN.
  Move (Ux,5,NaN,1)

  'Set the SDM clock speed.
  SDMSpeed (SDM_PER)

  Scan (SCAN_INTERVAL,mSec,3,0)
  'CRBasic datalogger panel temperature.
  PanelTemp (panel_temp,250)

  'Get CSAT3 wind and sonic temperature data.
  CSAT3 (Ux,1,3,91,CSAT_OPT)

  'Measure battery voltage.
  Battery (batt_volt)

  'Copy and convert CSAT3 for compass wind vector computation.
  wind_east = -1*Uy
  wind_north = Ux

  'Define 61502 as NaN.
  If ( diag_csat = NaN ) Then ( diag_csat = 61502 )

  'Break up the four CSAT3 warning flags into four separate bits.
  diag_csat_work = diag_csat
  del_T_f = diag_csat_work AND &h8000
  sig_lck_f = diag_csat_work AND &h4000
  amp_h_f = diag_csat_work AND &h2000
  amp_l_f = diag_csat_work AND &h1000

  'Turn on the intermediate processing disable flag when any CSAT3 warning flag is
  'high, including the special cases NaN (61502), a Lost Trigger (61440), No Data
  '(61503), an SDM error (61441), or wrong CSAT3 embedded code (61442).
  disable_flag_on(1) = diag_csat_work AND &hf000

  'Turn on only when CSAT3 diagnostic warning flags are set.
  disable_flag_on(2) = ( disable_flag_on(1) AND NOT (Ts = NaN) )

  'Save the four most significant bits of the CSAT3 diagnostics, except for the
  'special cases NaN (61502), a Lost Trigger (61440), No Data (61503), an SDM
  'error (61441), or wrong CSAT3 embedded code (61442).
  If ( diag_csat_work < &hf000 ) Then ( diag_csat = INT (diag_csat_work/&h1000) )

  'Compute the online wind vector statistics.
  CallTable wnd_vec

  If ( wnd_vec.Output(1,1) ) Then
    GetRecord (wnd_out(1),wnd_vec,1)

  'Compass wind direction will be between 0 and 360 degrees.

```

```

        wnd_dir_compass = (wnd_dir_compass+CSAT3_AZIMUTH) MOD 360

        'CSAT3 wind direction will be between 0 to 180 degrees and 0 to -180 degrees.
        If ( wnd_dir_csat3 ) > 180 Then ( wnd_dir_csat3 = wnd_dir_csat3-360 )
    EndIf
    CallTable stats
NextScan
EndProg
    
```

10.7 Example EDLOG Datalogger Program

In the following example, a CR23X is used to collect data from the CSAT3 using SDM communications. The CR23X will trigger each wind measurement over the SDM bus and retrieve the data.

TABLE 20. Wiring for Program Example 2

Description	Color	CR3000
SDM Data	Green	SDM-C1
SDM Clock	White	SDM-C2
SDM Enable	Brown	SDM-C3
Digital Ground	Black	G
SDM Signal Shield	Clear	G
Power	Red	+12 Vdc
Power Referenece	Black	G
Power Shield	Clear	G

EXAMPLE 2. Measuring the CSAT3 Using the SDM Output and a CR23X Datalogger

```

;{CR23X}
;
;22 April 2001

;Copyright (c) 2001 Campbell Scientific, Inc. All rights reserved.

;Flags

;Flag 1 - Set low (default) to configure the CSAT3.
;Set high after CSAT3 is configured.

;() -> Compass coordinate system
;{} -> Right handed coordinate system
;
;
;
;           theta      (N)
;           \         {-x}
;           \         |
    
```



```

;Copy the CSAT3 Ux and Uy instantaneous wind to compute CSAT3 wind direction.
;
5: Z=X (P31)
  1: 1      X Loc [ Ux   ]
  2: 10     Z Loc [ Ux_copy ]

6: Z=X (P31)
  1: 2      X Loc [ Uy   ]
  2: 12     Z Loc [ Uy_copy ]

7: Z=ABS(X) (P43)
  1: 5      X Loc [ diag  ]
  2: 36     Z Loc [ diag_abs ]

;Disable Intermediate Processing if any of the diagnostic flags are
;on,vi.e. diag >= 4096 or any of the science data is "Not a
;Number", (-99999).
;
8: If (X<=>F) (P89)
  1: 36     X Loc [ diag_abs ]
  2: 3      >=
  3: 4096   F
  4: 19     Set Intermed. Proc. Disable Flag High (Flag 9)

;Decode CSAT3 diagnostic flags.
;
9: Do (P86)
  1: 2      Call Subroutine 2

;Process CSAT3 output data every minute.
;
10: If time is (P92)
  1: 0      Minutes (Seconds --) into a
  2: 1      Interval (same units as above)
  3: 10     Set Output Flag High (Flag 0)

11: Set Active Storage Area (P80)
  1: 3      Input Storage Area
  2: 13     Loc [ wnd_spd_a ]

;Compute the horizontal wind speed and wind direction in the
;compass coordinate system and in the CSAT3 right handed orthogonal
;coordinate system.
;
12: Wind Vector (P69)
  1: 2      Reps
  2: 0      Samples per Sub-Interval
  3: 10     S,  $\theta_1$ , &  $\sigma(\theta_1)$  Orth.
  4: 9      Wind Speed/East Loc [ Prop_E ]
  5: 11     Wind Direction/North Loc [ Prop_N ]

```

13: Do (P86)
 1: 29 Set Intermed. Proc. Disable Flag Low (Flag 9)

;Process CSAT3 wind direction data.

;

14: If Flag/Port (P91)
 1: 10 Do if Output Flag is High (Flag 0)
 2: 3 Call Subroutine 3

;Output CSAT3 data.

;

15: If Flag/Port (P91)
 1: 10 Do if Output Flag is High (Flag 0)
 2: 10 Set Output Flag High (Flag 0)

16: Set Active Storage Area (P80)
 1: 1 Final Storage Area 1
 2: 100 Array ID

17: Real Time (P77)
 1: 110 Day,Hour/Minute (midnight = 0000)

18: Resolution (P78)
 1: 1 High Resolution

19: Sample (P70)
 1: 3 Reps
 2: 13 Loc [wnd_spd_a]

20: Sample (P70)
 1: 1 Reps
 2: 17 Loc [csat_dir]

21: Average (P71)
 1: 4 Reps
 2: 1 Loc [Ux]

22: Standard Deviation (P82)
 1: 4 Reps
 2: 1 Sample Loc [Ux]

23: Totalize (P72)
 1: 7 Reps
 2: 20 Loc [smpls]

*Table 2 Program
 02: 0 Execution Interval (seconds)

*Table 3 Subroutines

```

;Configure CSAT3.
;
1: Beginning of Subroutine (P85)
  1: 1          Subroutine 1

;Check the diagnostic word for lost trigger condition.
;Set Flag 1 low to reconfigure the CSAT3 if it is in a
;lost trigger state.
;
2: If (X<=>F) (P89)
  1: 5          X Loc [ diag  ]
  2: 1          =
  3: 61440     F
  4: 21        Set Flag 1 Low

;Configure the CSAT3. This is done the first time
;through Table 1 or if the CSAT3 loses the trigger.
;
3: If Flag/Port (P91)
  1: 21        Do if Flag 1 is Low
  2: 30        Then Do

;Load the angle between North and the CSAT3 head.
;The station operator must enter the angle theta.
;
4: Z=F (P30)
  1: 0          F ;<- unique value
  2: 0          Exponent of 10
  3: 35        Z Loc [ theta  ]

;Load the constants used in recording the number of times the
;diagnostic flags were on.
;
5: Z=F (P30)
  1: 32768     F
  2: 0          Exponent of 10
  3: 31        Z Loc [ _8000h ]

6: Z=F (P30)
  1: 16384     F
  2: 0          Exponent of 10
  3: 32        Z Loc [ _4000h ]

7: Z=F (P30)
  1: 8192      F
  2: 0          Exponent of 10
  3: 33        Z Loc [ _2000h ]

8: Z=F (P30)
  1: 4096      F
  2: 0          Exponent of 10
  3: 34        Z Loc [ _1000h ]

```

```

;Look for a diag that is not -99999, meaning that the
;CSAT3 is connected to the CR23X and the two devices
;are communicating correctly.
;
9: If (X<=>F) (P89)
  1: 5      X Loc [ diag  ]
  2: 3      >=
  3: 0      F
  4: 30     Then Do

;Send the configuration command to the CSAT3 only if
;it is not acquiring the signal or making measurements,
;e.g. diag <> 61503.
;
10: If (X<=>F) (P89)
  1: 5      X Loc [ diag  ]
  2: 2      <>
  3: 61503  F
  4: 30     Then Do

11: Do (P86)
  1: 11     Set Flag 1 High

;Configure CSAT3 with 10 Hz parameters.
;
12: SDM-CSAT3 (P107)
  1: 1      Reps
  2: 3      SDM Address
  3: 10     Set Execution Parameter
  4: 1      Ux Input Location [ Ux  ]

13: End (P95)

14: End (P95)

15: End (P95)

16: End (P95)

;Each diagnostic flag, that is encoded in the diagnostic word
;(diag), is assigned an Input Location. These Input Locations
;serve as flags and take on values of one or zero.
;
17: Beginning of Subroutine (P85)
  1: 2      Subroutine 2

```

```

;Set the flags low (set each "flag's" input location = 0) before
;recording the number of samples, Not a Number (NaN), or diagnostic
;flags that were on.
;

```

```

18: Block Move (P54)

```

```

1: 7          No. of Values
2: 19         First Source Loc [ zero  ]
3: 1          Source Step
4: 20         First Destination Loc [ smpls ]
5: 1          Destination Step

```

```

19: If Flag/Port (P91)

```

```

1: 19         Do if Flag 9 is High
2: 30         Then Do

```

```

;Set "NaN" flag.
;

```

```

20: Z=F (P30)

```

```

1: 1          F
2: 0          Exponent of 10
3: 21         Z Loc [ NaN_csat ]

```

```

21: Else (P94)

```

```

;Set "sample used" flag.
;

```

```

22: Z=F (P30)

```

```

1: 1          F
2: 0          Exponent of 10
3: 20         Z Loc [ smpls  ]

```

```

23: End (P95)

```

```

24: Z=X (P31)

```

```

1: 5          X Loc [ diag  ]
2: 30         Z Loc [ diag_work ]

```

```

25: If (X<=>F) (P89)

```

```

1: 30         X Loc [ diag_work ]
2: 2          <>
3: 61440     F
4: 30         Then Do

```

```

26: If (X<=>F) (P89)

```

```

1: 30         X Loc [ diag_work ]
2: 1          =
3: 61503     F
4: 30         Then Do

```

```

;Set the F03F (no data available) flag.
;
27: Z=F (P30)
   1: 1      F
   2: 0      Exponent of 10
   3: 26     Z Loc [ F03F_f ]

28: Else (P94)

;Set the delta temp (del_T_f), tracking (track_f), amplitude high
;amp_h_f), or amplitude low (amp_l_f) flag high if the CSAT3 is
;reporting those flags as set.
;
29: Beginning of Loop (P87)
   1: 0      Delay
   2: 4      Loop Count

30: If (X<=>Y) (P88)
   1: 30     X Loc [ diag_work ]
   2: 3      >=
   3: 31 --  Y Loc [ _8000h ]
   4: 30     Then Do

31: Z=F (P30)
   1: 1      F
   2: 0      Exponent of 10
   3: 22 --  Z Loc [ del_T_f ]

32: Z=X-Y (P35)
   1: 30     X Loc [ diag_work ]
   2: 31 --  Y Loc [ _8000h ]
   3: 30     Z Loc [ diag_work ]

33: End (P95)

34: End (P95)

35: End (P95)

36: End (P95)

37: End (P95)

;Process CSAT3 Output data.
;
38: Beginning of Subroutine (P85)
   1: 3      Subroutine 3

```

```

;Add the offset (theta) between the CSAT3 negative x-axis and
;North.
;
39: Z=X+Y (P33)
   1: 14      X Loc [ cmpss_dir ]
   2: 35      Y Loc [ theta  ]
   3: 14      Z Loc [ cmpss_dir ]

;Ensure that the compass wind direction is positive.
;
40: If (X<=>F) (P89)
   1: 14      X Loc [ cmpss_dir ]
   2: 4       <
   3: 0       F
   4: 30      Then Do

41: Z=X+F (P34)
   1: 14      X Loc [ cmpss_dir ]
   2: 360     F
   3: 14      Z Loc [ cmpss_dir ]

42: End (P95)

;Ensure that the compass wind direction (cmpss_dir) falls between
;0 and 360 degrees.
;
43: Z=X MOD F (P46)
   1: 14      X Loc [ cmpss_dir ]
   2: 360     F
   3: 14      Z Loc [ cmpss_dir ]

;Ensure that the csat3 wind direction (csat_dir) falls between
;between 180 and -180 degrees.
;
44: If (X<=>F) (P89)
   1: 17      X Loc [ csat_dir ]
   2: 3       >=
   3: 180     F
   4: 30      Then Do

45: Z=X+F (P34)
   1: 17      X Loc [ csat_dir ]
   2: -360    F
   3: 17      Z Loc [ csat_dir ]

46: End (P95)

47: End (P95)

End Program

```

```

-Input Locations-
1 Ux
2 Uy
3 Uz
4 Ts
5 diag
6 _____
7 _____
8 _____
9 Prop_E
10 Ux_copy
11 Prop_N
12 Uy_copy
13 wnd_spd_a
14 cmpss_dir
15 dir_std_a
16 wnd_spd_b
17 csat_dir
18 dir_std_b
19 zero
20 smpls
21 NaN_csat
22 del_T_f
23 track_f
24 amp_h_f
25 amp_l_f
26 F03F_f
27 _____
28 _____
29 _____
30 diag_work
31 _8000h
32 _4000h
33 _2000h
34 _1000h
35 theta
36 diag_abs

```

11. Maintenance

The CSAT3, like other ultrasonic anemometers, is unable to measure wind when water droplets completely obscure the face of the transducers. The wicks help remove some of the water, however, under some conditions may not be adequate. The CSAT3 will be ready to measure wind as soon as the water droplets either evaporate or are removed by the station operator. Remove the water droplets by dabbing a cotton swab or tissue on the face of the transducer.

CAUTION

Lightly dab the face of the transducers to remove water droplets. Applying excessive force on the face of the transducer may separate the matching layer from the brass housing.

There are no user serviceable components on the CSAT3. The only time the electronics box must be opened is to change the SDM address.

11.1 Wicks

CSAT3 embedded code version 4 and the wicks work together to improve the performance of the CSAT3 in rainy conditions. It is up to the station operator to decide whether the wicks are necessary or not. If they are not, gently remove the wicks from the transducers, taking care not to damage or peel the matching layer (rubber tips) from the brass housing of the transducers. Remove the wicks during the winter. The wicks will accumulate snow or freezing rain to the point where the transducer face will be obscured.

If the wicks are to be permanently installed at the site, ensure that the wicks are located in the proper position. The top wick must be flush with the transducer face, with the wick tail located at the lowest point of the transducer (Figure 6 left). The end of the bottom transducer wick must extend above the transducer face by between one half and one mesh lines (Figure 6 right). Secure the wicks to the transducer with a drop of adhesive, e.g. super glue.

Replacement top wicks (p/n 17388) and bottom wicks (p/n 17389) can be purchased from Campbell Scientific. A complete set of wicks consists of three top wicks and three bottom wicks.

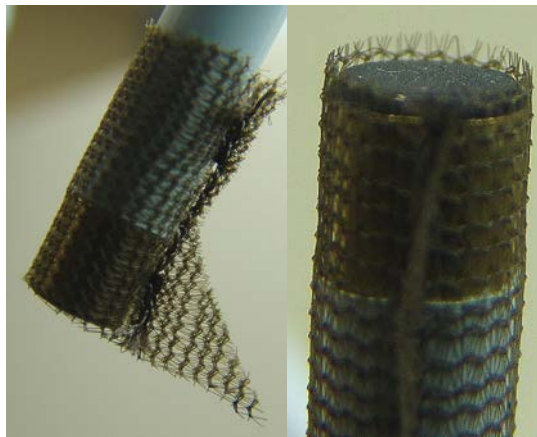

FIGURE 6. Proper Location of the Top (p/n 17388) and Bottom (p/n 17389) Wicks

WARNING

Placing wicks on a CSAT3 running embedded code version 3 will not improve the CSAT3s performance in the rain. The wicks prevent large drops of water that completely obscure the sonic signals from accumulating on the transducer faces and are part one of a two part solution in operating in rainy conditions. The second part is in the digital signal processing in embedded code version 4.

11.2 Calibration

The CSAT3 is calibrated over the temperature range of -30° to $+50^{\circ}\text{C}$ (standard) or -40° to $+40^{\circ}\text{C}$ (cold shifted). The CSAT3 may or may not make measurements outside the calibration range. Any measurements taken outside the calibration range will be suspect. The CSAT3 does not require any field calibration.

WARNING

The CSAT3 electronics box contains unique calibration information for its respective sensor head. Do not mismatch CSAT3 sensor heads and electronics. Doing so will result in erroneous wind and speed of sound measurements.

If the CSAT3 requires a calibration, it will develop a wind offset greater than the specifications, or it will set diagnostic flags, under dry conditions with little to no wind and with no obstruction in the ultra sonic paths. CSAT3s running embedded code version 4 will develop the offset first and then possibly set diagnostic flags under dry conditions. CSAT3s running embedded code version 3 will set diagnostic flags before a wind offset develops.

11.2.1 Cold Shifted Calibration

A CSAT3 with a cold shifted calibration is calibrated over the temperature of -40° to $+40^{\circ}\text{C}$. To improve the speed of sound reporting resolution, the CSAT3 sends the speed of sound minus an offset to a datalogger via the SDM interface or a PC via the RS-232 interface. The data acquisition system must add the appropriate offset to determine the speed of sound. For the standard temperature range the offset 340 m s^{-1} . This offset is added by the CSAT3()/SDM-CSAT3 (P107) instruction Command/Option 90, 91, 98, and 99. For the cold shifted calibration range, the offset is 337 m s^{-1} .

The standard datalogger instruction reports either the speed of sound (c), option 90 or 99, or the sonic temperature (T_s), Command/Option 91 or 98, can not be used with a CSAT3 running a cold shifted calibration. Instead, use option 92 “Trigger and Get Wind & c-340 Data” or option 97 “Get Wind and c-340 Data After a Group Trigger” and then add 337 m s^{-1} . To find T_s , use Equation 9 in Appendix C.

11.2.2 Test for Wind Offset

To test wind offset on a CSAT3, create an environment where there is no wind. It is difficult to do this in the field, thus it is best to collect CSAT3 wind offset data in a field office or the lab. A zero wind environment can be created with a kitchen waste bin liner.

Mount the head using the horizontal mount boom or hang the head from the block that supports the CSAT3 upper and lower arms. Do not lay the CSAT3 head on its side or balance it on the transducers.

Cover the CSAT3 head with a medium (13 gallon) kitchen waste bin liner. Fold, tape, or tie closed the opening of the liner to prevent air from moving in and out of the liner. Ensure that the liner does not obstruct any of the three CSAT3 sonic paths.

Connect the CSAT3 power cable to a 12 Vdc power supply. Connect the CSAT3's RS-232 port to the PC's RS-232 port using the RS-232 cable that shipped with the CSAT3. This cable was originally located underneath the circular "cut out" in the CSAT3 case.

Start the CSAT3 PC support software (CSAT32.EXE) to establish communications between the PC and the CSAT3. A copy of the software is available from the Campbell Scientific web site, in the Support/Downloads section. If successful communications are established, the "Status" window will report "Good Data". To prevent erroneous measurements due to ultrasonic reflection within the plastic bag, select a 1 Hz Measurement Rate (Figure 7).

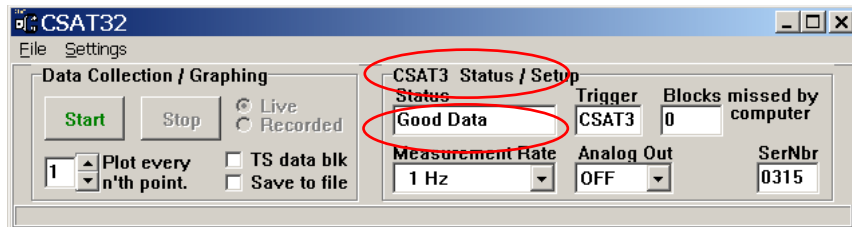

FIGURE 7. CSAT3 running at 1 Hz and successfully communicating with the CSAT3

Double click on the vertical axis and set it up as shown in Figure 8. Next, double click on the vertical axis label and set it up to report 2 significant digits (Figure 9).

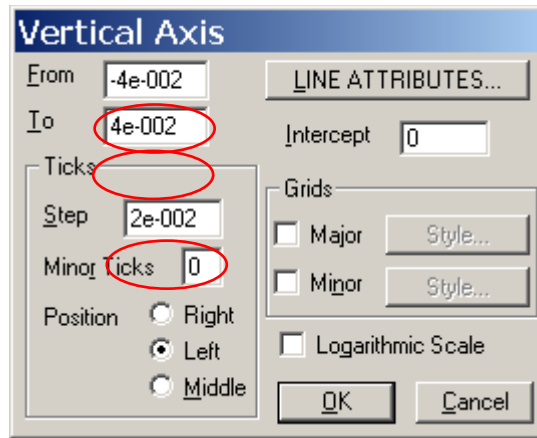

FIGURE 8. Recommended Settings for the Wind Vertical Axis

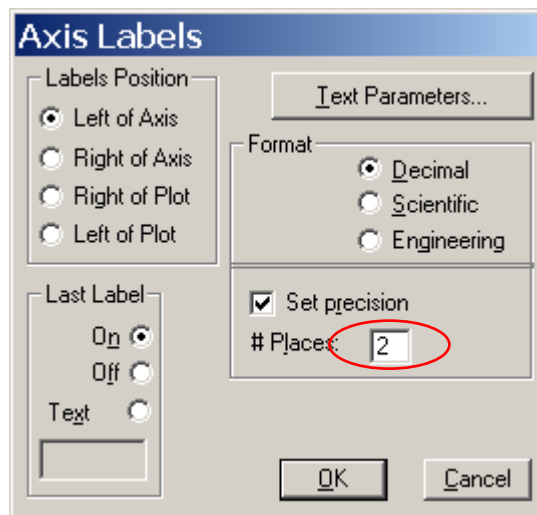

FIGURE 9. Recommended Settings for the Wind Vertical Axis Labels

Collect and graph 1 minute of wind data from the CSAT3 while it is in the zero wind environment (Figure 10). The wind offset should be less than $\pm 4 \text{ cm s}^{-1}$ (0.04 m s^{-1}) for u_x and u_y , and less than $\pm 2 \text{ cm s}^{-1}$ (0.02 m s^{-1}) for u_z . If the CSAT3 wind offset is greater than these specifications, contact Campbell Scientific, Inc. for an RMA number to recalibrate the CSAT3.

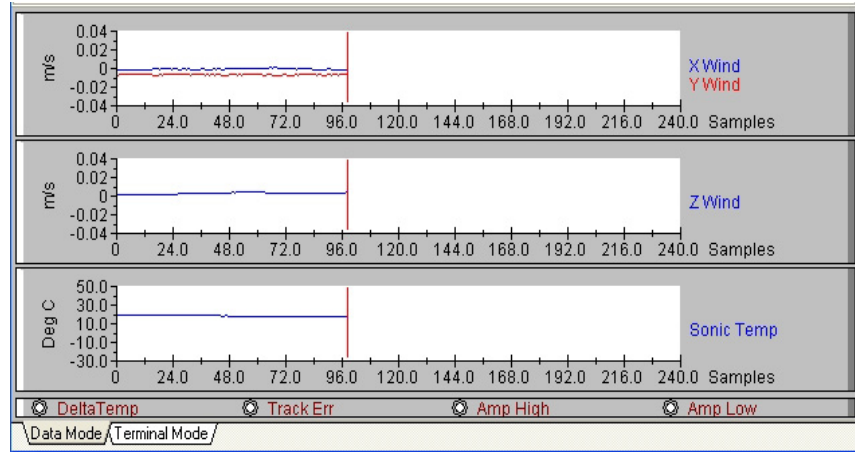

FIGURE 10. Wind Data from CSAT3 s/n 315; Wind Offsets within Specifications at 19°C.

12. Select Backdoor Commands

The CSAT3 supports a variety of Backdoor Commands used to configure the CSAT3 for use with a RS-232 data collection system.

Connect the CSAT3 to a PC using the RS-232 serial cable that was shipped with the CSAT3. Connect a 12 Vdc power supply to the CSAT3 using the SDM/Power cable. Start the CSAT3 PC support software (CSAT32.EXE). If the CSAT3 and PC are communicating successfully, the “Status” window will report the message “Good Data”. To gain access to the Long Status Message, place the CSAT3 into the terminal mode by clicking on the “Terminal Mode” tab in the support software. The CSAT3 will respond with the “>” prompt. If you are using some other telecommunications software, you will have to issue the “T” command to enter the terminal mode and the “D” command to return to the normal operating mode (data mode).

NOTE

Back door commands will not be accepted by the CSAT3 if it is communicating with a Campbell Scientific datalogger via SDM. The SDM communications must first be terminated by shutting down the program, turning off the datalogger, or disconnecting the brown SDM enable line from the datalogger.

If the CSAT3 successfully accepts and processes a command, it will respond with the “>” prompt. If an invalid command is issued to the CSAT3, it will respond with a “?” prompt. All commands issued to the CSAT3 must be followed by the <enter> key.

“??” – Long Status Message; the “??” command prompts the CSAT3 to return the Long Status Message. This message contains the current configuration of the CSAT3. Much of this information is used by Campbell Scientific staff during the calibration process; however, the following highlighted information may be of use to some CSAT3 users.

After receiving the “?” command, the CSAT3 will respond with text similar to that below for CSAT3s running embedded code version 3 or less,

```
ET= 10 ts=i XD=d GN=111a TK=1 UP=5 FK=0 RN=1 IT=1 DR=102 rx=2 fx=038 BX=0
AH=1 AT=0 RS=0 BR=0 RI=0 GO=00000 HA=0 6X=3 3X=2 PD=2 SD=0 ?d sa=1 WM=o
ar=0 ZZ=0 DC=6 ELo=021 021 021 ELb=021 021 021 TNo=dbb d TNb=ccc JD= 007
C0o=-2-2-2 C0b=-2-2-2 RC=0 tlo=9 9 9 tlb=9 9 9 DTR=01740 CA=0 TD= duty=026
AQ= 10 AC=1 CD=0 SR=1 UX=0 MX=0 DTU=02320 DTC=01160 RD=o ss=1 XP=2 RF=018
DS=007 SN0315 06aug01 HF=005 JC=3 CB=3 MD=5 DF=05000 RNA=1 rev 3.0a
cs=22486 &=0 os=
```

or the text below for CSAT3s running embedded code version 4 or greater,

```
SN0315 02mar04 rev 4.0s &=0 AC=1 AF=050 AH=1 AO=00300 ar=0 AQ= 20 BR=0 BX=0
CF=1 C0o= 0 0 0 C0b= 0 0 0 CA=1 CD=0 cs=25417 DC=8 dl=015 DM=c DR=03465
duty=048 DT=16240 ET= 20 FA=00050 FL=007 FX=038 GN=121a GO=00000 HA=0
HG=01560 HH=02700 KT=0 LG=00832 LH=00100 MA=-020 MS=-010 MX=0 ND=1 NI=2
ns=00223 OR=1 os=0 PD=2 RA=00020 RC=0 RF=00900 RH=015 RI=0 RS=0 RX=002
SD=0 SL=035 SR=1 ss=1 T0123=1000 TD=a TF=02600 02600 02600 TK=1 TO= 0 0 0
TP=t ts=i UX=0 WM=o WR=006 XD=d xp=2 XX=00875 ZZ=0.
```

where,

RS=*n* – RS-232 Synchronization code, *n* = 0 means the CSAT3 will not send the synchronization code and *n* = 1 means the CSAT3 will send the synchronization code at the end of the 10-byte RS-232 output;

BR=*n* – Baud Rate, *n* = 0 is 9600 bps and *n* = 1 is 19200 bps;

RI=*n* – Rts Independent, *n* = 0 means power the RS-232 drivers if the RTS line is asserted and *n* = 1 means to always power the RS-232 drivers;

SN*nnnn* – Serial Number of the calibration file stored in EEPROM, *nnnn* is the CSAT3 serial number;

ddmmmyy – date that the calibration file was created, *dd* is day, *mmm* is month, and *yy* is the year;

rev *n.nn* – version and revision of the embedded code, *n.nn* is the version and revision number, e.g. 3.0a.

“?d” – Output the summary diagnostics.

“sd *n*” – Enable or disable the computation of the Summary Diagnostics; where *n* = 0 means do not tabulate the summary diagnostic and *n* = 1 means clear the current summary diagnostics and start a new tabulation.

“rs *n*” – Toggle between sending a RS-232 Synchronization code; where *n* = 0 means do not send the RS-232 synchronization code and *n* = 1 means send the RS-232 synchronization code (AA55 hex) at the end of each RS-232 10-byte output. As customary for the DOS environments, the least significant byte (55 hex) of the two-byte word is transferred first.

“br *n*” – Toggle the Baud Rate between 9600 and 19200; where *n* = 0 is 9600 and *n* = 1 is 19200. Note, the baud rate is not changed until the RTS line is deasserted, e.g. RS-232 communicates have terminated. The baud rate can not

be changed if RI=1 (always power the RS-232 drivers). Check the setting of RI in the Long Status Message.

“ri n” – Toggle Rts Independent; where $n = 0$ means power the RS-232 drivers if RTS is asserted and $n = 1$ means always power the RS-232 drivers. Always powering the RS-232 drivers allows the use of short haul modems between the CSAT3 and PC.

“sr2718” – Save RAM contents, with modified calibration parameters, to non-volatile EEPROM. The command is ignored if the hardware jumper is set in normal operate mode (center and right pins). To change the hardware jumper between normal operate and save to EEPROM mode, follow the steps below.

Remove all external connectors from the CSAT3 electronics box. Place the electronics box on a workbench in front of you. Orient the electronics box such that the connectors point towards your body and the silk screening, on the CSAT3 electronics box lid, is pointing towards the ceiling. These instructions reference the location of various components as top, bottom, left, and right. The Campbell Scientific logo is in the top left corner of the electronics box lid.

Loosen the four electronics box cover retaining screws with the large Phillips screw driver. Remove the electronics box cover to gain access to the printed circuit board.

Locate the CSAT3 processor's surface-mount socket on the CPU Board. The processor is a large chip located near the center of the printed circuit board. The label on the processor will have the Campbell Scientific logo on it as well as the embedded code version number.

Locate the row of three pins above and a little to the left of the processor. These pins run from left to right and there is a movable jumper connecting the center pin and the right pin. Note, be sure to return the jumper to the normal operating position, center and right pins.

When the jumper is on the center and right pins, the CSAT3 is in the normal operate mode. When the jumper is on the left and center pins, the CSAT3 is in the save to EEPROM mode.

Appendix A. CSAT3 Orientation

A.1 Determining True North and Sensor Orientation

The orientation of the CSAT3 negative x-axis is found by reading a magnetic compass and applying the site-specific correction for magnetic declination; where the magnetic declination is the number of degrees between True North and Magnetic North. Magnetic declination for a specific site can be obtained from a USGS map, local airport, or through a NOAA web calculator (Section A.2). A general map showing magnetic declination for the Conterminous United States in 2004 is shown in Figure A-1.

Magnetic Declination for the U.S. 2004

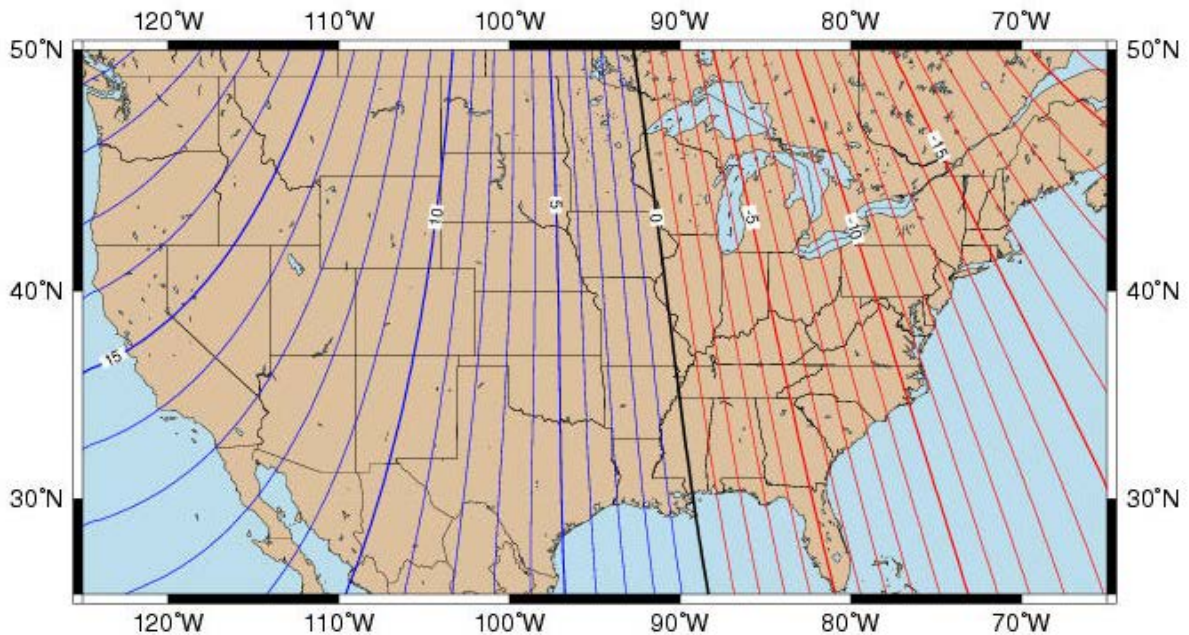

Mercator Projection

Contours of Declination of the Earth's magnetic field. Contours are expressed in degrees.
Contour Interval: 1 Degree (Positive declinations in blue, negative in red)

Produced by NOAA's National Geophysical Data Center (NGDC), Boulder, Colorado

<http://www.ngdc.noaa.gov>

Based on the International Geomagnetic Reference Field (IGRF), Epoch 2000 updated to December 31, 2004

The IGRF is developed by the International Association of Geomagnetism and Aeronomy (IAGA), Division V

FIGURE A-1. Magnetic Declination for the Conterminous United States (2004)

Declination angles are always subtracted from the compass reading to find True North. A declination angle East of True North is reported as positive a value and is subtracted from 360 (0) degrees to find True North as shown Figure A-2. A declination angle West of True North is reported as a negative value and is also subtracted from 0 (360) degrees to find True North as shown in Figure A-3. Note that when a negative number is subtracted from a positive number, the resulting arithmetic operation is addition.

For example, the declination for Longmont, CO (10 June 2006) is 9.67° , thus True North is $360^\circ - 9.67^\circ$, or 350.33° as read on a compass. Likewise, the declination for Mc Henry, IL (10 June 2006) is -2.68° , and True North is $0^\circ - (-2.68^\circ)$, or 2.68° as read on a compass.

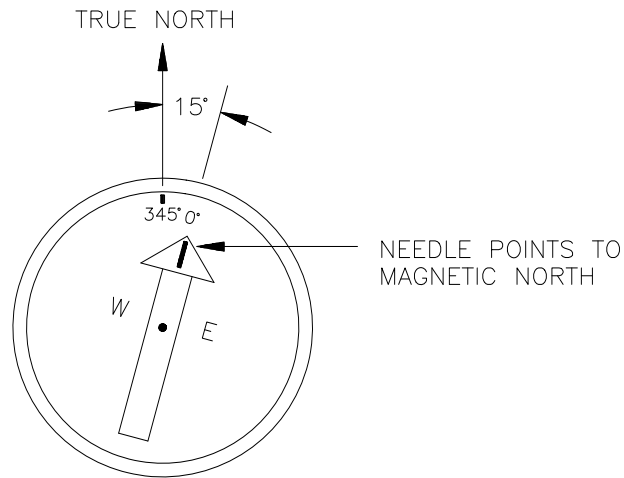

FIGURE A-2. A Declination Angle East of True North (Positive) is Subtracted from 360 (0) degrees to Find True North

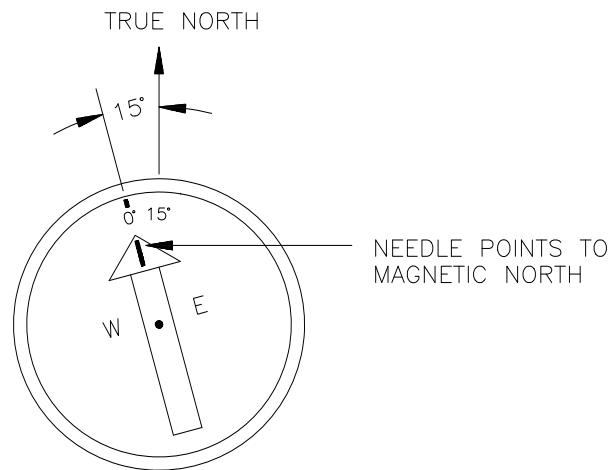
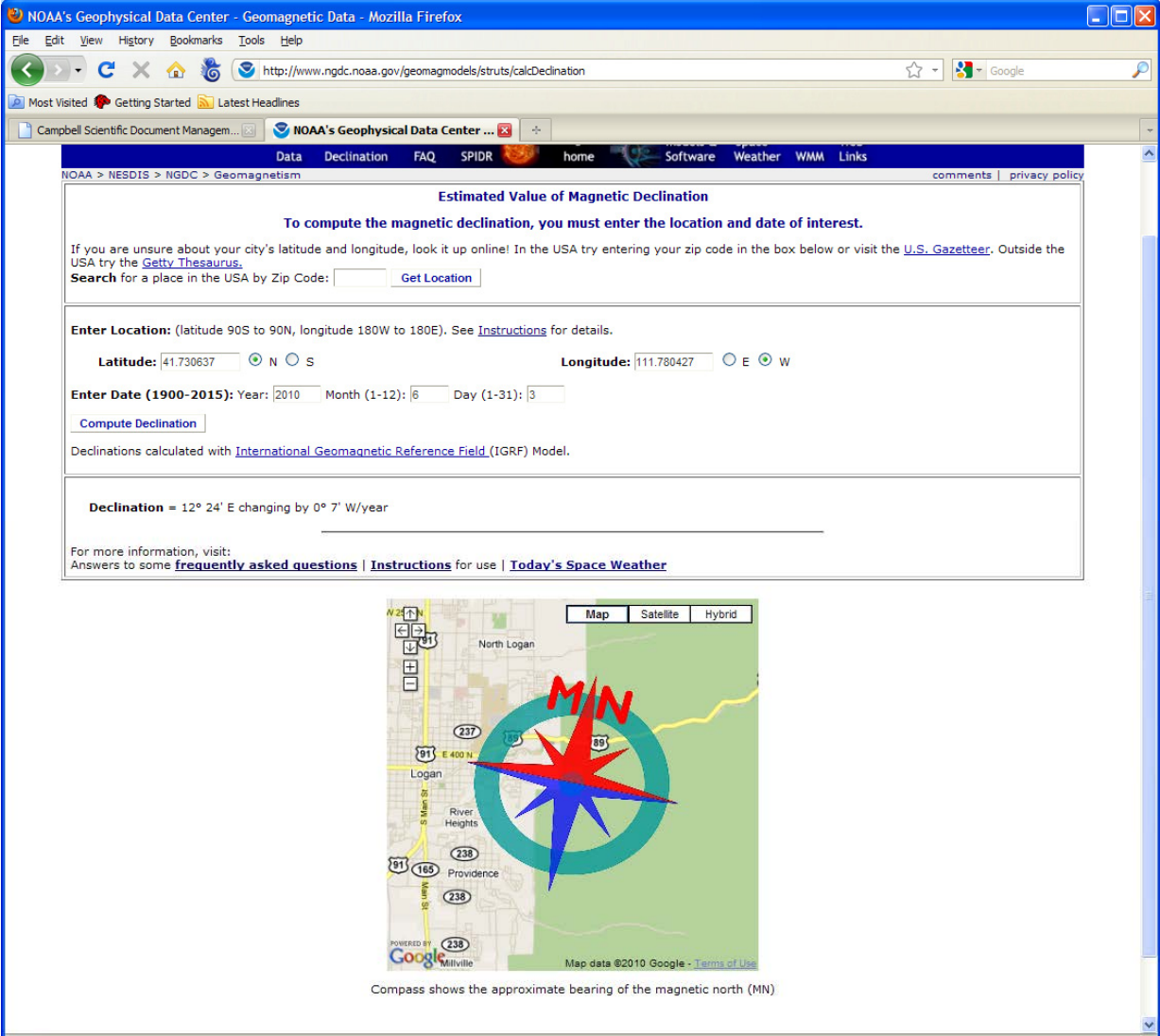

FIGURE A-3. A Declination Angle West of True North (Negative) is Subtracted from 0 (360) degrees to Find True North

A.2 Online Magnetic Declination Calculator

The magnetic declination calculator web calculator published by NOAA's Geophysical Data Center is available at the following url: www.ngdc.noaa.gov/geomagmodels/Declination.jsp. After the web page loads, enter the site zip code, or longitude and latitude, then click on the "Compute Declination" button (Figure A-4).



NOAA's Geophysical Data Center - Geomagnetic Data - Mozilla Firefox

File Edit View History Bookmarks Tools Help

http://www.ngdc.noaa.gov/geomagmodels/struts/calcDeclination

NOAA's Geophysical Data Center ...

Data Declination FAQ SPIDR home Software Weather WMM Links

NOAA > NESDIS > NGDC > Geomagnetism

Estimated Value of Magnetic Declination

To compute the magnetic declination, you must enter the location and date of interest.

If you are unsure about your city's latitude and longitude, look it up online! In the USA try entering your zip code in the box below or visit the [U.S. Gazetteer](#). Outside the USA try the [Getty Thesaurus](#).

Search for a place in the USA by Zip Code:

Enter Location: (latitude 90S to 90N, longitude 180W to 180E). See [Instructions](#) for details.

Latitude: N S **Longitude:** E W

Enter Date (1900-2015): Year: Month (1-12): Day (1-31):

Declinations calculated with [International Geomagnetic Reference Field \(IGRF\)](#) Model.

Declination = 12° 24' E changing by 0° 7' W/year

For more information, visit:
Answers to some [frequently asked questions](#) | [Instructions](#) for use | [Today's Space Weather](#)

Map Satellite Hybrid

North Logan

Logan

River Heights

Providence

Milville

Map data ©2010 Google - [Terms of Use](#)

Compass shows the approximate bearing of the magnetic north (MN)

FIGURE A-4. USGS Web Calculator

The declination for Logan, UT is 12.4 degrees (3 June 2010). As shown in Figure A-4, the declination for Utah is positive (east of north), so true north for this site is $360 - 12.4$, or 347.6 degrees. The annual change is -7 minutes/year or 7 minutes west per year.

Appendix B. Serial Communications with the CSAT3

B.1 CSAT3 RS-232 Commands

The CSAT3 powers up its RS-232 drivers when it detects that the RTS (request to send) line has been asserted by the PC. All RS-232 communications begin with the PC asserting the RTS line, the CSAT3 responds by asserting the CTS (clear to send) line. The PC must keep the RTS line asserted as long as it is communicating with the CSAT3.

RS-422 communications and short-haul modems do not include an RTS signal. The CSAT3s RS-232 drivers can be asserted by a software setting in the CSAT3. This setting will always power the RS-232 drivers, independent of the RTS line.

The unprompted output mode (Table B-1) complicates anemometer data processing software, because the original output format contains no fixed pattern to delimit the CSAT3's 10 byte output record. To configure the CSAT3 to output 12-byte records, with the last two bytes being a fixed pattern of AA55 hex, send an "rs n", where n = 0 (default) means no synchronization code and n = 1 means send the synchronization code, to the CSAT3. As is customary in the DOS environment, 55 hex is transmitted first followed by AA hex. This configuration will be lost if the CSAT3 power is cycled. To save this configuration into non-volatile memory, issue the "sr2718" command (See Section 12).

There are nine commands that may be sent to the CSAT3 over the RS-232 interface. These commands are described below. Before continuing on, read the section that describes the CSAT3 Trigger (Section 8).

TABLE B-1. RS-232 Command Codes

Command	Trigger before Command	Description	Trigger after Command
&	PC or CSAT3 timer	Unprompted data output mode. Send data and make measurements at the rate specified by the An command.	CSAT3 timer
P ¹	CSAT3 timer or PC	Send the RS-232 status (Table B-9) and trigger the next measurement now.	PC ²
U ¹	CSAT3 timer or PC	Send wind data and trigger the next measurement now.	PC ²
S	PC or CSAT3 timer	Send the RS-232 status (Table B-9). The next measurement will be made in sync with the CSAT3 timer.	CSAT3 timer
W	PC or CSAT3 timer	Send the wind data. The next measurement will be made in sync the CSAT3 timer.	CSAT3 timer
A(1..e) ^{1,3,4}	PC or CSAT3 timer	Begin acquiring the signals in sync with this command.	No change
O	SDM, PC, or CSAT3 timer	Turn the analog outputs off in sync with the next trigger.	No change
L	SDM, PC, or CSAT3 timer	Turn the analog outputs on with $\pm 32 \text{ m s}^{-1}$ full-scale range in sync with the next trigger	No change
H	SDM, PC, or CSAT3 timer	Turn the analog outputs on with $\pm 64 \text{ m s}^{-1}$ full-scale range in sync with the next trigger	No change

- 1 The CSAT3 will ignore this command if a datalogger (SDM) is triggering the anemometer.
- 2 After the PC takes over as the trigger source it must continue to trigger the CSAT3 at the rate specified in the Execution Parameter (An). If the CSAT3 does not receive a trigger for three seconds it will enter the Lost Trigger state. The Execution Parameter (An) will have to be issued in order for the anemometer to exit the Lost Trigger state.
- 3 Acquire signal commands.

An	Execution Parameter	An	Execution Parameter
A1	Not Used	A9	10 Hz
A2	1 Hz	Aa	12 Hz
A3	Not Used	Ab	15 Hz
A4	Not Used	Ac	20 Hz
A5	2 Hz	Ad	30 Hz
A6	3 Hz	Ae	60 Hz
A7	5 Hz	Ag	60 Hz → 10 Hz
A8	6 Hz	Ah	60 Hz → 20 Hz

- 4 The PC must send the second byte of this command (2..e) within two seconds of the first byte or the anemometer will reset itself. It will then acquire the signal using the Execution Parameter in static memory.

Nassi-Shneiderman diagrams are given in Figures B-1 and B-2 for collecting data using a PC and the RS-232 port. In Figure B-1, the PC is the Trigger Source and the data acquisition system. In Figure B-2, the anemometer is triggered by its internal timer and a PC is the data acquisition system. Use the logic in Figure B-1 when the CSAT3 is measured along with other analog/digital signals.

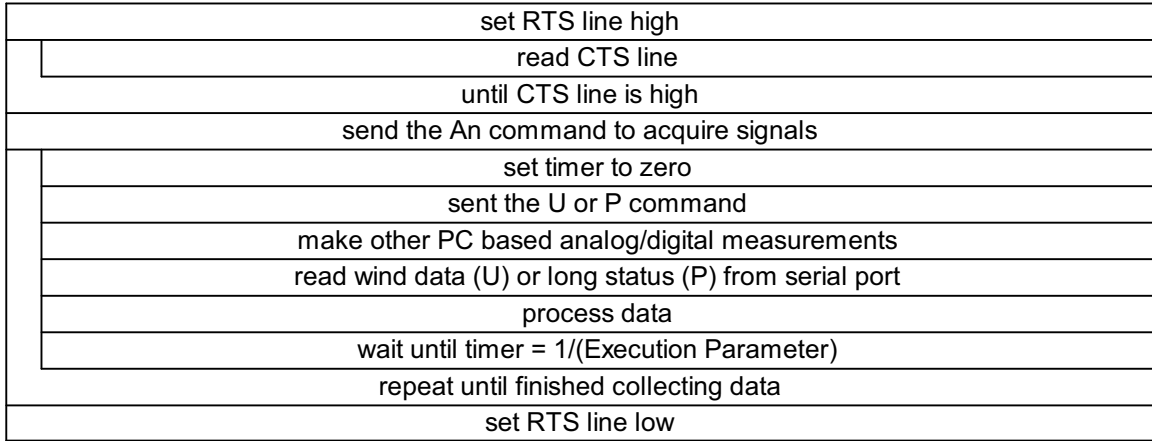

FIGURE B-1. PC as the Trigger Source

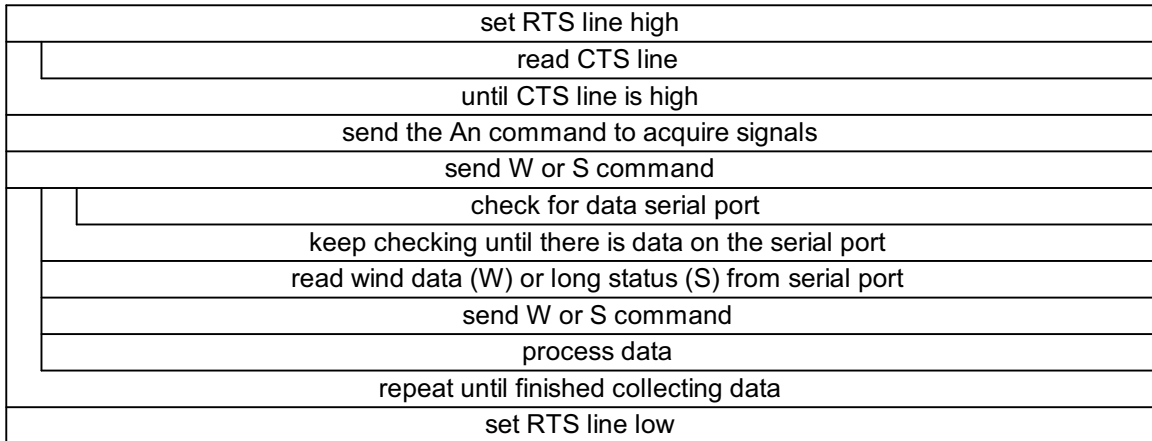

FIGURE B-2. CSAT3 as the Trigger Source

B.2 CSAT3 Binary Data Output Format

Five words are sent by the CSAT3's RS-232 output. Words 0 through 3 are 16 bit signed integers and word 4 is 16 bit unsigned integer. The five words are sent starting with word 0 and ending with word 4. A description of each word is given in Table B-2.

TABLE B-2. RS-232 Output

Word 0	Word 1	Word 2	Word 3	Word 4				
b15 - b0	b15 - b0	b15 - b0	b15 - b0	b15 b14 b13 b12	b11 b10	b09 b08	b07 b06	b05 - b00
u _x wind	u _y wind	u _z wind	c	diagnostic flags	u _x range	u _y range	u _z range	counter

B.3 Words 0 through 3

The u_x, u_y, and u_z wind speeds are reported on one of four different ranges. This range is given by bits b11 through b06 in word 4. In order to decode the wind speed, first look at the wind speed range code, then decode the data with the appropriate equations given in Tables B-3 through B-6. The data in words 0 through 3 must first be converted into a base 10 representation before applying the equations in Table B-3 through B-6.

TABLE B-3. Converting u_x Wind from Word 0

Range	Word 4 Range Code		Conversion	Output Resolution (mm s ⁻¹)
	b11	b10		
0	1	1	u _x wind (m s ⁻¹) = word 0 * 0.001 * 0.25	0.25
1	1	0	u _x wind (m s ⁻¹) = word 0 * 0.001 * 0.50	0.50
2	0	1	u _x wind (m s ⁻¹) = word 0 * 0.001 * 1.00	1.00
3	0	0	u _x wind (m s ⁻¹) = word 0 * 0.001 * 2.00	2.00

TABLE B-4. Converting u_y Wind from Word 1

Range	Word 4 Range Code		Conversion	Output Resolution (mm s ⁻¹)
	b09	b08		
0	1	1	u _y wind (m s ⁻¹) = word 1 * 0.001 * 0.25	0.25
1	1	0	u _y wind (m s ⁻¹) = word 1 * 0.001 * 0.50	0.50
2	0	1	u _y wind (m s ⁻¹) = word 1 * 0.001 * 1.00	1.00
3	0	0	u _y wind (m s ⁻¹) = word 1 * 0.001 * 2.00	2.00

TABLE B-5. Converting u_z Wind from Word 2

Range	Word 4 Range Code		Conversion	Output Resolution (mm s ⁻¹)
	b07	b06		
0	1	1	u _z wind (m s ⁻¹) = word 2 * 0.001 * 0.25	0.25
1	1	0	u _z wind (m s ⁻¹) = word 2 * 0.001 * 0.50	0.50
2	0	1	u _z wind (m s ⁻¹) = word 2 * 0.001 * 1.00	1.00
3	0	0	u _z wind (m s ⁻¹) = word 2 * 0.001 * 2.00	2.00

The speed of sound reported by the CSAT3 is the average between the three sonic paths. The relationship to find the speed of sound is given in Table B-6. Word 3 must be converted to a base 10 representation before applying the equation.

Conversion	Output Resolution	
	(mm s ⁻¹)	(°C @ 25°C)
speed of sound (m s ⁻¹) = word 3 * 0.001 + 340.0	1	0.0017

B.4 Word 4

Word 4 contains diagnostic information and the reporting range of u_x , u_y , and u_z wind speed. The diagnostic flags, bits b15 through b12, describe the status of the anemometer (Table B-7). A flag is on if the bit is set high. All the flags are on while the anemometer is acquiring signals or is in a lost trigger state (Table B-8).

Bit Set High	Description	Comment
b15	Difference in the speed of sound between the three non orthogonal axes is greater than 2.360 m s ⁻¹ (~ 4°C @ 25°C)	The anemometer path length may have been altered or the anemometer head is broken.
b14	Poor signal lock	There may be an obstruction in the anemometer path or on the transducer face.
b13	Sonic signal amplitude too high	An obstruction, in the anemometer path or on the transducer face, was removed.
b12	Sonic signal amplitude too low	There may be an obstruction in the anemometer path or on the transducer face.

Bits b11 through b06 are used in determining the range of the wind speed reported in words 0 through 2.

Bits b05 through b00 are a diagnostic counter. This counter increments once per measurement. The minimum value is 0 and the maximum is 63. The counter wraps from 63 to 0 when the maximum value is incremented by one.

Not a Number Conditions	Word 0		Word 1		Word 2		Word 3		Word 4	
	hex	base 10	hex	base 10	hex	base 10	hex	base 10	hex	base 10
Not Available	8000	-32768	8000	-32768	8000	-32768	8000	-32768	F03F	61503
Lost Trigger	8000	-32768	8000	-32768	8000	-32768	8000	-32768	F000	61440

B.5 CSAT3 RS-232 Status Format

The CSAT3 returns a 10 ASCII byte status in response to a “S” or “P” command. This status provides information on the CSAT3’s Trigger Source and the Execution Parameter. It also indicates if the analog outputs are on/off, if the CSAT3 is reporting good data, and serial number of the CSAT3. This software serial number matches those on the anemometer head and electronics box.

TABLE B-9. RS-232 Status, Response to the S or P Command				
Byte	Description	Value		
0	Trigger Source	0 = CSAT3 Timer	1 = PC	2 = SDM
1	Execution Parameter	see Table B-1		
2	Analog Range	0 = Off	1 = $\pm 32 \text{ m s}^{-1}$	2 = $\pm 64 \text{ m s}^{-1}$
3	Data Status	0 = Good Data	1 = Acquiring Signals	2 = Lost Trigger
4	Terminal Mode	D = Normal Mode	T = CSI Mode	
5-8	CSAT3 Serial Number			
9	P or U	P = Prompted	U = Unprompted	

Appendix C. CSAT3 Measurement Theory

C.1 Theory of Operation

C.1.1 Wind Speed

Each axis of the CSAT3 pulses two ultrasonic signals in opposite directions. The time of flight of the first signal (out) is given by:

$$t_o = \frac{d}{c + u_a} \quad (1)$$

and the time of flight of the second signal (back) is given by:

$$t_b = \frac{d}{c - u_a} \quad (2)$$

where t_o is the time of flight out along the transducer axis, t_b is the time of flight back, in the opposite direction, u_a is the wind speed along the transducer axis, d is the distance between the transducers, and c is the speed of sound.

The wind speed, u_a , along any axis can be found by inverting the above relationships, then subtracting Eq. (2) from (1) and solving for u_a .

$$u_a = \frac{d}{2} \left[\frac{1}{t_o} - \frac{1}{t_b} \right] \quad (3)$$

The wind speed is measured on all three non-orthogonal axis to give u_a , u_b , and u_c , where the subscripts a, b, and c refer to the non-orthogonal sonic axis.

The non-orthogonal wind speed components are then transformed into orthogonal wind speed components, u_x , u_y , and u_z , with the following:

$$\begin{bmatrix} u_x \\ u_y \\ u_z \end{bmatrix} = A \begin{bmatrix} u_a \\ u_b \\ u_c \end{bmatrix} \quad (4)$$

where A is a 3 x 3 coordinate transformation matrix, that is unique for each CSAT3 and is stored in ROM memory.

C.1.2 Temperature

The sonically determined speed of sound can be found from the sum of the inverses of Eq. (1) and (2). The CSAT3 corrects online for the effect of wind

blowing perpendicular to the sonic path. No additional off-line corrections are required as suggested by Liu et al., 2001.

$$c = \frac{d}{2} \left[\frac{1}{t_o} + \frac{1}{t_b} \right] \quad (5)$$

The speed of sound in moist air is a function of temperature and humidity and is given by:

$$c^2 = \gamma P / \rho = \gamma R_d T_v = \gamma R_d T (1 + 0.61q) \quad (6)$$

where γ is the ratio of specific heat of moist air at constant pressure to that at constant volume, P is pressure, ρ is air density, R_d is the gas constant for dry air, T_v is virtual temperature, T is the air temperature, and q is the specific humidity defined as the ratio of the mass of water vapor to the total mass of air (Kaimal and Gaynor, 1991; Wallace and Hobbs, 1977).

Note that γ is a function of specific humidity. It would be convenient if the effects of humidity could be consolidated into one term.

The specific heats for moist air at constant pressure and volume are given by:

$$\begin{aligned} C_p &= qC_{pw} + (1 - q)C_{pd} \\ &= C_{pd}(1 + 0.84q) \end{aligned} \quad (7a)$$

$$\begin{aligned} C_v &= qC_{vw} + (1 - q)C_{vd} \\ &= C_{vd}(1 + 0.93q) \end{aligned} \quad (7b)$$

where C_p and C_v are the specific heats of moist air at constant volume and pressure, C_{pw} and C_{vw} is the specific heat of water vapor, and C_{pd} and C_{vd} is the specific heat of dry air, respectively (Fleagle and Businger, 1980).

Substitute Eq. (7a) and (7b) into (6) and ignore the higher order terms. This yields

$$c^2 = \gamma_d R_d T_s = \gamma_d R_d T (1 + 0.51q) \quad (8)$$

where T_s is sonic virtual temperature and γ_d is the ratio of specific heat of dry air at constant pressure to that at constant volume (Fleagle and Businger, 1980; Kaimal and Gaynor, 1991; Kaimal and Businger, 1963; Schotanus et al., 1983). With Eq. (8), the effect of humidity, on the speed of sound, is included in the sonic virtual temperature.

The sonic virtual temperature, in degrees Celsius, is given by Eq. (9), where $\gamma_d = 1.4$ and $R_d = 287.04 \text{ JK}^{-1} \text{ kg}^{-1}$.

$$T_s = \frac{c^2}{\gamma_d R_d} - 273.15 \quad (9)$$

REFERENCES

- Kaimal, J. C. and Businger, J. A.: 1963, "A Continuous Wave Sonic Anemometer-Thermometer", *J. Applied Meteorol.*, **2**, 156-164.
- Kaimal, J. C. and Gaynor, J. E.: 1991, "Another Look at Sonic Thermometry", *Boundary-Layer Meteorol.*, **56**, 401-410.
- Fleagle, R. G. and Businger, J. A.: 1980, *An Introduction to Atmospheric Physics*, Academic Press, Inc., New York.
- Liu, H., Peters, G., and Foken, T.: 2001, "New Equations for Sonic Temperature Variance and Buoyancy Heat Flux with an Omnidirectional Sonic Anemometer", *Boundary-Layer Meteorol.*, **100**, 459-468.
- Schotanus, P., Nieuwstadt, F. T. M., and de Bruin, H. A. R.: 1983, "Temperature Measurement with a Sonic Anemometer and its Application to Heat and Moisture Fluxes", *Boundary-Layer Meteorol.*, **26**, 81-93.
- Wallace, J. M. and Hobbs, P. V.: 1977, *Atmospheric Science an Introductory Survey*, Academic Press, Inc., New York.

Appendix D. SDM Communications and Long Signal Cables

D.1 Brief Description of SDM Clock Rates

The fastest rate that a datalogger and SDM sensors can communicate via the SDM bus is determined by the number of SDM sensors connected to the SDM bus, properties of the cable used to connect the sensors (resistance and capacitance), and the scan interval. This rate, called the SDM clock rate, has been optimized for the standard 7.62 m (25 ft.) SDM signal and power cable supplied with the CSAT3. The CSAT3() and SDMTrigger() on the CR3000, CR1000, CR5000, CR800/850, and CR9000(X), and the SDM-CSAT3 (P107) and SDM Group Trigger (P110) on the CR23X, 21X, and CR10(X), use this optimum SDM clock rate by default. For cases when longer lead lengths are required, the SDM clock rate may be slowed down using Instruction SDMSpeed () (CRBasic dataloggers) or Set SDM Clock (P108 for a 21X and P115 for a CR23X and CR10(X)). The SDM Clock rate is changed by entering a bit period for the CRBasic dataloggers or a parameter between 1 and 255, where 1 is the fastest SDM clock rate and 255 is the slowest, for the EDLOG dataloggers.

Campbell Scientific has written a datalogger program that will find the appropriate SDM clock rate for a given system configuration. The example programs start with the default SDM clock rate and systematically slow the rate down until there are no SDM communication errors. They then begin to speed up the rate until SDM communications fails. The processes of slowing down and speeding up the SDM clock rate around the fail threshold continues for approximately three minutes.

The CRBasic dataloggers output a single data table called “report”. The fastest SDM clock rate, that can be used with a particular system setup, can be found from the “All_Fail_Tot” element by selecting the first bit period with zero failures. To provide a safety margin select the next slowest bit period. Test the new SDM clock rate in the datalogger program that will be used during the experiment.

The EDLOG dataloggers output three arrays. The first (array ID = 150) is the SDM parameter, the second (array ID = 151) is the number of failures at a SDM parameter as a percent of attempts at that SDM parameter, and the third (array ID = 152) is the number of attempts at a SDM parameter. The fastest SDM clock rate, that can be used with a particular system setup, can be found from the failure array by selecting the first clock parameter with zero failures. To provide a safety margin select the next slowest clock parameter. Test the new SDM clock rate in the datalogger program that will be used during the experiment.

Copies of the SDM search programs for the CRBasic and EDLOG dataloggers (Section D.1 and D.2) are available on the Campbell Scientific web site in the Support/Downloads section. Run these programs if the datalogger is having problems communicating with CSAT3 (Section 10.4).

D.2 CR3000 Example

Connect all the SDM devices to the datalogger with the cable in question. Download the example CRBasic SDM search program to the datalogger. This program will test the SDM communications between a CRBasic datalogger and a CSAT3, LI-7500, or both a CSAT3 and LI-7500. After the program compiles, use the CRBasic keyboard and set the menu items “Test CSAT3?” and “Test LI-7500?” to the appropriate values. To start the test, set the menu item “Start Test?” to “Yes”. The test is complete when the menu item “Start Test?” is reset to “No”. The test makes about 3,000 attempts to communicate with the SDM devices. With the CR3000 and CR5000 the test takes about 5 minutes to complete. With the CR1000 the test takes about 25 minutes to complete. To terminate the test before the test is complete, set the menu option “Start Test?” to “No”. Collect the data table “report”.

Take the following case, a 100 m (328.1 ft) SDM signal and power cable is used to connect a CR3000 datalogger and a single CSAT3 anemometer. Communication between the CR3000 and CSAT3 fails at the default SDM bit period of 30 μ Sec. Thus, a longer SDM bit period (slower SDM clock rate) must be used. The example CR3000 SDM clock rate search program generated the data in Table D-1.

**TABLE D-1. Data from Example CR3000
SDM Clock Rate Search Program**

TOA5, CR3000_usb, CR3000, 1138, CR3000.Std.05.02, CPU:Sdm_cr3kv1_3.cr3, 21566, report

RECORD	SDM_Period	All_Fail_Tot	CSAT_sig_Tot	CSAT_NaN_Tot	IRGA_sig_Tot	IRGA_NaN_Tot	Number_Attempts	CSAT3	LI-7500
RN	uSec	samples	samples	samples	samples	samples	unitless	Smp	Smp
	Smp	Smp	Smp	Smp	Smp	Smp	Smp	Smp	Smp
0	30	2	2	0	0	0	2984	1	0
1	40	0	0	0	0	0	2	1	0
2	50	0	0	0	0	0	2	1	0
3	60	0	0	0	0	0	2	1	0

From the results in Table D1, the shortest bit period (fastest SDM clock rate) that the SDM bus could run, without encountering communication errors, would be with a bit period of 40 μ Sec. However, to have a safety margin, a value of 50 μ Sec is used for the SDM bit period.

The SDM bit period was set to 50 μ Sec and tested the system program. The test showed that using a SDM bit period of 50 μ Sec, in the SDMSpeed () instruction, did not cause the CR3000 to skip scans (Status Table), thus the SDM bit period is left at parameter 50 μ Sec.

D.3 CR23X Example

Connect all the SDM devices to the datalogger with the cable in question. Download the example CR23X SDM search program to the datalogger, after the program compiles, set Flag 3 high to begin the experiment. When Flag 2 is set low the experiment is complete. The test makes 3,600 attempts to communicate with the SDM device at a frequency of 10 Hz. The test takes 3 minutes to run. Collect the data from the datalogger and run the example SPLIT parameters files, SDM_TRAN.PAR and SDM.PAR, to sort the data. Identify the correct SDM clock parameter to use for your system configuration from the report generated by the SPLIT parameter file SDM.PAR.

Take the following case, a 575 foot SDM signal and power cable is used to connect a CR23X datalogger and a single CSAT3 anemometer. Communication between the CR23X and CSAT3 fails at the default SDM clock rate. Thus, a slower SDM clock rate must be used. The example CR3X SDM clock rate search program generated the data in Table D-2.

TABLE D-2. Data from Example CR23X SDM Clock Rate Search Program		
150,1,2,3,4,5,6,7,8,9,10,11,12,13,14,15,16, ... ,253,254,255		
151,100,99999,99999,100,99999,99999,100,99999,100,96,0,0,0,99999,99999,99999, ... ,99999,99999,99999		
152,1,0,0,1,0,0,1,0,17,450,449,449,432,0,0,0, ... ,0,0,0		

Run the SPLIT parameter file SDM_TRAN.PAR on the above data set to transpose the data into columns.

Now run the SPLIT parameter file SDM.PAR, to filter out the SDM clock parameters that were not tested, 99999 in array 151. This parameter file also creates a report of the SDM clock parameters that were tested and their failure rate as a percent of attempts.

The following report was created from the above SPLIT parameter file, SDM.PAR.

TABLE D-3. SDM Clock Rate Report		
SDM Param	Failures % Attmpt	Attempts
1	100	1
4	100	1
7	100	1
9	100	17
10	96	450
11	0	449
12	0	449
13	0	432

From the above results, the fastest rate that the SDM bus could run, without encountering communication errors, would be using a value of 11 for the SDM clock parameter in Instruction Set SDM Clock (P115). However, to have a safety margin, a value of 12 is used.

The SDM parameter was set to 12 and tested the eddy covariance program. The test showed that using SDM parameter of 12, in the Set SDM Clock (P115), did not cause the CR23X to overrun the Tables (*B mode), thus the SDM Clock parameter is left at 12.

Campbell Scientific Companies

Campbell Scientific, Inc. (CSI)

815 West 1800 North
Logan, Utah 84321
UNITED STATES
www.campbellsci.com • info@campbellsci.com

Campbell Scientific Africa Pty. Ltd. (CSAf)

PO Box 2450
Somerset West 7129
SOUTH AFRICA
www.csafrica.co.za • cleroux@csafrica.co.za

Campbell Scientific Australia Pty. Ltd. (CSA)

PO Box 444
Thuringowa Central
QLD 4812 AUSTRALIA
www.campbellsci.com.au • info@campbellsci.com.au

Campbell Scientific do Brazil Ltda. (CSB)

Rua Luisa Crapsi Orsi, 15 Butantã
CEP: 005543-000 São Paulo SP BRAZIL
www.campbellsci.com.br • suporte@campbellsci.com.br

Campbell Scientific Canada Corp. (CSC)

11564 - 149th Street NW
Edmonton, Alberta T5M 1W7
CANADA
www.campbellsci.ca • dataloggers@campbellsci.ca

Campbell Scientific Centro Caribe S.A. (CSCC)

300 N Cementerio, Edificio Breller
Santo Domingo, Heredia 40305
COSTA RICA
www.campbellsci.cc • info@campbellsci.cc

Campbell Scientific Ltd. (CSL)

Campbell Park
80 Hathern Road
Shepshed, Loughborough LE12 9GX
UNITED KINGDOM
www.campbellsci.co.uk • sales@campbellsci.co.uk

Campbell Scientific Ltd. (France)

3 Avenue de la Division Leclerc
92160 ANTONY
FRANCE
www.campbellsci.fr • info@campbellsci.fr

Campbell Scientific Spain, S. L.

Avda. Pompeu Fabra 7-9, local 1
08024 Barcelona
SPAIN
www.campbellsci.es • info@campbellsci.es

Please visit www.campbellsci.com to obtain contact information for your local US or International representative.