

INSTRUCTION MANUAL

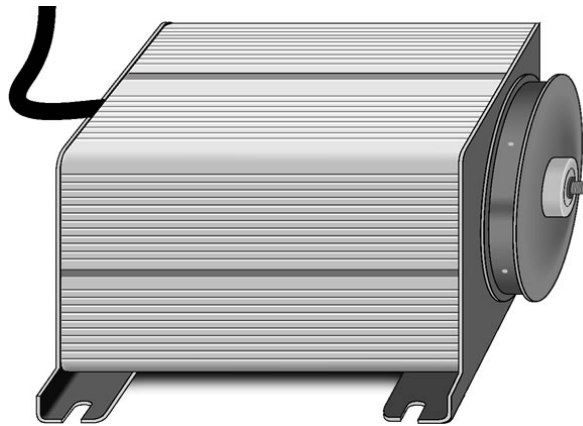

CS410 Shaft Encoder

Revision: 3/06



Copyright © 1999-2006
Campbell Scientific, Inc.

WARRANTY AND ASSISTANCE

This equipment is warranted by CAMPBELL SCIENTIFIC (CANADA) CORP. ("CSC") to be free from defects in materials and workmanship under normal use and service for **twelve (12) months** from date of shipment unless specified otherwise. ***** **Batteries are not warranted.** ***** CSC's obligation under this warranty is limited to repairing or replacing (at CSC's option) defective products. The customer shall assume all costs of removing, reinstalling, and shipping defective products to CSC. CSC will return such products by surface carrier prepaid. This warranty shall not apply to any CSC products which have been subjected to modification, misuse, neglect, accidents of nature, or shipping damage. This warranty is in lieu of all other warranties, expressed or implied, including warranties of merchantability or fitness for a particular purpose. CSC is not liable for special, indirect, incidental, or consequential damages.

Products may not be returned without prior authorization. To obtain a Return Merchandise Authorization (RMA), contact CAMPBELL SCIENTIFIC (CANADA) CORP., at (780) 454-2505. An RMA number will be issued in order to facilitate Repair Personnel in identifying an instrument upon arrival. Please write this number clearly on the outside of the shipping container. Include description of symptoms and all pertinent details.

CAMPBELL SCIENTIFIC (CANADA) CORP. does not accept collect calls.

Non-warranty products returned for repair should be accompanied by a purchase order to cover repair costs.



CAMPBELL SCIENTIFIC
C A N A D A C O R P .

11564 - 149 street - edmonton - alberta - T5M 1W7
tel 780.454.2505 fax 780.454.2655

www.campbellsci.ca

CS410 Table of Contents

PDF viewers note: These page numbers refer to the printed version of this document. Use the Adobe Acrobat® bookmarks tab for links to specific sections.

1. General	1
2. Specifications	1
3. Wiring.....	1
4. Installation.....	1
5. Programming	2
5.1 CR10X Edlog Program Example.....	2
5.2 Entering the Reference Offset for Edlog Program.....	4
5.3 CR1000 CRBasic Program Example	4

CS410 Shaft Encoder

1. General

Shaft encoders monitor fluctuations in water level and the position of water control gates by converting shaft rotation to electronic signals which are then measured by the datalogger.

The CS410 generates two pulse strings—one indicating clockwise and the other counter-clockwise rotation.

2. Specifications

Compatible Dataloggers: CR200-series, CR10(X), CR500, CR510, 21X, CR23X, CR7, CR1000, CR3000

Power supply: 4 to 5.6 volts

Operating temperature: -25 to +50°C

Resolution: 100 counts per revolution

Shaft diameter: 5/16 inch

Maximum cable length: 100 ft (30 m)

Current drain: 0.5 mA

Starting torque: less than 0.125 in oz.

Minimum time between input transitions: 0.75 ms

Output pulse width: 0.25 ms at 25 degrees C

Signal magnitude, Volts: 0 (low), supply voltage (high)

Dimensions (L x W x D, inches): 7 x 4.875 x 4

Weight: 1.8 lbs.

3. Wiring

Black ----- GND

Red----- 5V

Green ----- P2

White ----- P1

Shield----- GND

4. Installation

Shaft encoders are typically mounted in a stilling well for protection and to dampen waves. Attach the pulley to the CS410. If you have our pulley, part # 10799, it is secured with a 9/64" hex wrench. Mount the encoder in the stilling well allowing for the pulley and tape to be unobstructed. Attach the end hooks to the tape, followed by the float and counter weight. Then drape the tape over the pulley.

5. Programming

The shaft encoder is measured with Instruction 3.

Multiplier for Instruction 3:

The multiplier is based on the wheel circumference and the shaft encoder counts per revolution:

$$\text{MULTIPLIER} = \text{WHEEL CIRCUM. (in desired units)} / (\text{COUNTS/REV.})$$

The CS410 has 100 counts/revolution, thus with a 1-foot circumference wheel:

$$\text{MULTIPLIER} = 1/100 = .01 \text{ (measures in feet)}$$

5.1 CR10X Edlog Program Example

This program collects and processes data; additional instructions are required to send the data to final storage. The data must be in final storage to transfer the data to a storage module or to retrieve the data via a telecommunications link.

```

CR10(X) Program for the CS410:

*Table 1 Program
  1:  5           Execution Interval (seconds)

1: Pulse (P3)
  1:  1           Reps
  2:  1           Pulse Channel 1
  3:  0           High Frequency, All Counts
  4:  1           Loc [ count_up ]
  5:  1           Mult
  6:  0           Offset

2: Pulse (P3)
  1:  1           Reps
  2:  2           Pulse Channel 2
  3:  0           High Frequency, All Counts
  4:  2           Loc [ count_dwn ]
  5:  1           Mult
  6:  0           Offset

;PROCESSING INSTRUCTIONS

3: Z=F (P30)
  1: 100          F           ;pulses per revolution
  2:  0           Exponent of 10
  3:  3           Z Loc. [ _100 ]

4: Z=F (P30)
  1:  1           F           ;pulley circumference (1 foot)
  2:  0           Exponent of 10
  3:  4           Z Loc. [ circ ]
    
```

```

5: Z=X/Y (P38)
  1: 4          X Loc. [ circ  ]
  2: 3          Y Loc. [ _100  ]
  3: 5          Z Loc. [ ft_count ]      ;feet per count

6: Z=X*Y (P36)
  1: 1          X Loc [ count_up ]
  2: 5          Y Loc [ ft_count ]
  3: 1          Z Loc [ count_up ]

7: Z=X*Y (P36)
  1: 2          X Loc [ count_dwn ]
  2: 5          Y Loc [ ft_count ]
  3: 2          Z Loc [ count_dwn ]

8: Z=X+Y (P33)
  1: 1          X Loc [ count_up ]
  2: 6          Y Loc [ stage_ft ]
  3: 6          Z Loc [ stage_ft ]

9: Z=X-Y (P35)
  1: 6          X Loc [ stage_ft ]
  2: 2          Y Loc [ count_dwn ]
  3: 6          Z Loc [ stage_ft ]

;Set offset once when program compiles

10: If Flag/Port (P91)
  1: 21         Do if Flag 1 is Low
  2: 30         Then Do

11: Z=X+F (P34)
  1: 6          X Loc [ stage_ft ]
  2: 0          F          ;Enter offset here
  3: 6          Z Loc [ stage_ft ]

12: Do (P86)
  1: 11         Set Flag 1 High

13: End (P95)

*Table 2 Program
  02: 0.0000    Execution Interval (seconds)

*Table 3 Subroutines

End Program

```

After downloading the program, test the direction of the float movement by raising the float up above the water level and note the stage value. If it decreases, the direction is incorrect. This can be corrected in two ways: 1) reverse the float and counter weight on the pulley, or 2) reverse the green and white wires going into the pulse ports of the datalogger.

5.2 Entering the Reference Offset for Edlog Program

The offset, which sets the stage value equal to some reference point, should be entered after the system has been installed and the float is resting on the water surface. For a stream stage application the offset is the difference between the staff gage reading and the datalogger reading from the encoder. For example; if the staff gage reads 12.25 feet, and the datalogger reads 0.75 feet, the offset would be 11.50 feet ($12.25 - 0.75 = 11.50$).

For the example program above the offset would then be added to the program and re-downloaded, or the offset could be added using the keyboard display by entering the value in the 11th step of the program. Another option would be to use the *4 link in your program for the offset to avoid having to enter the program tables (see your datalogger manual or Edlog for details).

5.3 CR1000 CRBasic Program Example

This program collects and processes data. Output is set to report the stage level and offset at 15-minute intervals, but is easily changed if desired. Offsets to the Stage level are automatically calculated when an observed gage height is entered into the variable named "enter_obs_gage_ht". The offset and other variables are preserved in the datalogger even if power is lost to the unit. However, any changes to the stage are NOT recorded during power outages.

```
'CR1000 Series Datalogger
'CS410-L Shaft Encoder

'Declare Public Variables
PreserveVariables                                'values will be retained even if power is lost

Public enter_obs_gage_ht                          'variable where you enter observed gage height
Public old_gage_ht                                'also holding previous value for comparison
Public batt_volt
Public Stage_lvl, offset, Count(2)
Alias Count(1) = Up
Alias Count(2) = Down
Units Stage_lvl = feet                            'modify only if changing Pulley_Circ value, below

'Declare Other Variables
Dim FtPerCount

'Declare Constants
Const Pulley_circ = 1                             'foot (edit if units other than feet are desired for
'the Stage_lvl record, or if using a pulley with different circumference)
```

```

Const PulsesPerRev = 100                                     'CS410 encoder resolves 100 counts per revolution

'Define Data Tables
DataTable (Stage,1,-1)
  DataInterval (0,15,Min,10)
  Sample (1,Stage_lvl,FP2)
  Sample (1,offset,FP2)
  Minimum (1,batt_volt,FP2,0,False)
EndTable

'Main Program
BeginProg
  FtPerCount = Pulley_circ/PulsesPerRev

  Scan (5,Sec,0,0)
    Battery (Batt_volt)
    PulseCount (Count(),2,1,0,0,1.0,0)
    Stage_lvl = Stage_lvl + (Up * FtPerCount) - (Down * FtPerCount)
    'If Stage_lvl does not equal the observed gage height, simply enter
    'the actual value in the numeric display for "Enter_obs_gage_ht"

    'calculate offset when gage height is observed and entered
    'into numeric display
    If enter_obs_gage_ht <> old_gage_ht then
      offset = enter_obs_gage_ht - stage_lvl
      Stage_lvl = Stage_lvl + offset
      old_gage_ht = enter_obs_gage_ht
    endif

    'Call Output Tables
    CallTable Stage
  NextScan
EndProg

```

After downloading the program to the datalogger, test the direction of the float movement by raising the float above the water level and note the stage value. If it decreases, the direction is incorrect. This can be corrected in two ways: 1) reverse the float and counterweight on the pulley, or 2) reverse the green and white wires going into the > pulse ports of the datalogger.

Campbell Scientific Companies

Campbell Scientific, Inc. (CSI)

815 West 1800 North
Logan, Utah 84321
UNITED STATES
www.campbellsci.com
info@campbellsci.com

Campbell Scientific Africa Pty. Ltd. (CSAf)

PO Box 2450
Somerset West 7129
SOUTH AFRICA
www.csafrica.co.za
sales@csafrica.co.za

Campbell Scientific Australia Pty. Ltd. (CSA)

PO Box 444
Thuringowa Central
QLD 4812 AUSTRALIA
www.campbellsci.com.au
info@campbellsci.com.au

Campbell Scientific do Brazil Ltda. (CSB)

Rua Luisa Crapsi Orsi, 15 Butantã
CEP: 005543-000 São Paulo SP BRAZIL
www.campbellsci.com.br
suporte@campbellsci.com.br

Campbell Scientific Canada Corp. (CSC)

11564 - 149th Street NW
Edmonton, Alberta T5M 1W7
CANADA
www.campbellsci.ca
dataloggers@campbellsci.ca

Campbell Scientific Ltd. (CSL)

Campbell Park
80 Hathern Road
Shepshed, Loughborough LE12 9GX
UNITED KINGDOM
www.campbellsci.co.uk
sales@campbellsci.co.uk

Campbell Scientific Ltd. (France)

Miniparc du Verger - Bat. H
1, rue de Terre Neuve - Les Ulis
91967 COURTABOEUF CEDEX
FRANCE
www.campbellsci.fr
campbell.scientific@wanadoo.fr

Campbell Scientific Spain, S. L.

Psg. Font 14, local 8
08013 Barcelona
SPAIN
www.campbellsci.es
info@campbellsci.es