

# Shaft Encoder

## Model CS410

The CS410 is a shaft encoder designed for water level measurements by Campbell Scientific. A pulley attached to a float and counter-weight rotates as water level rises or falls, and the encoder sends two pulse strings to the datalogger. The datalogger records the pulse strings, and water level is calculated by adding and subtracting the clockwise or counter clockwise movement to a running total. The encoder resolution is 100 counts per shaft revolution, so a 1-foot circumference pulley has a resolution of 0.01 feet. Compatible dataloggers include our CR200-series, CR800-series, CR510, CR10X, CR1000, and CR3000.

A complete measurement system requires a float, pulley, float tape or beaded float line, end hooks, appropriate-sized counter weight, and datalogger. See supporting equipment below for offerings from Campbell Scientific.

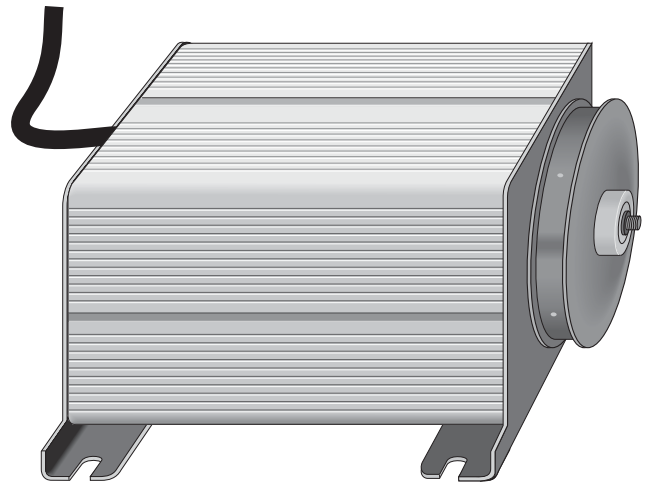

### Ordering Information

CS410-L Orders an encoder and interface cable. Enter lead length for signal cable in feet after the L.

### Specifications

Temperature:	-25° to +50°C (Note: Not responsive if water surface freezes)	Starting torque:	Less than 0.125 inch-ounces
Dimensions (L x W x D):	7" x 4.875" x 4" (18 x 12.4 x 10 cm)	Power Supply:	4 to 5.6 V
Weight:	1.8 lbs (0.82 kg)	Current Drain:	0.5 mA
Shaft size:	5/16" (0.8 cm) OD	Minimum time between input transitions:	0.75 ms
Thread count:	24 per inch	Output Pulse Width:	0.25 ms at 25°C
Resolution:	100 counts/revolution	Signal Magnitude (Volts):	0 (low), supply voltage (high)
Maximum cable length:	100 ft (30 m)		

### Supporting equipment available from Campbell Scientific

12221	Polyethylene float, 6" diameter	10803	Counter weight, 4 oz
10801	Float tape, punched on 2.4" center	12225	Counter weight, 8 oz
12222	End hooks for punched tape (2 required)	10799	Plastic pulley, 1 ft circumference (0.01 ft resolution)

