

- Heat resistant instrument design
- Extended operating temperature range
- Excellent temperature dependency
- Built-in Pt-100 temperature sensor
- High irradiance measurement capacity

IRRADIANCE MEASUREMENTS AT HIGH TEMPERATURES

With an operating temperature range of $-40\text{ }^{\circ}\text{C}$ to $+150\text{ }^{\circ}\text{C}$ and measurement up to 4000 W/m^2 it is a unique product. All the radiometer components are specially selected for their ability to withstand these extremely high temperatures and irradiance. The CM 4 is supplied as standard with a 10 m signal cable, optionally a 25 m cable can be factory fitted to the instrument.

The CM 4 High Temperature Pyranometer has internal first-order temperature compensation, but it is also supplied with a built in Pt-100 temperature sensor to provide additional information on the measurement conditions. Optionally the instrument can be supplied with a graph of the radiometer temperature dependence of sensitivity. Monitoring the temperature during operations allows easy data correction afterwards for improved measurement accuracy.

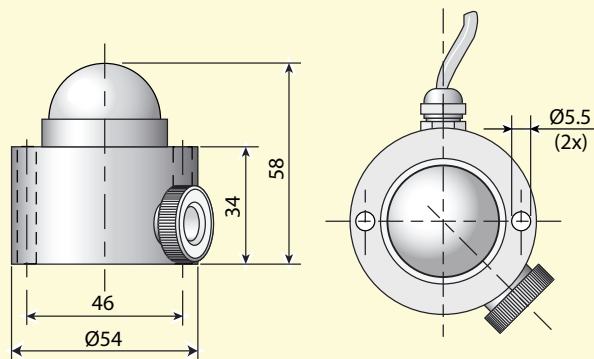

The CM 4 High Temperature Pyranometer is a radiometer specially designed for measuring solar or artificial light irradiance under the most extreme temperature conditions.

SPECIFICATIONS

Spectral range (50 % points)	305 - 2800 nm.
Sensitivity (nominal)	$7\text{ }\mu\text{V/W/m}^2$
Impedance	500 - 2000 Ω
Response time (95 %)	18 s
Temperature dependence of sensitivity	Max. 2 % ($-20\text{ }^{\circ}\text{C}$ to $+150\text{ }^{\circ}\text{C}$)
Non-stability (max change/year)	Max. 1 %
Non-linearity (0 - 2500 W/m^2)	Max. 3 %
Directional error (at 1000 W/m^2)	Max. $\pm 20\text{ W/m}^2$
Zero offsets	
(a) thermal radiation (200 W/m^2)	$\pm 15\text{ W/m}^2$
(b) temperature change (5 K/hr)	$\pm 4\text{ W/m}^2$
Tilt response	Max. 1 % when facing downwards
Maximum irradiance	4000 W/m^2
Operating temperature	$-40\text{ }^{\circ}\text{C}$ to $+150\text{ }^{\circ}\text{C}$
Environmental	Intended for continuous outdoor and/or indoor use Humidity 0 - 100 % RH
Weight	200 g
Cable length	10 m (optional 25 m)
Shock / vibration	IEC721-3-2-2m2
Classification	ISO Second Class