

**CM3 PYRANOMETER
INSTRUCTION MANUAL**

REVISION: 10/02

COPYRIGHT (c) 1999-2002 CAMPBELL SCIENTIFIC, INC.

WARRANTY AND ASSISTANCE

This equipment is warranted by CAMPBELL SCIENTIFIC (CANADA) CORP. ("CSC") to be free from defects in materials and workmanship under normal use and service for **twelve (12) months** from date of shipment unless specified otherwise. **** **Batteries are not warranted.** **** CSC's obligation under this warranty is limited to repairing or replacing (at CSC's option) defective products. The customer shall assume all costs of removing, reinstalling, and shipping defective products to CSC. CSC will return such products by surface carrier prepaid. This warranty shall not apply to any CSC products which have been subjected to modification, misuse, neglect, accidents of nature, or shipping damage. This warranty is in lieu of all other warranties, expressed or implied, including warranties of merchantability or fitness for a particular purpose. CSC is not liable for special, indirect, incidental, or consequential damages.

Products may not be returned without prior authorization. To obtain a Return Merchandise Authorization (RMA), contact CAMPBELL SCIENTIFIC (CANADA) CORP., at (780) 454-2505. An RMA number will be issued in order to facilitate Repair Personnel in identifying an instrument upon arrival. Please write this number clearly on the outside of the shipping container. Include description of symptoms and all pertinent details.

CAMPBELL SCIENTIFIC (CANADA) CORP. does not accept collect calls.

Non-warranty products returned for repair should be accompanied by a purchase order to cover repair costs.



CAMPBELL SCIENTIFIC
C A N A D A C O R P .

11564 - 149 street - edmonton - alberta - T5M 1W7
tel 780.454.2505 fax 780.454.2655

www.campbellsci.ca

CM3 Pyranometer Table of Contents

1. General Description	1
2. Specifications	1
3. Installation	2
4. Wiring	4
5. Example Programs	6
5.1 Average Solar Radiation.....	6
5.2 Total Solar Radiation.....	7
5.2.1 Output Format Considerations	8
6. Maintenance	9
7. Calibration	9

Figures

3-1. CM3 and CM3MT	3
3-2. 015 Pyranometer Mounting Arm.....	3
3-3. 025 Crossarm Stand and 019ALU Crossarm.....	4
3-4. UTKZ Leveling Fixture and Crossarm Mount and UT018 Tower Mounting Bracket and Crossarm.....	4
4-1. CM3 Wiring.....	5

Tables

5-1. Multipliers Required for Average Flux and Total Flux Density in SI and English Units	6
--	---

CM3 Pyranometer

1. General Description

This manual provides information for interfacing Kipp & Zonen's CM3 Pyranometer to a CR10(X), CR510, CR23X, CR7 or 21X datalogger.

The CM3 is shipped with an instruction manual provided by Kipp & Zonen that contains information concerning the CM3's construction, spectral sensitivity, cosine response, and a simple sensor check out procedure. Included with the sensor and manual is a calibration certificate with the sensor calibration constant and serial number. Cross check this serial number against the serial number on your CM3 to ensure that the given calibration constant corresponds to your sensor.

The CM3 pyranometer is designed for continuous outdoor use. Due to its flat spectral sensitivity from 300 to 3000 nm, it can be used in natural sunlight, under plant canopies, in green houses or buildings, and inverted to measure reflected solar radiation. Two CM3s can be used in combination with an albedometer fixture (K&Z's CAF 1) to measure albedos. The CM3 can also be used to measure most types of artificial light (Xenon lamps, Halogen lamps, etc.).

The CM3 pyranometer consists of a thermopile sensor, a housing, a dome, and a cable. The thermopile is coated with a black absorbent coating. The paint absorbs the radiation and converts it to heat. The resultant temperature difference is converted to a voltage by the copper-constantin thermopile. The thermopile is encapsulated in the housing in such a way that it has a field of view of 180 degrees and the angular characteristics needed to fulfill the cosine response requirements.

2. Specifications

The CM3 is an ISO Second Class pyranometer. While the worst case accuracy for daily sums given by Kipp & Zonen is $\pm 10\%$, the typical accuracy is $\pm 5\%$. Tests at Campbell Scientific on one CM3 indicated an accuracy of $\pm 2\%$ when compared to a recently calibrated Eppley PSP.

ISO SPECIFICATIONS:

Response Time 95%:	18 seconds
Zero offset due to 200 W/m ² thermal radiation:	< 15 Wm ⁻²
Zero offset due to temperature change of 5°K / hr:	< ± 4 Wm ⁻²
Non stability (% change/year):	< $\pm 1\%$
Non linearity (at 1000 W/m ²):	< $\pm 2.5\%$
Directional error (at 1000 W/m ²):	< ± 25 Wm ⁻²
Temperature Dependence of	

sensitivity: $\pm 6\%$ (-10 to +40°C)
Tilt response ($\pm 80^\circ$) (at 1000 W/m²): $< \pm 2\%$

OTHER SPECIFICATIONS

Expected accuracy for daily sums: $\pm 10\%$
Spectral range (50% points, nm): 305-2800 nm
Sensitivity: 10 - 35 $\mu\text{V}/\text{Wm}^{-2}$
Expected signal output in atmospheric application: 0 - 50 mV
Impedance: 79 - 200 (Ω)
Operating Temperature: -40 to +80°C
Max. irradiance: 2000 Wm^{-2}
Detector: Copper-constantin multi junction thermopile
Cable length: 15 feet (5 m)
Level accuracy: 1 degree

DIMENSIONS / SHIPPING DIMENSIONS

CM3: 3x3x3 in / 6x6x6 in
CM3MT: 1x5x5 in / 6x6x6 in

WEIGHT/SHIPPING WEIGHT

CM3: 0.8 lbs / 3 lbs
CM3MT: 0.6 lbs / 3 lbs

3. Installation

The CM3 should be mounted such that it is never shaded by the tripod/tower or other sensors.

To ensure accurate measurements, the CM3 should be mounted using the CM3MT base/leveling fixture or equivalent. The CM3MT incorporates a bubble level and three adjustment screws. Mount the CM3 Pyranometer to the CM3MT mount using the two long screws provided. The screws are slightly shorter than ideal but should provide adequate holding strength.

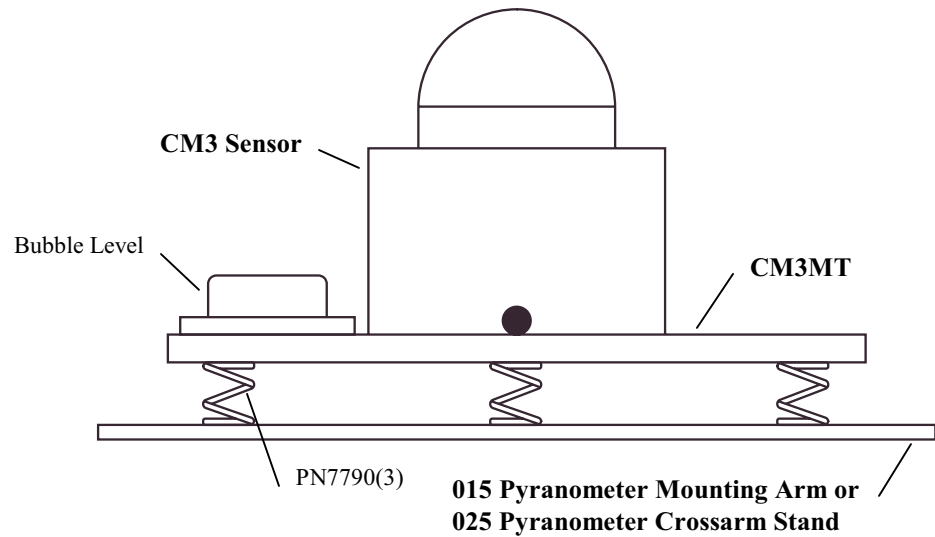

FIGURE 3-1. CM3 and CM3MT

Install the CM3MT Mount on either the 025 Pyranometer Cross Arm Stand, the 015 Pyranometer Mounting Arm, or the UTKZ (not yet available, please call) before mounting them to the tower or tripod. This is done by first threading the screws through the springs and just barely through the mounting plate. This helps remove any paint that might have gotten into the threaded holes. Second, remove two of the screws/springs, slide the CM3MT Mount onto the remaining screw by slightly compressing the spring. Slide the remaining two springs between the CM3MT and the 015 or 025 mount and install the remaining two screws. Tighten the screws until all three springs have been compressed about 1/8 inch.

Once the pyranometer mount has been installed on the tripod or tower, tighten the appropriate screws until the bubble indicates the sensor is level.

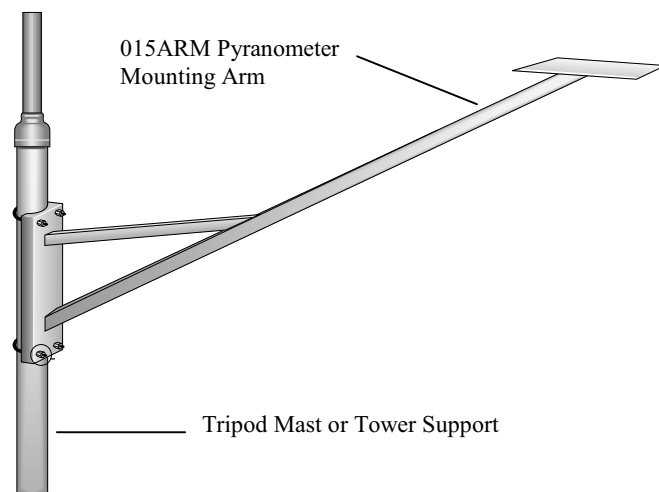

FIGURE 3-2. 015 Pyranometer Mounting Arm

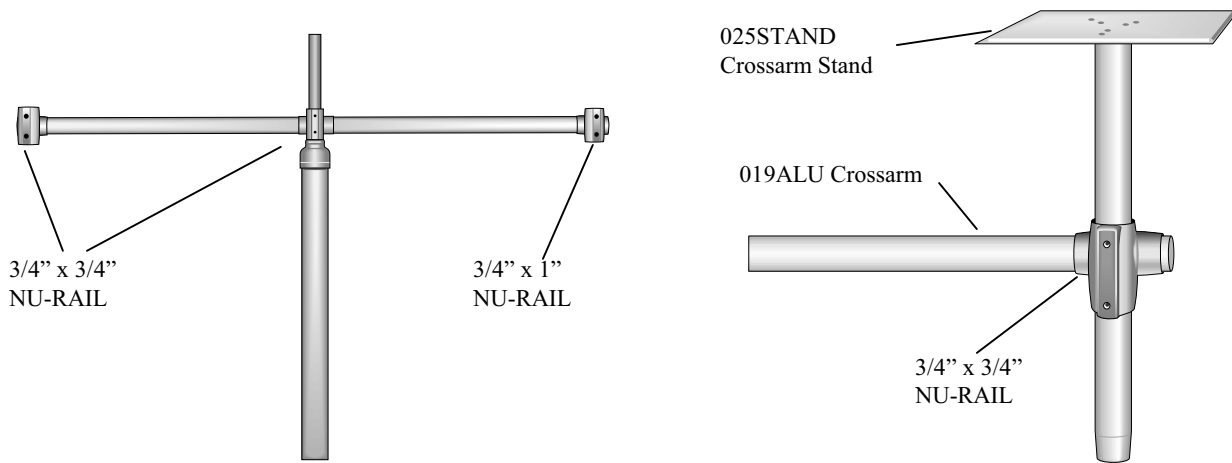

FIGURE 3-3. 025 Crossarm Stand and 019ALU Crossarm

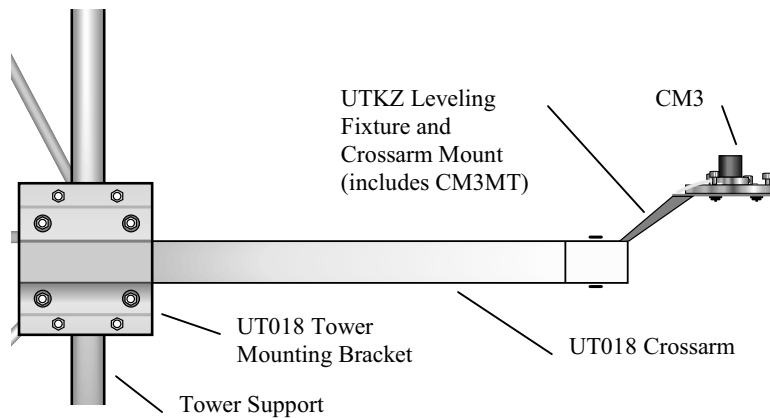

FIGURE 3-4. UTKZ Leveling Fixture and Crossarm Mount and UT018 Tower Mounting Bracket and Crossarm

4. Wiring

Use Differential Voltage measurement instruction 2 to measure the CM3. The CM3 wiring diagram is shown in Figure 4-1.

The red lead is connected to the high side (H) of any differential channel. The blue lead is connected to the corresponding low (L) side of the differential channel. On a CR10(X) or CR510, the white lead is connected to an analog ground (AG) and the clear to ground (G). On the CR23X, 21X or CR7 both the white and clear leads are connected to ground (⏏).

While a differential measurement is better and preferred, the CM3 can be measured on a single-ended channel using Instruction 1 if the power induced voltages discussed in the following paragraph are prevented.

If a 21X is used to measure the CM3 and it powers a 12 VDC sensor or 12 VDC radio, the current drawn off the 12 VDC supply may cause a difference in

ground potential between the 21X ground terminals and the reference ground point in the datalogger. This ground potential results in an offset on single ended measurements. This offset can be as large as ± 60 mV. Thus, single ended measurements should be avoided. The offset does not, however, affect differential measurements. While the 21X is the logger most susceptible to this condition, the other dataloggers can be affected if the amount of power is too large or the power return line is connected to analog ground (AG).

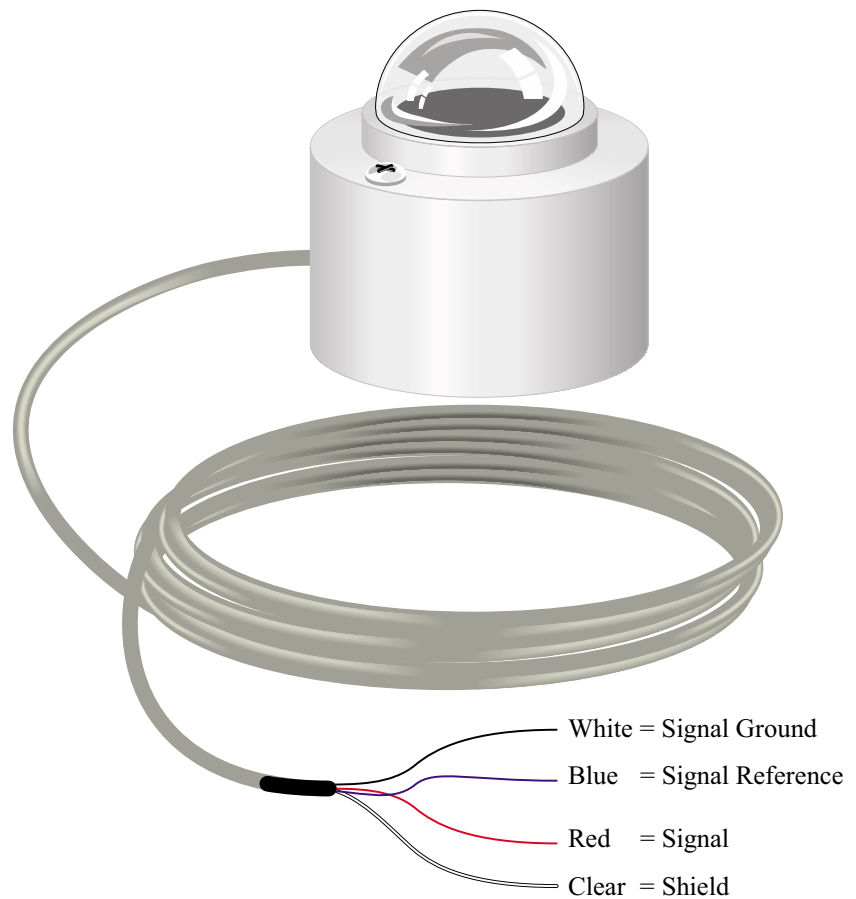

FIGURE 4-1. CM3 Wiring

<u>Color</u>	<u>Function</u>	<u>CR10(X), CR510</u>	<u>21X/CR7</u>	<u>CR23X</u>
Red	Signal	Differential Channel - H	Differential Channel - H	Differential Channel - H
Blue	Signal Reference	Differential Channel - L	Differential Channel - L	Differential Channel - L
White	Signal Ground	AG	≡	≡
Clear	Shield	G	≡	≡

5. Example Programs

Solar radiation can be reported as an average flux density ($W\ m^{-2}$) or daily total flux density ($MJ\ m^{-2}$). The appropriate multipliers are listed in Table 5-1. Programming examples are given for both average and daily total solar radiation.

The output from the CM3 varies from $10^{-35}\ V / W\ m^{-2}$. Given a maximum solar radiation of $1500\ W\ m^{-2}$, the maximum sensor output voltage will be $15 - 52.5\ mV$. Example:

$$(21.87 \times 10^{-6}\ V\ W^{-1}\ m^2) * (1500\ W\ m^{-2}) = 0.03281\ V\ \text{or}\ 32.81\ mV$$

TABLE 5-1. Multipliers Required for Average Flux and Total Flux Density in SI and English Units		
UNITS	MULTIPLIERS	
$W\ m^{-2}$	$\frac{1}{C * 10^3}$	(average)
$MJ\ m^{-2}$	$\frac{t}{C * 10^9}$	(total)
$kJ\ m^{-2}$	$\frac{t}{C * 10^6}$	(total)
$cal\ cm^{-2}\ min^{-1}$	$\frac{1.4333}{C * 10^6}$	(average)
$cal\ cm^{-2}$	$\frac{t * 0.02389}{C * 10^6}$	(total)
C=CM3 calibration: eg. $21.87 \times 10^{-6}\ V / W\ m^{-2}$		
t = datalogger execution interval in seconds		

5.1 Average Solar Radiation

Example 1 shows the program instructions used by a CR10X to measure the signal from the CM3. A sixty-minute average is calculated and stored in final storage.

Example 1

```

;{CR10X}
;
;*Table 1 Program
  01: 10      Execution Interval (seconds)

1: Volt (Diff) (P2)
  1: 1      Reps
  2: 24     250 mV 60 Hz Rejection Range
  3: 1      DIFF Channel
  4: 1      Loc [ W_m2  ]
  5: 45.725 Mult ;multiplier = (1 / 0.02187 mV / W/m2)
  6: 0.0    Offset

;Set negative values to zero.
;
2: If (X<=>F) (P89)
  1: 1      X Loc [ W_m2  ]
  2: 4      <
  3: 0      F
  4: 30     Then Do

3: Z=F x 10^n (P30)
  1: 0.0    F
  2: 00     n, Exponent of 10
  3: 1      Z Loc [ W_m2  ]

4: End (P95)

5: If time is (P92)
  1: 0      Minutes (Seconds --) into a
  2: 60     Interval (same units as above)
  3: 10     Set Output Flag High (Flag 0)

6: Real Time (P77)
  1: 1220   Year,Day,Hour/Minute (midnight = 2400)

7: Average (P71)
  1: 1      Reps
  2: 1      Loc [ W_m2  ]

;*Table 2 Program
  02: 0.0000 Execution Interval (seconds)

;*Table 3 Subroutines

End Program

```

5.2 Total Solar Radiation

In Example 2 a CR10X is used to record daily total flux density. This total flux density is in $\text{MJ m}^{-2} \text{ day}^{-1}$ to avoid the need for high resolution discussed in 5.2.1. Negative values are set to zero before they are added to the running total.

5.2.1 Output Format Considerations

If the solar radiation is totalized in units of kJ m^{-2} , there is a possibility of over-ranging the output limits. The largest number that the datalogger can output to final storage is 6999 in low resolution and 99999 in high resolution (Instruction 78, Set Resolution).

Assume that the daily total flux density is desired in kJ m^{-2} . Assume an irradiance of 0.5 kW m^{-2} , the maximum low-resolution output limit will be exceeded in just under four hours. This value was found by taking the maximum flux density the datalogger can record in low resolution and dividing by the total hourly flux density.

$$3.9\text{hr} = \frac{6999\text{kJm}^{-2}}{(0.5\text{kJm}^{-2}\text{s}^{-1})(3600\text{shr}^{-1})}$$

To circumvent this limitation, record an average flux (see Example 1). Then, during post processing, multiply the average flux by the number of seconds in the output interval to arrive at an output interval flux density. Sum the output interval totals over a day to find a daily total flux density.

Another alternative is to record total flux using the high-resolution format (Instruction 78, see Datalogger manual for details). The disadvantage of the high-resolution format is that it requires four bytes of memory per data point, consuming twice as much memory as low resolution. (Given the larger amount of memory in today's dataloggers, this may not matter.)

Example 2

```

;{CR10X}
;
*Table 1 Program
 01: 10      Execution Interval (seconds)

1: Volt (Diff) (P2)
  1: 1      Reps
  2: 24     250 mV 60 Hz Rejection Range
  3: 1      DIFF Channel
  4: 1      Loc [ MJ_m2____ ]
  5: 0.45725  Mult ;multiplier = [10s / (21870 mV / MJ/m2)]      Step 1 of 2
  6: 0.0     Offset

2: Z=X*F (P37)
  1: 1      X Loc [ MJ_m2____ ]
  2: 0.001  F      Step 2 of 2
  3: 1      Z Loc [ MJ_m2____ ]

;Set negative values to zero.
;
3: If (X<=>F) (P89)
  1: 1      X Loc [ MJ_m2____ ]
  2: 4      <
  3: 0      F
  4: 30     Then Do
    
```

```

4: Z=F x 10^n (P30)
  1: 0.0      F
  2: 00      n, Exponent of 10
  3: 1      Z Loc [ MJ_m2_____ ]

5: End (P95)

6: If time is (P92)
  1: 0      Minutes (Seconds --) into a
  2: 60      Interval (same units as above)
  3: 10      Set Output Flag High (Flag 0)

7: Real Time (P77)
  1: 1220    Year,Day,Hour/Minute (midnight = 2400)

8: Totalize (P72)
  1: 1      Reps
  2: 1      Loc [ MJ_m2_____ ]

*Table 2 Program
  02: 0.0000 Execution Interval (seconds)

*Table 3 Subroutines

End Program

```

6. Maintenance

On a monthly basis the level of the pyranometer should be checked. Any dust or debris on the sensor window should be removed. The debris can be removed using water (de-ionized or distilled) or alcohol.

7. Calibration

Recalibration is suggested every two years. Calibrations can be done in one of two ways.

One method is to calibrate the sensor in the field by placing a “transfer standard” (a sensor that has been calibrated against a “secondary standard”) next to the sensor being calibrated. Preferably daily totals of several days should be compared. The calibration factor could be corrected if results differ by more than six percent.

Another method would be to send the sensor to a facility that has a “secondary standard”. Contact Kipp & Zonen (www.kippzonen.com) for the nearest calibration facility, or send it to Campbell Scientific and they will have it recalibrated.

