

INSTRUCTION MANUAL

CM 21

PYRANOMETER



CAMPBELLSCIENTIFIC
CANADA CORP.

11564 - 149 street - edmonton - alberta - T5M 1W7
tel 780.454.2505 fax 780.454.2655
www.campbellsci.ca

WARRANTY AND ASSISTANCE

This equipment is warranted by CAMPBELL SCIENTIFIC (CANADA) CORP. ("CSC") to be free from defects in materials and workmanship under normal use and service for **twelve (12) months** from date of shipment unless specified otherwise. ***** **Batteries are not warranted.** ***** CSC's obligation under this warranty is limited to repairing or replacing (at CSC's option) defective products. The customer shall assume all costs of removing, reinstalling, and shipping defective products to CSC. CSC will return such products by surface carrier prepaid. This warranty shall not apply to any CSC products which have been subjected to modification, misuse, neglect, accidents of nature, or shipping damage. This warranty is in lieu of all other warranties, expressed or implied, including warranties of merchantability or fitness for a particular purpose. CSC is not liable for special, indirect, incidental, or consequential damages.

Products may not be returned without prior authorization. To obtain a Return Merchandise Authorization (RMA), contact CAMPBELL SCIENTIFIC (CANADA) CORP., at (780) 454-2505. An RMA number will be issued in order to facilitate Repair Personnel in identifying an instrument upon arrival. Please write this number clearly on the outside of the shipping container. Include description of symptoms and all pertinent details.

CAMPBELL SCIENTIFIC (CANADA) CORP. does not accept collect calls.

Non-warranty products returned for repair should be accompanied by a purchase order to cover repair costs.



CAMPBELL SCIENTIFIC
C A N A D A C O R P .

11564 - 149 street - edmonton - alberta - T5M 1W7
tel 780.454.2505 fax 780.454.2655

www.campbellsci.ca

IMPORTANT USER INFORMATION

**Reading this entire manual is recommended for full
understanding of the use of this product.**



The exclamation mark within an equilateral triangle is intended to alert the user to the presence of important operating and maintenance instructions in the literature accompanying the instrument.

Should you have any comments on this manual we will be pleased to receive them at:

Kipp & Zonen B.V.
Röntgenweg 1 2624 BD Delft
P.O. Box 507 2600 AM Delft
Holland
Phone +31 (0)15 2698000
Fax +31 (0)15 2620351
Email info.holland@kippzonen.com

Kipp & Zonen reserve the right to make changes to the specifications without prior notice.

WARRANTY AND LIABILITY

Kipp & Zonen guarantees that the product delivered has been thoroughly tested to ensure that it meets its published specifications. The warranty included in the conditions of delivery is valid only if the product has been installed and used according to the instructions supplied by Kipp & Zonen.

Kipp & Zonen shall in no event be liable for incidental or consequential damages, including without limitation, lost profits, loss of income, loss of business opportunities, loss of use and other related exposures, however caused, arising from the faulty and incorrect use of the product. User made modifications can affect the validity of the CE declaration.

COPYRIGHT® 2001 KIPP & ZONEN

All rights reserved. No part of this publication may be reproduced, stored in a retrieval system or transmitted in any form or by any means, without permission in written form from the company.



DECLARATION OF CONFORMITY

According to EC guideline 89/336/EEC 73/23/EEC

We **Kipp & Zonen B.V.**
Röntgenweg 1
2624 BD Delft

Declare under our sole responsibility that the product

Type: **CM 21**
Name: **Pyranometer**

To which this declaration relates is in conformity with the following standards

Immissions EN 50082-1 Group standard

Emissions EN 50081-1 Group standard
EN 55022

Safety standard IEC 1010-1

Following the provisions of the directive



B.A.A Dieterink
President
KIPP & ZONEN B.V.

TABLE OF CONTENTS

IMPORTANT USER INFORMATION	3
DECLARATION OF CONFORMITY	4
TABLE OF CONTENTS	5
1. GENERAL INFORMATION	7
1.1 INTRODUCTION	7
1.2 PHYSICAL PRINCIPLES OF THE PYRANOMETER	8
1.2.1 Zero offsets	9
1.2.3 Directional error	10
1.2.4 Low temperature dependency of sensitivity	11
2 TECHNICAL DATA	13
2.1 SPECIFICATIONS OF CM 21 PYRANOMETER ACCORDING TO ISO 9060 LISTING	13
2.2 ACCURACY	16
3 INSTALLATION	19
3.1 DELIVERY	19
3.2 MECHANICAL INSTALLATION	20
3.2.1 Installation for measurement of global radiation	20
3.2.2 Installation for measurement of solar radiation on inclined surfaces	23
3.2.3 Installation for measurement of reflected global radiation	24
3.2.4 Installation for measurement of diffuse radiation	25
3.2.5 Installation for measurement of albedo	25
3.2.6 Underwater use	26
3.3 ELECTRICAL CONNECTION	27
4 OPERATION	31
5 MAINTENANCE	33

6 CALIBRATION	35
6.1 INITIAL CALIBRATION	35
6.2 RECALIBRATION	35
6.3 CALIBRATION PROCEDURE AT KIPP & ZONEN	37
6.3.1 The facility	37
6.3.2 Procedure	37
6.3.3 Calculation	38
6.3.4 Zero offset	38
6.3.5 Traceability to World Radiometric Reference	39
7 FREQUENTLY ASKED QUESTIONS (FAQ's)	41
8 TROUBLE SHOOTING	43
9 PART NUMBERS / SPARE PARTS / OPTIONS	45
APPENDIX I CLASSIFICATION ACCORDING TO WMO GUIDE 1996	47
APPENDIX II RADIOMETRIC LEVELING	49
APPENDIX III LIST OF WORLD AND REGIONAL RADIATION CENTRES	51
APPENDIX IV PYRANOMETER MEASUREMENT REPORT	53
APPENDIX V THERMISTOR SPECIFICATIONS	55
APPENDIX VI PT-100 SPECIFICATIONS	57
APPENDIX VII RECALIBRATION SERVICE	59

1. GENERAL INFORMATION

1.1 INTRODUCTION

The CM 21 pyranometer is designed for measuring the irradiance (radiant-flux, Watt/m^2) on a plane surface, which results from the direct solar radiation and from the diffuse radiation incident from the hemisphere above.

CM 21 is a high precision pyranometer with strictly selected domes. Because of the high optical quality of these domes the directional error is reduced to less than 10 W/m^2 .

The special features of the CM 21 are:

- High sensitivity, which could result in lower specifications for the data acquisition system.
- Low impedance, which reduces sensitivity for interference and noise.
- Low temperature response, which is an advantage when working under extreme climatological conditions.
- Low non-linearity.

Like the CM 11 pyranometer, the CM 21 complies with the specifications for the best of three classes, "High quality", as defined in the 'Guide to meteorological Instruments and Methods of Observation', sixth edition, 1996, of the World Meteorological

Organisation (*WMO) - Geneva - Switzerland. Some specifications of the CM 21 are twice as good as required.

For measuring the diffuse component of solar radiation only, the direct solar component can be shielded semi-automatically from the pyranometer by the Kipp & Zonen shadow ring CM 121. Fully automatic shielding can be done with the 2AP tracker with shading device.

* The WMO classification is adapted from the international standard ISO 9060 (1990). Herein "high quality" class is referred to as "secondary standard".

1.2 PHYSICAL PRINCIPLES OF THE PYRANOMETER

The pyranometer CM 21 is provided with a thermal detector. This type of detector responds to the total power absorbed and theoretically it is non-selective as to the spectral distribution of the radiation. This implies that the naked thermal detector is also sensitive to long wave infrared radiation (thermal radiation $\lambda > 3000$ nm) from the environment. (e.g. the inner dome)

The radiant energy is absorbed by a black painted disk. The heat generated flows through a thermal resistance to the heatsink (the pyranometer body). The temperature difference across the thermal resistance of the detector is converted into a voltage.

The rise of temperature is easily affected by wind, rain and thermal radiation losses to the environment ('cold' sky). Therefore the detector is shielded by two glass domes. These domes allow equal transmittance of the direct solar component for every position of the sun on the celestial sphere. A dessicator in the body prevents dew on the inner side of the domes, which can cool down considerably on clear windless nights.

When the pyranometer is illuminated a temperature difference arise between the centre and the border of the black absorber. Natural convection inside the inner dome due to this temperature difference is small and therefore tilting the CM 21 causes no significant change of sensitivity.

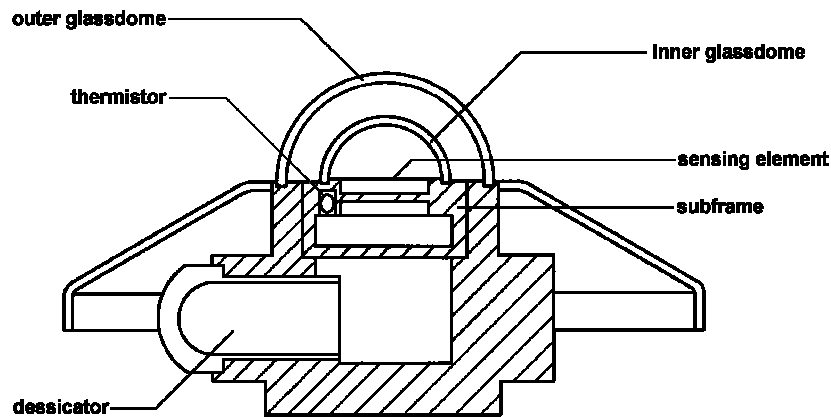

Figure 1 Construction details of a CM 21 pyranometer

1.2.1 Zero offsets

Zero offset type B

Heat flows in the sensing element e.g. due to rising or falling body temperature normally cause a spurious voltage., called zero offset. To compensate for this offset, a second non-illuminated element is installed, in which the same heat flow will arise. By anti-series arrangement of both elements the spurious voltage is cancelled out greatly. The white plastic screen reduces the body temperature variations due to solar radiation and (cold) rain showers.

Zero offset type A

This zero offset is present when there is a temperature difference between the inner dome and the cold junctions of the sensor.

In practice a zero offset will be present when there is a clear sky. Because of the low effective sky temperature ($<0^{\circ}\text{C}$) the earth surface emits roughly 100 W/m^2 longwave infrared radiation upwards. The outer glass dome of a pyranometer also has this emission and is cooling down several degrees below air temperature (the emissivity of glass for the particular wavelength

region is nearly 1). The emitted heat is extracted from the body (by conduction in the dome), from the air (by wind) and from the inner dome (through infrared radiation). The inner dome is cooling down too and will extract heat from the body by conduction and from the sensor by the net infrared radiation again. The latter heat flow is opposite to the heat flow from absorbed solar radiation and causes the well known zero depression at night. This negative zero offset is also present on a clear day, however, hidden in the solar radiation signal. Because the temperature difference between the body and the (clear) sky is higher during day time, the zero-offset will also be higher.

During indoor measurements with a solar simulator, the inner dome can become warmer than the pyranometer body due to net thermal radiation from the lamp housing. A positive zero offset type A is the result.

Zero offset type A can be checked by placing a light and IR reflecting cap over the pyranometer. The response to solar radiation will decay with a time constant ($1/e$) of 5 s, but the dome temperature will go to equilibrium with a time constant of several minutes. So after half a minute the remaining signal represents mainly zero offset type A. Good ventilation of domes and body is the solution to reducing zero offsets even further. Kipp & Zonen advises the CV 2 for optimal ventilation and suppression of zero offset type A.

1.2.3 Directional error

The directional error is an individual feature and depends on imperfections of the glass domes, angular reflection properties of the black paint and tolerances on the pyranometer construction. The directional error is a combination of the error in zenith and azimuth directions.

This Kipp & Zonen CM 21 pyranometer is manufactured with great care. Each pyranometer is constructed with selected glass domes. The glass domes are matched and positioned with high precision.

Before leaving the factory, the cosine response of each CM 21 is measured. At four zenith angles the cosine response versus two azimuth's is determined.

These values (40° and 70°) are stated on the calibration certificate, expressed as percentage deviation from the ideal proportionality and as absolute values (see appendix IV).

1.2.4 Low temperature dependency of sensitivity

The sensitivity is correlated to the temperature as a consequence of physical material properties of the sensor. For a given heat flow, the sensitivity of the pyranometer is a function of the thermal conductivity of the sensor and of the thermo-electric power of the thermocouple material. Both physical parameters show temperature dependency.

Due to the sensor construction and applied thermistor compensation circuit the temperature response is suppressed to a minimum between -20°C and $+50^{\circ}\text{C}$.

During factory manufacturing the sensitivity of each CM 21 pyranometer is measured and compensated to provide the temperature dependency specifications.

The temperature dependency is supplied with each instrument, measured in 8 steps of 10°C , from $+50^{\circ}\text{C}$ to -20°C .

2 TECHNICAL DATA**2.1 SPECIFICATIONS OF CM 21 PYRANOMETER ACCORDING TO
ISO 9060 LISTING**

Spectral range:	305-2800 nm (50% points) 335-2200 nm (95% points)
Sensitivity:	between 7 and 17 $\mu\text{V}/\text{Wm}^{-2}$
Impedance:	40 -100 Ohm
Response time:	5 s (95% response) 1.6 s (63% response)?
Non-linearity:	$< \pm 0.2\%$ ($< 1000 \text{ W}/\text{m}^2$)
Spectral selectivity	$\pm 2\%$
Temperature dependence of sensitivity:	$< \pm 1\%$ (-20°C to $+50^\circ\text{C}$)
Directional error:	$< \pm 10 \text{ W}/\text{m}^2$ (beam $1000 \text{ W}/\text{m}^2$)
Tilt error	$< \pm 0.2\%$ (beam $1000 \text{ W}/\text{m}^2$)
Zero-offset due to FIR (Ventilated)	$< 7 \text{ W}/\text{m}^2$ at $200 \text{ W}/\text{m}^2$ net thermal radiation
Zero-offset due to temp. changes	$< 2 \text{ W}/\text{m}^2$ at 5 K/h temp. change
Operating temperature	-40°C to $+80^\circ\text{C}$
Viewing angle:	$2 \pi \text{ sr}$

Max. irradiance: 0 - 4000 W/m²

Non-stability: < ± 0.5% sensitivity change per year

The specified directional response includes (as relative errors) :

Cosine response: max. ± 2% deviation from ideal at 60° solar zenith angle in any azimuth direction.
max. ± 6% deviation from ideal at 80° solar zenith angle in any azimuth direction.

Construction

Receiver paint: Carbon black
Quartz domes: Schott K5 optical glass 2 mm thick, 30 mm and 50 mm outer diameter
Desiccant: Silica gel
Spirit level: Sensitivity 0.1 degree (bubble half out of the ring)
Integral with base of instrument.
Detector surface and base are coplanar within 0.1°
Materials: Anodised aluminium case
Aluminium levelling screws
Stainless steel screws etc.
White plastic screen, ASA
Drying cartridge, PMMA
Weight: 930 g
Cable length: 10 m
Dimensions: W x H 150 x 95 mm. See figure 2

CM 21 specifications compared against the WMO 1996 qualification classes are shown in appendix I.

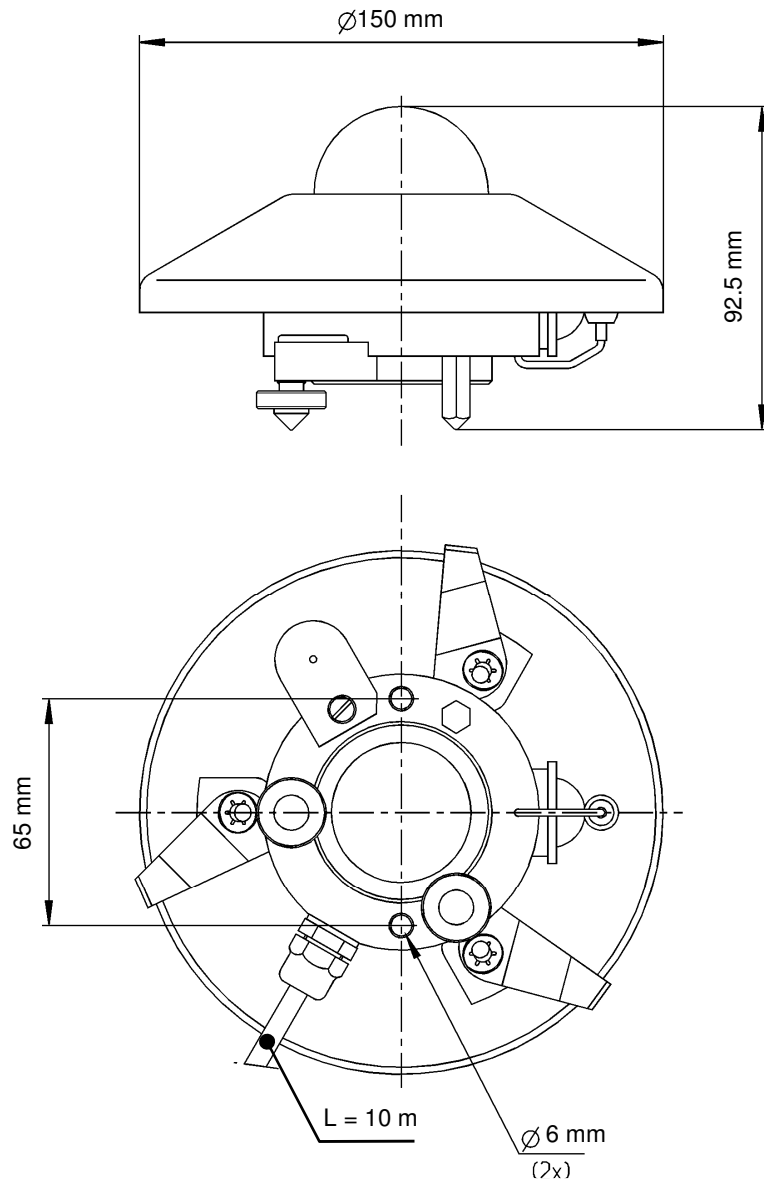

Figure 2 CM 21 Pyranometer outline dimensions in mm.

2.2 ACCURACY

As listed in 2.1 the sensitivity is cross-correlated to a number of parameters, such as temperature, level of irradiance, angle of incidence, etc.

Normally, the supplied sensitivity figure is used to calculate the irradiances. If the conditions differ from calibration conditions, errors in the calculated irradiances must be expected.

For a secondary standard instrument the WMO expects maximum errors in the hourly radiation totals of 3 %. In the daily total an error of 2 % is expected, because some response variations cancel out each other if the integration period is long.

Kipp & Zonen expects max errors of 2 % for hourly totals and 2 % for daily totals.

These remaining errors can be reduced further if the actual sensitivity of the pyranometer is used by the conversion of voltage to irradiance. The actual sensitivity can be calculated when it is a well known function of simply measured parameters (sometimes called transfer function or sensitivity function).

This is especially convenient in connection with a programmable data acquisition system.

For the CM 21 the effect of each parameter on the sensitivity can be shown separately, because the parameters show less interaction.

The *non-linearity* error, the sensitivity variation with irradiance, is the same for any CM 21 and negligible.

The temperature dependence of the sensitivity is an individual function. For a given CM 21 the curve is somewhere in the region between the curved lines in figure 3.

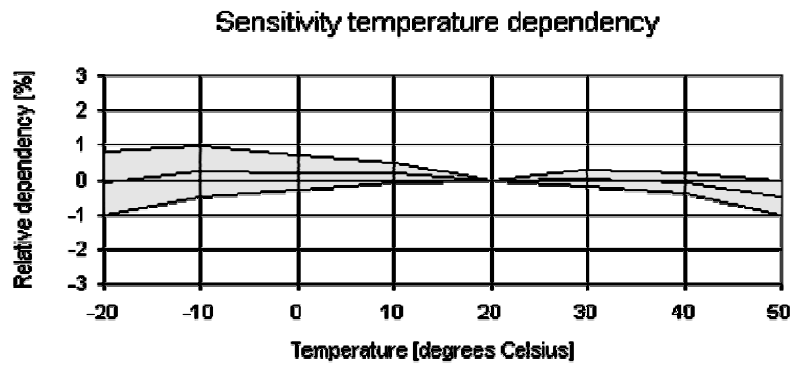

Figure 3 The curve of relative sensitivity variation with instrument temperature of a CM 21 pyranometer is in the shaded region.

The *directional error* is the summation of the azimuth and zenith error and is commonly given in W/m^2 . Figure 4 shows the maximum relative zenith error in any azimuth direction for the CM 21.

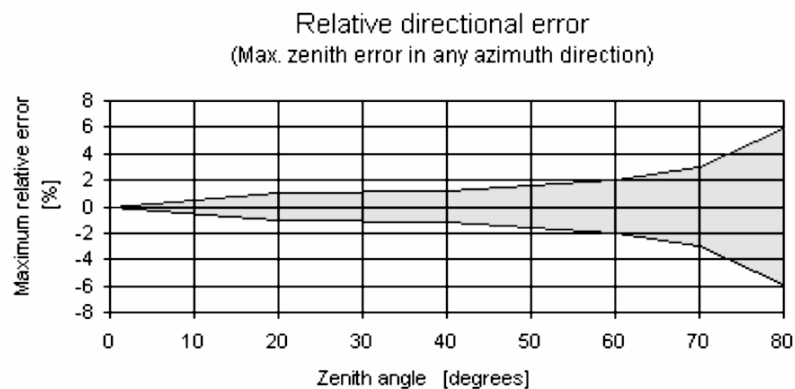

Figure 4 Relative directional error is van CM 21.

Spectral selectivity is the product of spectral absorptance of the black coating and spectral transmittance of the glass domes (see fig. 5 and 6). Shifts in the solar spectrum, due to changes from clear to overcast sky, are mainly in the mid of the spectral range. No significant spectral selectivity errors have to be expected. E.g. at a sun's elevation of 30° (air mass 2) only 1 % of the solar radiation has wavelengths below 335 nm and only 1 % has wavelengths above 2200 nm.

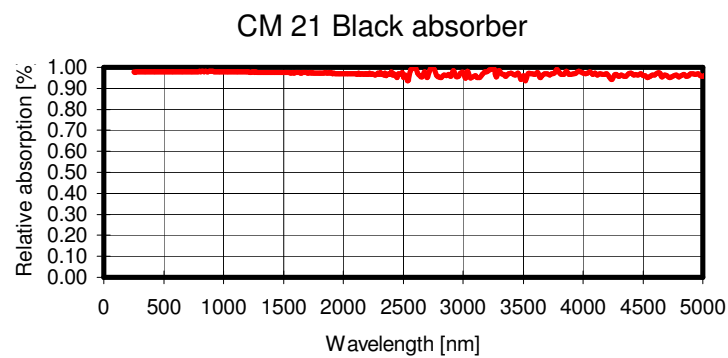

Figure 5 CM 21 Black absorbers relative absorption [%]

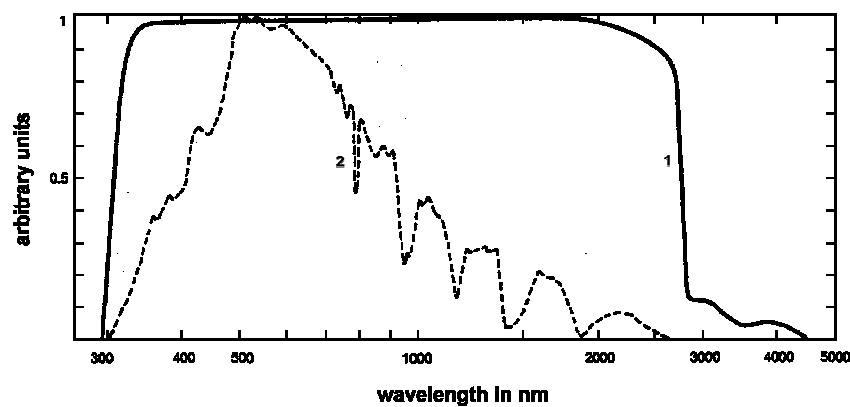

Figure 6 1. Relative transmittance of two pyranometer domes.
2. Spectral distribution of solar radiation at sea level. Sun at zenith (airmass 1).

3 INSTALLATION

Reading the installation instructions before installation is recommended.

3.1 DELIVERY

Check the contents of the shipment for completeness (see below) and note whether any damage has occurred during transport. If there is damage, a claim should be filed with the carrier immediately. In this case, and also if the contents are incomplete, your dealer should be notified in order to facilitate the repair or replacement of the instrument.

The CM 21 pyranometer delivery will include the following items:

1. CM 21 pyranometer
2. White sun screen
3. 2 x Mounting bolts + nuts + washers (M5 x 80)
4. 2 x nylon insulators
5. Calibration certificate
6. Temperature dependency data

Unpacking

Keep the original packaging for later shipments!

Although all sensors are weatherproof and suitable for rough ambient conditions, they do partially consist of delicate mechanical parts. For this type of equipment, keep the original shipment packaging to safely transport the equipment to the measurement site.

3.2 MECHANICAL INSTALLATION

The mechanical installation of the pyranometer depends upon the measuring purpose. Different measuring methods will be explained in the next paragraphs.

3.2.1 Installation for measurement of global radiation

The following steps must be carefully taken for an optimal performance of the instrument:

1. Location

Ideally the site for the pyranometer should be free from any obstructions above the plane of the sensing element, and at the same time the pyranometer should be readily accessible to clean the outer dome and inspect the dessicator. If this is not possible, the site should be chosen in such a way that any obstruction over the azimuth range between earliest sunrise and latest sunset should have an elevation not exceeding 5° (The apparent sun diameter is 0.5°). This is important for an accurate measurement of the direct solar radiation. The diffuse (solar) radiation is less influenced by obstructions near the horizon. For instance, an obstruction with an elevation of 5° over the whole azimuth range of 360° decreases the downward diffuse solar radiation by only 0.8%.

It is evident that the pyranometer should be located in such a way that a shadow will not be cast on it at any time (for example, by masts or exhaust pipes). Note that hot (over 200 degrees centigrade) exhausted gas will produce radiation in the spectral range of the CM 21 Pyranometer.

The pyranometer should be distant from light-coloured walls or other objects likely to reflect sunlight onto it.

In principle no special orientation of the instrument is required.

The World Meteorological Organisation recommends that the emerging leads are pointed to the nearest pole, to minimise heating of the electrical connections.

However, if a polar diagram of the combined azimuth and cosine response is available, the pyranometer may be orientated so that the solar path lies in the low error region.

2. Mounting

The CM 21 pyranometer is provided with two holes for 5 mm bolts. Two stainless steel bolts and two nylon rings are provided. The pyranometer should first be secured lightly with the bolts to a mounting stand or platform (Shown in figure 7).

Note: After reinstallation and recalibration the nylon insulators must be replaced with new ones to prevent corrosion.

The mounting stand temperature can vary over a wider range than the air temperature. Temperature fluctuations of the pyranometer body can produce offset signals. It is recommended to isolate the pyranometer thermally from the mounting stand, e.g. by placing it on its levelling screws. But keep an electrical contact with earth to conduct away currents in the cable shield induced by lightning.

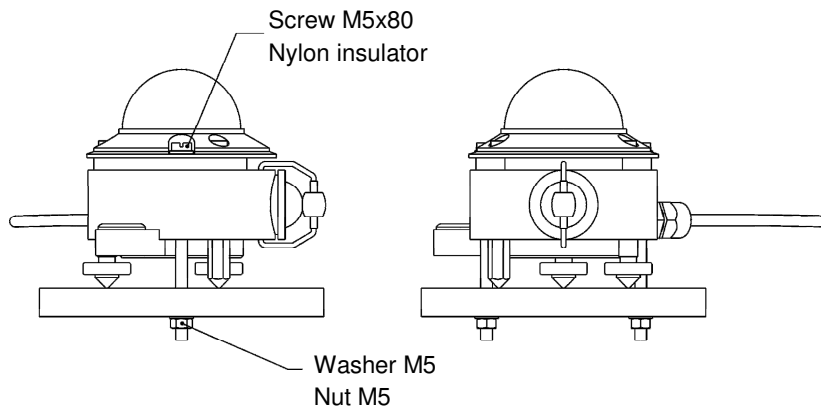

Figure 7 *Mounting the pyranometer.*

3. Levelling

Accurate measurement of the global radiation requires proper levelling of the thermopile surface. Level the instrument by turning the levelling screws to bring the bubble of the spirit level within the marked ring.

For easy levelling first use the screw nearest to the spirit level.

When the CM 21 is placed horizontally using the spirit level, or when it is mounted with its base on a horizontal plane, the thermopile is horizontal within 0.05°. This causes an extra azimuthal variation of + or - 0.5% at a solar elevation of 10°. By radiometrically levelling, the pyranometer can be placed more accurately horizontal (See Appendix II).

Finally, the pyranometer should be secured tight with the two stainless steel bolts. Ensure that the pyranometer maintains the correct levelled position!

3.2.2 Installation for measurement of solar radiation on inclined surfaces

See also 'installation for measurement of global radiation'.

It is advised to pre-adjust the levelling screws on a horizontal surface for easy orientation of the instrument parallel to the inclined surface. Because the temperature of the mounting stand is expected to rise considerably (more than 10°C above air temperature), the body must be thermally isolated by the levelling screws from the stand. This will promote a thermal equilibrium between domes and body and decrease zero offset signals.

The CM 21 pyranometer shows no significant tilt effect up to irradiances of 1000 W/m².

3.2.3 Installation for measurement of reflected global radiation

In the inverted position the pyranometer measures reflected global radiation. According to the WMO the height should be 1-2 m above a surface covered by short cut grass.

The mounting device should not interfere too much with the field of view of the instrument. A construction as in fig. 8 is suitable.

The upper screen prevents excessive heating of the pyranometer body by the solar radiation and, if large enough, it keeps the lower screen free of precipitation. The lower screen prevents direct illumination of the domes by the sun at sunrise and sunset.

Offset signals generated in the pyranometer by thermal effects (see paragraph 1.2.1) are a factor of 5 more significant in the measurement of the reflected radiation due to the lower irradiance level.

The mast in the construction of figure 8 intercepts a fraction $D / 2 \pi sr.$ of the radiation coming from the ground.

In the most unfavourable situation (sun at zenith) the pyranometer shadow decreases the signal by a factor R^2 / H^2 .

A rule of thumb is:
A black shadow with radius = $0.1 H$ on the field below decreases the signal 1%.
Secondly 99% of the signal comes from an area with radius $10 H$.

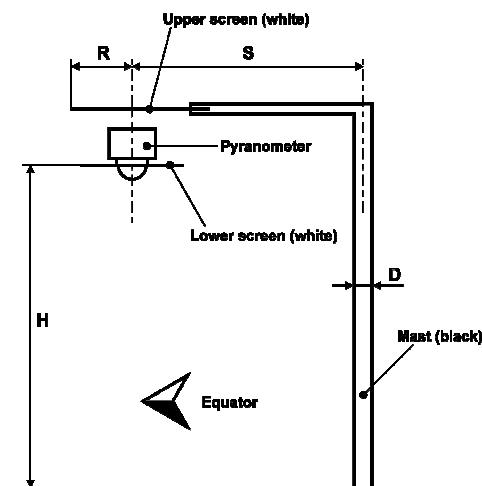

Figure 8 Arrangement to measure reflected global radiation

3.2.4 Installation for measurement of diffuse radiation

For measuring sky radiation, the direct solar radiation is best intercepted by a small disk or sphere. The shadow of the disk must cover the pyranometer domes completely. However, to follow the sun's apparent motion, a power-driven tracking device is necessary. This can be done with the 2AP tracker, designed to track the sun under all weather conditions. More information about the combination of CM 21 and tracker is given in the 2AP tracker manual.

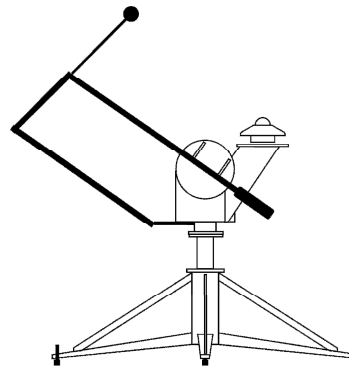

Figure 9 2AP tracker with pyranometer

Alternatively the use of a shadow ring is possible, however less accurate. The shadow ring intercepts the direct solar radiation some days without readjustment, but also a proportion of the diffuse sky radiation. Therefore corrections for this to the recorded data are necessary. Kipp & Zonen supplies a universal shadow ring CM 121 for all latitudes. In the CM 121 manual, installation instructions and correction factors are given.

3.2.5 Installation for measurement of albedo

The lower sensor of the albedometer construction, the pyranometer in the inverted position, measures the reflected solar radiation.

According to the WMO the height should be 1-2 meters above a surface covered by short cut grass.

The mounting device should not interfere too much with the field of view of the instrument. A construction as in figure 10 is suitable.

The upper screen prevents excessive heating of the pyranometer body by solar radiation.

The special screen for the lower CM 21 prevents direct illumination of the domes by the sun at sunrise and sunset. Kipp & Zonen can also supply this screen for a separate CM 21 (see chapter 9 for the part number).

Offset signals generated in the pyranometer by thermal effects (see paragraph 1.2.1) are a factor of 5 more significant in the measurement of the reflected radiation due to the lower irradiance level. The mast in the construction of figure 10 intercepts

a fraction $D / 2\pi S$ of the radiation coming from the ground.

In the most unfavourable situation (sun at zenith) the pyranometer shadow decreases the signal by a factor R^2 / H^2 .

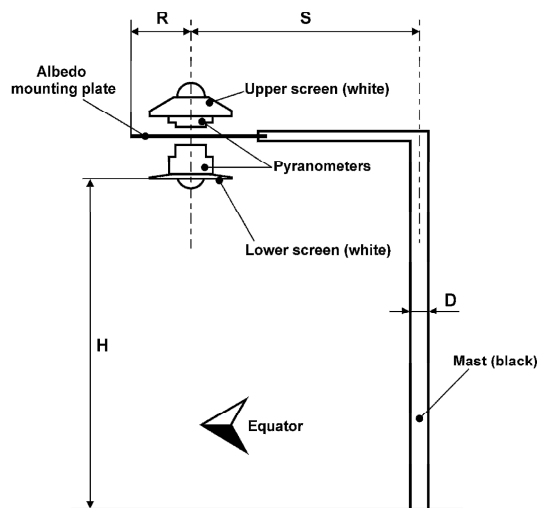

Figure 10 Albedo measurement construction

3.2.6 Underwater use

The CM 21 pyranometer is in principle watertight. However, the hemispherical water-glass and glass-air boundaries act as a negative lens. The parallel beam of direct solar radiation becomes strong divergent after the passage of the outer dome.

Consequently the intensity at the sensor is lower than outside the pyranometer. The sensitivity figure is not valid in this case but must be derived empirically.

3.3 ELECTRICAL CONNECTION

The CM 21 is provided with a 10 m cable with three leads and a shield covered with a black sleeve.

The colour code is:

red	=	plus
blue	=	minus
white	=	case

The shield is isolated from the case, so no shield-current can exist. Shield and white lead may be connected to the same ground at the readout equipment. The cable must be firmly secured to minimise spurious response during stormy weather (pressing the standard cable produces voltage spikes, a tribo electric effect and capacitance effect).

Kipp & Zonen pyranometer cables are of low noise type, however take care that the terminals '+' and '-' at a connection box have the same temperature, to prevent thermal EMF's. A box or connector with metal outer case is advised.

Looking at the circuit diagram of figure 11, it is clear that the impedance of the readout equipment is loading the thermistor circuit and the thermopiles. It can increase the temperature dependency of the pyranometer. The sensitivity is affected more than 0.1% when the load resistance is under 100 k Ω . For this reason we recommend the use of readout equipment with input impedance's of 1 M Ω or more such as potentiometric recorders, digital voltmeters, etc. The solar integrators and chart recorders from Kipp & Zonen meet these requirements. Long cables may be used, but the cable resistance must be smaller than 0.1% of the impedance of the readout equipment.

Kipp & Zonen supplies shielded low-noise extension cable up to lengths of 200 m. This extra length can be supplied fitted to the pyranometer when ordered, or can be coupled by waterproof connectors to the CM 21 cable. The lead resistance is 8 Ohm/100 m.

It is evident that application of attenuator circuits to modify the calibration factor is not recommended because the temperature response will also be affected. However, recorders with a variable voltage range can be set so that the result can be read directly in W/m^2 .

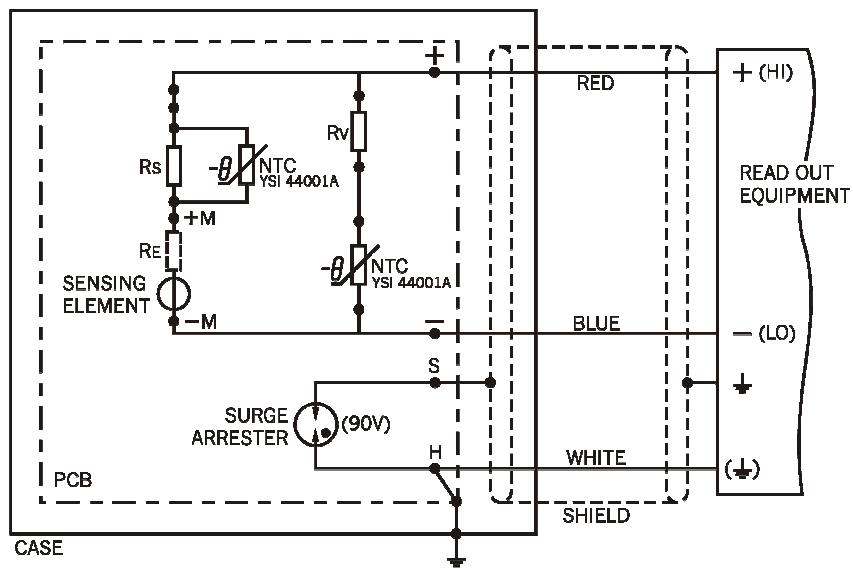

Figure 11 Circuit diagram of the CM 21 pyranometer and connection to readout equipment.

When an optional temperature sensor is built in (See specifications in appendix V en VI), the following colour code is used:

PT 100

- Yellow: Pt 100(combined with brown)
- Brown: Pt 100 (combined with yellow)
- Green: Pt 100 (combined with grey)
- Grey: Pt 100 (combined with green)

Thermistor

- Yellow
- Green

A considerable input bias current of the readout equipment can produce a voltage of several micro volts across the impedance of the pyranometer. The correct equipment “zero point” can be verified with a resistance replacing the pyranometer impedance at the input terminals.

The pyranometer can also be connected to a computer or data acquisition system. A low voltage analogue input module with A/D converter must be available then. The span and resolution of the A/D converter in the module must allow a system sensitivity of about 1 bit per W/m^2 . More resolution is not necessary during outdoors solar radiation measurements, because pyranometers exhibit offsets up to + or - $2 W/m^2$ due to lack of thermal equilibrium.

A surge arrester is installed to conduct induced lightning currents to the case. It is recommended to ground the case for this reason. The surge arrester is noble gas filled, has infinite impedance and recovers after breakdown. Breakdown voltage is 90 V. Peak pulse current is 10 kA.

For amplification of the pyranometer signal Kipp & Zonen recommends the CT 24 amplifier, available from Kipp & Zonen. This amplifier will convert the micro Volt output from the pyranometer into a standard 4 – 20 mA signal. Voltage output and amplification adjustment to the pyranometer calibration factor are also possible.

4 OPERATION

After completing the installation the pyranometer will be ready for operation.

The irradiance value ($E_{\downarrow Solar}$) can be simply computed by dividing the output signal (U_{emf}) of the pyranometer by its sensitivity ($S_{sensitivity}$) formula 1, or by multiplication of the voltage value with the reciprocal of the sensitivity. (Often called the calibration factor).

For calculation of the solar irradiance the following formula must be applied:

$$E_{\downarrow Solar} = \frac{U_{emf}}{S_{sensitivity}} \quad (formula\ 1)$$

$E_{\downarrow Solar}$	= Global radiation	[W/m ²]
U_{emf}	= Output of pyranometer	[μ V]
$S_{sensitivity}$	= Sensitivity of pyranometer	[μ V/W/m ²]

To be certain that the quality of the data is of a high standard, care must be taken with daily maintenance of the pyranometer. Once a voltage measurement is taken, nothing can be done to retrospectively improve the quality of that measurement.

Many years of experience has shown that pyranometer performance can be improved concerning the zero offset type A by using a proper ventilation system.

The Kipp & Zonen CV 2 ventilation unit is recommended as an optimal combination to minimise or eliminate this remaining error.

5 MAINTENANCE

Once installed the pyranometer needs little maintenance. The outer dome must be cleaned and inspected regularly, e.g. every morning. On clear windless nights the outer dome temperature of horizontally placed pyranometers will decrease, even to the dew point temperature of the air, due to IR radiation exchange with the cold sky. (The effective sky temperature can be 30°C lower than the ground temperature). In that case dew, glazed frost or hoar frost can be precipitated on the top of the outer dome and can stay there for several hours in the morning. An ice cap on the dome is a strong diffuser and increases the pyranometer signal drastically up to 50% in the first hours after sunrise. Hoar frost disappears due to solar radiation during the morning, but should be wiped of as soon as possible manually.

Another daily check is to ensure that the instrument is level and that there is no condensation inside the dome. If there is condensation the silica gel must be replaced, even when the colour is still blue. Apparently the location requires very fresh silica gel and a low dew point inside.

It is normal in humid areas to replace the desiccant twice a year. The exchange interval is affected by humidity, change in air pressure and the amount of temperature changes. When the blue silica gel in the drying cartridge is turned pink (normally after several months), it must be replaced by active material. Pink silica gel can be activated again in an oven at 130°C within several hours.

Apart from that it is good to visit the pyranometer (or any other sensor) regularly to check its condition. (desiccant, dirt on dome, levelling of instrument and condition of cabling)

Some tips to check when changing the desiccant:

- Make sure the surfaces of the pyranometer and the cartridge that touch the rubber ring are clean (corrosion can do a lot of harm here and dirt, in combination with water, can cause this)

- The rubber ring is normally coated with a silicon grease (Vaseline will also do) to make the seal even better. If the rubber ring looks dry apply some grease to it.
- Check that the metal spring that retains the drying cartridge applies enough force. It is normal that you have to use two hands to open and close it.

It is very difficult to make the pyranometers hermetically sealed. The only way to do this properly is to put the inside of the instrument under pressure. (> 1.0 Bar), but this has to be checked at yearly intervals. So, due to pressure differences inside and outside the instrument there will always be some exchange of (humid) air.

In some networks, the exposed dome of the pyranometer is ventilated continuously by a blower to keep the dome above dew point temperature. The need for heating strongly depends upon local climatological circumstances.

Generally heating is advised during cold seasons when frost and dew can be expected.

The ventilation also decreases the sensitivity to thermal radiation (zero offset type A) by a factor of 2 or more.

The Kipp & Zonen CV 2 ventilation unit is specially designed for accurate unattended operation under most weather conditions.

6 CALIBRATION

6.1 INITIAL CALIBRATION

The ideal pyranometer should always have a constant ratio of voltage output to irradiance level (outside the instrument in the plane of the sensing element). This ratio is called sensitivity (*S_{sensitivity}*) or responsivity.

The sensitivity figure of a particular pyranometer is unique. It is determined in the manufacturer's laboratory by comparison against a standard pyranometer.

The standard pyranometer is calibrated outdoors regularly at the World Radiation Centre (Davos, Switzerland). The spectral content of the laboratory lamp differs from the outdoors solar spectrum at the Radiation Centre of course. However, this has no consequences for the transfer of calibration, because standard and unknown pyranometer have the same black coating and glass domes.

The supplied sensitivity figure is valid for the following conditions:

- An ambient temperature of 20°C.
- For a horizontal pyranometer as well as for a tilted pyranometer.
- Normal incident radiation of 500 W/m².
- Spectral content as clear sky solar radiation.

6.2 RECALIBRATION

Pyranometer sensitivity changes with time and with exposure to radiation. Periodic calibration (at least every two years) is advised.

Transfer from another pyranometer in the laboratory is only possible when both pyranometers are of the same type and have the same glass domes and optical coatings. Kipp & Zonen can recalibrate pyranometers according to this method for a charge. To send back a pyranometer to Kipp & Zonen

for recalibration the use of the recalibration form in appendix VII is recommended.

Accurate calibrations can also be done outdoors under clear conditions by reference to a standard pyrhelimeter. Many National Weather Services have calibration facilities. Their standard pyrhelimeter is compared with the World Radiometric Reference (maintained at Davos, Switzerland) embodied by several absolute pyrhelimeters (black body cavity type).

The comparisons are indoors or at one of the regional Radiation Centres, see Appendix III.

These institutes sometimes offer calibration facilities.

A summary of calibration methods is also found in the WMO guide of 1996.

There are several procedures for transferring calibration from a narrow field of view instrument (pyrheliometer) to a wide field of view instrument (pyranometer). E.g. the direct component of the solar radiation is eliminated temporarily from the pyranometer by shading the whole outer dome of the instrument with a disk. There is however no thermal equilibrium with this method and some pyranometer models show zero-offset drift.

There is another procedure, during which the unknown pyranometer remains in its normal operating condition. This 'component' method involves measuring the direct component with a pyrhelimeter and the diffuse component with a disk shaded pyranometer. As, during a clear day, the diffuse radiance is only about 10% of the global radiation, the sensitivity of the second pyranometer does not need to be known very accurately. Both procedures are suitable to obtain a working standard pyranometer. The latter is extensively described in International standard ISO 9846.

Transfer from the working standard pyranometer to other pyranometers can be done in sunlight. The pyranometers must be mounted side by side so that each views the same sky dome. It is desirable to integrate, or average, the outputs over a period of time and then compute the calibration constants on the basis of these averages. This reduces the errors due to changing parameters during the day. See for detailed procedure International Standard ISO 9847.

6.3 CALIBRATION PROCEDURE AT KIPP & ZONEN

6.3.1 The facility

The artificial sun is a good quality film sun (Osram) fed by an AC voltage stabiliser. It embodies a 1000 W tungsten-halogen lamp with compact filament. The built-in ventilator allows continuous operation. Behind the lamp is a diffuse reflector with a diameter of 7.5 cm. The reflector is 120 cm above the pyranometers, so the apparent sun diameter is 3.5° .

To minimise stray light from the walls and the operator, the light is limited to a small cone around the two pyranometers. The unknown pyranometer 'a' and the standard pyranometer 'b' are placed side by side on a small table. The table can rotate to interchange the positions (1 and 2) of the pyranometers. The lamp is centred on the rotating axis of this table. Actually there is no normal incidence of the radiation. But the angle of incidence is the same for both pyranometers (3°), so this cannot give rise to errors. The pyranometers are not levelled with the screws, but placed on their bases. The effect of a small tilt is almost zero (Compare $\cos. 3^\circ = 0.9986$ and $\cos. 4^\circ = 0.9976$). The irradiance of the pyranometers is approx. 500 W/m^2 . The colour temperature of the light is 3300 K.

6.3.2 Procedure

After illuminating for 30 s, the output voltages of both pyranometers are integrated over 30 s with a solar integrator. Next, both pyranometers are covered by a blackened 'hat'. After 30 s the zero offset signal of both pyranometers is integrated again during 30 s.

The problem of the zero offset is described below. This zero offset has to be subtracted to obtain the response due to illumination. So we get response A and B respectively.

The irradiance at position 1 (pyranometer 'a') may be slightly different from that at position 2 (pyranometer 'b') due to asymmetry in the lamp optics etc. Therefore the pyranometers are interchanged and the whole procedure is repeated. We get another pair of values: A' and B'.

6.3.3 Calculation

The sensitivity of the unknown pyranometer is calculated with the formula 2:

$$S_a = \frac{A + A'}{B + B'} \cdot S_b \quad (\text{formula 2})$$

S_b	= Sensitivity of the standard pyranometer at 20 °C.
A	= Output of pyranometer at position 1
A'	= Output of pyranometer at position 2
B	= Output of standard pyranometer at position 2
B'	= Output of standard pyranometer at position 1
S_a	= Sensitivity of the pyranometer at 20 °C.

Output = (mean value at 100% response minus zero offset signal)

6.3.4 Zero offset

The lamp housing and diaphragms are emitting long wave infrared radiation, which heats up the outer glass dome and also, indirectly, the inner dome. When the pyranometers are shaded, there still remains a small signal up to + 20 μ V due to longwave infrared radiation from the inner dome to the sensor. This zero offset is decreasing with a time constant (1/e) of several minutes.

A zero offset was also embodied in the response due to illumination. To correct for this unwanted response, the zero offset read after 30+30 s shading is subtracted.

6.3.5 Traceability to World Radiometric Reference

Working standard pyranometers are maintained at Kipp & Zonen. Each standard pyranometer is characterised.

Linearity, temperature dependence curve and directional response are well known.

The working standard pyranometers are calibrated each year at the World Radiation Centre in Davos, Switzerland, periodically according to the component method.

7 FREQUENTLY ASKED QUESTIONS (FAQ's)

The most frequently asked questions are listed below. For an update refer to the Kipp & Zonen web page: <http://www.kippzonen.com>

1. Negative output during night time measurements?

This error is related to the zero offset type A. Normally this zero offset is present when the inner dome has a different temperature from the cold junctions of the sensor. Practically this is always the case when there is a clear sky. Because of the low effective sky temperature ($<0^{\circ}\text{C}$) the earth surface emits roughly 100 W/m^2 longwave infrared radiation upwards. The outer glass dome of a pyranometer also has this emission and is cooling down several degrees below air temperature (the emissivity of glass for the particular wavelength region is nearly 1). The emitted heat is attracted from the body (by conduction in the dome), from the air (by wind) and from the inner dome (through infrared radiation). The inner dome is cooling down too and will attract heat from the body by conduction and from the sensor by the net infrared radiation. The latter heat flow is opposite to the heat flow from absorbed solar radiation and causes the well known zero depression at night. This negative zero offset is also present on a clear day, however, hidden in the solar radiation signal.

Zero offset type A can be checked by placing a light and IR reflecting cap over the pyranometer. The response to solar radiation will decay with a time constant ($1/e$) of 1 s, but the dome temperature will go to equilibrium with a time constant of several minutes. So after half a minute the remaining signal represents mainly zero offset type A.

Good ventilation of domes and body is the solution to reducing zero offsets even further. Kipp & Zonen advises the CV 2 for optimal ventilation and suppression of zero offset type A. Using the CV 2 zero offset type A will be less than 5 W/m^2 .

2. Maximum and minimum irradiation quantities?

Due to possible reflection from clouds the global irradiance at sea level can rise above the extraterrestrial irradiance of 1367 W/m^2 at the top of the atmosphere. Values up to 1500 W/m^2 have been reported due to focussing effects of clouds.

Because the clouds move, this irradiance value mostly appears as short events of some minutes duration.

3. What is the primary entry point for humidity ?

The desiccant cartridge and cable glands have equal chances to transport some moisture but also the silicon glue of the domes is not fully watertight. However, normally the cable gland is never touched while the cartridge is removed frequently.

So when no care is taken (see above) one can easily make the desiccant cartridge the primary entry point.

Note. Water transport through the cable is also possible when the open end of the cable and the connected device are in a humid environment

8 TROUBLE SHOOTING

The following contains a procedure for checking the instrument in case it appears that it does not function as it should.

Trouble shooting:

Output signal fails or shows improbable results:

- Check the wires, whether they are properly connected to the readout equipment.
- Check the instrument location. Are there any obstructions that cast a shadow on the instrument by blocking the direct sun during some part of the day.
- Check the window, it should be clear. If water is deposited on the inside, please change the desiccant. If too much water is deposited the instrument should be dried internally.
- Check instrument impedance (40 – 100 Ohm)
- Check datalogger or integrator offset by connecting a dummy load (40 – 100 Ohm resistor). This should give a “zero” reading.

If water or ice is deposited to the outside, clean the outside. Probably water droplets will evaporate in less than one hour.

Any visible damage or malfunction should be reported to your dealer, who will suggest appropriate action.

9 PART NUMBERS / SPARE PARTS / OPTIONS

Description	Part no.
Measuring/compensating cell in housing covered by inner glass dome	0305-161
Outer glass dome 50 mm with metal ring	0305-162
Rubber ring for outer glass dome of CM 21	2132-426
Screen (plastic)	0305-166
Levelling screw (2 required per pyranometer)	0012-117
Fixed foot	0012-116
Level with holder	2993-100/ 0012-108
Complete drying cartridge consisting of:	
Clamp-Spring	0305-165
Drying cartridge (without cover)	9012-106
Cover for cartridge	9012-107
Rubber ring	2132-153
Optional:	
Pt 100 Temperature sensor integrated in pyranometer	
10K Thermistor integrated in pyranometer	

Description	Part no.
Mounting plate for 4 unventilated sensors (2 upper and 2 lower)	0012 092
10 meters cable extension and connectors	0305 666
15 meters cable extension and connectors	0305 631
20 meters cable extension and connectors	0305 632
25 meters cable extension and connectors	0305 633
30 meters cable extension and connectors	0305 634
50 meters cable extension and connectors	0305 635
75 meters cable extension and connectors	0305 636
100 meters cable extension and connectors	0305 637
200 meters cable extension and connectors	0305 638

APPENDIX I CLASSIFICATION ACCORDING TO WMO GUIDE 1996

Characteristics	CM 21	High quality	Good quality	Moderate quality
ISO 9060 classification		Secondary standard	First class	Second class
Response time (95 percent response)	5 s	< 15 s	< 30 s	< 60 s
Zero offset: (a) Response to 200 W/m ² net thermal radiation (ventilated) (b) Response 5 K/h change in ambient temperature	<± 5 W/m ² (with CV 2) <± 2 W/m ²	<± 7 W/m ² <± 2 W/m ²	<± 15 W/m ² <± 4 W/m ²	<± 30 W/m ² <± 8 W/m ²
Resolution (smallest detectable change)	<± 0.5 W/m ²	± 1 W/m ²	± 5 W/m ²	± 10 W/m ²
Stability (change per year, percentage of full scale)	< 0.5	± 0.8	± 1.5	± 3.0
Directional response of beam radiation (The range of errors caused by assuming that the normal incidence responsivity is valid for all directions when measuring, from any direction, a beam radiation whose normal incidence irradiance is 1000 W/m ²)	<± 10 W/m ²	<± 10 W/m ²	<± 20 W/m ²	<± 30 W/m ²
Temperature response (percentage of maximum due to any change of ambient temperature within an interval of 50 K)	<± 1 -20°C—+50°C	<± 2	<± 4	<± 8
Non-linearity (percentage deviation from the responsivity at 500 W/m ² due to any change of irradiance within the range 100 to 1000 W/m ²)	<± 0.2	<± 0.5	<± 1	<± 3
Spectral sensitivity (percentage of deviation of the product of spectral absorptance and spectral transmittance from the corresponding mean within the range of 0.35 to 2µm)	<± 2	<± 2	<± 5	<± 10
Tilt response (percentage deviation from the responsivity at 0° tilt, horizontal, due to change in tilt from 0° to 90° at 1000 W/m ² irradiance)	<± 0.2	<± 0.5	<± 2	<± 5
Achievable uncertainty, 95 percent confidence level				
Hourly totals	2 %	3%	8%	20%
Daily totals	2 %	2%	5%	10%

APPENDIX II RADIOMETRIC LEVELLING

This must be done in the laboratory by mounting the instrument on a stand that can be rotated around an axis that is accurately vertical and passes through the centre of the receiving surface. The instrument then is illuminated by a lamp so that radiation falls at an elevation of approximately 15° to the horizontal; the lamp should be fed by a constant voltage supply. The output from the radiation instrument is measured at various azimuths and the level of the instrument adjusted independently of that of the rotating stand until the least possible variation is obtained as the instrument is rotated around the vertical axis. Once this has been done, the spirit level is marked so that the correct level can be found back outdoors.

APPENDIX III LIST OF WORLD AND REGIONAL RADIATION CENTRES

World Radiation Centres

Davos (Switzerland)
St. Petersburg (Russia)

Regional Radiation Centres

Region I Africa:

Cairo (Egypt)
Khartoum (Sudan)
Kinshasa (Zaire)
Lagos (Nigeria)
Tamanrasset (Algeria)
Tunis (Tunisia)

Region II Asia:

Poona (India)
Tokyo (Japan)

Region III South America:

Buenos Aires
(Argentina)

Region IV North and Central America:

Toronto (Canada)
Washington (U.S.A.)

Region V South west Pacific:

Aspendale (Australia)

Region VI Europe:

Bracknell (United Kingdom)
Budapest (Hungary)
Davos (Switzerland)
St. Petersburg (Russia)
Norrköping (Sweden)
Trappes/Carpentras
(France)
Uccle (Belgium)
Potsdam (Germany)

APPENDIX IV PYRANOMETER MEASUREMENT REPORT

Routine measurement of directional error during final inspection.

Mean cosine error of each new CM 21 pyranometer is measured by a simple routine.

The pyranometer base is placed against the vertical turntable of a goniometer in the parallel (0,5°) beam of a sun simulator. Voltage output U(z) is measured for beam incidence (zenith) angles of 0°, 40°, 60°, 70° and 80° coming in over azimuth East (cable pointing to North). Next the pyranometer output U(-z) is measured for incidence angles of -80°, -70°, -60°, -40° and 0° for azimuth North. The dark signal is measured at the beginning of the routine in the middle and at the end. For each beam incident angle the dark signal is interpolated.

During the CM 21 measurement cycle a check is done on the azimuth error at 40° and 70° by measuring voltages for azimuth-directions E, N, W and S. Also at -70° and -40° this azimuth error is measured and the mean of both azimuth measurements cancels out eventual error in the 0° position.

With the extended procedure at both 40° and -40° and 70° and -70° the specific cosine error δ_{\cos} for 8 azimuth directions (40° E, N, W, S and 70° E, N, W, S) can be calculated according to formula 1 and verified whether it is within ± 5 W/m².

The applied formula for the relative cosine error is:

U(0°) Pyranometer output voltage for normal incidence
 U(z) Pyranometer output voltage for angles (z)
 Zero(z) Dark signal for angles (z)

$$\delta_{\cos} = \frac{\frac{U(z)+U(-z)}{2} - zero(z)}{\left(\frac{U(0^\circ) + U(0^\circ)}{2} - zero(z)\right) \cdot \cos(z)} \cdot 100\% \quad (\text{formula 3})$$

Relative cosine error at azimuth angle

Angle	North	West	South	East
40	-0.27%	0.30%	0.38%	-0.18%
60	0.61%			
70	-0.62%	0.66%	1.09%	0.10%
80	0.62%			

Absolute cosine error for 1000 W/m² beam radiation

Angle	North	West	South	East
40	-2.04 W/m ²	2.32 W/m ²	2.89 W/m ²	-1.40 W/m ²
60	3.06 W/m ²			
70	-2.11 W/m ²	2.25 W/m ²	3.73 W/m ²	0.35 W/m ²
80	1.09 W/m ²			

The above data is an example which will differ for each pyranometer.

APPENDIX V THERMISTOR SPECIFICATIONS

YSI thermistor 44031 Resistance versus Temperature in °C

Temperature [°C]	Resistance [Ω]	Temperature [°C]	Resistance [Ω]	Temperature [°C]	Resistance [Ω]
-30	135200	0	29490	30	8194
-29	127900	1	28150	31	7880
-28	121100	2	26890	32	7579
-27	114600	3	25690	33	7291
-26	108600	4	24550	34	7016
-25	102900	5	23460	35	6752
-24	97490	6	22430	36	6500
-23	92430	7	21450	37	6258
-22	87660	8	20520	38	6026
-21	83160	9	19630	39	5805
-20	78910	10	18790	40	5592
-19	74910	11	17980	41	5389
-18	71130	12	17220	42	5193
-17	67570	13	16490	43	5006
-16	64200	14	15790	44	4827
-15	61020	15	15130	45	4655
-14	58010	16	14500	46	4489
-13	55170	17	13900	47	4331
-12	52480	18	13330	48	4179
-11	49940	19	12790	49	4033
-10	47540	20	12260	50	3893
-9	45270	21	11770	51	3758
-8	43110	22	11290	52	3629
-7	41070	23	10840	53	3504
-6	39140	24	10410	54	3385
-5	37310	25	10000	55	3270
-4	35570	26	9605	56	3160
-3	33930	27	9227	57	3054
-2	32370	28	8867	58	2952
-1	30890	29	8523	59	2854

APPENDIX VI PT-100 SPECIFICATIONS

Pt-100 Resistance versus Temperature in °C

Temperature [°C]	Resistance [Ω]	Temperature [°C]	Resistance [Ω]	Temperature [°C]	Resistance [Ω]
-30	88.22	0	100.00	30	111.67
-29	88.62	1	100.39	31	112.06
-28	89.01	2	100.78	32	112.45
-27	89.40	3	101.17	33	112.83
-26	89.80	4	101.56	34	113.22
-25	90.19	5	101.95	35	113.61
-24	90.59	6	102.34	36	113.99
-23	90.98	7	102.73	37	114.38
-22	91.37	8	103.12	38	114.77
-21	91.77	9	103.51	39	115.15
-20	92.16	10	103.90	40	115.54
-19	92.55	11	104.29	41	115.93
-18	92.95	12	104.68	42	116.31
-17	93.34	13	105.07	43	116.70
-16	93.73	14	105.46	44	117.08
-15	94.12	15	105.85	45	117.47
-14	94.52	16	106.24	46	117.85
-13	94.91	17	106.63	47	118.24
-12	95.30	18	107.02	48	118.62
-11	95.69	19	107.40	49	119.01
-10	96.09	20	107.79	50	119.40
-9	96.48	21	108.18	51	119.78
-8	96.87	22	108.57	52	120.16
-7	97.26	23	108.96	53	120.55
-6	97.65	24	109.35	54	120.93
-5	98.04	25	109.73	55	121.32
-4	98.44	26	110.12	56	121.70
-3	98.83	27	110.51	57	122.09
-2	99.22	28	110.90	58	122.47
-1	99.61	29	110.28	59	122.86

APPENDIX VII RECALIBRATION SERVICE

Pyranometers, UV-meters, Pyrgeometers & Sunshine duration sensors

Kipp & Zonen solar radiation measurement instruments comply with the most demanding international standards. In order to maintain the specified performance of these instruments, Kipp & Zonen recommends calibration of their instruments at least every two years.

This can be done at the Kipp & Zonen factory. Here, recalibration to the highest standards can be performed at low cost. Recalibration can usually be performed within four weeks. If required, urgent recalibration can be accomplished in three weeks or less (subject to scheduling restrictions). Kipp & Zonen will confirm the duration of recalibration at all times. Please note that special quantity recalibration discounts are available.

For your convenience we added three fax forms to schedule the recalibration of your instrument(s) at Kipp & Zonen.



RECALIBRATION FORM

NAME :
COMPANY/INSTITUTE :
ADDRESS :
POSTCODE +CITY :
COUNTRY :
PHONE :
FAX :

- I would like to receive a price list for recalibration
I would like to submit my instruments for recalibration

Table with 3 columns: Type/Model, Qty, Requested delivery time. Includes rows for sending instruments and receiving instruments back.

Conformation by Kipp & Zonen
Yes, the dates are acceptable to us
No, unfortunately the dates do not fit into our calibration schedule. We suggest the following dates:

Fax +31-15-2620351

or mail to:

Kipp & Zonen P.O. Box 507 2600AM
Delft The Netherlands



RECALIBRATION FORM

NAME :
COMPANY/INSTITUTE :
ADDRESS :
POSTCODE +CITY :
COUNTRY :
PHONE :
FAX :

- I would like to receive a price list for recalibration
I would like to submit my instruments for recalibration

Table with 3 columns: Type/Model, Qty, Requested delivery time. Includes fields for sending instruments to Kipp & Zonen and receiving instruments back.

Conformation by Kipp & Zonen
Yes, the dates are acceptable to us
No, unfortunately the dates do not fit into our calibration schedule. We suggest the following dates:

Fax +31-15-2620351

or mail to:

Kipp & Zonen P.O. Box 507 2600AM
Delft The Netherlands



RECALIBRATION FORM

NAME :
COMPANY/INSTITUTE :
ADDRESS :
POSTCODE +CITY :
COUNTRY :
PHONE :
FAX :

- I would like to receive a price list for recalibration
I would like to submit my instruments for recalibration

Table with 3 columns: Type/Model, Qty, Requested delivery time. Includes fields for sending instruments to Kipp & Zonen and receiving instruments back.

Conformation by Kipp & Zonen
Yes, the dates are acceptable to us
No, unfortunately the dates do not fit into our calibration schedule. We suggest the following dates:

Fax +31-15-2620351

or mail to:

Kipp & Zonen P.O. Box 507 2600AM
Delft The Netherlands