

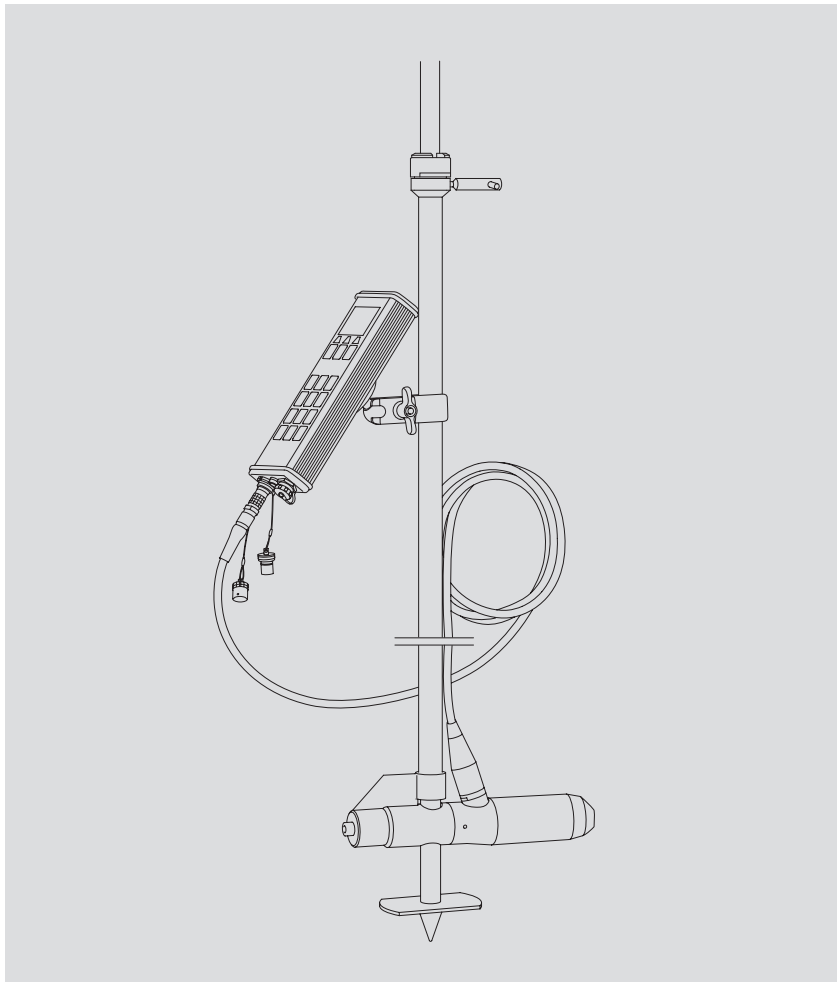

Operating instructions
**Acoustic, digital
current meter OTT ADC**



English

We reserve the right to make technical changes and improvements without notice.

WARRANTY AND ASSISTANCE

This equipment is warranted by CAMPBELL SCIENTIFIC (CANADA) CORP. ("CSC") to be free from defects in materials and workmanship under normal use and service for **twelve (12) months** from date of shipment unless specified otherwise. ***** **Batteries are not warranted.** ***** CSC's obligation under this warranty is limited to repairing or replacing (at CSC's option) defective products. The customer shall assume all costs of removing, reinstalling, and shipping defective products to CSC. CSC will return such products by surface carrier prepaid. This warranty shall not apply to any CSC products which have been subjected to modification, misuse, neglect, accidents of nature, or shipping damage. This warranty is in lieu of all other warranties, expressed or implied, including warranties of merchantability or fitness for a particular purpose. CSC is not liable for special, indirect, incidental, or consequential damages.

Products may not be returned without prior authorization. To obtain a Return Merchandise Authorization (RMA), contact CAMPBELL SCIENTIFIC (CANADA) CORP., at (780) 454-2505. An RMA number will be issued in order to facilitate Repair Personnel in identifying an instrument upon arrival. Please write this number clearly on the outside of the shipping container. Include description of symptoms and all pertinent details.

CAMPBELL SCIENTIFIC (CANADA) CORP. does not accept collect calls.

Non-warranty products returned for repair should be accompanied by a purchase order to cover repair costs.



CAMPBELL SCIENTIFIC
C A N A D A C O R P .

11564 - 149 street - edmonton - alberta - T5M 1W7
tel 780.454.2505 fax 780.454.2655

www.campbellsci.ca

Table of contents

1 Scope of supply	5
2 Safety information	6
3 Introduction	7
3.1 Measurement principle	7
3.2 Measurement process	7
4 System components	8
4.1 Sensor	
4.2 Handheld unit	9
5 Starting up the OTT ADC	14
5.1 Ensuring power supply	14
5.2 Starting up the handheld unit	15
5.3 Starting up the sensor	17
5.4 Connecting the sensor to the handheld unit	21
6 Preparing and carrying out discharge measurement	22
6.1 Preparing for measurement	22
6.2 Carrying out measurement	23
6.3 Transferring data to the PC	26
7 Menu functions on the handheld unit	27
7.1 Main menu	27
7.2 Discharge measuring menu	28
7.3 Depth calibration menu	38
7.4 View data menu	39
7.5 Delete files menu	39
7.6 System status menu	40
7.7 System settings menu	40
7.8 Advanced menu	42
8 Ensuring data quality	43
8.1 Angle of flow	43
8.2 Temperature compensation	44
8.3 Depth calibration	44
8.4 Internal quality check	44
9 Processing data with OTT QReview	46
9.1 System requirements	46
9.2 Installing USB device drivers and software	46
9.3 Transferring data to the PC	48
9.4 Processing and exporting data	48
9.5 Menu functions in OTT QReview	49
10 Maintenance work	50
10.1 Handheld unit	50
10.2 Sensor	50
11 Warnings and error messages	51
11.1 Warnings	51
11.2 Critical error messages	52
12 Troubleshooting	53
13 Technical Data	54
14 Order numbers and accessories	56

Appendix A – Theory and practical suggestions for discharge measuring with the OTT ADC	58
A.1 Overview: Methods for velocity measurement	58
A.2 Overview: Methods of discharge calculation	61
Appendix B – Flow velocity measurement with the OTT ADC (functional principle)	64
Appendix C – Firmware upgrade	65
Appendix D – Standard settings	67
Appendix E – Repair	68
Appendix F – Note on the disposal of old units	69
Appendix G – Declaration of conformity	70
Appendix H – Overview main menu	71
H.1 Main menu part 1	71
H.2 Main menu part 2	72

1 Scope of supply

- ▶ OTT ADC
 - 1 acoustic, digital current meter, consisting of:
 - sensor with sensor connection cable and mechanical adapter to attach the sensor to the measuring rod
 - handheld unit with integrated battery and charging unit
 - rod bracket for attaching the handheld unit to measuring rods (universal attachment)
 - power supply with AC/DC converter and connection for charging cable
 - charging cable
 - power cable for power supply
 - USB cable for connecting the handheld unit to the PC
 - OTT ADC brief instructions
 - transport case
 - factory acceptance test certificate (FAT)

 - Optional:
 - universal power adapter set for power supply (travel plug)
 - Optional:
 - adapter for 12 V (vehicle connection)

- ▶ CD ROM
 - 1 CD-ROM with the following elements:
 - user firmware for the handheld unit
 - processing software OTT QReview incl. operating manual available online
 - USB driver for the connection between the handheld unit and the PC
 - brief instructions for OTT ADC as PDF file
 - operating instructions for OTT ADC as PDF file
 - Acrobat Reader

2 Safety information

- ▶ Read these operating instructions through before using the OTT ADC for the first time. Make sure you are familiar with the initial startup and operation of the device. Retain these operating instructions for later reference.
- ▶ The OTT ADC is used for discharge measuring in open waterways. Only use the OTT ADC as described in these operating instructions!
- ▶ During discharge measuring, observe the accident prevention regulations applicable in your country!
- ▶ Keep to the electrical and measurement specifications described in the technical data (see Chapter 13 "Technical Data")!
- ▶ Do not make any technical changes to the sensor or handheld unit of the OTT ADC and do not open the devices! Otherwise you will lose all guarantee rights!
- ▶ Carry out maintenance work as recommended and at regular intervals (see Chapter 10 "Maintenance work").
- ▶ Have a defective device inspected and repaired by the OTT repair center. Never carry out repairs yourself. This also applies to replacing batteries and the sensor connection cable.
- ▶ The handheld unit and sensor must have the same serial number in order to function correctly. Therefore, never use devices with differing serial numbers.
- ▶ Only attach the power supply to the handheld unit of the OTT ADC. Never use for other USB standard devices, as differences in the output voltage will cause damage to the device!
- ▶ Dispose of the OTT ADC properly after taking out of service. Never dispose of the device in the normal household waste (see Appendix F "Note on the disposal of old units").

3 Introduction

The OTT ADC is a mobile, acoustic current meter for measuring point velocities in open waterways. It is used for discharge measuring with the classic verticals process with conventional rods.

During a discharge measurement, the OTT ADC measures not only the vertical velocity distribution at the verticals but also the water depth and the respective depth of the sensor. It calculates the average speed at the verticals from the measurements and also the partial flow in a flow segment in accordance with European standard EN ISO 748. Finally, it calculates the sum of all partial flows to determine the complete discharge.

Fig. 1 OTT ADC with sensor and handheld unit to control the measurement and to receive the measurement results

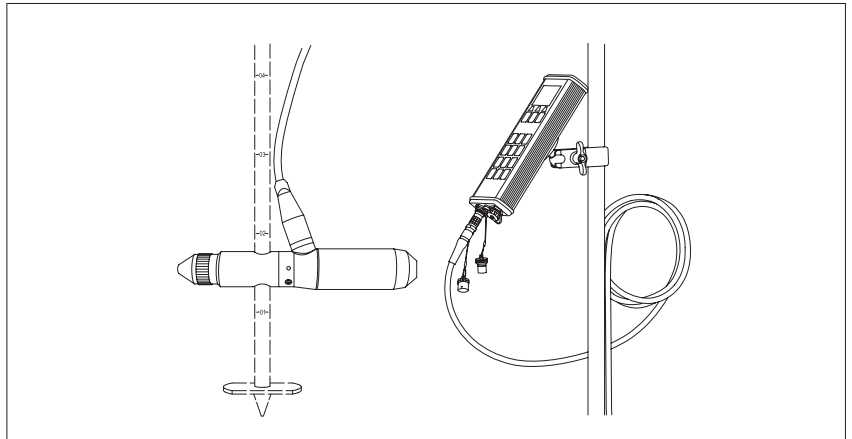

3.1 Measurement principle

There are two ultrasonic transducers in the sensor head of the OTT ADC. While measuring the flow velocity, these transmit ultrasonic signals, which are reflected by the waterway particles and return as echo signals. The echo signals are received by the transducers and digitalized by a digital signal processor (DSP) as an echo pattern. After a short pause the process is repeated so that there is a second echo pattern. The DSP checks both echo patterns for similarity using a mathematical procedure and calculates their time difference. The difference is then used to calculate the flow velocity.

3.2 Measurement process

Before beginning the measurement, the user enters the relevant parameters for the specific station and the required measuring and calculation methods via the handheld unit.

During the measurement the graphical user interface on the handheld unit leads the user step by step from the first to the last measure point. In the process, the communication between the handheld unit and the sensor is via the sensor connection cable. Relevant parameters and measurement results for a station are saved in a specific file in the handheld unit.

After the measurement, the user can load the data onto the PC, prepare and process it using the processing software OTT QReview.

4 System components

The OTT ADC mainly consists of the following components:

- ▶ Sensor
- ▶ Handheld unit

Further components are, for example, an adapter for connecting the handheld unit and sensor to the measuring rod, the power supply, a charging cable and connection cables for connecting the handheld unit to the sensor and PC.

Please note

The serial numbers of the sensor and handheld unit must correspond. The handheld unit contains calibration data for the temperature sensor and the pressure cell of the relevant sensor. Therefore, only use a sensor and handheld unit with the same serial number and never exchange them between devices!

4.1 Sensor

The sensor is the base element of the OTT ADC. The important necessary assemblies for measuring speed, water depth and water temperature can be found in it. It consists of the following components:

- ▶ Sensor head with two integrated ultrasonic transducers, temperature sensor and other assemblies
- ▶ Sensor body with integrated pressure cell and connector for the sensor connection cable
- ▶ Sensor end piece as adapter for the rod bracket with fixing sleeve for attachment to the rods

The serial number of the sensor is engraved into the rear part of the sensor body, beneath the connection for the sensor connection cable.

Fig. 2: Components of the sensor

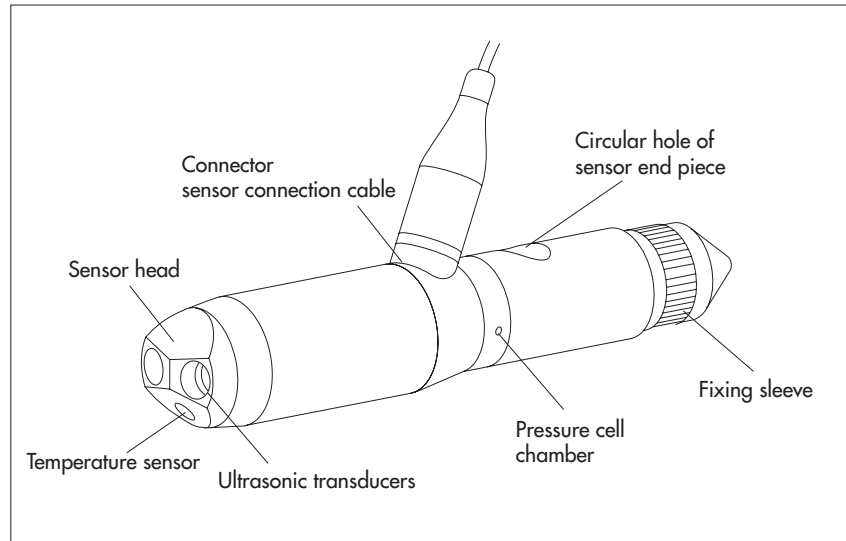

The sensor connection cable is fixed to the sensor body. It is used to connect the sensor to the handheld unit for transmitting data and electrical power.

Fig. 3: Connector for sensor connection cable

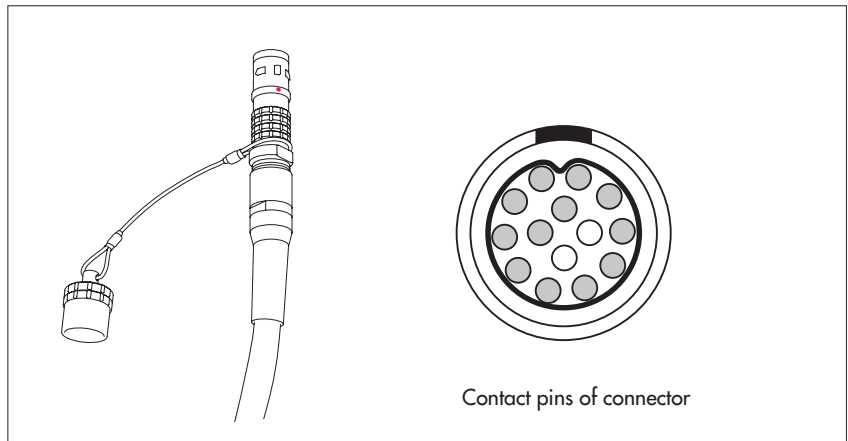

Please note

Never replace the sensor connection cable yourself! For a professional replacement of the sensor connection cable, send the device to the OTT repair center if necessary.

4.2 Handheld unit

The handheld unit is the interface between user and sensor. The user enters the necessary parameters for the station and measuring method with the handheld unit. The graphical user interface of the unit leads the user through the measurement and provides measurement information.

The handheld unit consists of the following components:

- ▶ Digital board for processing the signals received
- ▶ CPU board for data processing and output
- ▶ Fixed battery pack (rechargeable battery) for electrical supply
- ▶ Charging unit
- ▶ Display
- ▶ Keyboard
- ▶ Loudspeaker for key and feedback signals
- ▶ Interfaces for communication with the sensor and for data transfer to the PC
- ▶ On/off switch

Please note

The serial number is printed on the type plate on the rear of the handheld unit. You can also query the serial number via the menu of the handheld unit.

See menu

Main menu [2/2]/System Status/Serial Nr.

The following figure shows components that are important for working with the handheld unit:

Fig. 4: Handheld unit with display, operating keys and keyboard

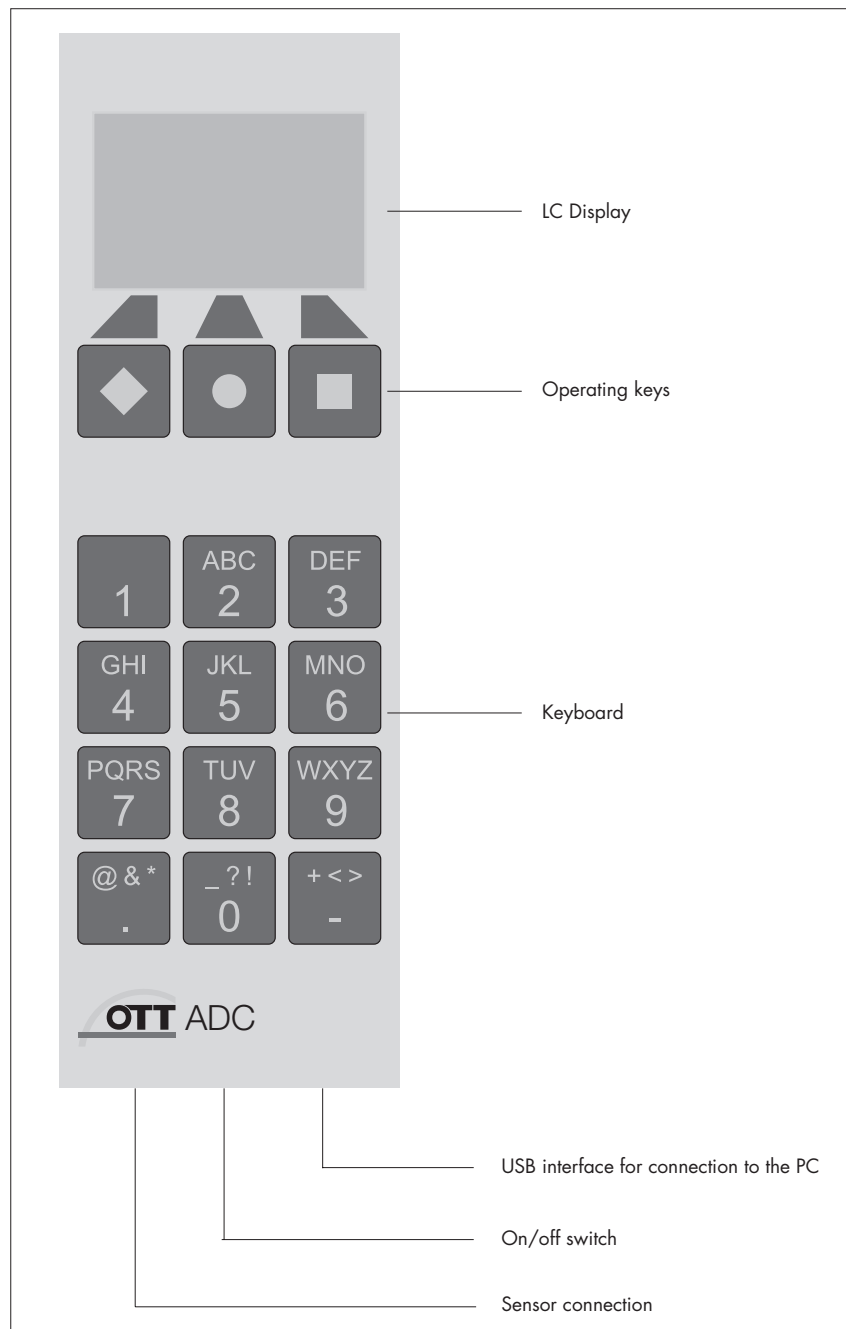

4.2.1 Display screen

Saved data and current information on the measurement running are shown on the graphical user interface of the display.

Fig. 5: Display screen during the measurement (example)

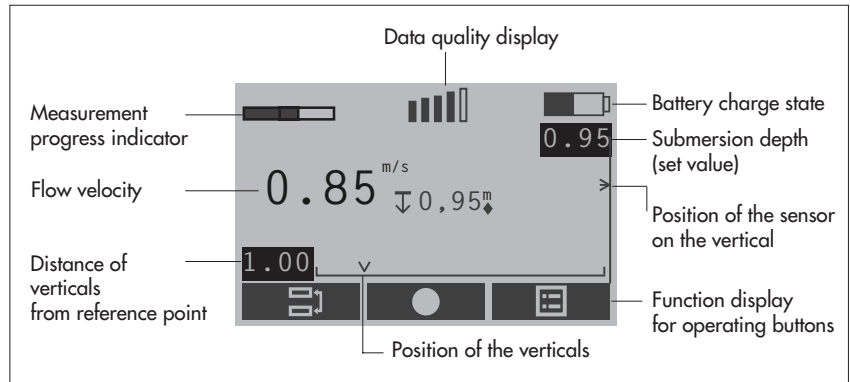

Units

Water and sensor depth as well as various positions and distances are shown in separate displays on the handheld unit without units. Depths and distances are measured in meters (m) or feet (ft). The unit is specified when the handheld unit is set (see Chapter 5.2.1 "Setting the handheld unit").











4.2.2 Display symbols

Display symbols provide information on the system status and the current measurement. In the course of the discharge measurement being run, they also give information to the user on the correct positioning of the sensor.

	Battery charging state		Distance of verticals from cross-section zero point
	Data quality display		Position of vertical
	Measurement progress indicator		Position of sensor on the vertical (actual value)
	Water temperature		Position of sensor on the vertical (set value)
	Battery power supply		Depth of the sensor (actual value)
	Flow velocity		Note: Leave sensor at current position (depth)
	No signal (blinks)		Note: Position sensor further up/down

4.2.3 Operating keys

With the help of the operating keys (◆, ●, ■), you can control the menu sequence or delete existing characters in the input masks. The function of the operating keys depends on the current operating situation. It is shown directly above the respective key in the display.

	Call main menu		Return to previous menu
	Ok and continue		Delete character (in entry masks)
	Delete or cancel		Confirm entry (in input masks)
	Move up/down (in multipart menus and lists)		Call help
	Switch between two views on a display		Starting measurement

4.2.4 Character entry

Characters, e.g. file names, are entered in special input masks via the keyboard of the handheld unit. Depending on the operational situation, the entry of numbers (numerical values) or text (alphanumeric values) is possible in the individual entry mask.

- Numerical values, ". " and "-": press relevant key once.
- Alphanumeric values: press relevant key 1x, 2x, 3x or 4x until the required character is shown in the display.

Fig. 6: Example of an input mask: entering file name

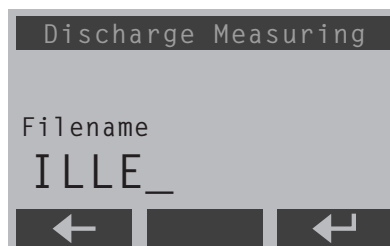

4.2.5 Interfaces and switches on the handheld unit

On the underside of the handheld unit there is a socket for the sensor connection, the on/off switch, and the USB connection to the PC.

Fig. 7: Interfaces and on/off switch on handheld unit

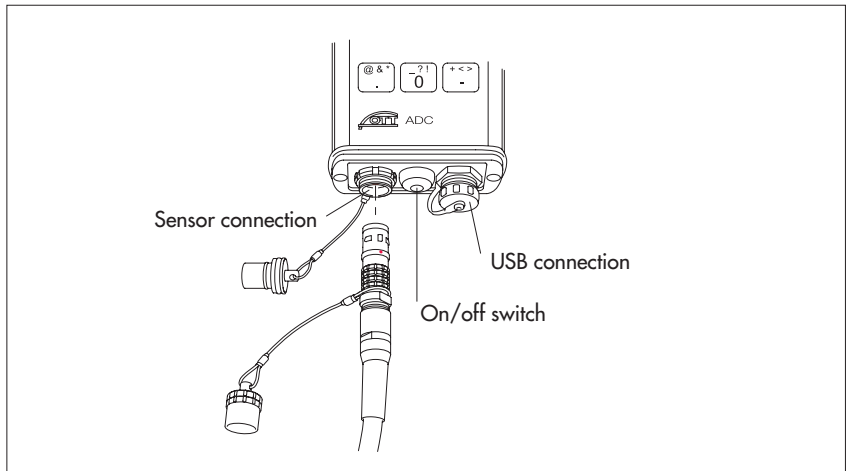

Please note

Cover the socket and the USB connection as soon as they are no longer needed for connecting to the sensor or the PC. For this use the protective covers supplied. The sealing of the handheld unit is only ensured in this way and the interfaces are also protected against dust and corrosion.

5 Starting up the OTT ADC

Before you can carry out a measurement with the OTT ADC, you have to prepare the unit for the measuring process. This includes:

- ▶ Ensuring the power supply
- ▶ Setting the handheld unit according to requirements
- ▶ Attaching the sensor to the measuring rod
- ▶ Attaching the handheld unit to the measuring rod
- ▶ Connecting the sensor to the handheld unit

5.1 Ensuring power supply

The power supply for the handheld unit and sensor is provided by rechargeable batteries, which are permanently installed in the handheld unit. The charging state of the battery is shown by the filled amount of the battery symbol in the upper right corner of the display. You can also query the charging state via the menu of the handheld unit.

See menu

Main menu [2/2]/System Status/Battery

With fully charged batteries, operation for more than 20 hours measuring operation is possible. Empty batteries can be charged more than 500 times. The charging time with completely discharged batteries is approx. 2 hours.

The handheld unit is equipped with intelligent energy management. A switched on device supplied by the batteries switches off automatically if no keys are pressed or no data communication takes place over a period of more than 15 minutes. The background illumination is switched off as standard after 30 seconds without a key press. However, the automatic switching off of the background illumination can also be deactivated.

All data saved on the handheld unit are persistent and are also retained even with completely discharged batteries.

Please note

Replacing the batteries installed is only possible by the OTT repair center (see Appendix E "Repair").

Charging batteries

- ▶ Required components: handheld unit, power supply with charging cable connector and power supply cable with plug, charging cable.

How to charge the batteries

- Connect the charging cable connector of the power supply to the charging cable with the barrel connector.
 - Connect the charging cable to the handheld unit via the USB connection.
 - Connect the mains plug of the power supply to the mains electricity supply.
- The batteries are charged. The display of the handheld unit is automatically switched on. The charging process lasts around 2 hours.

It is possible to make entries via the handheld unit while it is being charged.

Note

You can also charge the batteries using a vehicle voltage converter. There is an optional adapter available for this (see Chapter 14 "Order numbers and accessories").

Caution

The power supply has been specially developed for the OTT ADC. The power supply may not be used for other devices that correspond to the USB standard, as differences in the output voltage can lead to damage to the device!

5.2 Starting up the handheld unit

Before you start using the handheld unit, ensure that the batteries are charged.

Switching the handheld unit on/off

■ Press on/off switch for approx. one second.

The startup process takes approx. 10 seconds. It is finished when the "++++" at the upper edge of the display disappears.

5.2.1 Setting the handheld unit

You can adapt the settings of the handheld unit according to your individual wishes. Menus that contain the parameters for individual settings can be found in the main menu.

See menu

Main Menu [2/2]

The following menus are relevant:

▶ *System Settings/System Menu*

Here you can set the date and time, control the display screen, and change the volume for key and feedback sounds.

▶ *Advanced/Advanced*

Here you can set the display language, specify whether the key sounds are switched on and specify the unit of measurement to be used on the display and for calculations (*metric/imperial*).

Further information on the individual parameters and options of the relevant menus can be found in Chapter 7 "Menu functions on the handheld unit".

5.2.2 Attaching the handheld unit to the measuring rod

The OTT ADC is supplied with a universal attachment for measuring rods. In this way the handheld unit can be attached both to rods with \varnothing 20 mm and to rods of type USGS.

There is a fixing plate on the rear of the handheld unit with a permanently attached ball head. When attaching the handheld unit to a rod, the aluminum plates of the universal attachment clamp onto the ball, thus allowing the handheld unit to move and be rotated in different directions.

Please note

Only attach the handheld unit after the sensor is mounted on the rod (see Chapter 5.3 "Starting up the sensor").

How to attach the handheld unit to the rod

- Clamp the aluminum plates of the universal attachment to the ball on the rear of the handheld unit.
- Loosen the wing nut.
- Clamp the free end of the universal attachment around the rod, so that the plastic coated plates surround the rod.
- Lock in the required position with the wing nut.

Fig. 8: Attachment of the handheld unit to the rod

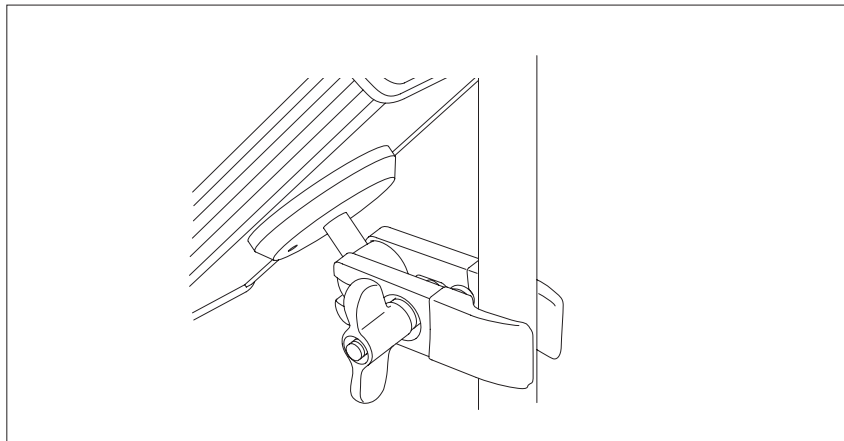

5.3 Starting up the sensor

Before beginning the measurement, you have to attach the sensor to the rod and connect to the handheld unit. The sensor end piece serves as a mechanical adapter for attaching the sensor to measuring rods.

5.3.1 Fixing and positioning the sensor on the 20 mm diameter rod

- ▶ Required components: OTT ADC sensor, 20 mm diameter rod (starting piece), extension for rod if necessary

How to attach the sensor to the rod

- Unscrew the fixing sleeve of the sensor end piece.
- Push the sensor with the circular hole of the sensor end piece (mechanical adapter) over the rod. Ensure the sensor connection cable is pointing upward.
- Position the sensor at the required point on the rod.
- Tighten the fixing sleeve of the sensor end piece until the sensor is fixed.
- Extend the rod as required.

Fig. 9: Attachment of the ADC sensor to the rod

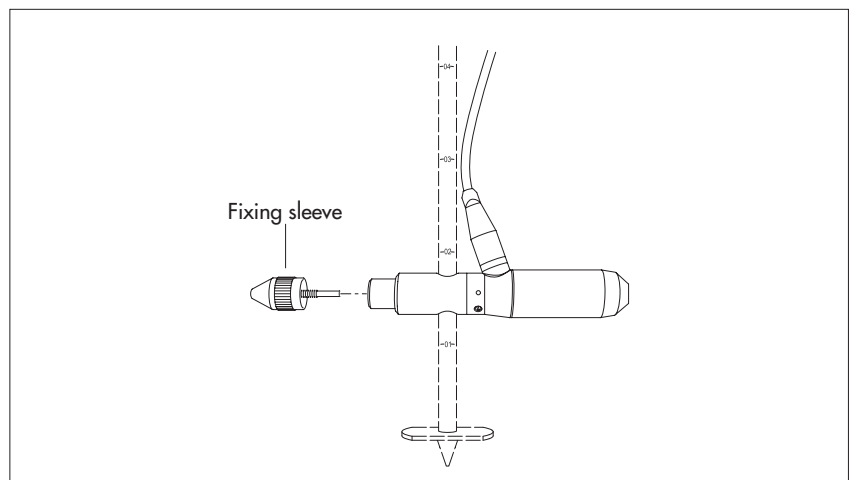

How to position the sensor on the rod

To move the sensor to a different position on the rod during a measurement, it has to be lifted out of the water.

- Unscrew the fixing sleeve of the sensor end piece.
- Move the sensor and fix at the new position with the fixing sleeve.

5.3.2 Fixing and positioning the sensor on the rod with the OTT HERES top setting wading rod

When using the OTT HERES top setting wading rod, the sensor is attached to the top setting wading rod using the HERES adapter.

- ▶ Required components: OTT ADC sensor, OTT HERES top setting wading rod (starting piece), 20 mm diameter rod, extension for rod and OTT HERES if necessary

How to attach the sensor to the OTT HERES

- Unscrew the fixing sleeve off the sensor end piece.
- Loosen the Allen screw on the HERES adapter.
- Push the sensor end piece onto the receiver provided on the HERES adapter and fix with the Allen screw. Ensure the sensor connection cable is pointing upward, towards the rod.
- Slide the starting piece of the OTT HERES onto the rod with the sensor mounted.
- Extend the rod and OTT HERES as required.

Fig. 10: Attachment of the ADC sensor to the OTT HERES

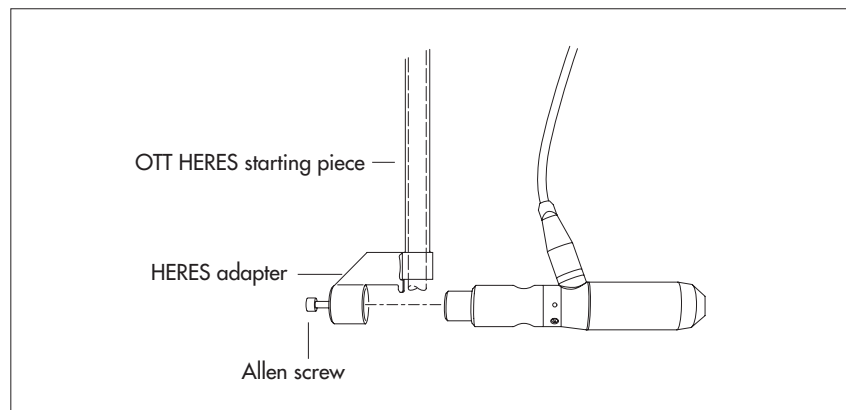

How to position the sensor with the OTT HERES

Using the OTT HERES top setting wading rod, which is pushed over the rod as a sleeve, the sensor can be repositioned without lifting it out of the water.

- Loosen the fixing screw of the OTT HERES top setting wading rod.
- Move the sensor with the OTT HERES and fix at the new position with the fixing screw.

5.3.3 Fixing and positioning the sensor to rods of type USGS

- ▶ Required components: OTT ADC sensor with sensor end piece as mechanical adapter for rod type USGS, rod of type USGS with appropriate meter/sensor bracket, extensions for rod if necessary

How to attach the sensor to the USGS rod

- Push the sensor with the circular cutout of the sensor end piece (mechanical adapter) onto the receiver provided on the meter/sensor bracket of the rod. Ensure the sensor connection cable is pointing upward.
- Press the sensor as far as it goes.
- Fix the sensor with the fixing screw of the mechanical adapter.
- Position the sensor at the required point on the rod (see below).
- Extend the rod as required.

Fig. 11: Attachment of the ADC sensor to rods of type USGS

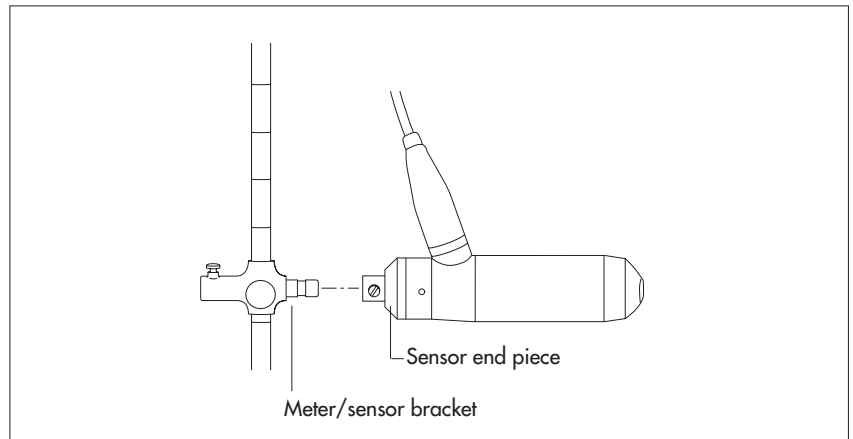

How to position the sensor on the USGS rod

- Loosen the fixing screw of the meter/sensor bracket.
- Move the sensor and fix at the new position with the fixing screw.

5.3.4 Fixing and positioning the sensor to rods with USGS top setting wading rod

- ▶ Required components: OTT ADC sensor with sensor end piece as mechanical adapter for rod type USGS, top setting wading rod of type USGS with appropriate meter/sensor bracket, extensions for round rod and top setting wading rod if necessary

How to attach the sensor to the USGS top setting wading rod

- Push the sensor with the circular cutout of the sensor end piece (mechanical adapter) onto the receiver provided on the meter/sensor bracket of the top setting wading rod. Ensure the sensor connection cable is pointing upward.
- Press the sensor as far as it goes.
- Fix the sensor with the fixing screw of the mechanical adapter.
- Position the sensor at the required point on the round rod (see below).
- Extend the USGS top setting wading rod as required.

Fig. 12: Attachment of the ADC sensor to the USGS top setting wading rod

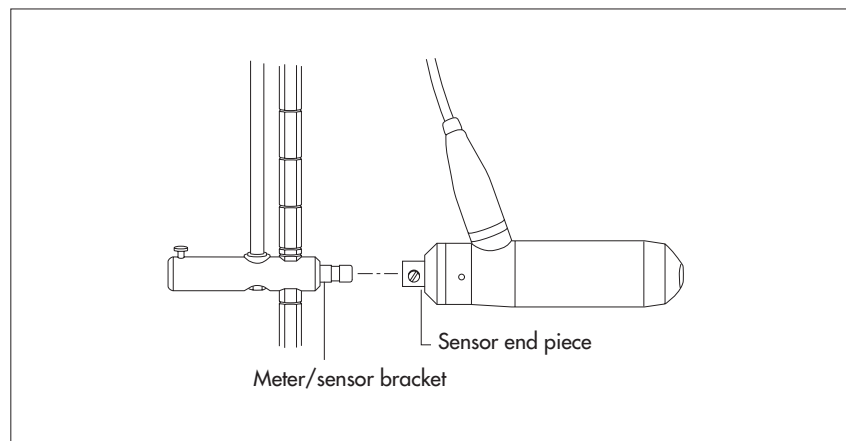

How to position the sensor with the USGS top setting wading rod

- Press on the rubber stopper of the catch on the handle of the USGS top setting wading rod and release the catch.
- Move the sensor using the round rod and hold at new position.
- Release pressure on the rubber stopper and lock.

5.4 Connecting the sensor to the handheld unit

To provide the sensor with electricity and allow communication with the handheld unit, it has to be connected to the handheld unit.

- Remove the protective cover from the plug of the sensor connection cable and from the sensor connection socket of the handheld unit.
- Connect the sensor connection cable to the handheld unit. Take care to note the red markings on the plug and socket!

After switching on the handheld unit, the OTT ADC is ready for measuring (see Chapter 6.2 "Carrying out measurement").

6. Preparing and carrying out discharge measurement

The following sections describe what you have to take note of before a discharge measurement with the OTT ADC and in which steps the actual measurement proceeds.

Explanations for the individual menus and sub menus can be found in Chapter 7 "Menu functions on the handheld unit". The brief instructions for the ADC show step-by-step with example illustrations how to use the OTT ADC menus during a discharge measurement.

6.1 Preparing for measurement

6.1.1 Checking the measuring equipment

Before going to the station, you should collect the measuring equipment required and check its functionality.

Note the following points:

- ▶ All components of the OTT ADC must be in perfect condition and be complete in the transport case.
- ▶ The handheld unit must have sufficient battery capacity (see Chapter 5.1 "Ensuring power supply").
- ▶ Handheld unit and sensor must have the same serial number – important if there are several OTT ADC devices available.
- ▶ Measuring rods and top setting wading rods to be used must be available in sufficient number and be able to be connected without problem.
- ▶ Aids for setting up the station must be ready, e.g. measuring rope or tape measure, pegs, sledge hammer, sickle, etc.
- ▶ Functional protective clothing should be available (waders, rubber boots, waterproof clothing, etc.).

6.1.2 Setting up the station

The area of use of the OTT ADC attached to the rod is limited by the effort needed from the user to hold the sensor against the pressure of the flow. The effort is mainly dependent on the flow velocity of the waterway and the length of the lever.

Setting up the measurement cross-section

The correct selection of the measurement cross-section is significant for the quality of the measurement. Hydraulically suitable stations can be found in a straight length of waterway with regular cross-sections and as consistent a bed gradient as possible. Measurement cross-sections with still areas, counter or eddy currents should be avoided. Equally unsuitable are stations in deep pools, below large inflows, in the vicinity of ship moorings, ferries and sluices.

The measurement cross-section is set at right angles to the main flow direction. For this a tape measure or a measuring rope is used, for example. Ensure that the tape or measuring rope is taut.

Specify the verticals

The number and position of the verticals are dependent on the geometric shape of the measurement cross-section and the intended measurement and evaluation method. The following rules apply according to EN – ISO 748:

Tab. 1: Number of verticals in relation to the waterway width

Waterway width in m	Number of verticals
> 0 and < 0,5	3 – 4
> 0,5 and < 1	4 – 5
> 1 and < 3	5 – 8
> 3 and < 5	8 – 10
> 5 and < 10	10 – 20
> 10	> 20

The distances between verticals are generally smaller where water depth and flow velocities change significantly. This affects above all the bank areas, vertical or steep slopes, ledges in divided cross-sections and transitions from the main waterway bed to the foreland. Verticals should also be located at significant changes in the profile of the waterway bed. With consistent bed gradient of the waterway there is the possibility to reduce the number of verticals and to space them evenly without being in conflict with the above requirements.

European standard EN ISO 748 recommends selecting verticals in such a way that with large waterways a discharge segment defined by the vertical(s) represents less than 5% of the complete discharge where possible and a maximum of 10%. A sufficient number of verticals is thus a prerequisite.

With discharge measuring with the OTT ADC you can check the percentage proportion of the complete discharge for each segment: This is automatically calculated and shown on the display of the handheld unit at the end of the measurement.

See menu

Main menu [1/2]/Discharge Measuring/Start/.../Completed/Discharge Measuring/Details

6.2 Carrying out measurement

Requirements: The measuring equipment is complete and functioning, the station is set up, sensor and, as required, handheld unit are attached to the rod, the sensor is connected to the handheld unit.

6.2.1 Depth calibration

To determine the water and sensor depths, an absolute pressure cell is built into the sensor body of the OTT ADC. To ensure correct measurement values, the pressure cell must be calibrated under the currently existing air pressure conditions.

Please note

The sensor must be outside the water during calibration.

A first calibration is started before beginning the measurement with the help of the handheld unit. During the measurement, you are requested every 30 minutes to repeat the calibration via the user interface of the handheld unit.

See menu

Main Menu [1/2]/Depth Calibration

6.2.2 Making basic settings to the discharge measurement

In order to lead the user through the discharge measurement, and for the subsequent determination of the discharge, the OTT ADC firstly needs basic data for the respective station. These data (basic settings) are entered via the handheld unit before beginning the measurement.

The following basic settings are necessary for each measurement:

- ▶ Details for near edge and far edge, such as position, water depth, roughness and stream width
- ▶ Position of the first vertical and spacing of the verticals
- ▶ Planned sequence of the measurements at the verticals (e.g. from bottom to top)
- ▶ Rod offsets (distances between rod base plate and waterway bed and between base plate and symmetry axis of the sensor)
- ▶ Method of velocity measurement (e.g. 2-point method or multi-point measurement)
- ▶ Selection of the discharge calculation method (MID or MEAN section)
- ▶ Required measurement duration per measure point
- ▶ If necessary, details of salt content of the water

If basic settings already exist for the station concerned, these can be loaded and used again. It is also possible to load the data for a measurement already carried out and saved and to add further measure points.

See menu

Main menu [1/2]/Discharge Measuring/Settings/...

The measurement should also be named. For this the following details are required:

- ▶ File name to be used for saving the measurement data
- ▶ Name of the party

See menu

Main menu [1/2]/Discharge Measuring/Name or Party

6.2.3 Carrying out discharge measurement

The sensor is only put into the water at the beginning of the discharge measurement. The depth of the sensor must be at least 2 cm.

The sensor is ideally positioned when the sensor head is pointing against the direction of flow and the symmetry axis of the sensor is at right angles to the measurement cross-section. There should be no obstructions in the immediate vicinity of the sensor. Ideally, the measurement is carried out from a bridge or a measuring pontoon. If the measurement is taken directly in the water, the user must stand at a sufficient distance from the measuring device to ensure an unobstructed flow.

Fig. 13: Positioning of the OTT ADC sensor in the water



How to carry out a discharge measurement

- Position the sensor at the first vertical.
- Call the *Discharge Measuring* menu and select *Start*.
- In sub menu *Start Measuring*, confirm the list of the important basic settings with *Ok* and *continue*.
- Lower the sensor to the bottom and select *Water Depth* in the window of the relevant measure point.
- In the subsequent window, confirm the measured water depth → return to the window for the relevant measure point.
- Select *Ok* and *continue* to call the measuring mode.
- Position the sensor at the first measure point. The correct depth is shown on the display of the handheld unit (the value *Submersion depth of sensor (set value)* blinks until the correct position is reached).
- Start measurement (press ● button).

The measurement now runs for the set time interval. After completing the measurement, the result for this measure point is displayed. You can reject the measurement and repeat it, or confirm it and continue with the next measure point. Once the measure points for all verticals have been processed, an appropriate message is shown. If necessary, you can modify the edge parameters retrospectively. Afterwards, the handheld unit shows the calculated complete discharge. If required, you can still call details of the partial discharges for the individual verticals and then end the measurement.

See menu

Discharge Measuring/Start...

Notes

- All relevant data for a discharge measurement are automatically saved on the handheld unit.
- You can interrupt a measurement already started. To do so, switch off the handheld unit. When next switched on, the measurement will be continued.

Please note

As soon as the point *Start* in the *Discharge Measuring* menu is selected, you are led through the measurement by the user interface of the handheld unit. Familiarize yourself with the display symbols so that you will correctly interpret the graphical information (see Chapter 4.2.2 "Display symbols").

Canceling measurement

A measurement already started can be canceled as soon as the operating key function for *Call Main Menu* is active in the respective operating situation.

- Call main menu and move to *Main Menu [1/2]* if necessary.
- Select menu point *Discharge*.
- Select *END*.

Navigate through the subsequent windows until the *Return* operating key function is active. Press several times as necessary on *Return* (operating key \blacklozenge), to reach rest mode.

6.3 Transferring data to the PC

The OTT QReview software is provided to clearly illustrate the data and for processing the data.

Using OTT QReview, the measurement data can be loaded onto the PC and processed further there (see Chapter 9 "Processing data with OTT QReview").

7. Menu functions on the handheld unit

If the sensor is out of the water, after switching on the handheld unit the display starts in rest mode after a few seconds unless a previous measurement had been interrupted. If the sensor is in the water, the display changes to measuring mode (see section "Measuring mode").

Fig. 14: Display in rest mode

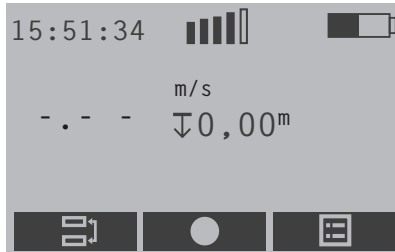

From the rest mode and, depending on the operating situation, from within certain menus and sub menus, the main menu is called with the right side operating key .

Note

The following description uses the unit "m" for clarity for displaying distances, depths, speeds and discharge values (e.g. m/s). If the appropriate setting is changed on the handheld unit, the values shown are displayed with the respective values in "ft".

7.1 Main menu

The main menu of the handheld unit is divided into two parts, *Main Menu [1/2]* and *Main Menu [2/2]*. Both parts include several menus that are also divided into sub menus and up to three subsequent windows. Menus, sub menus and subsequent windows are called by pressing the relevant number on the keyboard of the handheld unit. Some subsequent windows are accessed by using the operating keys.

Fig. 15: Part 1 and part 2 of the main menu

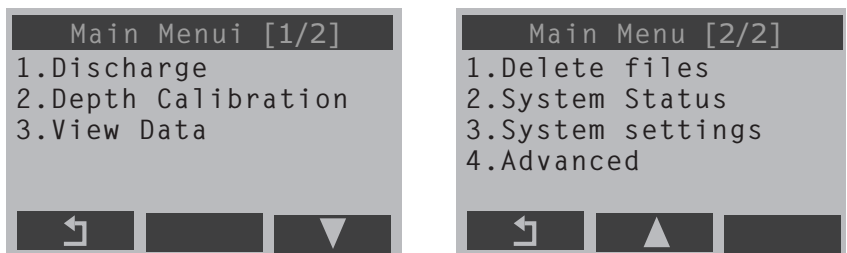

The following sections describe the individual menus and their sub menus and subsequent windows. A detailed view of the most important display views can be found in the brief instructions. For an overview of the main menu see „Appendix H“.

7.2 Discharge measuring menu

In this menu the basic settings are made for a discharge measurement and the measurement is started.

- ▶ Settings Making basic settings for the measurement. The basic settings are used as input parameters for internal advance planning of measurements and for calculating partial flows and complete discharge.
- ▶ Name Enter the file name for the measurement.
Input format: alphanumeric, max. 8 characters
- ▶ Party Enter the name of the party.
Input format: alphanumeric, max. 30 characters
- ▶ Notes Enter notes.
Input format: alphanumeric, max. 80 characters
- ▶ START Start discharge measuring.

Sub menu Discharge Measuring/Settings

This sub menu is divided into three subsequent windows in which you enter parameters for the measurement cross-section, the type of measurement and the calculation method. The measurement time is also specified and the salinity of the waterway if appropriate.

Subsequent window Discharge Measuring /Settings/Discharge [1/3]

- ▶ Load... Load basic settings from a saved file and use it, or continue previous measurement.

Subsequent window Discharge Measuring /Settings/Discharge [1/3]/Load...
 - ▶ Load settings only Calls the list of saved files. After selecting the file required, the settings saved there are loaded. They are now preset for the new measurement and can be modified as necessary.
 - ▶ Continue a previous measurement Calls the list of saved files. After selecting the required file, the settings saved there are loaded and the relevant measurement can have further measure points added.
- Note**
To go to the measuring mode, after selecting the required file press *Return* three times (key **◆**). Vertical and position of the next measure point are shown on the display.

▶ Near edge
Enter parameters for the near edge.
The near and far edges are the left and right edge points that limit and define the complete width of the water surface. The near edge is on the side where the measurement is started from.

Subsequent window Discharge Measuring /Settings/Discharge [1/3] /Near Edge

- ▶ Position
Position of the near edge (m).
Value = 0 if the near edge corresponds to the reference point for calculating the position of the verticals. As a rule, the reference point is the cross-section zero point of a measured discharge cross-section.
Value > 0 if the near edge is not the reference point. The value is then equal to the distance of the near edge from the reference point.
Value Range: 0.00 - 300.00
Entry format: numerical
- ▶ Depth
Water depth at the near edge (m).
Value = 0 for natural waterways
Value > 0 for right-angled cross-sections
Value range: 0.00 - 10.00
Entry format: numerical
- ▶ Roughness
Roughness factor of the side wall.
The roughness factor is only relevant for right-angled cross-sections. For these, it is used as an influencing factor when calculating the discharge proportion of the edge areas.
Value range: 0.00 - 1.00
0.00 = very rough; 1.00 = smooth
Entry format: numerical
- ▶ Stream width
Width of the water surface from the left to the right edge (m).
Corresponds to the value for *stream width* in subsequent window *Far Edge* and is automatically adapted there if the stream width is changed here.
Value range: > 0.00 - 300.00
Entry format: numerical

Note

The values for position near/far edge and stream width are dependent on each other. If the value for position is changed to a value > 0, a value previously set for stream width is automatically adapted to this value.

- ▶ Far Edge Enter parameters for the far edge.
For definition see "Near Edge"
The far edge is on the side where the measurement is ended.
- Subsequent window Discharge Measuring /Settings/Discharge [1/3]/Far Edge
- ▶ Position Position of the far edge (m).
Value > 0
The value is equal to the distance of the far edge from the reference point.
Value range: > 0.00 - 300.00
Entry format: numerical
- ▶ Depth Water depth at the far edge (m).
Value = 0 for natural waterways
Value > 0 for right-angled cross-sections
Value range: 0.00 - 10.00
Entry format: numerical
- ▶ Roughness Roughness factor of the side wall.
The roughness factor is only relevant for right-angled cross-sections. For these, it is used as an influencing factor when calculating the discharge proportion of the edge areas.
Value range: 0.00 - 1.00
0.00 = very rough; 1.00 = smooth
Entry format: numerical
- ▶ Stream width Width of the water surface from the left to the right edge (m).
Corresponds to the value for *stream width* in subsequent window *Near Edge* and is automatically adapted there if the stream width is changed here.

Note

If required, the edge parameters can be changed retrospectively at the end of a measurement.

- ▶ Verticals

Enter position and spacing of the verticals and the measurement sequence.

Subsequent window Discharge Measuring /Settings/Discharge [1/3]/Verticals

 - ▶ First pos.

Distance of the first vertical from the reference point (m).
Value range: 0.00 - 300.00
Entry format: numerical
 - ▶ Spacing

Distance between the verticals (m).
Value range: 0.00-10.00
Entry format: numerical

Note
The value for *Spacing* should be > 0 so that the OTT ADC can calculate the position of the individual verticals in advance.
 - ▶ Measure Order

Sequence in which the measure points are processed along the verticals. The current setting is shown on the display.
In the subsequent window the measurement sequences *Surface to bottom*, *Bottom to surface* and *Alternating* are available.
- ▶ Rod Offsets

Distances between sensor/base plate and base plate/waterway bed.
The symmetry axis of the sensor – where the pressure cell is located – never lies directly on the waterway bed and there is therefore a remaining distance. When using rods with base plate and tip, this extra distance can be larger, depending on whether the subsurface is firm or yields. The extra distance is important as a parameter for the correct determination of the water depth.

Subsequent window Discharge Measuring /Settings/Discharge [1/3]/Rod Offsets

 - ▶ Sensor offset

Distance between the symmetry axis of the sensor and the base plate of the rod (m).
Value Range: 0.00 - 1.00
Entry format: numerical
 - ▶ Point offset

Distance between the base plate of the rod and the waterway bed (m).
Value range: 0.00 - 0.50
Entry format: numerical

Subsequent window Discharge Measuring /Settings/Discharge [2/3]

▶ Measure method

Methods for velocity measurement.

The currently selected method is shown on the display.

In the subsequent window there are 11 methods available: 1-point, 2-point, 3-point, 4-point, 5-point, 6-point measurement, 2-point Kreps method (*2 Point Kreps*), 1-point ice measurement (*Ice, Single point*), 2-point ice measurement (*Ice, Two Point*), surface 1-point measurement (*ISO, surface*), multipoint measurement. Explanations of the individual methods for velocity measurement can be found in Appendix A.1 "Overview: Methods for velocity measurement".

▶ Using

Set the method for calculating the complete discharge. The currently set method is shown on the display.

The possibilities available are *MID-section* or *MEAN-section*.

Note

Experience shows that the MID section method provides more exact results (ISO 748).

▶ Corr.factor

Correction factor for the 1-point ice measurement and the surface 1-point measurement.

Can only be selected if under *Measure method* the *Ice, Single point* or *ISO, surface* method has been selected.

Value range: 0.7-1.0

Entry format: numerical

Subsequent window Discharge Measuring /Settings/Discharge [3/3]

- ▶ Averaging
 - Enter measuring time (s).
 - The measuring time applies to all measure points.
 - The currently set measuring time is shown on the display.
 - Value range: 1-480
 - Entry format: numerical, integer
 - Note**
 - The length of the measuring time at a measure point should be at least 30 s. It is generally set at between 30 s and 50 s.

- ▶ Salinity
 - Enter salinity (ppt).
 - The currently set value is shown on the display.
 - The salinity influences the speed of the sound and is used as a parameter in the velocity measurement. In freshwater waterways, this is generally 0 ppt.
 - Value range 0-50
 - Input format: numerical, integer

Sub menu Discharge Measuring/START

In this sub menu the discharge measurement takes place. If no name has been given in the basic settings, the file name for the measurement is queried after calling *START*. The following two windows list the previously made basic settings for information purposes:

The *Start measuring* window shows the file name of the measurement, the waterway width, the total number of verticals and the number of measure points. After confirmation, the subsequent window *Point #i* is displayed.

The *Discharge-Details* window shows the selected measuring method and calculation method.

Subsequent window Discharge/START/Start Measuring/Point #i

With this window you can run the measurement of the water depth at the verticals. The window also provides information on the position of the verticals and the selected measuring method, which can also be modified as required. Finally, you can end the measurement at the respective vertical.

- ▶ Vertical Number of the vertical. The first vertical has the number 1.
- ▶ Position Distance of the vertical from the reference point (m).
The position can be modified in the following input window.
Value range: 0.00 to 300.00
Input format: numerical
- ▶ Water Depth Water depth at the vertical (m).
To measure the water depth, the user lowers the sensor to the bottom and calls menu point *Water Depth* (key 2).

Subsequent window Discharge/START/Start Measuring/Point #i/Water Depth

Measured:

- ▶ Sensor Depth Depth of the sensor (m)
- ▶ Sensor offset Distance between the symmetry axis of the sensor and the waterway bed (m).
The distance shown is dependent on the basic settings for the rod offset, which are listed in the subsequent window and can be modified if necessary (see also subsequent window *Discharge/Settings/Discharge [1/3] /Rod Offsets*).
- ▶ Water Depth The water depth calculated from the sensor depth and sensor offset (m).
In the subsequent window it is possible to modify the calculated water depth.
Value range: 0.0 - 10.0
Entry format: numerical
- ▶ 2-point (example) Currently set method for velocity measurement. The method can be modified in the *Measure method* subsequent window.
- ▶ End this vertical End measurements for this vertical and continue with the next vertical.

Notes

- The measurement of the water depth is necessary at every vertical. It can also be carried out in the detail window *Vertical i* or *Next vertical [i]*.
- If you modify the position of a vertical, the OTT ADC calculates the positions of the following verticals based on this new position.

Detail window Discharge/START/Start Measuring/Point #i/Vertical [i]

This window summarizes the information on the respective vertical. If required, the values displayed can be modified, the current water level entered and measurements of any obstructions entered.

▶ Position	Distance of the vertical <i>i</i> from the reference point (m). The position can be modified in the subsequent entry window. Value Range: 0.00 - 300.00 Entry format: numerical
▶ Depth	Water depth at the vertical (m). The current value can be confirmed or modified in the subsequent window (see subsequent window <i>Discharge/START/Start Measuring/Point #i/Water depth</i>).
▶ Gauge	Current gauge level (m). The gauge level can be entered/changed in the subsequent entry window. Entry format: numerical
▶ Define obstruction	Enter definition of any obstructions in the measurement cross-section. An obstruction is, for example, a bridge pier.
Subsequent window Discharge Measuring/START... /Vertical [i] /Define obstruction	
▶ First edge	Distance of the side of the obstruction facing the near edge from the reference point (m). Value Range: 0.00 - <i>Stream width</i> Entry format: numerical
▶ Last edge	Distance of the side of the obstruction facing the far edge from the reference point (m). Value Range: 0.00 - <i>Stream width</i> Entry format: numerical
▶ Width	Width of the obstruction (m). Value range: 0.00 - 300 Entry format: numerical Is automatically calculated if the edge values are already available.

Note

If an obstruction is defined, the OTT ADC recalculates the position of the respective verticals.

Measuring mode

After you have confirmed the window *Point #i* with **Ok** and continue, the handheld unit changes to measuring mode. Position the sensor at the preset depth. Take note of the display symbols – the OTT ADC shows the depth of the relevant measuring point and whether the sensor is already at the correct position (see Chapter 4.2.1 "Display screen"). Alternatively, you can change the display view to call further information, e.g. on water temperature and SNR value (measure of the validity of the measured values - see Chapter 8.4 "Internal quality check").

Fig. 16: Example for alternative displays during the measurement

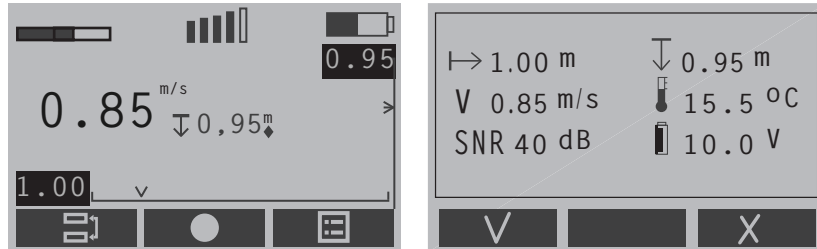

Start the measurement with key **●**. The measurement runs for the set amount of time. At the end of the measurement, the results are shown in a subsequent window. You can reject this measurement and repeat it, or accept the measurement results and continue with the next measure point. Once all measure points for a vertical have been processed, the subsequent screen *Completed* is shown.

Note

If the sensor is not positioned at the specified measure point, you receive the warning message "Wrong depth" after starting the measurement. If you still want to position the sensor at a depth other than that specified, continue as follows:

- Cancel the warning message (key **■**).
- In the subsequent entry window, enter the required depth.
(input format numerical, value range 0.0 - 10.0)
- Continue the measurement.

Subsequent window *Discharge/START/Start Measuring/Point #i/.../Completed*

The measurement is completed for all measure points of a vertical. You can confirm the information in this window and continue with the next vertical, or you can reject the measurement for this vertical.

- | | |
|-------------------------|--|
| ▶ Vertical nr. <i>i</i> | Number of the respective vertical. |
| ▶ Position | Distance of the vertical from the reference point (m). |
| ▶ Avg. Velocity | Average flow velocity at the vertical (m/s). |
| ▶ Points | Number of measure points that have been measured. |

Subsequent window Discharge Measuring/ START.../Completed/ Next vertical [i]

This window shows the position of the next vertical. Here you can also measure the water depth, enter the new gauge, and define any obstructions. The parameters in this window are identical to the parameters in the detail window *Vertical i*.

See menu

Discharge/START/Start Measuring/Point #i/Vertical [i]

After you have confirmed the window *Next vertical [i]*, the window for the next measure point is displayed. This has the identical content to window *Point #1* of the first measure point.

See menu

Discharge/START/Start Measuring/Point #i

After confirming with OK and continue, the measurement for this measure point is started.

When the measure points of all verticals have been processed, you receive the message *DISCHARGE MEASUREMENT COMPLETED*. This is followed by the window for setting the edge parameters in which you can change these parameters if necessary. This can be particularly necessary for the far edge parameters as they may only be clearly ascertained at the end of the measurement.

See menu

Discharge Measuring /Settings/Discharge [1/3]/Near Edge or Far Edge

Subsequent window Discharge Measuring/START.../Completed/ Next vertical/.../Completed/Edges/Discharge Measurement

▶ Name	File name of the discharge measurement.
▶ Discharge	Calculated total discharge (m ³ /s).
▶ Details	Details of the discharge measurement.
Subsequent window <i>File name</i>	
▶ Discharge	Calculated total discharge (m ³ /s).
▶ Avg. Velocity	Average flow velocity (m/s).
▶ Avg. Depth	Average water depth (m).
▶ Area	Size of the measurement cross-section (m ²).

Scrolling with the operating keys ● and ■ opens the detail windows for the individual verticals:

Subsequent window *Vertical nr.i [x%]*

The percentage value (x%) shows what proportion of the total discharge is represented by the partial discharge of the vertical *i*.

▶ Position	Distance of the respective vertical from the reference point (m).
▶ Discharge	Partial discharge represented by vertical <i>i</i> (m ³ /s).
▶ Avg. Velocity	Average flow velocity at vertical <i>i</i> (m/s).
▶ Depth	Water depth at vertical <i>i</i> (m).
▶ Area	Cross-section of the measured discharge segment represented by vertical <i>i</i> (m ² /s).

7.4 View Data menu

Using this menu, you call the sub menu *Data Files*, which contains a list of all files saved on the handheld unit. The files contain information on discharge measurements previously carried out.

Subsequent window to sub menu View Data/Data Files

Shows the results of the complete discharge and partial discharges of the respective discharge measurement.

Subsequent window Data files/*filename*

▶ Discharge	Total discharge determined (m ³ /s).
▶ Avg. Velocity	Average flow velocity (m/s).
▶ Avg. Depth	Average water depth (m).
▶ Area	Size of the measurement cross-section (m ²).

Subsequent window Data Files/Vertical nr.*i* [x%]

Shows the results for each individual vertical. The percentage value (x%) shows what proportion of the total discharge is represented by the partial discharge of the vertical *i*.

▶ Position	Distance of the vertical <i>i</i> from the reference point (m).
▶ Discharge	Partial discharge represented by vertical <i>i</i> (m ³ /s).
▶ Avg. Velocity	Average flow velocity at vertical <i>i</i> (m/s).
▶ Depth	Water depth at vertical <i>i</i> (m).
▶ Area	Cross-section of the measured discharge segment represented by vertical <i>i</i> (m ² /s).

7.5 Delete files menu

Using this menu, you call the sub menu *Delete*, which contains a list of all files saved on the handheld unit. Here you can delete files that are no longer required. After selecting the files to be deleted, a warning is displayed. You can continue deleting or cancel the process.

7.6 System status menu

Using this menu you can call the *System Info* sub menu, which contains information on the handheld unit.

Sub menu System Status/System Info

- ▶ Free Memory Available memory, relative (in %) and absolute (in points).
- ▶ Battery Charging state of the battery in %.
- ▶ Serial Nr. Serial number of the handheld unit. Only a sensor with the same serial number may be connected to the handheld unit!
- ▶ Fw Firmware version. The firmware is a program permanently integrated in the handheld unit. An upgrade is possible with the OTT QReview processing software (see Appendix C "Firmware upgrade").

7.7 System settings menu

Use this menu to call the *System Menu* sub menu, in which you set the parameters for the handheld unit.

Sub menu System settings/System Menu

- ▶ Date and Time Setting date and time.
- ▶ Display Set display and measured value display.
- ▶ Sound level Set volume.

Subsequent window System Settings/System Menu/Date & Time

Input mask for time and date.

The date entry format is numerical and integer in each case.

- ▶ Hour Current time: Enter whole hours.
Value range: 0-24
- ▶ Minutes Current time: Enter minutes.
Value range: 0-60
- ▶ Seconds Current time: Enter seconds.
Value Range: 0-60
- ▶ Day Current date: Enter day.
Value range: 1-31
- ▶ Month Current date: Enter month.
Value range: 1-12
- ▶ Year Current date: Enter year.
Value range: 0-99
e.g. 08 for the year 2008.

After confirming with *Ok* and *continue*, your entries are displayed. After renewed confirmation, the date and time are saved in the handheld unit.

Example for output

14:22:32

13/11/08

Subsequent window System Settings/System Menu/Display

- ▶ Backlight Set display illumination on/off
Subsequent window... /Display | Backlight
The current setting is marked with **
 - ▶ On The display remains illuminated until the hand-held unit is switched off.
 - ▶ Automatic The illumination is automatically switched off if after approx. 30 seconds no entry has been made or no data communication has taken place.
 - ▶ Off The display illumination is switched off.
- ▶ Contrast Setting the display contrast.
Value Range: 1-10
(1 = low contrast, 10 = high contrast)
- ▶ Velocity display Specify the frequency of the measured value display.
Subsequent window... /Velocity display
The current setting is marked with **
 - ▶ Continuous The measurement results for flow velocity measurement are continuously displayed and updated every second.
Note
The continuous display allows a visual impression of the turbulence of the flowing waterway.
 - ▶ Result only Only the end result of the flow velocity measurement is displayed.

Subsequent window System Settings/System Menu/Sound level

- ▶ Sound level Sets the volume for key clicks and feedback sounds.
Value Range: 0-10
(0 = no sound, 10 = loud)

7.8 Advanced menu

Use this menu to call the *Advanced* sub menu, where you can make further settings for the handheld unit, clear the memory, or carry out a reset.

Sub menu *Advanced/Advanced*

- | | |
|-------------------|--|
| ▶ Language | Select display language. |
| ▶ Key Sound | Switch key sounds on/off. The current setting is shown on the display ([ON] or [OFF]). |
| ▶ Units | Select units. |
| ▶ Format Recorder | Format recorder.
After calling <i>Format Recorder</i> a warning message appears. After confirming the message, all files saved on the handheld unit are deleted. |
| ▶ Reset | Carry out reset.
After calling <i>Reset</i> a warning message appears. After confirming the message, all settings on the handheld unit are deleted and reset to the settings at delivery. |

Subsequent window *Advanced/Advanced/Language*

Choice of English, Dutch, German, Spanish and French.
The currently set language is marked with **.

Subsequent window *Advanced/Advanced/Units*

The currently set unit is marked with **.

- | | |
|------------|--|
| ▶ Metric | Measured values and distances are calculated and displayed using the metric system. Unit: meter |
| ▶ Imperial | Measured values and distances are calculated and displayed using the imperial system. Unit: foot |

8. Ensuring data quality

To guarantee exact measurement data, an internal quality check in the device is necessary as well as correct use and active checking by the user.

Notes on the correct use of the OTT ADC can be found in the relevant sections of these instructions. The following sections describe what should be noted in addition to ensure the quality of your measured data.

8.1 Angle of flow

The angle of flow is the angle between the alignment of the sensor (symmetry axis) and the direction of flow. In an ideal situation, the angle of flow is 0° .

Hydraulically suitable stations exhibit low angles of flow when the sensor is positioned at right angles to the measurement cross-section and the flow is parallel to the edges.

Fig. 17: Sensor alignment with an angle of flow of 0° .

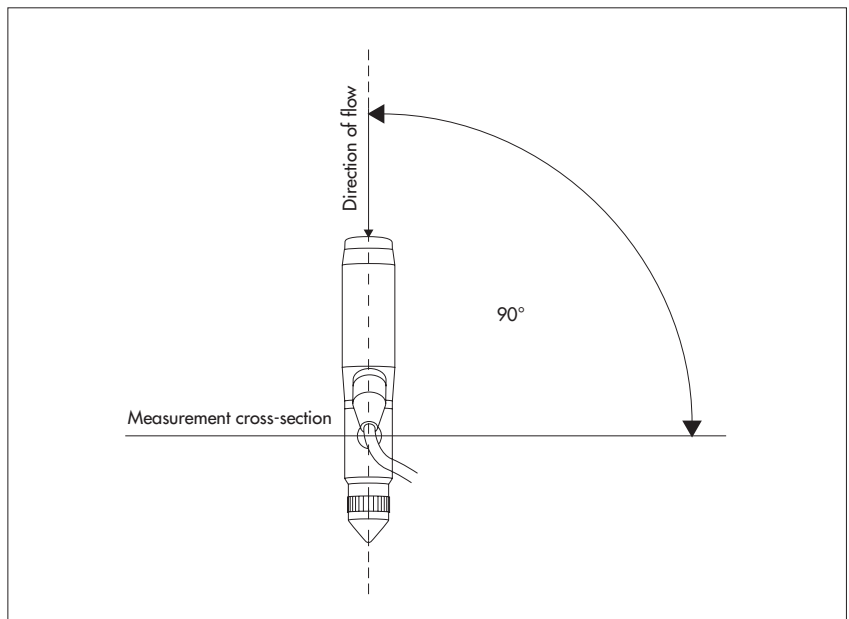

In practical use in the field, there are naturally often small deviations from the optimum sensor alignment leading to angled flows. These, but also angled flows resulting from the cross-sections (e.g. near to vertical edge walls), lead to angles of flow that are not equal to zero.

Due to the measuring principle and the location of the ultrasonic transducers, the OTT ADC is relatively little affected by angular flows. In field tests, the measurement of the velocity was found to be unaffected by angular flows of up to 10° . Furthermore, the measurement error is approx. 6 % with an angle of flow of 20° and approx. 8 % with an angle of 30° .

Please note

Align the sensor visually so that it is positioned towards the flow and at right angles to the measurement cross-section.

8.2 Temperature compensation

The OTT ADC is equipped with a temperature sensor. The water temperature is an important parameter both for the calculation of the speed of sound and for the temperature-compensated depth measurement with the pressure cell.

The temperature adjustment of the sensor under extreme conditions (from approx. 50° C to 5° C) takes approx. 5 to 6 minutes.

Please note

Before beginning the measurement, wait approx. 5 minutes until the sensor has adjusted to the temperature of the water.

8.3 Depth calibration

The OTT ADC is equipped with an absolute pressure cell. In order to be able to measure the depth of the sensor exactly, the pressure cell must be calibrated in the air before beginning the measurement (see Chapter 6.2.1 "Depth calibration"). An internal timer requests the user to recalibrate after 30 minutes. In this way, incorrect measurements caused by changes in air pressure are practically excluded.

8.4 Internal quality check

The internal quality check in the device is closely linked to the flow velocity measuring process. More details on this process can be found in Appendix B.

Each measured value is checked internally for adherence to the following criteria:

- ▶ Correlation > 40%
- ▶ Velocity > - 0.25 m/s and < 2.5 m/s
- ▶ Velocity gradient < 0.25 m/s
(difference between current measurement and the previously measured velocity)
- ▶ SNR > 10 db

Measured values that meet the criteria are saved. If the measurement time (integration time) is set to 30 s, for example, the OTT ADC collects a maximum of 30 values for each sound pulse. At the end of the measurement time, the OTT ADC checks whether at least 50% of all measured values are valid. If not, the measurement is rejected and the user requested to repeat the measurement.

If the measured values are confirmed, the OTT ADC calculates the mean and standard deviation for the measured velocities in the cells closest to and furthest from the sensor. Based on the result of the calculation, the final velocity is determined and output.

The focus of the internal quality check for flow velocity measurement is based on the parameters in the following table.

Tab. 2: Parameters for internal quality check

Parameters	Description	Comment
SNR	SNR (Signal-Noise Ratio) - Indicator for the strength of the reflections caused by the particles in the water - If the SNR value is too low, a valid measurement is not possible	Limit: SNR > 10 db
CF	CF (correlation factor) Indicator for the consistency of sequentially received scan patterns	Limit: CF > 40%
Peaks	Outliers in measured values caused by environmental conditions	see Comment A
σV	Standard deviation for the velocity - Indicator for the measurement accuracy - Takes account of water turbulence and internal measuring errors	see Comment B
% Q	Percentage proportion of a discharge segment to the total discharge	EN ISO 748:2000 %Q < 5% ideal %Q < 10% max. see Comment C

Comment A – peaks

Peaks are eliminated in the check of the velocity gradient.

Comment B – standard deviation

The standard deviation is decisive for the determination of the valid measuring range.

Comment C – segment proportion of total discharge

After a completed measurement, the percentage proportion of each segment of the total discharge is shown on the display of the handheld unit. The user can then decide whether additional verticals should be allocated.
(see recommendations in ISO standard).

Notes

- The SNR value can be viewed in the measuring mode by changing to the alternative display (see Chapter 7.2, Section "Measuring mode").
- The correlation is shown in the measuring mode with a display symbol (data quality display). Each solid, vertical bar represents a correlation factor of 20%. If all five bars are solid, the correlation is between 80% and 100%.
- The continuous display of the flow velocity on the handheld unit screen gives a visual impression of the waterway turbulence.

See menu

Main menu [2/2]/System Settings/System Menu/Display/Velocity display

9 Processing data with OTT QReview

To give a clear representation of your data on a PC and for subsequent analysis, the OTT QReview software is supplied. Using OTT QReview, you can transfer your measured data directly from the handheld unit to a PC.

9.1 System requirements

- IBM-compatible standard PC (notebook/desktop) from 233 MHz processor
- Operating system MS Windows 98 or higher
- 64 MB RAM
- 10 MB free space on hard drive
- Monitor with at least 800 x 600 pixel resolution (recommended \geq 768 pixel)
- USB connection

9.2 Installing USB device drivers and software

USB drivers for the handheld unit and the software components for OTT QReview can be found on the CD supplied.

- ▶ The drivers for the handheld unit are in the directory *PC Software/USB Driver*.
- ▶ OTT QReview components are in the directory *PC Software/QReview_xxx* (xxx = version identification).
Software updates can be found at **www.ott.com**.

9.2.1 How to install the drivers for the handheld unit

In order for the handheld unit to be recognized as a USB device, two components have to be installed on the PC:

- ▶ USB driver
- ▶ Serial driver (virtual COM port)

The following steps describe the driver installation using the automatic hardware recognition in Windows XP. The sequence of steps and window content can vary slightly for other Windows versions.

- Place the CD supplied in the CD drive of the PC.
- Connect the handheld unit to the PC via the USB connection. Use the USB cable supplied for this.
- Switch on the handheld unit.
The Add Hardware Wizard opens.
- In the *Welcome* window, answer the question whether a connection should be made to Windows Update with:
 - *No, not this time*Click on *Next*.

- In the next window, answer the question *How do you want to proceed?* with:
 - *Install software from a list or a particular source (for advanced users)*
 Click on *Next*.
- In the next window, select the following options:
 - *Search this source for the most suitable driver*
 - *Search (floppy disk/CD)*
 Click on *Next*.
- Ignore the subsequent warning message ... *Windows Logo Test not passed* and click on *Continue installation*.
The USB driver is installed.
- In the next window, click on *Finish* to complete the installation.

After successfully installing the USB driver, the Add Hardware Wizard is restarted as the serial driver for the USB device has not yet been installed. The installation of the serial driver is carried out in the same way. It starts with the *Welcome* window.

After installing both components, the handheld unit is available via the USB interface as an additional COM port for the PC.

Note

If the Add Hardware Wizard does not find a driver, it may be necessary to give the directory where the drivers are saved using *Browse...* . Depending on the processor type in the PC, various driver versions may be necessary for transmitting data from the handheld unit to the PC, which are saved in the following directories on the CD supplied:

- Directory *i386* for PCs with a Pentium processor
- Directory *amd64* for PCs with an AMD processor.

Checking the COM port

When transferring data from the handheld unit to the PC, or for a firmware upgrade, you may have to give the COM port the handheld unit uses to communicate with. The COM port can be found via the device manager of the operating system. For example, with Windows XP at:

*Start/Control Panel/System/Hardware/Device Manager/
Ports (COM and LPT)/OTT ADC (COMx)*

The COM port is only shown if the handheld unit is connected to the PC via the USB port and is switched on.

9.2.2 How to install the software

- Save QReview files from the relevant directory on the CD supplied onto the hard drive of the PC.
- Start the application: Double click on *QReview.exe*

9.3 Transferring data to the PC

Requirements:

- ▶ Software and drivers are installed. The COM port used for the handheld unit is known (see Chapter 9.2.1, Section "Checking the COM port").

How to transfer data to the PC

- Connect the handheld unit to the PC via the USB connection. Use the USB cable supplied for this.
- Switch on the handheld unit.
- Start the OTT QReview application (double-click on *QReview.exe*).
- Select *ADC* tab and click on *Connect*.
 - If necessary, check which COM port the handheld unit is available on.
 - In the subsequent window, select the relevant COM port from the drop-down menu and click on *Connect*.

The files are displayed in the the area *Files on ADC* in the *Connect* window. To save the files on the PC, proceed as described below:

- Highlight the files required.
- Under *Files on desktop*, select a directory where the files are to be stored.
- Click on the *Retrieve files* button.

The selected files are saved in the relevant directory on the PC. If no further files are to be saved, you can close the *Connect* window.

9.4 Processing and exporting data

In order to be able to process an ADC file saved on the PC with OTT QReview, you first have to open it:

- Select *File/open* in the main window of OTT QReview.
- In the subsequent window, select the required file from the relevant directory, mark it and confirm with *ok*.

In the *Graphics* tab, the measurement data for the selected file are shown graphically, and in the *Data* tab they are listed.

9.5 Menu functions in OTT QReview

You can edit the measured data, print it or export it. For this there are various menus available described briefly below. An exact description of the individual menu functions can be found in the online operating instructions for OTT QReview (*Help* menu).

- ▶ Using the *File* menu, open a new file or print out a file already open.
- ▶ In the *Edit* menu you can adapt the measurement data and recalculate it – e.g. you can change the calculation method.
- ▶ In the *Settings* menu you specify certain calculation parameters, e.g. a value that influences the calculation of the average flow velocity (*PowerLaw*) or the unit to be used.

In the *Settings* menu, select the software language.

- ▶ With the *Tools* menu you can carry out a PowerLaw analysis and thus represent the relationship of the average flow velocity to the waterway depth.
In this menu, you can also start the upgrade of the user firmware for the handheld unit (see Appendix C "Firmware upgrade").
- ▶ The *ADC* menu is used for transferring of measurement data from the handheld unit to the PC (see Chapter 9.3 "Transferring data to the PC").
- ▶ The *Export* menu offers an open interface for the export of data in various formats (.txt, XML, depth list), so that the data are also accessible to other evaluation programs, e.g. for BIBER, SoftwareQ or Excel.
- ▶ The *Help* menu provides information on the software used, e.g. the current version of OTT QReview.
Here you can also find the online operating instructions.

10 Maintenance work

The high-quality design of the OTT ADC makes only a little maintenance work necessary.

10.1 Handheld unit

- ▶ Ensure that the ports on the handheld unit are closed with the special protective covers when not in use.
- ▶ Check the charging state of the battery before and after the measurement and charge the battery if necessary.
- ▶ The battery only needs changing after being charged more than 500 times. Never replace the battery yourself! The replacement must be done at the factory by the OTT repair center (see Appendix E "Repair").
- ▶ Store the handheld unit in the transport case supplied when it is not in use. In this way it is protected from dust, damp and contamination.
- ▶ Wipe the handheld unit with a slightly damp, lint free cloth as necessary. Do not use wet cloths or aggressive solvents, cleaning materials or abrasives!

10.2 Sensor

- ▶ Before you pack the device after a measurement, remove any contamination and dry the sensor and rods with a dry, lint free and absorbent cloth.
- ▶ Regularly check the ultrasonic transducers for contamination, for example by sand. If necessary, clean the transducers with a lint free cloth or a soft brush.
- ▶ After using the sensor in sandy or muddy waterways, the sensor body should be cleaned under clear, running water. Ensure at the same time that the holes for the pressure cell chambers are washed out so that all contamination is removed. With heavy soiling, it is recommended that the sensor is first placed in clear water for a few minutes until all encrustation is dissolved.
- ▶ Store the sensor in the transport case supplied when it is not in use. In this way the device is protected from dust, damp and contamination.

11 Warnings and error messages

During a measurement, you may see warning messages or error messages on the display of the handheld unit. The messages and their meaning are listed below.

11.1 Warnings

- ▶ Stream width is incorrect. Check Edges.
The distance between near and far edges is too small. It must be at least 0.5 m.
→ Change the position of the near and far edges as appropriate.
(*Discharge Measuring /Settings/Discharge [1/3]/Near Edge or Far Edge*)
- ▶ This file already exists. Press [1] to overwrite.
The file name given already exists.
→ Press key 1 to overwrite the file (deletes the existing data) or allocate a new file name.
- ▶ Cannot calculate Nr of verticals. Spacing = 0
The user has given the value 0 for the distance between verticals. The OTT ADC cannot therefore calculate the overall number of verticals in the measurement cross-section.
→ Enter a spacing value > 0.
(*Discharge Measuring /Settings/Discharge [1/3]/Verticals/Spacing*)
- ▶ Position is beyond edge
The position of the verticals lies outside the area defined by the near and far edges.
→ Check the near and far edges and adjust the position of the verticals appropriately
(*Discharge Measuring /Settings/Discharge [1/3]/Verticals/Position*) or
(*Discharge/START/... /Vertical i/Position or Next vertical [i]/Position*)
- ▶ Depth cannot be zero. Please enter a valid depth.
At the start of the measurement of the first measure point of a new vertical, the water depth is automatically set to zero. The user is thus forced to give the water depth for each vertical.
→ Measure water depth
(*Discharge/START/Start Measuring/.../Point #i/Water Depth*)
- ▶ Not enough valid data
There are not enough valid measured values available to calculate the average flow velocity. Possible causes are an SNR value that is too low or water turbulence that is too high, each of which can lead to invalid measurements (see also Chapter 8.4 "Internal quality check").

11.2 Critical error messages

If a critical error message is displayed, a discharge measurement started cannot be finished.

▶ **FILE SYSTEM FAIL.** Press [1] to FORMAT

Can occur once after switching on a new handheld unit for the first time or a handheld unit with a new flash memory chip.

→ Press key 1 and format the flash memory.

▶ **Could not open/close/write to/delete the file**

Error in internal file system.

→ Format recorder.

(Advanced/Format recorder)

If the error reoccurs, there is a device error.

→ Send the handheld unit and sensor to the OTT repair center.

▶ **Error while starting sensor**

The CPU (Central Processing Unit) of the handheld unit could not make a connection to the digital signal processor at startup.

→ Send the handheld unit and sensor to the OTT repair center.

Please note

If a repair is necessary, please send both the handheld unit and sensor in the transport case to the OTT repair center irrespective of which system components are affected by the repair. The address of the OTT repair center can be found in Appendix E "Repair".

12 Troubleshooting

- ▶ The depth measured seems unrealistic.
 - ▶ Sensor properly calibrated in the air?
 - Calibrate the pressure cell as described in Chapter 6.2.1.
 - ▶ After switching on the handheld unit, startup process completed ("++++" symbols disappear in the display) before calibration function was called?
 - Only calibrate after the end of the startup process.
 - ▶ Sand or mud in pressure cell chamber?
 - Clean the chamber as described in Chapter 10.2.
 - ▶ Sensor correctly connected to the handheld unit?
 - Check the sensor connection cable. Check the number (12) and alignment of the contact pins in the connector (see Chapter 4.1).
- ▶ No velocities are displayed during measurement operation (-.-).
 - ▶ Continuous data output set?
 - Set the measured value display to *Continuous*.
(Main menu [2/2] /System Settings/System Menu/Display)
 - ▶ Ultrasonic transducers dirty?
 - Clean the ultrasonic transducers of any soiling (sand, mud, flotsam such as leaves or similar).
 - ▶ Sensor correctly connected to the handheld unit?
 - Check the sensor connection cable. Check the number (12) and alignment of the contact pins in the connector (see Chapter 4.1).
- ▶ The velocity measured seems unrealistic.
 - ▶ Ultrasonic transducers soiled or damaged?
 - Check the ultrasonic transducers for contamination (for example by sand) and for damage. If necessary, clean the transducer with an absorbent lint free cloth or a soft brush.
 - ▶ Sensor correctly aligned?
 - Align the sensor at right angles to the measurement cross-section (see Chapter 8.1). Ensure that the rod is held straight.
 - ▶ Obstruction in front of the sensor?
 - Remove the obstruction or select a different measuring position.
 - ▶ Data quality sufficient (SNR > 10, display symbol for data quality solid)?
 - Choose a different measuring position if necessary.
- ▶ The SNR value does not change or only little.
 - ▶ Sensor properly calibrated in the air?
 - Calibrate the pressure cell as described in Chapter 6.2.1.

13 Technical data

Velocity measurement

Measuring range	- 0.2 m/s to 2.4 m/s
Accuracy	± 1 % of the measured value ± 0.25 cm/s
Resolution	0.001 m/s
Measured volumes	
Distance from sensor	10 cm
Diameter	1 cm per sound pulse
Length	5 cm
Acoustic frequency ultrasonic transducer	6 MHz

Depth measurement

Piezoresistive pressure cell (absolute)	
Measuring range	0 to 5 m
Accuracy	0.1 % FS
Resolution	0.01 % FS
Max. overload	1.5 times the measuring range

Temperature measurement

Measuring range	- 5 °C to 35 °C
Accuracy	± 0.5 °C
Resolution	0.1 °C

Salinity

Range	0 ppt to 50 ppt (mg/l)
-------	------------------------

Power supply

Type	fixed battery pack, NiMH
Nominal voltage	9.6 VDC
Life	typically > 20 hours
Charging cycles	> 500
Output voltage of power supply	16 VDC

Operating conditions

Operating temperature range	- 20 °C to + 60 °C
Storage temperature range	- 40 °C to + 85 °C
Shock resistance	compatible with EN 60068-2-32

Dimensions and weight

Cylindrical sensor body	Ø 40 mm
Length	14.5 cm
Weight in air	800 g
Weight in water	620 g
Handheld unit	
Weight	700 g
Dimensions (L x W x H)	23.3 cm x 8.3 cm x 3.2 cm

Material

Sensor housing	Delrin® / stainless steel
Screws	stainless steel
Handheld unit	aluminium, powder coated
Keyboard	Autotex V 150 XI

IP protection class

Handheld unit	IP 65 housing, IP65 keyboard
Sensor	IP 68

EMC

EN 61000-6-2:2001
EN 61000-6-4:2001
FCC Part 15, subpart B, Section 145109
EMC Directive 89/336/EEC, Article 4
EMC Directive 2004/108/EU, Article 5

Internal data memory

Capacity

4 MB (flash)

Ultrasonic transducers

Frequency

6 MHz

Beam angle

20°

OTT QReview software

Operating system

Windows®98, Windows®ME,
Windows®NT, Windows®2000,
Windows®XP, Windows® Vista
Data transfer from handheld unit
Data check and processing
Data export (XML, ASCII)

Functionality

14 Order numbers and accessories

▶ OTT ADC – acoustic digital current meter	10.500.001.9.0
Versions available with version code	
– with 2.5 m connection cable and adapter for Ø 20 mm rods	1R
– with 6 m connection cable and adapter for Ø 20 mm rods	2R
– with 10 m connection cable and adapter for Ø 20 mm rods	3R
– with 2.5 m connection cable and adapter for rod type USGS	1H
– with 6 m connection cable and adapter for rod type USGS	2H
– with 10 m connection cable and adapter for rod type USGS	3H
▶ OTT ADC accessories	
Power supply with AC/DC converter	10.500.420.9.5
Universal power adapter set for power supply	97.850.022.9.5
Power cable for power supply	10.500.421.9.5
Charging cable	10.500.428.9.5
Adapter for 12 V (vehicle connection)	10.500.054.9.5
Universal attachment for handheld unit	10.500.057.9.5
USB connection cable for PC connection	10.500.422.9.5
Protective cover for sensor connection cable	10.500.423.9.5
Protective cover for handheld unit sensor socket	10.500.424.9.5
Protective cover for handheld unit USB socket	10.500.425.9.5
▶ Rod accessories	
Rod Ø 20 mm	
with base plate and point	
Division into dm	
– 2 m long, 2-part	16.000.126.9.2
– 3 m long, 3-part	16.000.128.9.2
– 4 m long, 4-part	16.000.129.9.2
– 5 m long, 5-part	16.000.130.9.2
– 6 m long, 6-part	16.000.131.9.2
Division into cm	
– 2 m long, 2-part	16.000.136.9.2
– 3 m long, 3-part	16.000.138.9.2
– 4 m long, 4-part	16.000.139.9.2
– 5 m long, 5-part	16.000.140.9.2
– 6 m long, 6-part	16.000.141.9.2

Extension pieces for Ø 20 mm rods

1 m long, division into dm

- 3-4 m	16.000.152.3.2
- 4-5 m	16.000.153.3.2
- 5-6 m	16.000.154.3.2
- 6-7 m	16.000.155.3.2

Extension pieces for Ø 20 mm rods

1 m long, division into cm

upon request

HERES top setting wading rod

Push on rod for Ø 20 mm rods

Allows the sensor to be vertically adjusted in the water.

The top setting wading rod is 1 m shorter than the respective rod in each case.

- 2 m long, 2-part	16.000.081.9.2
- 3 m long, 3-part	16.000.082.9.2
- 4 m long, 4-part	16.000.083.9.2
- 5 m long, 5-part	16.000.084.9.2

Direction indicator for rod

16.000.090.4.2

for showing the sensor direction when mounted without HERES top setting wading rod

Rod holder

16.000.007.2.1

with carrying strap

for a maximum of 6 rod lengths each of 1 m

or 5 HERES top setting wading rod pieces each 1 m long

Replacement pieces for HERES top setting wading rod

- starting piece, 1 m long	16.000.088.9.2
- middle piece, 1 m long	16.000.040.9.2
- end piece, 1 m long	16.000.038.9.2

Appendix A – Theory and practical suggestions for discharge measuring with the OTT ADC

The discharge in flowing waterways is defined as the water volume that flows through a particular cross-section in the time unit (DIN 4049 Part 1). It is normally given in m^3/s or l/s and is the product of the average cross-section velocity and the discharge cross-section flowed through.

Fig. 18: Example of a discharge cross-section for discharge measurement.

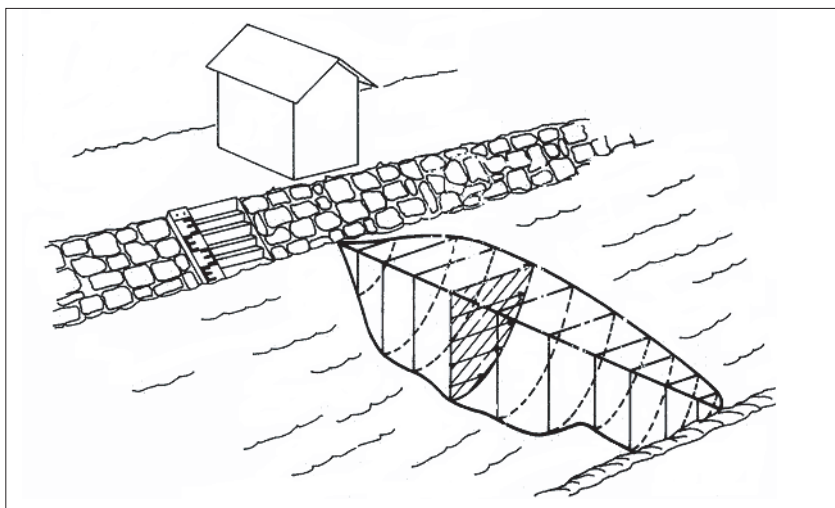

The discharge measurement with the classic verticals process is an indirect measuring method. The goal of the measurement is to determine the average flow velocity of the specified verticals and at the same time determine the discharge cross-section. In this way it is possible to calculate the discharge using a mathematical model at the end of the measurement (see Section A.2 "Overview: Methods of flow calculation").

A.1 Overview: Methods for velocity measurement

The average flow velocity at a vertical is calculated from a defined number of individual measurements at different depths. Applied to the vertical depth these individual velocities give an image of the velocity distribution (velocity surface, see also hatched surface in Figure 18). The quotient of velocity surface and water depth is the average flow velocity.

For the arrangement of individual points there are various methods. The following methods can generally be differentiated:

- ▶ Velocity distribution method (multi-point method)
- ▶ Method with reduced measure points
- ▶ Supplementary methods

The following table contains an overview of all methods for velocity measurement that are supported by the OTT ADC.

Tab. 3: Methods supported by the OTT ADC for velocity measurement

Method	Position of measure points	Formula for calculating the mean velocity	Comments
1-point measurement	0.6 x h	$V_m = V_{0.6}$	A
2-point measurement	0.2 / 0.8 x h	$V_m = (V_{0.2} + V_{0.8}) / 2$	A
3-point measurement	0.2 / 0.6 / 0.8 x h	$V_m = 0.25 \times (V_{0.2} + 2 \times V_{0.4} + V_{0.8})$	
4-point measurement	0.2 / 0.4 / 0.7 / 0.9 x h	$V_m = 0.25 \times (V_{0.2} + V_{0.4} + V_{0.7} + V_{0.9})$	
5-point measurement	near to surface / 0.2 / 0.6 / 0.8 x h / near to bed	$V_m = 0.1 \times (V_O + 3 \times V_{0.2} + 3 \times V_{0.6} + 2 \times V_{0.8} + V_S)$	B
6-point measurement	near to surface / 0.2 / 0.4 / 0.6 / 0.8 x h / near to bed	$V_m = 0.1 \times (V_O + 2 \times V_{0.2} + 2 \times V_{0.4} + 2 \times V_{0.6} + 2 \times V_{0.8} + V_S)$	B
2-point Kreps	near to surface / 0.62 x h	$V_m = 0.31 \times V_O + 0.634 \times V_{0.62}$	C
1-point ice measurement	0.5 x h _{effective}	$V_m = V_{0.5} \times K_{ice}$	$K_{ice} = 0.88 - 0.90$ (ISO 1996)
2-point ice measurement	0.2 / 0.8 x h _{effective}	$V_m = (V_{0.2} + V_{0.8}) / 2$	
Surface 1-point measurement	near to surface	$V_m = V_O \times K_O$	$K_O = 0.84 - 0.9$ (ISO 748)
Multi-point measurement	Number and position of the measure points are freely selected	See figure 19	D

A – Method with reduced measure points

Advantage: lower time requirement
 Disadvantage: based on the assumption of a consistent, logarithmic velocity distribution.

With new stations it is recommended to confirm the accuracy of the method with reduced measure points by using comparative measurements with the multi-point method.

B – Supplementary methods

Supplementary methods with which the velocity near the surface V_0 and the velocity near the bed V_s are measured require that the sensor is positioned as near as possible to the water surface and the waterway bed. Near the water surface the sensor must be completely submerged. The position of the highest and lowest measure points should be the same for each vertical as far as possible. It should be ensured that a measurement immediately below the surface is not influenced by wind and random surface waves.

C – 2-point KREPS measurement

Approximation method from the year 1949 where the velocity near the surface and at 38% of the depth are measured. It is named after its developer, Oberbau- rat (government building officer) Dr. techn. Harald Kreps (Austrian hydrologist). The notes under A apply.

D – Multi-point method

With this method, the measure points are allocated freely based on the water depth and flow conditions. It is also here important that the highest and lowest measure points are positioned as near to the water surface/bottom as possible. The following table gives a rough guide to the number of measure points.

Tab. 4: Number of measure points in relation to the waterway depth

Water depth in m	Number of measure points
<1	3-4
1-3	4-6
4-7	5-8
>7	6-10

Advantage: Exact recording of the velocity surfaces

Disadvantage: Decreasing measurement reliability with varying water levels.

The average flow velocity is calculated according to the following rule:

Fig. 19: Calculation of the average flow velocity

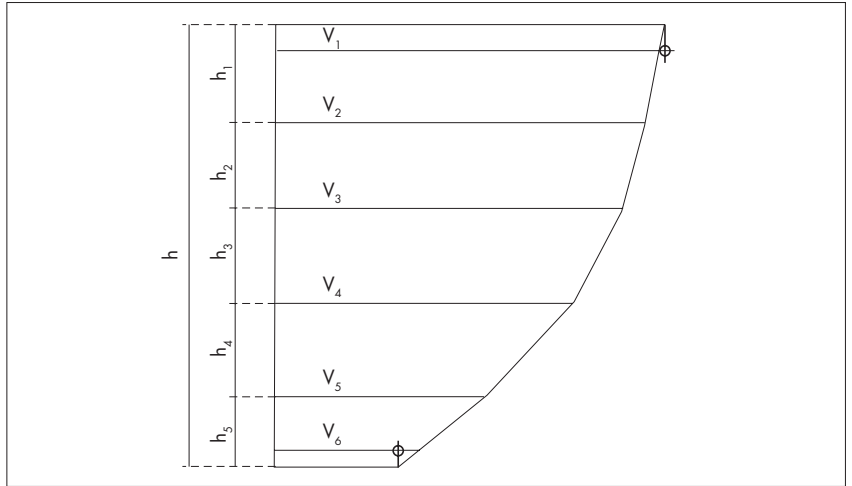

$$V_m = \frac{(V_1 + V_2) \times h_1 + (V_2 + V_3) \times h_2 + \dots + (V_{n-1} + V_n) \times h_{n-1}}{2h}$$

A.2 Overview: Methods of discharge calculation

The calculation of the discharge can be done with either graphical or arithmetic methods. The graphical methods require large amounts of processing power, and are therefore supported by conventional evaluation programs for discharge volumes (e.g. SoftwareQ/BIBER).

The OTT ADC supports the arithmetic calculation method according to EN ISO 748.

MEAN section method (procedure with average cross-section)

With this method, the measurement cross-section is divided into individual flow segments. Each partial segment is limited by two adjacent verticals.

Fig. 20: MEAN section method

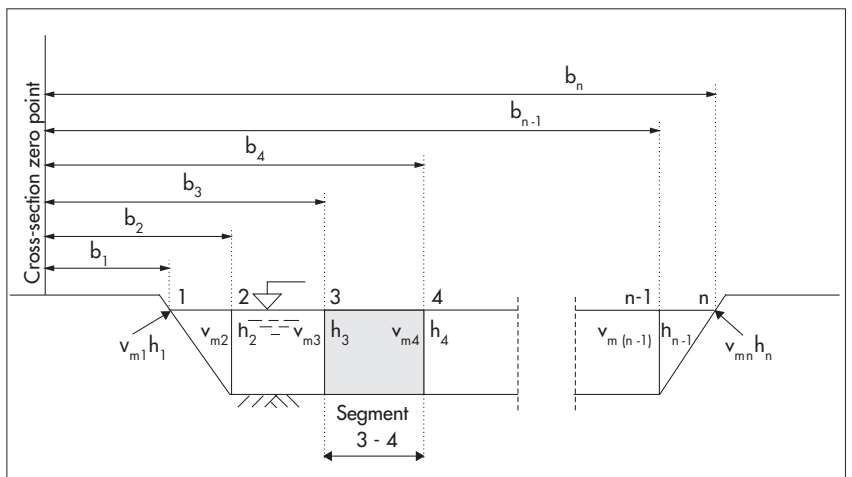

$$q_{3-4} = \left(\frac{V_{m3} + V_{m4}}{2} \right) \times \left(\frac{h_3 + h_4}{2} \right) \times (b_4 - b_3)$$

The equation given describes the discharge calculation for an individual segment for the MEAN section method. The total discharge is thus the sum of the partial discharges of all segments.

Comment

The additional discharge element of the two edge segments is calculated with the assumption that speed and depth at the edges are zero.

MID section method (mid cross-section method)

With the mid cross-section method, the measurement cross-section is also divided into individual segments. The individual segments do not, however, lie between the verticals, but are defined by half the distance to the neighboring vertical in each case. For this reason, the first and last verticals should be as near to the edges as possible when using this method.

Fig. 21: MID section method

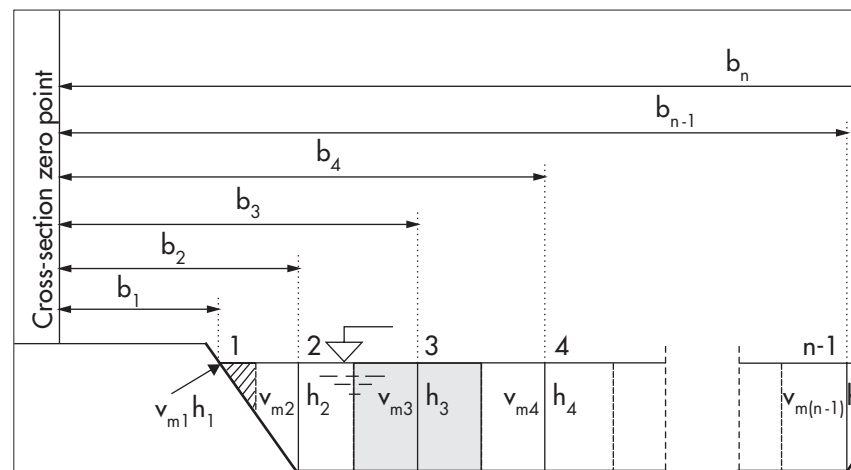

$$q_3 = v_{m3} \times \left(\frac{(b_3 - b_2) + (b_4 - b_3)}{2} \right) \times h_3$$

The equation given describes the discharge calculation for an individual segment for the MID section method. The total discharge is thus the sum of the partial discharges of all segments.

Comment

In practice, experience shows that this method leads to more exact results compared to the average cross-section method and is also quicker to calculate. It is therefore the default setting for the handheld unit of the OTT ADC.

Taking account of vertical edges

Both previously described methods take account of the flow element in the edge areas with vertical edge walls using the following method (Fig. 22).

Fig. 22: Taking account of vertical edges in the discharge calculation

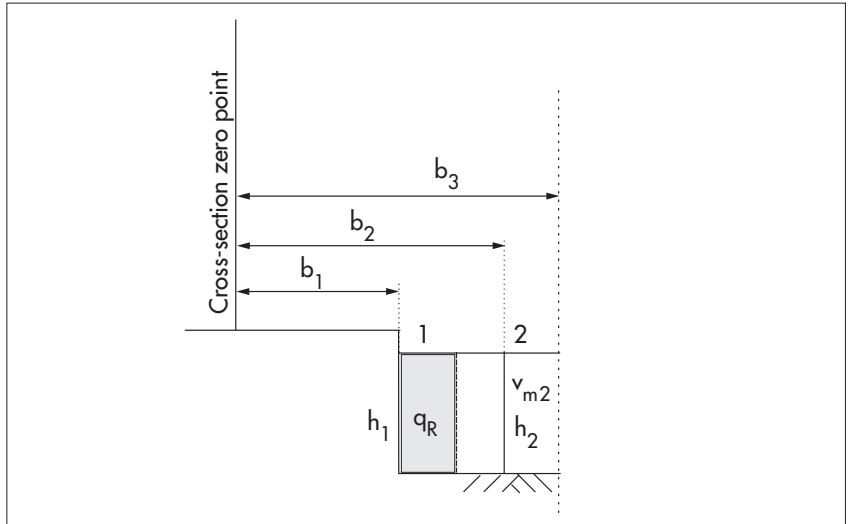

$$q_R = \left(h_1 \times \frac{(b_2 - b_1)}{2} \times K_R \times V_{m2} \right)$$

K_R : edge factor for allowing for the roughness of the edge wall

The edge factor K_R is dependent on the roughness of the edge. The K_R values shown in the following table can be considered as guide values.

Tab. 5: Edge factor K_R dependent on the roughness of the edge

Edge characteristics	K_R
Smooth edge with no vegetation (e.g. concrete, steel, cement)	0.8 – 0.9
Brick sides with vegetation	0.7
Rough walls with heavy vegetation	0.6 – 0.5

Appendix B – Flow velocity measurement with the OTT ADC (functional principle)

For the measurement of the flow velocity, the OTT ADC is aligned towards the flow.

As the sensor body influences the incoming flow dependent on the flow velocity, the velocity measurement is a two-stage process:

- ▶ 1. Rough velocity measurement by a cell near the sensor
- ▶ 2. Exact velocity measurement in measured volumes (approx. 10 cm in front of the sensor)

The measurement of the flow velocity is based on the evaluation of the phase difference from independent pulse echos.

For this purpose, the ultrasonic transducers of the OTT ADC sensor transmit in each case two short ultrasound impulses with a modulation frequency of 6 MHz. Afterwards the sensor receives the reflections caused by particles in the water. The signal received is amplified, filtered and digitalized. With the information attained, the phase shift of the two signals is calculated and converted into the proportional velocity.

The current measured value is an average of the individually transmitted sound impulses per sound pulse, which are transmitted in a burst lasting 75 ms. From this the measured values each second for velocity, SNR and correlation are generated. Each measured value is subject to an internal quality check (see Chapter 8).

Appendix C – Firmware upgrade

The firmware relevant to the user is a program integrated into the handheld unit that is responsible among other things for the representation of menus, sub menus and subsequent windows. Every handheld unit is supplied with a particular version of the user firmware.

The version can be queried via the main menu [2/2].

See menu

System Status/System Info

Example of output: *1.03 / 117*

The last three numbers (in the example *117*) constitute the version number, which is part of the firmware file name.

An upgrade of the firmware is only necessary if OTT MESSTECHNIK releases a new firmware version, for example if new functions have been included.

Information on any releases can be found on the Internet at

www.ott.com. Here you can find the current firmware.

- ▶ Firmware file name: *ADC_Vxxx.bin*.
 xxx: Version number
 The file name must not be changed!

Carry out the upgrade

The processing program OTT QReview is available to carry out the upgrade of the user firmware. The upgrade is carried out in two steps:

1. Put the handheld unit into upgrade mode
2. Carry out the upgrade

Requirements:

- ▶ The batteries of the handheld unit are charged (battery symbol in display is completely filled)
- ▶ The OTT QReview (*QReview.exe*) software is installed on the PC
- ▶ USB driver of the handheld unit is installed on the PC
- ▶ The current firmware is saved on the PC.

Please note

The batteries of the handheld unit must be fully charged for the upgrade process! With insufficient power supply the upgrade process cannot be carried out.

1. How to put the handheld unit into upgrade mode

- Switch off the device.
- Connect the handheld unit to the PC via the USB connection.
- Put the handheld unit into upgrade mode:
Press key combination "." and "-", hold and switch on the handheld unit.
The message *FIRMWARE UPGRADE CHECKING STATUS* appears on the display. After a few seconds the *UPGRADE CODE* is requested.
- Enter the upgrade code:
Enter the numbers 1, 2, 3 and 4 and confirm (press ■ key).

The handheld unit is now in firmware upgrade mode and ready for the upgrade.

2. How to carry out the upgrade

- Start OTT QReview.
- In the *Tools* menu select the *ADC Firmware Upgrade* menu point.
- Select the current firmware in the subsequent window under *Upgrade file* and confirm with the *Open* button.
- Select the COM port *Serial Port* that is used by the USB interface that the handheld unit is connected to (see Chapter 9.2.1, Section "Checking the COM port").
- Press the *Start* button.

The upgrade is carried out. In the *Status* area of the *ADC Firmware Upgrade* window you can see information on the progress of the upgrade. As soon as the upgrade is complete, a suitable message is displayed. The handheld unit is automatically switched off and put back into ready mode.

Please note

During the upgrade process the handheld unit must not be switched off. The on/off switch of the handheld unit is therefore deactivated during the upgrade process.

Appendix D – Standard settings

Settings on the handheld unit

Volume	10
Contrast	8
Background illumination	Automatic
Units	Metric
Language	English
Measured value display (velocity)	Continuous
Hours:Minutes:Seconds*	00:00:00
Year:Month:Day*	01/01/00

Standard settings for parameters for discharge measuring

Stream width	10.00 m
Near edge position	0.00 m
Far edge position	10.00 m
Position of first vertical	1.00 m
Spacing of verticals	1.00 m
Measure Order	alternating
Sensor offset	0.00 m
Point offset	0.00 m
Roughness	0,70
Correction factor (ice, 1-point measurement)	0,89
Correction factor (ISO, surface measurement)	0,80
Depth	0.00 m
Measurement duration (averaging time)	30 s
Salinity	0 ppt

System constants

Interval for calibrating the depth measurement	30 min
Automatic background illumination (length of inactivity until switching off)	30 s
Permitted number of failed measurements within a discharge measurement	max. 10
Permitted change in velocity between two measurements	max. 0.25 m/s
Minimum spacing of the measure points of a vertical with multi-point measuring	0.10 m
Minimum sensor depth	0.02 m
Required correlation value	40% – 100%
Required SNR value	≥ 10 db
Distance of vertical to edge	min. 0.02 m
Number of verticals	1 – 100
Number of measure points per vertical	1 – 10

* The values for date and time are carried forward and therefore deviate from the the basic settings when delivered.

Appendix E – Repair

- With a device defect, use Chapter 12 "Troubleshooting" to see if you can resolve the problem yourself.
- In case of device defects, please contact the repair center of OTT MESSTECHNIK:

OTT MESSTECHNIK GmbH & Co. KG
Repaircenter
Ludwigstraße 16
87437 Kempten · Germany
Telephone +49 (0)831/5617-433
Fax +49 (0)831/5617-439
repair@ott.com

Please note

Send both the handheld unit and the sensor to the OTT Repaircenter in the transport case provided irrespective of which component appears to be affected by the fault.

Warning: Only have a defective OTT ADC checked and repaired by the repair center at OTT MESSTECHNIK. Never make any repairs yourself under any circumstances. Any repairs or attempted repairs carried out by the customer will result in the loss of any guarantee rights.

Appendix F – Note on the disposal of old units

Within the member countries of the European Union



In accordance with the European Union guideline 2002/96/EC, OTT MESSTECHNIK takes back old devices within the member countries of the European Union and disposes of them in an appropriate way. The devices concerned by this are marked with the symbol shown aside.

- For further information on the return procedure, please contact your local sales contact. You will find the address of the sales partners in the internet on "www.ott.com". Please take into consideration also the national implementation of the EU guideline 2002/96/EC of your country.

For all other countries

- Dispose of the OTT ADC properly after taking out of service.
- Observe the regulations valid in your country for the disposal of electronic devices.
- Never put the OTT ADC into the normal household waste.

Materials used

See Chapter 13 "Technical data".



**Konformitätserklärung
Declaration of Conformity
Declaration de Conformité**

Wir/ We/ Nous OTT Messtechnik GmbH & Co. KG
Anschrif/ Address/ Adresse Ludwigstraße 16
D-87437 Kempten

erklären, daß das Produkt/ declare, that the product/ déclarons, que le produit

Bezeichnung/ Name/ Nom **OTT ADC**

Artikel- Nr./ Article No./ No. d' Article **10.500.001.9.0XX, 10.500.002.9.0XX**

mit den Anforderungen der Normen/ fulfills the requirements of the standard/ satisfait aux exigences des normes

EG (2004/108/EG)

Störaussendung/ emission/ émission

national: EN 61000-6-4 Klasse/ class/ classe A	international: IEC 61000-6-4 class/ classe A
--	--

FCC Part 15

Störfestigkeit/ noise immunity/ immunité

national: EN 61000-6-2 EN 61000-4-2 EN 61000-4-3	international: IEC 61000-6-2 IEC 61000-4-2 IEC 61000-4-3
---	---

und den hinterlegten Prüfberichten übereinstimmt und damit den Bestimmungen entspricht/
and the taken test reports and therefore corresponds to the regulations of the Directive/
et les rapports d'essais notifiés et, ainsi, correspond aux réglement de la Directive.

Ort und Datum der Ausstellung/ Kempten, den 2007-11-04
Place and Date of Issue/
Lieu et date d' établissement

Name und Unterschrift des Befugten/ i.v. Peter Fend
Name and Signature of authorized person/
Nom et signature de la personne autorisée
Peter Fend
(Director R&D)

OTT MESSTECHNIK GmbH & Co. KG
Postfach 21 40 · 87411 Kempten
Ludwigstraße 16 · 87437 Kempten
Tel.: +49(0)831 / 5617-0
Fax: +49(0)831 / 5617-209
info@ott.com
www.ott.com

Geschäftsführer: Dr.-Ing. Anton Felder · Persönlich haftende Gesellschafterin: **OTT MESSTECHNIK Verwaltungs GmbH**
Sitz der Ges.: Kempten · Registergericht Kempten HRB 7687 und HRA 3807 · USt.-ID.-Nr. DE 128780710 · Steuer-Nr. 127/171/51206
WEEE-Registrierungs-Nummer: 49590817

Deutsche Bank AG München · BLZ 700 700 10 · Kto.Nr. 409 0304 00 · BIC: DEUTDE33 · IBAN: DE96 7007 0010 0409 0304 00

Es gelten unsere Allgemeinen Geschäftsbedingungen (siehe „www.ott.com/AGB“)
All business transactions shall be subject to our General Terms and Conditions (see "www.ott.com/GTC")

Appendix H - Overview main menu

H.1 Main menu part 1

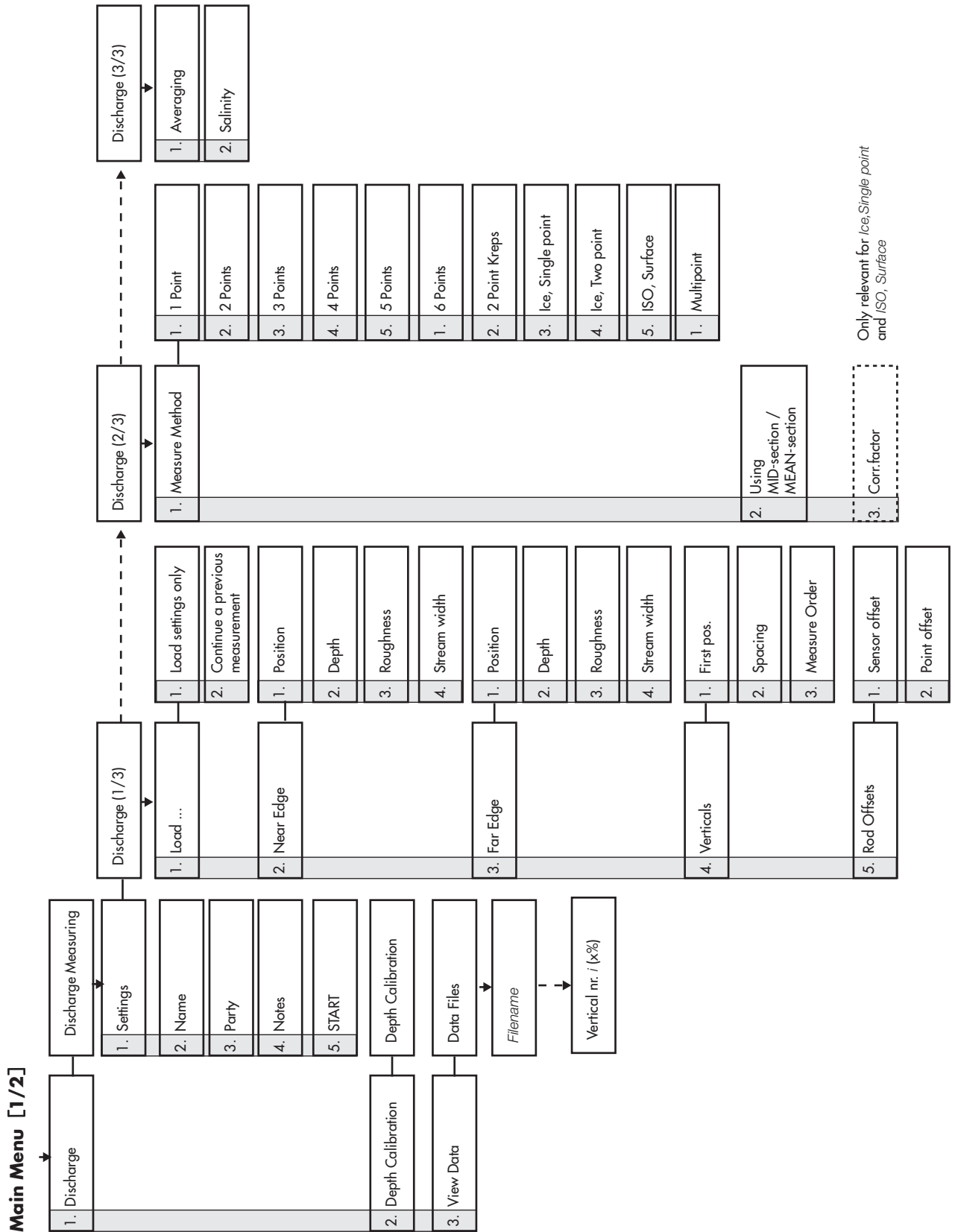

H.2 Main menu part 2

Main Menu [2/2]

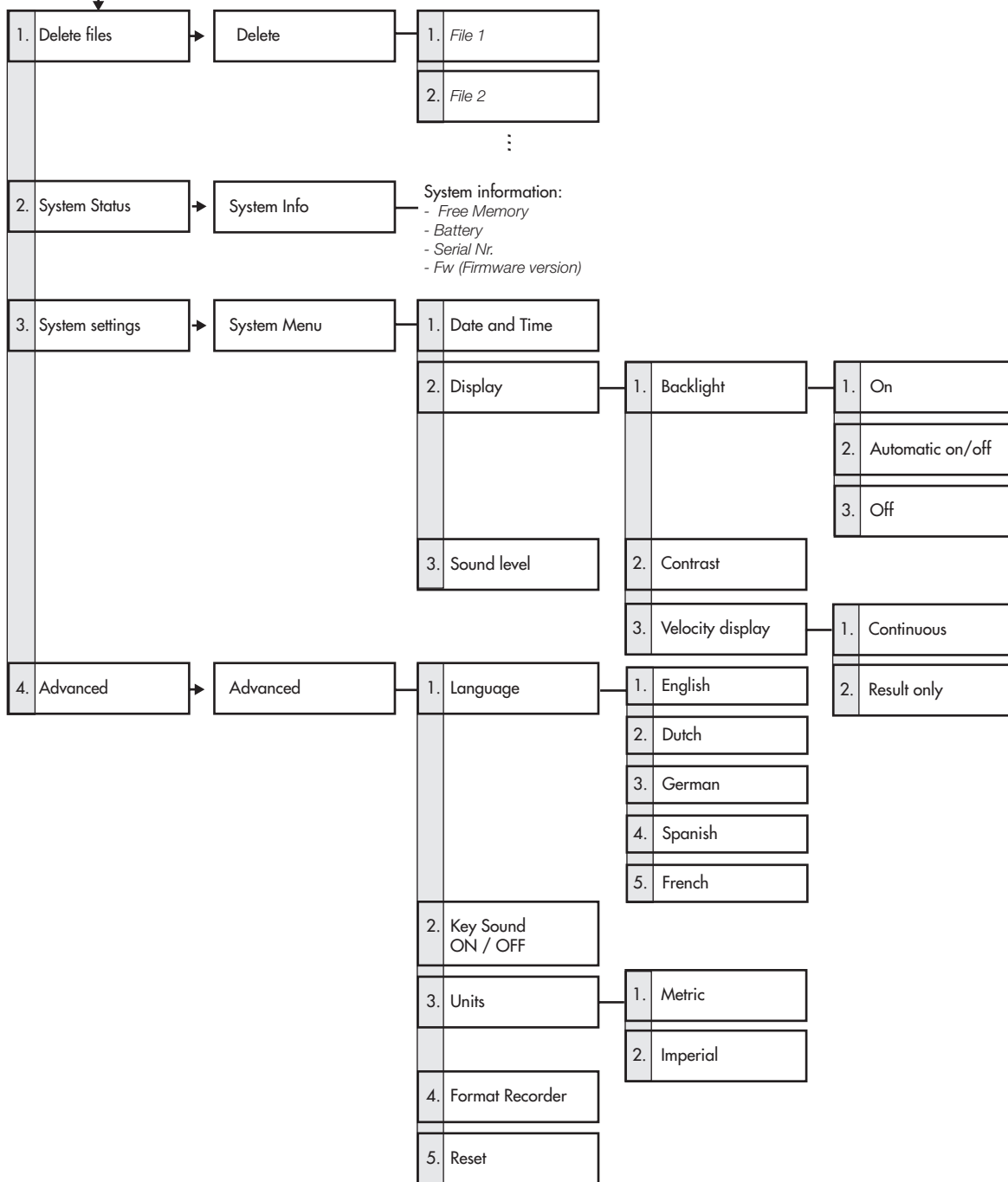

Document number
10.500.001.B.E 01-0108

OTT MESSTECHNIK GmbH & Co. KG

Ludwigstrasse 16
87437 Kempten · Germany
Tel. +49 (0)831 5617-0
Fax +49 (0)831 5617-209

info@ott.com
www.ott.com